

(12) STANDARD PATENT
(19) AUSTRALIAN PATENT OFFICE

(11) Application No. **AU 2006232995 B2**

(54) Title
Guided kinetic penetrator

(51) International Patent Classification(s)
F41G 7/00 (2006.01) **F42B 14/06** (2006.01)
F42B 10/00 (2006.01) **G08C 19/06** (2006.01)
F42B 14/00 (2006.01)

(21) Application No: **2006232995** (22) Date of Filing: **2006.03.14**

(87) WIPO No: **WO06/107530**

(30) Priority Data

(31) Number (32) Date (33) Country
11/100,243 **2005.04.05** **US**

(43) Publication Date: **2006.10.12**

(44) Accepted Journal Date: **2010.05.27**

(71) Applicant(s)
Raytheon Company

(72) Inventor(s)
Schneider, Arthur

(74) Agent / Attorney
Griffith Hack, Level 3 509 St Kilda Road, Melbourne, VIC, 3004

(56) Related Art
US 4730561 A
US 5054712 A
US 6237496 B1
US 4579298 A
US 4708304 A

(19) World Intellectual Property Organization
International Bureau



(43) International Publication Date
12 October 2006 (12.10.2006)

PCT

(10) International Publication Number
WO 2006/107530 A2

- (51) International Patent Classification:
F42B 10/00 (2006.01)
- (21) International Application Number:
PCT/US2006/009105
- (22) International Filing Date: 14 March 2006 (14.03.2006)
- (25) Filing Language: English
- (26) Publication Language: English
- (30) Priority Data:
11/100,243 5 April 2005 (05.04.2005) US
- (71) Applicant (for all designated States except US):
RAYTHEON COMPANY [US/US]; BUILDING
807/MS F8, P.O. Box 11337, Tucson, Arizona 85734-1337
(US).
- (72) Inventor; and
- (75) Inventor/Applicant (for US only): **SCHNEIDER,
Arthur** [US/US]; 999 S. Suncove Drive, Tucson, Arizona
85748 (US).
- (74) Agent: **GIMORE, Douglas**; NOBLITT & GILMORE,
LLC, SUITE 6000, 4800 North Scottsdale Road, Scottsdale,
Arizona 85251-7630 (US).

- (81) Designated States (unless otherwise indicated, for every kind of national protection available): AE, AG, AL, AM, AT, AU, AZ, BA, BB, BG, BR, BW, BY, BZ, CA, CH, CN, CO, CR, CU, CZ, DE, DK, DM, DZ, EC, EE, EG, ES, FI, GB, GD, GE, GH, GM, HR, HU, ID, IL, IN, IS, JP, KE, KG, KM, KN, KP, KR, KZ, LC, LK, LR, LS, LT, LU, LV, LY, MA, MD, MG, MK, MN, MW, MX, MZ, NA, NG, NI, NO, NZ, OM, PG, PH, PL, PT, RO, RU, SC, SD, SE, SG, SK, SL, SM, SY, TJ, TM, TN, TR, TT, TZ, UA, UG, US, UZ, VC, VN, YU, ZA, ZM, ZW.
- (84) Designated States (unless otherwise indicated, for every kind of regional protection available): ARIPO (BW, GH, GM, KE, LS, MW, MZ, NA, SD, SL, SZ, TZ, UG, ZM, ZW), Eurasian (AM, AZ, BY, KG, KZ, MD, RU, TJ, TM), European (AT, BE, BG, CH, CY, CZ, DE, DK, EE, ES, FI, FR, GB, GR, HU, IE, IS, IT, LT, LU, LV, MC, NL, PL, PT, RO, SE, SI, SK, TR), OAPI (BF, BJ, CF, CG, CI, CM, GA, GN, GQ, GW, ML, MR, NE, SN, TD, TG).

Published:
— without international search report and to be republished upon receipt of that report

For two-letter codes and other abbreviations, refer to the "Guidance Notes on Codes and Abbreviations" appearing at the beginning of each regular issue of the PCT Gazette.

(54) Title: GUIDED KINETIC PENETRATOR

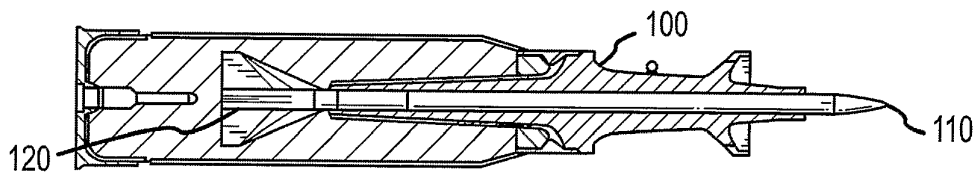

(57) Abstract: The disclosed system, device and method for guiding a hypersonic kinetic penetrator projectile (300) generally includes a kinetic penetrator body (110, 230) and a slip-over electronic guidance unit (120, 220), where the kinetic penetrator body slidably mounts through the slip-over electronic guidance unit. Disclosed features and specifications may be variously controlled, adapted or otherwise optionally modified to improve accuracy and control of a hypersonic projectile. Exemplary embodiments of the present invention generally provide multi-use slip-over electronic guidance units for hypersonic kinetic penetrator projectiles in 105 mm and 120 mm munition rounds, surface-to-surface missiles, and air-to-surface missiles.

WO 2006/107530 A2



***IN THE UNITED STATES PATENT AND TRADEMARK OFFICE
AS RECEIVING OFFICE FOR THE
PATENT COOPERATION TREATY***

Patent Application for:

GUIDED KINETIC PENETRATOR

Inventors: Arthur Schneider (Tucson, AZ, USA)

FIELD OF INVENTION

[0001] The present invention generally concerns kinetic energy projectiles; and more particularly, representative and exemplary embodiments of the present invention generally relate to multi-use electronic guidance units for rockets and munitions.

BACKGROUND OF INVENTION

[0002] It has been demonstrated that a hardened long-rod penetrator delivering in excess of 5 megajoules of energy at hypersonic velocity to the armor of a tank can penetrate the armor and destroy the tank. This generally involves boosting the rod to hypersonic velocity using a gun-launched munition or a rocket motor.

[0003] Increased deployment of gun-launched and rocket-launched ordinance has resulted in their application to a wider variety of targets, which in turn has resulted in the production of different types of munitions and rockets adapted to carry kinetic penetrator rods. The different types of munitions and rockets

required to defeat a variety of targets generally increases the need for producing and maintaining a large inventory of munitions and missiles.

5 [0004] Because they are unguided, gun-launched munitions that include kinetic penetrator rods are generally effective at relatively short ranges. Accurate guidance may extend the effective range of these gun-launched munitions. Rocket-launched missiles, such as direct fire missiles, may include kinetic penetrator rods and have a
10 range in excess of gun-launched munitions.

[0005] Measurement of roll angle is generally required for projectile guidance in either gun-launched or rocket-launched ordinance; however, launch acceleration forces experienced by the projectile may damage conventional
15 inertial measurement guidance systems. Various methods of measuring roll angle using solid-state electronics capable of withstanding launch acceleration have been previously demonstrated.

[0006] A guidance system for use in both gun-launched
20 munitions and rocket-launched missiles suitably configured to deliver kinetic energy projectiles would be desirable. This would result in greater mission flexibility and reduced inventory for guided kinetic penetrator projectiles.

25

SUMMARY OF THE INVENTION

[0007] In various representative aspects, the present disclosure provides a system, device and method for guiding a hypersonic kinetic energy projectile. Exemplary
30 features generally include a kinetic penetrator body and a slipover electronic guidance unit, where the penetrator body slidably engages the slip-over electronic guidance unit.

[0008] Advantages of the present invention will be set
35 forth in the Detailed Description which follows and may be apparent from the Detailed Description or may be learned by practice of exemplary embodiments of the invention.

Still other advantages of the invention may be realized by means of any of the instrumentalities, methods or combinations particularly pointed out in the Claims.

[0008a] In one aspect, the present disclosure provides a
5 projectile guidance system comprising:
a detachable launch system defining an inner volume;
a kinetic penetrator body at least partially enclosed
within the inner volume of the detachable launch system;
and
10 a slip-over guidance unit approximately forming an open
ended cylinder, wherein:
the slip-over guidance unit is enclosed within the inner
volume of the detachable launch system; and
the kinetic penetrator body longitudinally slidably mounts
15 to the slip over guidance unit through the open-ended
cylinder, wherein an exterior surface portion of the
kinetic energy penetrator body engages an inner surface of
the open-ended cylinder before the projectile is launched.

[0008b] In another aspect, the present disclosure provides
20 a kinetic energy projectile device, comprising:
a detachable exterior shell;
a slip-over electronic guidance unit forming an open-ended
cylinder with an exposed inner surface, wherein the slip-
over electronic guidance unit is enclosed within the
25 detachable exterior shell;
a kinetic penetrator body disposed at least partially
within the detachable exterior shell, wherein:
the kinetic penetrator body longitudinally slidably mounts
to the slip-over electronic guidance unit through the
30 inner surface of the slip-over electronic guidance unit
prior to the kinetic energy projectile device launching;
and
the slip-over electronic guidance unit engages with the
kinetic penetrator body via at least one of a locking
35 taper and a flare; and
at least one of a divert charge disposed on the slip-over
electronic guidance unit and a substantially moveable nose

disposed on the kinetic penetrator body, wherein the moveable nose is configured to pivot relative to the kinetic penetrator body.

5 [0008c] In another aspect, the present disclosure provides a method for command guiding a hypersonic projectile, said method comprising steps of:

providing a detachable launch system defining an inner volume;

10 providing a kinetic penetrator at least partially enclosed within the inner volume of the detachable launch system;

providing a slip-over electronic guidance unit approximately forming an open-ended cylinder, wherein: the slip-over guidance unit is enclosed within the inner volume of the detachable launch system; and

15 the kinetic penetrator body is suitably configured to longitudinally slidably mount to the slip-over electronic guidance unit through an open-ended cylinder, wherein an exterior surface portion of the kinetic energy penetrator body engages an inner surface of the open-ended cylinder
20 before the projectile is launched; and
at least one of:

providing at least one of a divert charge disposed on the slip-over electronic guidance unit and a substantially moveable nose disposed on the kinetic penetrator body; and
25 providing at least one divert charge disposed on the penetrator body.

BRIEF DESCRIPTION OF THE DRAWINGS

30 [0009] Representative elements, operational features, applications and/or advantages of the present invention reside inter alia in the details of construction and operation as more fully hereafter depicted, described and claimed - reference being made to the accompanying drawings forming a part hereof, wherein like numerals
35 refer to like parts throughout. Other elements, operational features, applications and/or advantages will become apparent in light of certain exemplary embodiments

recited in the Detailed Description, wherein:

[0010] FIG. 1 representatively illustrates a side cross-sectional view of a munition round in accordance with an exemplary embodiment of the present invention;

5 [0011] FIG. 2 representatively illustrates a side cross-sectional view of a rocket motor assembly having a kinetic penetrator body in accordance with an exemplary embodiment of the present invention;

10 [0012] FIG. 3 representatively illustrates a side cross-sectional view of a hypersonic kinetic penetrator projectile in accordance with an exemplary embodiment of the present invention; and

[0013] FIG. 4 representatively illustrates a lateral cross-sectional view of a hypersonic kinetic penetrator projectile in accordance with an exemplary embodiment of the present invention.

[0014] Elements in the Figures are illustrated for simplicity and clarity and have not necessarily been drawn to scale. For example, the dimensions of some of the elements in the Figures may be exaggerated relative to other elements to help improve understanding of various embodiments of the present invention. Furthermore, the terms “first”, “second”, and the like herein, if any, are used *inter alia* for distinguishing between similar elements and not necessarily for describing a sequential or chronological order. Moreover, the terms “front”, “back”, “top”, “bottom”, “over”, “under”, and the like in the Description and/or in the Claims, if any, are generally employed for descriptive purposes and not necessarily for comprehensively describing exclusive relative position. Any of the preceding terms so used may be interchanged under appropriate circumstances such that various embodiments of the invention described herein may be capable of operation in other configurations and/or orientations than those explicitly illustrated or otherwise described.

DETAILED DESCRIPTION OF EXEMPLARY EMBODIMENTS

[0015] The following representative descriptions of the present invention generally relate to exemplary embodiments and the inventor's conception of the best mode, and are not intended to limit the applicability or configuration of the invention in any way. Rather, the following description is intended to provide convenient illustrations for implementing various embodiments of the

invention. As will become apparent, changes may be made in the function and/or arrangement of any of the elements described in the disclosed exemplary embodiments without departing from the spirit and scope of the invention.

[0016] Various representative implementations of the present invention may be applied to any system for a kinetic energy projectile guidance system. Certain representative implementations may include, for example: gun-launched munitions having a kinetic energy projectile; rocket-launched missiles having a kinetic energy projectile; and/or the like. A detailed description of an exemplary application, namely a kinetic energy projectile guidance system, is provided as a specific enabling disclosure that may be generalized to any application of the disclosed system, device and method for projectile guidance in accordance with various embodiments of the present invention.

[0017] Fig. 1 representatively illustrates a side cross-sectional view of a munition round **100** in accordance with an exemplary embodiment of the present invention. Munition round **100** may be configured for deployment from a gun, such as a cannon, and may comprise, for example a sabot munition round. Munition round **100** may also include kinetic penetrator body **110** and slip-over electronic guidance unit **120** both housed substantially within munition round **100**. In an exemplary munitions embodiment, such as a sabot round, kinetic penetrator body **110** may be generally smaller than the bore of the gun firing the munition round. The sabot shroud generally fits around the kinetic penetrator body **110**, allowing it to be safely fired from the gun.

Engagement of the slip-over electronic guidance unit **120** to the kinetic penetrator body **110** may be accelerated during propellant burn of the munition **100**. After firing, the sabot generally falls away leaving the kinetic penetrator body **110** (with the slip-over electronic guidance unit **120** slidably engaged) continuing on toward the target. The relatively small diameter of the penetrator body **110** concentrates kinetic energy on a relatively small portion of the target, thereby increasing the probability of penetrating the target.

[0018] In an exemplary embodiment, kinetic penetrator body **110** may include a substantially cylindrical rod-like structure comprising a hardened material comprising, for example: tungsten; carbide steel; depleted uranium; and/or the like. Alternatively, conjunctively, or sequentially, one end of kinetic penetrator **110** may be aerodynamically shaped to provide a high ballistic coefficient. In another exemplary embodiment in accordance with the present invention, slip-over guidance unit **120** may include a substantially hollow cylindrical finned structure suitably adapted to receive kinetic penetrator body **110** as described in greater detail *vide infra*.

[0019] Fig. 2 representatively illustrates a side cross-sectional view of a rocket motor assembly **200** having a kinetic penetrator body **230** in accordance with an exemplary embodiment of the present invention. One example utilizes a diameter substantially compatible with the TOW missile so that it may be launched from existing TOW missile launchers. Rocket motor assembly **200** may be included in a missile, such as a surface-to-surface or air-to surface cruise missile, and/or the like. Rocket motor assembly **200** may include a

forward payload section and an aft section. Aft section may comprise components that are conventional utilized for a rocket motor assembly **200** such as, for example, jet engines, fuel, rocket motors, guidance and communications equipment, aerodynamic stabilization or control surfaces (e.g., such as fins or canards), and/or the like. Aft section may also include a penetrator body storage cavity **210** for storing kinetic penetrator body **230** for transportation.

[0020] Forward payload section may include, for example, payload items such as munitions, fuel and the like. In another representative embodiment, forward payload section may further include slip-over electronic guidance unit **220**. In yet another exemplary embodiment, slip-over guidance unit **220** may include a substantially hollow cylindrical finned structure suitably adapted to receive kinetic penetrator body **230**. The nose portion of forward payload section may include slots **240** to accommodate fins of slip-over electronic guidance unit **220**.

[0021] In still another exemplary embodiment, slip-over electronic guidance unit **220** may be stored in forward payload section of rocket motor assembly **200** during transit. Prior to launch, kinetic penetrator body **230** may be moved forward, through slip-over electronic guidance unit **220** to engage with slip-over electronic guidance unit **220**. In such a configuration, kinetic penetrator body **230** and slip-over electronic guidance unit **220** may be disposed in a manner similar to that shown and described in Fig.1 with reference to munition round **100**. The rocket motor assembly **200** may be boosted to a hypersonic velocity and thereafter burned out. Engagement of slip-over

guidance unit **220** may be tightened during propellant burn of the rocket motor assembly **200**. The nose portion of the forward payload section may be configured to permit kinetic penetrator body **230** and slip-over electronic guidance unit **220** (together comprising a hypersonic kinetic penetrator projectile) to separate, be command guided and strike the target with hypersonic velocity.

[0022] Fig. **3** representatively illustrates a side cross-sectional view of a hypersonic kinetic penetrator projectile **300** in accordance with an exemplary embodiment of the present invention. Hypersonic kinetic penetrator projectile **300** may include kinetic penetrator body and slip-over guidance unit as shown and generally described with reference to Fig.'s **1** and **2**. Slip-over guidance unit may be a substantially hollow cylindrical finned structure suitably adapted to receive kinetic penetrator body.

[0023] Kinetic penetrator body may slide forward through slip-over electronic guidance unit and engage *via* locking taper **330**. Slip-over electronic guidance unit may have an inner diameter suitably adapted for slidable engagement over the front portion of kinetic penetrator body. In a representative and exemplary application, the penetrator body generally slides 'nose first' through slip-over guidance unit during factory assembly of a gun cartridge or just prior to firing a rocket boosted rod.

[0024] In another embodiment of the present invention, locking taper **330** may comprise a rear portion of kinetic penetrator body that increases or decreases in outer diameter around its circumference from front to back such that the outer diameter is larger or smaller in the rear portion and tapers to a

smaller or flares to a larger outer diameter forward. Since the rear portion of penetrator body will generally have a larger or smaller rear diameter than the front portion, slip-over electronic guidance unit will engage the larger or smaller outer diameter rear portion of kinetic penetrator body, *i.e.* locking taper **330**. Such a configuration generally prevents slip-over electronic guidance unit from disengaging kinetic penetrator body when the hypersonic kinetic penetrator projectile **300** is accelerated in forward motion. The angle or rate of taper or flare is not limiting of the invention and any angle or rate of taper or flare is generally considered to be within the scope of the present invention.

[0025] In yet another embodiment of the present invention, the kinetic penetrator body and the slip-over guidance unit may have a locking taper **330**. In still another embodiment, the kinetic penetrator body and the slip-over guidance unit may each have a locking taper **330**. Where each have a locking taper **330**, the angle or rate of taper or flare may substantially match the corresponding seat so that a substantially snug fit may be obtained between the kinetic penetrator body and the slip-over guidance unit.

[0026] In yet another exemplary embodiment in accordance with the present invention, locking taper **330** may comprise a flare projection on a rear portion of kinetic penetrator body such that when slip-over guidance unit is slidably engaged from the forward end of kinetic penetrator body, the guidance unit engages on the flare projection. Flare projection may be, for example, a substantially abrupt change in outer diameter of kinetic penetrator body or one or more radially projecting mounts on the end of kinetic penetrator body,

and/or the like. Any mechanism for engaging slip-over electronic guidance unit on the rear portion of kinetic penetrator body may be alternatively, conjunctively or sequentially employed and will generally be considered to be within the scope of the present invention.

[0027] The rear portion of kinetic penetrator body may include a power source **310** and a tracer **320**. Power source **310** may comprise a battery that may be used *inter alia* to initiate tracer **320**. Tracer **320** may comprise a chemical tracer, such that hypersonic kinetic penetrator projectile **300** may be generally visibly tracked during flight. Tracer **320** may also comprise an electronic tracer utilizing, for example, radio frequency or infrared elements such that hypersonic penetrator projectile may be tracked visibly or electronically. In yet another exemplary embodiment, slip-over electronic guidance unit may include fins **340** suitably adapted to generally maintain a predetermined roll rate throughout the flight to the target.

[0028] Fig. 4 representatively illustrates a lateral cross-sectional view of a hypersonic kinetic penetrator projectile in accordance with an exemplary embodiment of the present invention. As representatively illustrated for example in Fig. 4, hypersonic kinetic penetrator projectile generally includes kinetic penetrator body **400**, kinetic penetrator body nose **420**, fin body **410** and computer board **430**. Fin body **410** may be a portion of slip-over electronic guidance unit suitably adapted to provide fins to hypersonic kinetic penetrator projectile. Computer board **430** may include guidance electronics such as a processor, a memory, an antenna, a transmitter, a receiver, a millimeter wave length wave emitter, and/or the like to provide telemetry and

receive guidance instructions from a receiver system located, for example, substantially remotely disposed from hypersonic kinetic penetrator projectile.

[0029] As noted *vide supra*, a substantially identical kinetic penetrator body and slip-over electronic guidance unit may be utilized in either a gun-launched munition round or a rocket motor assembly of a missile. In either case, hypersonic kinetic penetrator projectile may be accelerated to hypersonic velocity (e.g., in excess of mach 5) and separated from either the munition round or rocket motor assembly. In both cases, the projectile may be given a roll rate to average out any aerodynamic or thrust misalignments. For example, the gun firing the munition round may be rifled to induce spin in the munition round, or the rocket motor nozzles/fins may be curved so as to induce a roll rate during the boost phase of launch.

[0030] In an exemplary application in accordance with a representative embodiment of the present invention, the system may be adapted to include a launch vehicle subsystem and a projectile subsystem. The launch vehicle subsystem may comprise a Forward Looking Infra-red (FLIR) camera and a laser range finder to track and identify a target as well as to calculate target azimuth, elevation and range information. The launch vehicle subsystem may further comprise a transmitter, which radiates, for example, millimeter wave energy to the projectile subsystem (*i.e.*, hypersonic kinetic penetrator projectile) *via* a first antenna. Return signals from the projectile subsystem may be received by a second antenna, implemented, for example, in a phased array of polarized mono-pulse antenna elements, and passed to a receiver/computer. The receiver/computer may be suitably configured to

compute projectile roll angle in accordance with the system generally disclosed in U.S. Patent No. 6,016,990 entitled ALL-WEATHER ROLL ANGLE MEASUREMENT FOR PROJECTILES, Issued on Jan. 25, 2000 to James G. Small.

[0031] Hypersonic kinetic penetrator projectile may include at least one of a divert charge mounted on the slip-over guidance unit or a substantially moveable nose cone mounted on the kinetic penetrator body to perform target acquisition course correction during flight. The divert charge or the substantially moveable nose may be actuated *via* at least one of a radio frequency (RF) or a wired connection. Control signals to actuate either the divert charge or the moveable nose may be communicated or processed by, for example, the slip-over electronic guidance unit.

[0032] The slip-over electronic guidance unit of hypersonic kinetic penetrator projectile may include a continuous wave transmitter, an antenna system and a command receiver. The transmitter and receiver may be adapted to share the antenna system, although separate transmit and receive antennas may be employed in other alternative, conjunctive or sequential embodiments.

[0033] The transmit system employed in slip-over electronic guidance unit may be a linearly polarized transmit antenna system. In such an embodiment, a first transmitter may be configured to transmit a first transmit signal at a first frequency, while a second transmitter may be configured to transmit a second transmit signal at a second frequency. While first frequency and second frequency are generally different, first transmit signal and second transmit signal are generally in phase coherence.

- [0034]** A receiver system may be generally located at a ground launch vehicle site or in an aerial vehicle remotely disposed away from the hypersonic kinetic penetrator. The receiver system may include a linearly polarized receive antenna for receiving a first transmit signal and a second transmit signal. Both signals may be down-converted *via* a receiver section to a first receiver signal and a second receiver signal respectively, where first and second receiver signals are generally in phase coherence. The receiver system may also include a roll angle processor for processing first and second receiver signals to calculate roll angle of the kinetic penetrator projectile.
- [0035]** A command transmitter, optionally located with receiver system, may transmit course correction commands to slip-over guidance unit to effect target acquisition course correction using, for example, a real-time data link. The slip-over electronic guidance unit may actuate at least one of movement of moveable nose cone or firing of at least one divert charge based on received course correction data *via* at least one of an RF link or a wired communication link.
- [0036]** In yet another embodiment, receivers on slip-over electronic guidance unit of hypersonic kinetic penetrator projectile may be disposed to receive two substantially coherent linearly polarized signals from a remote receiver system in a radio line-of-sight of hypersonic kinetic penetrator projectile. Slip-over electronic guidance unit may include a GPS receiver for the determination of position. By receiving signals from remote receiver system, hypersonic kinetic penetrator projectile may determine its rotation angle relative to the direction of linear polarization of the transmitted signals.

Hypersonic kinetic penetrator projectile may thereafter initiate target acquisition course correction through actuating at least one of movement of moveable nose cone or firing of at least one divert charge.

[0037] The remote receiver system may guide a line-of-sight impact by tracking an emitter on slip-over electronic guidance unit of hypersonic kinetic penetrator projectile in a substantially similar field of view as the target being tracked. In such an embodiment, where an FLIR and laser range finder may be used to identify and track the target, an offset trajectory may be used for deployment of the hypersonic kinetic penetrator projectile so as not to obscure the line-of-sight field of view to the target.

[0038] The foregoing system generally has the advantage of increasing accuracy to the order of 0.1 milliradians, corresponding to a deviation of not more than 0.5 meters at a range of 5 kilometers. The probability of a hit on a target is substantially above 90%, while the miss distance for an unguided kinetic penetrator body is generally ten times greater. The slip-over electronic guidance unit may be used on a variety of ordinance platforms including gun-launched munitions and rocket-launched missiles that use a kinetic penetrator body. The disclosed system is capable of withstanding in excess of 70,000 g's of launch acceleration force. The disclosed system also simplifies logistics by effectively reducing the need for multiple launch systems, thereby substantially reducing costs.

[0039] In the foregoing specification, the invention has been described with reference to specific exemplary embodiments; however, it will be appreciated that various modifications and changes may be made without departing from

the scope of the present invention as set forth in the Claims below. The specification and figures are to be regarded in an illustrative manner, rather than a restrictive one and all such modifications are intended to be included within the scope of the present invention. Accordingly, the scope of the invention should be determined by the Claims appended hereto and their legal equivalents rather than by merely the examples described above.

[0040] For example, the steps recited in any method or process claims may be executed in any order and are not limited to the specific order presented in the Claims. Additionally, the components and/or elements recited in any apparatus claims may be assembled or otherwise operationally configured in a variety of permutations to produce substantially the same result as the present invention and are accordingly not limited to the specific configuration recited in the Claims.

[0041] Benefits, other advantages and solutions to problems have been described above with regard to particular embodiments; however, any benefit, advantage, solution to problem or any element that may cause any particular benefit, advantage or solution to occur or to become more pronounced are not to be construed as critical, required or essential features or components of any or all the Claims.

[0042] As used herein, the terms “comprise”, “comprises”, “comprising”, “having”, “including”, “includes” or any variation thereof, are intended to reference a non-exclusive inclusion, such that a process, method, article, composition or apparatus that comprises a list of elements does not include only those elements recited, but may also include other elements not expressly listed or

inherent to such process, method, article, composition or apparatus. Other combinations and/or modifications of the above-described structures, arrangements, applications, proportions, elements, materials or components used in the practice of the present invention, in addition to those not specifically recited, may be varied or otherwise particularly adapted to specific environments, manufacturing specifications, design parameters or other operating requirements without departing from the general principles of the same.

[0043] It is to be understood that, if any prior art publication is referred to herein, such reference does not constitute an admission that the publication forms a part of the common general knowledge in the art, in Australia or any other country.

[0044] In the claims which follow and in the preceding description of the invention, except where the context requires otherwise due to express language or necessary implication, the word "comprise" or variations such as "comprises" or "comprising" is used in an inclusive sense, i.e. to specify the presence of the stated features but not to preclude the presence or addition of further features in various embodiments of the invention.

2006232995 26 Feb 2010

CLAIMS

1. A projectile guidance system comprising:
a detachable launch system defining an inner volume;
5 a kinetic penetrator body at least partially enclosed
within the inner volume of the detachable launch system;
and
a slip-over guidance unit approximately forming an open
ended cylinder, wherein:
10 the slip-over guidance unit is enclosed within the inner
volume of the detachable launch system; and
the kinetic penetrator body longitudinally slidably mounts
to the slip over guidance unit through an open-ended
cylinder, wherein an exterior surface portion of the
15 kinetic energy penetrator body engages the inner surface
of the open-ended cylinder before the projectile is
launched.
2. The projectile guidance system of claim 1, wherein the
slip-over guidance unit engages with the kinetic
20 penetrator body via at least one of a taper and flare.
3. The projectile guidance system of claim 1 or claim 2
wherein:
the slip-over guidance unit is stored in a forward portion
of a rocket motor assembly;
25 the kinetic penetrator body is stored within an aft
portion of the rocket motor assembly; and
the kinetic penetrator body is repositioned to engage the
slip-over guidance unit before launch.
4. The projectile guidance system of any one of the
30 preceding claims, wherein the slip-over guidance unit
comprises a transmit system, the transmit system
comprising a linearly polarized transmit antenna system, a
first transmitter coupled to the transmit antenna system
for transmitting a first transmit signal at a first
35 frequency, a second transmitter coupled to the transmit
antenna system for transmitting a second transmit signal

at a second frequency, wherein the first frequency is different from the second frequency, and the first transmit signal and the second transmit signal are in phase coherence.

5 5. The projectile guidance system of any one of the preceding claims, wherein the system includes at least one of a divert charge mounted on the slip-over guidance unit and a substantially moveable nose mounted on the kinetic penetrator body, wherein the moveable nose is configured
10 to pivot relative to the kinetic penetrator body.

6. The projectile guidance system of any one of the preceding claims, wherein a millimetre wavelength wave emitter is carried in a rear portion of the kinetic penetrator body.

15 7. The projectile guidance system of any one of the preceding claims, wherein the kinetic penetrator body comprises at least one of tungsten, carbide steel, and depleted uranium.

8. The projectile guidance system of claim 5, wherein at
20 least one of the moveable nose and the divert charge is actuated via at least one of an RF and a wired communication.

9. The projectile guidance system of claim 8, wherein
25 control signals are at least one of communicated from and processed by the slip-over guidance unit.

10. A kinetic energy projectile device, comprising:
a detachable exterior shell;
a slip-over electronic guidance unit forming an open-ended cylinder with an exposed inner surface, wherein the slip-
30 over electronic guidance unit is enclosed within the detachable exterior shell;
a kinetic penetrator body disposed at least partially within the detachable exterior shell, wherein:
the kinetic penetrator body longitudinally slidably mounts
35 to the slip-over guidance unit through the inner surface of the slip-over electronic guidance unit prior to the kinetic energy projectile device launching;

2006232995 26 Feb 2010

the slip-over electronic guidance unit engages with the kinetic penetrator body via at least one of a locking taper and a flare; and

at least one of a divert charge disposed on the slip-over electronic guidance unit and a substantially moveable nose disposed on the kinetic penetrator body, wherein the moveable nose is configured to pivot relative to the kinetic penetrator body.

11. The kinetic energy projectile device of claim 10, wherein slip-over electronic guidance unit comprises a transmit system, the transmit system comprising a linearly polarized transmit antenna system, a first transmitter coupled to the transmit antenna system for transmitting a first transmit signal at a first frequency, a second transmitter coupled to the transmit antenna system for transmitting a second transmit signal at a second frequency, wherein the first frequency is different from the second frequency, and the first transmit signal and the second transmit signal are in phase coherency.

12. The kinetic energy projectile device of claim 10, wherein the slip-over electronic guidance unit further comprises a millimetre wavelength emitter.

13. A method for command guiding a hypersonic projectile, said method comprising steps of:

providing a detachable launch system defining an inner volume;

providing a kinetic penetrator at least partially enclosed within the inner volume of the detachable launch system;

providing a slip-over electronic guidance unit

approximately forming an open-ended cylinder, wherein: the slip-over guidance unit is enclosed within the inner volume of the detachable launch system; and

the kinetic penetrator body is suitably configured to longitudinally slidably mount to the slip-over electronic guidance unit through the open-ended cylinder, wherein an exterior surface portion of the kinetic energy penetrator body engages an inner surface of the open-ended cylinder

before the projectile is launched; and
at least one of:

5 providing at least one of a divert charge disposed on
the slip-over electronic guidance unit and a substantially
moveable nose disposed on the kinetic penetrator body; and
providing at least one divert charge disposed on the
penetrator body.

10 14. The method of claim 13, further comprising the step of
engaging the slip-over electronic guidance unit with the
kinetic penetrator body via at least one of a locking
taper and a flare.

15 15. The method of claim 13 or claim 14, further comprising
the step of:

providing a transmit system communicatively coupled to the
slip-over electronic guidance unit, the transmit
system comprising a linearly polarized transmit
antenna system, a first transmitter coupled to the
transmit antenna system for transmitting a first
transmit signal at a first frequency, a second
20 transmitter coupled to the transmit antenna system
for transmitting a second transmit signal at a second
frequency, wherein the first frequency is different
from the second frequency, and the first transmit
signal and the second transmit signal are in phase
coherence;

25 providing a receiver system located substantially
remotely from the hypersonic kinetic penetrator
projectile, the receiver system comprising a linearly
polarized receive antenna system for receiving the first
30 transmit signal and the second transmit signal, a first
receiver section for receiving and downconverting the
first transmit signal to provide a first receiver signal,
and a second receiver section for receiving and
downconverting the second transmit signal to provide a
35 second receiver signal, wherein the first and second
receiver signals are in phase coherence; and

providing a roll angle processor responsive to the receiver system for calculating a roll angle of the hypersonic penetrator projectile.

5 16. The method of claim 13, further comprising the step of at least one of tracking and identifying a target using a forward-looking infrared camera system.

10 17. The method of claim 16, further comprising the step of guiding a line-of sight impact by tracking an emitter on the hypersonic kinetic penetrator projectile in a substantially similar field of view as the target being tracked.

15 18. The method of claim 17, further comprising the step of communicating guidance commands to the hypersonic kinetic penetrator projectile via a substantially real-time data link.

19. The method of claim 13, further comprising the step of using an offset trajectory so as to not substantially obscure the line-of-sight field of view to target.

20 20. The method of claim 13, further comprising the step of actuating at least one of the movement of the substantially moveable nose and firing of at least one divert change to perform a target acquisition course correction.

25 21. The projectile guidance system of any one of claims 1 to 9, wherein the kinetic penetrator body and the slip-over guidance unit are interchangeably at least partially enclosed within the inner volume of the detachable launch system having a first diameter and an inner volume of an alternative detachable launch system having a second diameter.

30 22. The projectile guidance system of claim 21, wherein each detachable launch system comprises at least one of a munition round having the first diameter and a rocket motor assembly having the second diameter.

35 23. The projectile guidance system of claim 10, wherein the kinetic penetrator body and the slip-over electronic guidance unit are interchangeably at least partially

enclosed within the inner volume of the detachable exterior shell having a first diameter and an inner volume of an alternative detachable exterior shell having a second diameter.

5 24. The projectile guidance system of claim 23, wherein each detachable exterior shell comprises at least one of a munition round having the first diameter and a rocket motor assembly having the second diameter.

10 25. A projectile guidance system substantially as herein described with reference to the accompanying drawings.

26. A kinetic energy projectile device substantially as herein described with reference to the accompanying drawings.

15 27. A method for command guiding a hypersonic projectile substantially as herein described with reference to the accompanying drawings.

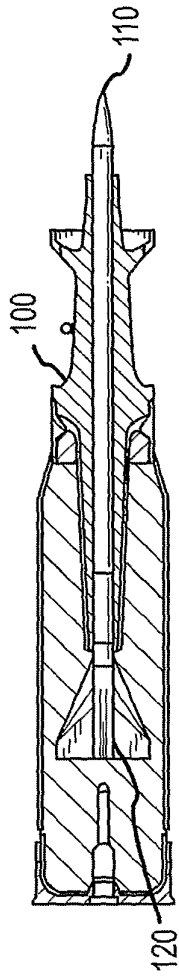

FIG. 1

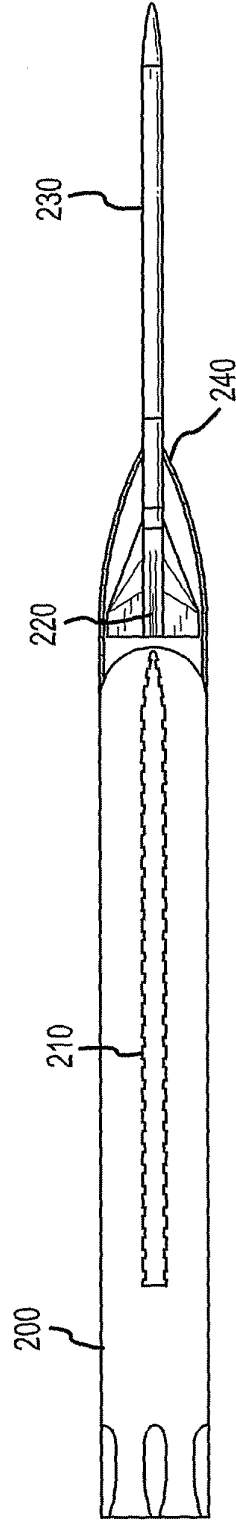

FIG. 2

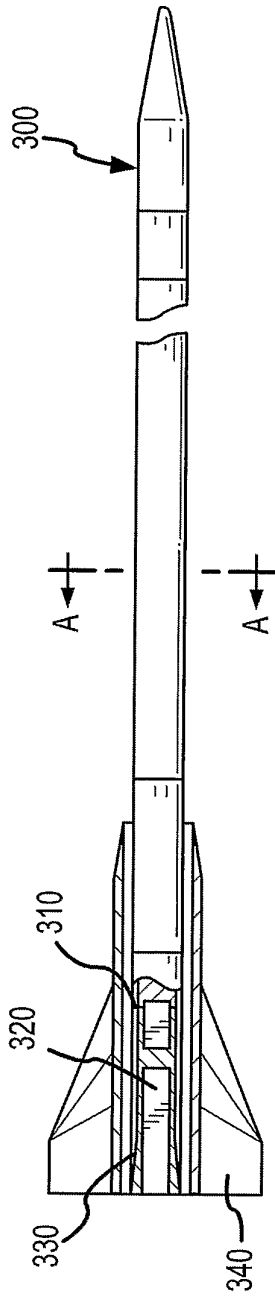
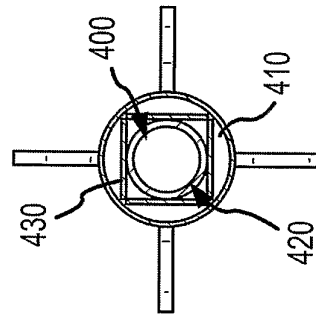

FIG.3



VIEW A-A

FIG.4