

No. 684,064.

Patented Oct. 8, 1901.

I. N. INKS.
DUMPING WAGON.

(Application filed Aug. 28, 1900.)

(No Model.)

3 Sheets—Sheet 1.

Fig. 1.

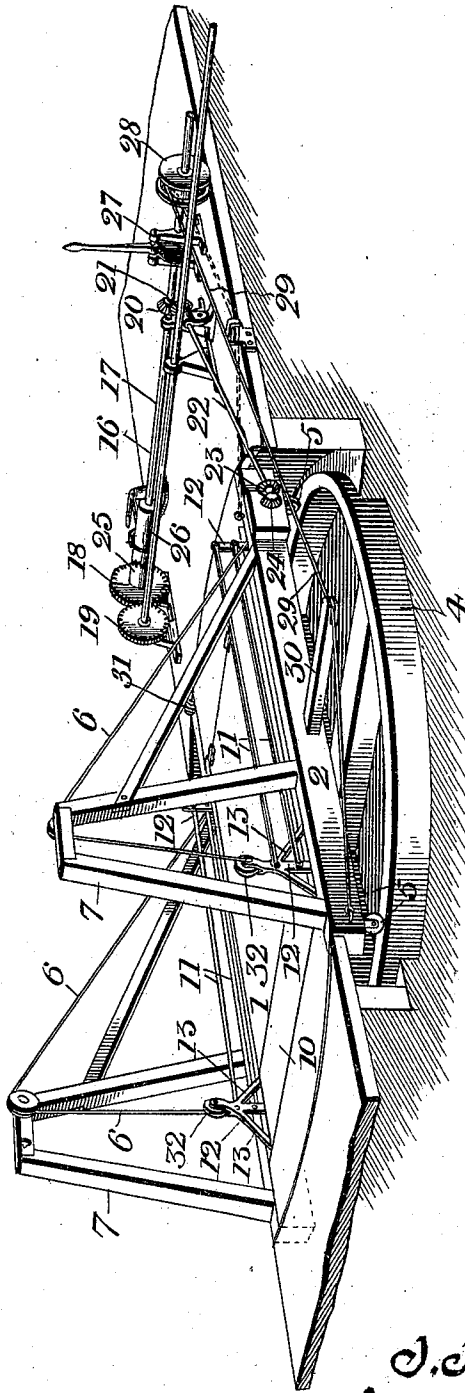

WITNESSES:
L. C. Mills.
Clarence Shaw.

INVENTOR:
J. N. Inks.
BY *O'neal & Co.*
Attorneys

I. N. INKS.
DUMPING WAGON.

(Application filed Aug. 28, 1900.)

(No Model.)

3 Sheets—Sheet 2.

Fig. 2.

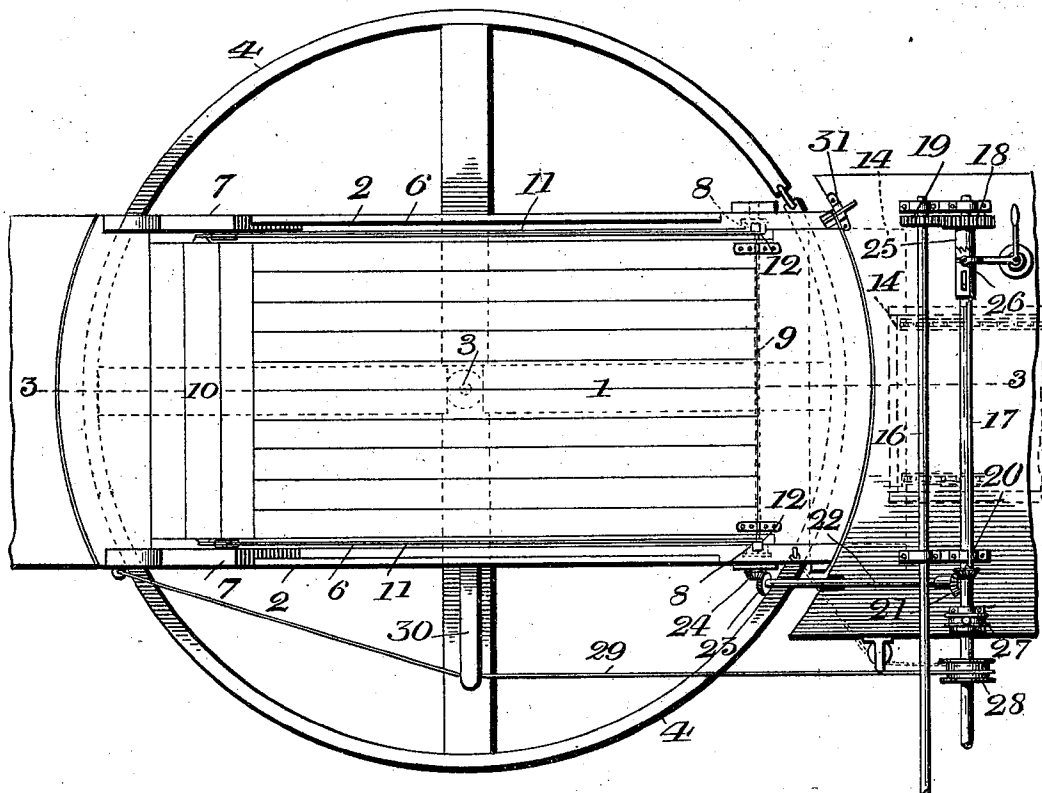
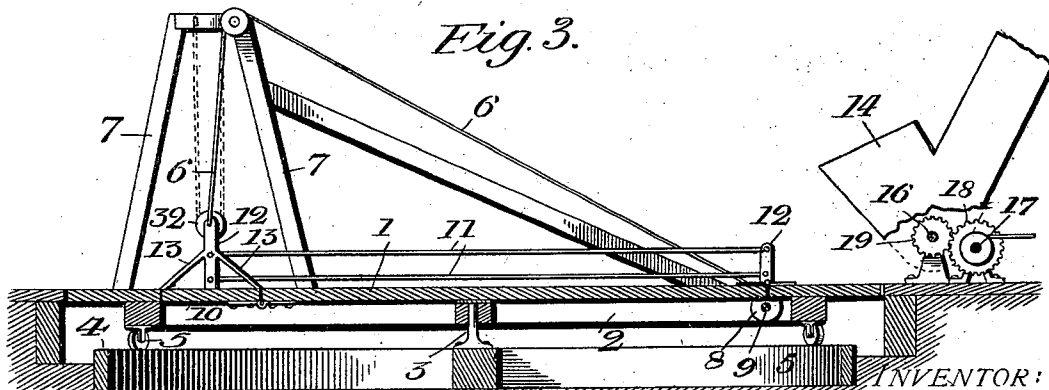

Fig. 3.



WITNESSES:

L. C. Hills
Clarna Shaw

BY

I. N. Inks
Howard Co
Attorneys

No. 684,064.

Patented Oct. 8, 1901.

I. N. INKS.
DUMPING WAGON.

(Application filed Aug. 28, 1900.)

(No Model.)

3 Sheets—Sheet 3.

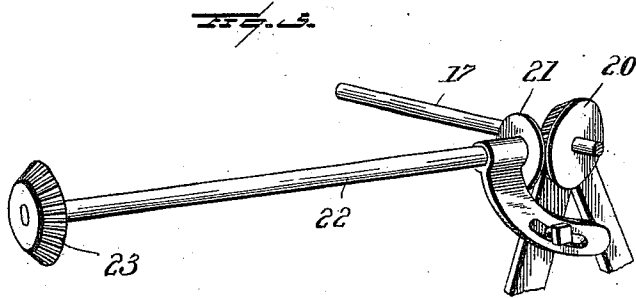
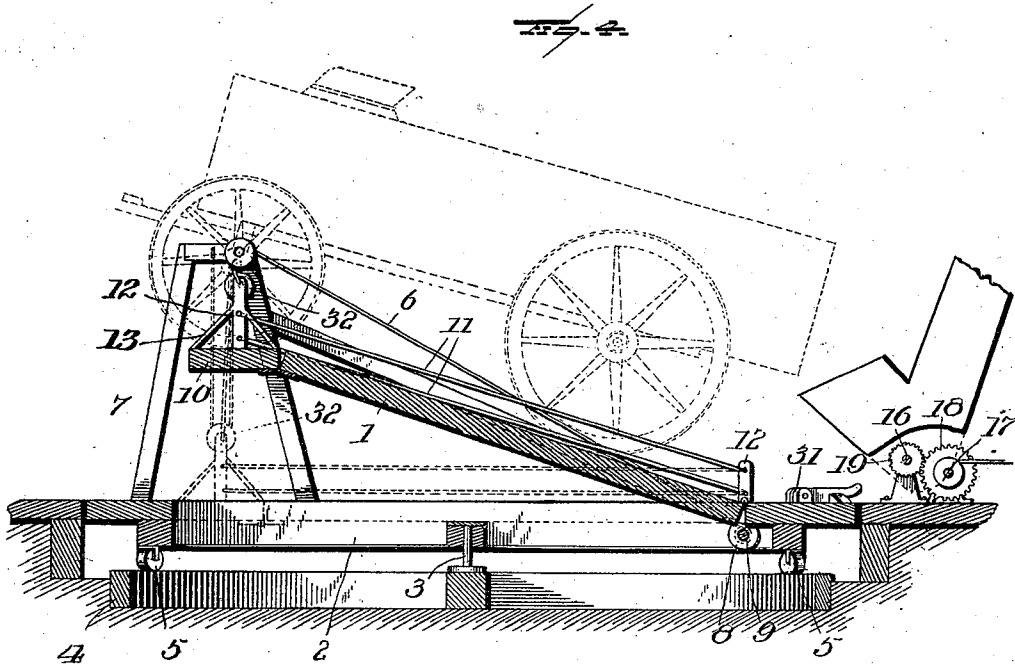

WITNESSES:

L. C. Hills.
[Signature]

INVENTOR

I. N. INKS.

BY

[Signature]
Attorney

UNITED STATES PATENT OFFICE.

ISAAC NEWTON INKS, OF RANSOM, ILLINOIS.

DUMPING-WAGON.

SPECIFICATION forming part of Letters Patent No. 684,064, dated October 8, 1901.

Application filed August 28, 1900. Serial No. 28,366. (No model.)

To all whom it may concern:

Be it known that I, ISAAC NEWTON INKS, a citizen of the United States, residing at Ransom, in the county of Lasalle and State of Illinois, have invented a new and useful Dumping-Wagon, of which the following is a specification.

My invention relates to wagon-dumps or devices for elevating one end of the wagon to such an extent that the contents of the bed will fall out of the lower end; and it has for its object to produce a device of this kind which will be positive in its operations and which will be connected with an elevator in such a manner that as the contents are discharged from the wagon-bed they will be taken by the elevator and deposited where desired.

With this object in view my invention consists in the improved construction and novel arrangement of parts of a combined wagon-dump and elevator, as will be hereinafter more fully set forth.

In the accompanying drawings, in which the same reference-numerals indicate corresponding parts in each of the views in which they occur, Figure 1 is a perspective view of my improved wagon-dump, the elevator for carrying off the contents delivered from the wagon being removed for the purpose of better showing the mechanism arranged upon the rear end of the dump. Fig. 2 is a plan view of the dump in the same position as Fig. 1, the elevator, however, being shown in dotted lines. Fig. 3 is a central longitudinal sectional view of the same, the view being taken about on the line 3 3 of Fig. 2, some of the parts being shown in two positions, the elevator being shown in full lines with the lower end broken away for the purpose of showing the gearing. Fig. 4 is a longitudinal sectional view of the dump, showing the table raised and a wagon in position thereon, the wagon being shown in dotted lines, the lower end of the elevator being shown as in Fig. 3. Fig. 5 is a detail perspective view showing a portion of the mechanism for elevating the forward end of the table.

In practicing my invention I mount a table or platform 1 within a frame 2, which latter is centrally mounted upon a pin or support 3

in the manner of the ordinary turn-table. The frame and platform may be constructed in any desired manner and are of sufficient size to permit of a loaded wagon being driven onto the platform from one end. The ends of the frame are preferably mounted upon a track 4 by means of four wheels 5, one at each corner.

The platform 1 is pivotally mounted in one end of the frame 2 in any suitable manner, and its free end is adapted to be moved vertically by means of ropes or cables 6, which are secured to a table connected with said platform and pass over pulleys or other suitable supports at the tops of two frames or standards 7, one upon each side of the frame 2. The free ends of the cables are wound upon drums 8 on a shaft 9, which is journaled in bearings on the frame 2, near the pivotal end of the platform.

The free end of the platform 1 is provided with a table 10, which is pivotally secured thereon, so as to be held in a horizontal plane while the front of the frame is being moved upward into an inclined position. The table is held in its horizontal position by means of two pairs of stays 11, which are preferably located upon both sides of the dump, although it is evident that one pair of stays might be dispensed with. The stays are pivotally secured at their ends one above the other to standards 12, the standards upon the frame being located at the pivotal end of the platform 1 and the standards on the table projecting upward from the ends thereof. Bracerods 13 are secured at their ends to the edges of the table 10 and are secured at their intermediate portions to the standards for the purpose of adding sufficient strength to the table to prevent its being accidentally broken.

Any suitable elevator 14 may be located at what I shall call the "rear" end of the dump and is driven from any suitable motor or horse-power (not shown) by means of the driving-shaft 16. A shaft 17 is mounted adjacent to the driving-shaft 16 and is provided at one end with a gear-wheel 18, which is driven by a pinion 19 upon the driving-shaft. The opposite end of the shaft is provided with a bevel-wheel 20, which meshes with a corresponding bevel-wheel 21, secured upon

one end of a shaft 22, journaled in an adjustable bearing, as shown in Fig. 5, the free end of said shaft being movable vertically and provided with a bevel-pinion 23, which meshes with a bevel-wheel 24 at one end of the shaft 9 for the purpose of rotating said shaft and the drums 8 to raise the front end of the platform. The shaft 17 is provided with a sleeve 25 and clutch 26, by means of which the elevation of the platform may be effected. A brake 27 can be so arranged as to engage with said elevating mechanism and hold the platform at any desired angle after the clutch 26 has been disconnected. If desired, a drum 28 may be located upon the shaft 17 for the engagement therewith of a rope 29, which is secured to the forward end of the frame 2 and has its intermediate portion passed over a laterally-extending bracket 30 or projecting arm from the side of the frame 2.

A suitable latch or locking device 31 may be arranged adjacent to the end of the frame in position to engage therewith and hold the frame against rotation whenever desired, and, if desired, each hoisting-rope may have its end secured to the upper portion of the standards 7 and be passed through a pulley 32 upon the end of the table 10 to secure sufficient leverage for hoisting the heaviest loads which it may be desired to discharge with the dump.

In using my improved dump and elevator they are located where desired, with the frame and platform of the dump capable of being rotated completely around in either direction. The loaded wagon is then driven onto the platform from the rear until its front wheels rest upon the table at the front end of the platform. The horses are then detached from the wagon and hitched to the motor or horse-power in the ordinary manner. The motor is then operated until the rope from the front end of the frame is wound upon its pulley sufficiently to turn the frame around, with its rear end adjacent to the elevator. As soon as the frame reaches this point it is locked in position and the rope disconnected from its drum. The shaft 22 is then lowered until the bevel-wheel 23 upon its free end is in engagement with the bevel-wheel 24 upon the end of the shaft 9, and thereby virtually connects the motor with the platform through the hoisting-ropes 6 and the drums 8. The motor is then started, which will gradually wind the hoisting-ropes upon their respective drums and gradually raise the front of the platform and wagon into an inclined position. As soon as the front end of the wagon rises the contents of the bed will pass out at the rear end, the end-gate having been removed, and into the elevator and from there into the bin or other receptacle. As the front of the wagon continues to rise the contents of the bed will be gradually emptied into the elevator without danger of choking or overloading the elevator. If the discharge should

be too rapid at any time for the capacity of the elevator, the elevation of the wagon is stopped by means of the clutch and held in that position until after the elevator has disposed of the surplus material, after which the elevation of the wagon may be resumed by means of the clutch. After the load has been discharged the power is stopped, and the front ends of the platform and wagon are gradually let down to their normal positions by means of the brake mechanism. The horses are then taken from the motor and hitched to the wagon and the wagon drawn off the dump, after which the frame is unlocked and swung upon its pivot into position to receive another load. By pivotally securing the table 10 at the front of the platform 1 and holding it in a horizontal plane by means of the stays 11 the wagon is prevented from running down the inclined platform when its forward end is elevated. In this manner the wagon is held in position by the ordinary rub-lock or brake without the use of cleats or other retaining devices upon the platform, thereby securing a perfectly level platform for the entrance of the wagon, as the table and platform will lie in the same plane when the platform is at its lowest point.

As above described, it will be seen that my improved dump and elevator are effective in all of their operations, and a load of grain or other material can be quickly discharged without manual labor, and they can be conveniently located adjacent to the receptacle into which it is desired to discharge the contents of the wagon. All of the parts can be made so light that they can be readily transported from place to place, thereby particularly adapting them to the use of the farmer who may desire to use them for different purposes and in different positions at different seasons of the year.

Although I have shown what I consider the most desirable form of manufacturing my dump, yet I reserve the right to make such changes and alterations therein as will come within the scope of my invention.

Having thus fully described my invention, what I claim as new, and desire to secure by Letters Patent, is—

1. The combination, with a dump and an elevator, of means for operating the dump simultaneously and from a common motor with the operation of the elevator, substantially as described.

2. The combination, with a dump and an elevator, of a rope for swinging the dump horizontally and another for moving it vertically, and means for operating said ropes from the elevator mechanism, the elevating-ropes being operated simultaneously with the operation of the elevator, substantially as described.

3. The combination, with a frame provided with standards at one end, of a platform pivotally secured at the opposite end, a table

pivotaly secured at the front end of the platform, a hoisting-rope from the table to the top of the standards, and means for holding the table in horizontal position, substantially as described.

4. The combination, with a frame provided with hoisting-standards upon each side thereof at one end, a platform pivotaly secured at the opposite end of said frame, a table pivotaly secured at the free end of the platform, said table and frame being provided with standards, stays connected at their ends to said standards, and a hoisting-rope from the front end of the platform to the tops of the hoisting-standards, substantially as described.

5. The combination, with a frame and an elevator, of a platform pivotaly secured to one end of the frame, a shaft journaled at said end of the frame provided with a drum at each end, standards at the opposite end of said frame, a hoisting-pulley secured to the free end of said platform upon each side and passing over the top of its respective standard and wound upon its respective drum, and de-

tachable means from the elevator mechanism to said shaft, substantially as described.

6. The combination of a platform having a table jointed thereto, means for operating said parts in unison and for presenting the platform in an inclined position and the table at a horizontal position, substantially as described.

7. The combination, with a dump and an elevator, the hoisting mechanism of the dump being provided with a bevel-wheel, a shaft journaled adjacent to the drive-shaft of the elevator, one end of which is provided with a bevel-gear, a shaft provided with a bevel-gear at each end in position to engage with the bevel-wheels on said shaft and on the hoisting mechanism respectively, a drum on said shaft, and a clutch and a brake for controlling the operation of said drum and bevel-wheels, substantially as described.

ISAAC NEWTON INKS.

Witnesses:

GEO. R. SHEAR,
JOHN B. THOMPSON.