

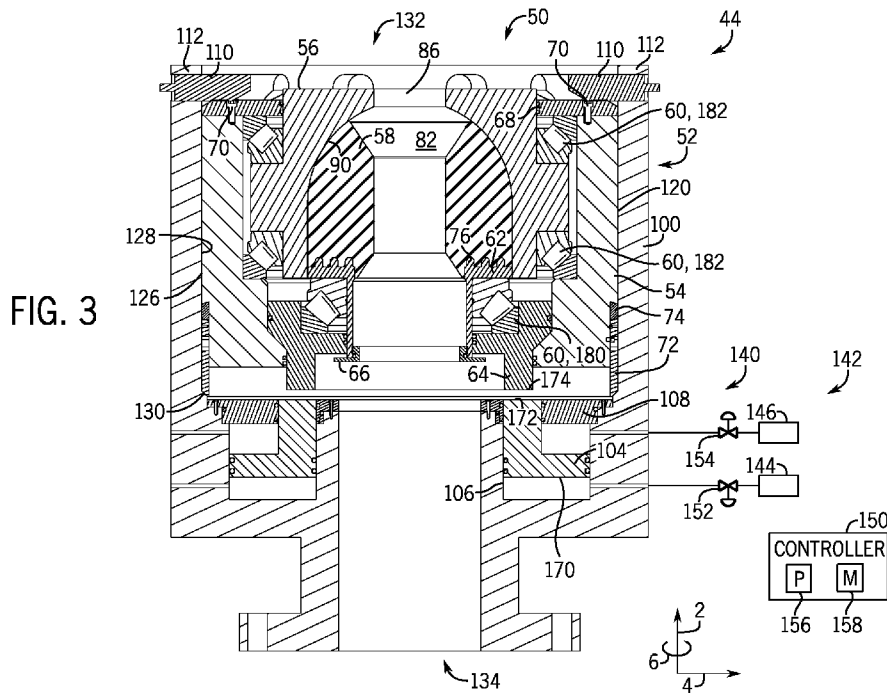

- (51) International Patent Classification:  
E21B 33/08 (2006.01) E21B 33/06 (2006.01)  
E21B 34/14 (2006.01)
- (21) International Application Number:  
PCT/US2024/020484
- (22) International Filing Date:  
19 March 2024 (19.03.2024)
- (25) Filing Language: English
- (26) Publication Language: English
- (30) Priority Data:  
202311019451 21 March 2023 (21.03.2023) IN
- (71) Applicant (for US only): **SCHLUMBERGER TECHNOLOGY CORPORATION** [US/US]; 300 Schlumberger Drive, Sugar Land, Texas 77478 (US).
- (71) Applicant (for CA only): **SCHLUMBERGER CANADA LIMITED** [CA/CA]; 125 – 9 Avenue SE, Calgary, Alberta T2G 0P6 (CA).
- (71) Applicant (for FR only): **SERVICES PETROLIERS SCHLUMBERGER** [FR/FR]; 42 rue Saint Dominique, 75007 Paris (FR).
- (71) Applicant (for all designated States except CA, FR, US): **SCHLUMBERGER TECHNOLOGY B.V.** [NL/NL]; Parkstraat 83, 2514 JG The Hague (NL).
- (72) Inventors: **PISE, Neha Yashodhan**; Survey No 144-145 Samrat Ashok Path, State of Maharashtra, Pune 411006 (IN). **PETA, Madhu Sudhana Rao**; Commerzone, Yerawada, Samrat Ashok Path, Off Airport, 7th Floor, Building No. 6, Pune 411006 (IN). **JAIN, Akshay**; Samrat Ashok Path-Off Airport Road, Pune 411006 (IN).
- (74) Agent: **MCKINNEY, Kelly** et al.; Schlumberger, 10001 Richmond Avenue, Room 4720, Houston, Texas 77042 (US).
- (81) Designated States (unless otherwise indicated, for every kind of national protection available): AE, AG, AL, AM, AO, AT, AU, AZ, BA, BB, BG, BH, BN, BR, BW, BY, BZ, CA, CH, CL, CN, CO, CR, CU, CV, CZ, DE, DJ, DK, DM, DO, DZ, EC, EE, EG, ES, FI, GB, GD, GE, GH, GM, GT, HN, HR, HU, ID, IL, IN, IQ, IR, IS, IT, JM, JO, JP, KE, KG,

(54) Title: ROTATING CONTROL DEVICE WITH SPLIT PISTON



(57) Abstract: A rotating control device (RCD) for a drilling system includes a seal assembly with a seal assembly housing, a seal element positioned within the seal assembly housing, and a piston positioned within the seal assembly housing. The piston is configured to drive the seal element axially within the seal assembly housing to enable the seal element to form an annular seal about a tubular as the tubular rotates, moves axially, or both.



KH, KN, KP, KR, KW, KZ, LA, LC, LK, LR, LS, LU, LY,  
MA, MD, MG, MK, MN, MU, MW, MX, MY, MZ, NA,  
NG, NI, NO, NZ, OM, PA, PE, PG, PH, PL, PT, QA, RO,  
RS, RU, RW, SA, SC, SD, SE, SG, SK, SL, ST, SV, SY, TH,  
TJ, TM, TN, TR, TT, TZ, UA, UG, US, UZ, VC, VN, WS,  
ZA, ZM, ZW.

**(84) Designated States** (*unless otherwise indicated, for every kind of regional protection available*): ARIPO (BW, CV, GH, GM, KE, LR, LS, MW, MZ, NA, RW, SC, SD, SL, ST, SZ, TZ, UG, ZM, ZW), Eurasian (AM, AZ, BY, KG, KZ, RU, TJ, TM), European (AL, AT, BE, BG, CH, CY, CZ, DE, DK, EE, ES, FI, FR, GB, GR, HR, HU, IE, IS, IT, LT, LU, LV, MC, ME, MK, MT, NL, NO, PL, PT, RO, RS, SE, SI, SK, SM, TR), OAPI (BF, BJ, CF, CG, CI, CM, GA, GN, GQ, GW, KM, ML, MR, NE, SN, TD, TG).

**Published:**

— *without international search report and to be republished upon receipt of that report (Rule 48.2(g))*

## ROTATING CONTROL DEVICE WITH SPLIT PISTON

### CROSS REFERENCE TO RELATED APPLICATION

**[0001]** This application claims priority to Indian Patent Application No. 202311019451, filed on March 21, 2023, the entirety of which is incorporated by reference herein.

### BACKGROUND

**[0002]** This section is intended to introduce the reader to various aspects of art that may be related to various aspects of the present disclosure, which are described and/or claimed below. This discussion is believed to be helpful in providing the reader with background information to facilitate a better understanding of the various aspects of the present disclosure. Accordingly, it should be understood that these statements are to be read in this light, and not as admissions of prior art.

**[0003]** Natural resources have a profound effect on modern economies and societies. In order to meet the demand for such natural resources, numerous companies invest significant amounts of time and money in searching for, accessing, and extracting oil, natural gas, and other natural resources. Particularly, once a desired natural resource is discovered below the surface of the earth, drilling systems are often employed to access the desired natural resource. These drilling systems can be located onshore or offshore depending on the location of the desired natural resource. Such drilling systems may include a drilling fluid system configured to circulate drilling fluid into and out of a wellbore to facilitate drilling the wellbore.

### BRIEF DESCRIPTION

**[0004]** A summary of certain embodiments disclosed herein is set forth below. It should be understood that these aspects are presented merely to provide the

reader with a brief summary of these certain embodiments and that these aspects are not intended to limit the scope of this disclosure. Indeed, this disclosure may encompass a variety of aspects that may not be set forth below.

**[0005]** In certain embodiments, a rotating control device (RCD) for a drilling system includes a seal assembly with a seal assembly housing, a seal element positioned within the seal assembly housing, and a piston positioned within the seal assembly housing. The piston is configured to drive the seal element axially within the seal assembly housing to enable the seal element to form an annular seal about a tubular as the tubular rotates, moves axially, or both.

**[0006]** In certain embodiments, a rotating control device (RCD) for a drilling system includes a seal assembly with a seal assembly housing, a seal element positioned within the seal assembly housing, and a piston positioned within the seal assembly housing. The RCD also includes a spool with a spool housing that defines a spool recess configured to receive the seal assembly and a spool piston that is configured to move within the spool housing. The spool piston is configured to contact and drive the piston toward the seal element to cause the seal element to form an annular seal about a tubular when the seal assembly is positioned in the spool recess.

**[0007]** In certain embodiments, a method of operating a drilling system includes fastening a spool to a component of the drilling system. The method also includes placing a seal assembly into the spool to form a rotating control device (RCD). The method further includes actuating a split piston system comprising a spool piston supported in a chamber of the spool and a piston supported in a seal assembly housing of the seal assembly to compress a seal element of the seal assembly to form an annular seal about a tubular. The method further includes rotating the tubular, moving the tubular axially, or both while the seal element forms the annular seal about the tubular.

**BRIEF DESCRIPTION OF THE DRAWINGS**

**[0008]** Various features, aspects, and advantages of the present disclosure will become better understood when the following detailed description is read with reference to the accompanying figures in which like characters represent like parts throughout the figures, wherein:

**[0009]** FIG. 1 is a schematic diagram of a drilling system with a rotating control device (RCD), in accordance with an embodiment of the present disclosure;

**[0010]** FIG. 2 is a cross-sectional view of a seal assembly and a spool that may be used in the RCD of FIG. 1, in accordance with an embodiment of the present disclosure;

**[0011]** FIG. 3 is a cross-sectional side view of the seal assembly of FIG. 2 positioned in the spool of FIG. 2, in accordance with an embodiment of the present disclosure;

**[0012]** FIG. 4 is a schematic cross-sectional side view of a portion of a seal element that may be used in the seal assembly of FIG. 2, wherein the seal element is in a relaxed configuration, in accordance with an embodiment of the present disclosure;

**[0013]** FIG. 5 is a schematic cross-sectional side view of the portion of the seal element of FIG. 4, wherein the seal element is in a compressed configuration, in accordance with an embodiment of the present disclosure;

**[0014]** FIG. 6 is a schematic cross-sectional side view of the portion of the seal element of FIG. 4, wherein the seal element is in the compressed configuration and in contact with a radially expanded portion of a tubular, in accordance with an embodiment of the present disclosure;

**[0015]** FIG. 7 is a schematic cross-sectional side view of the portion of the seal element of FIG. 4, wherein the seal element is in the compressed configuration and in contact with the radially expanded portion of the tubular along an entirety of an axial length of the seal element, in accordance with an embodiment of the present disclosure; and

**[0016]** FIG. 8 is a cross-sectional side view of a seal assembly and a spool that may be used in the RCD of FIG. 1, wherein a seal element includes inserts, in accordance with an embodiment of the present disclosure.

### **DETAILED DESCRIPTION OF SPECIFIC EMBODIMENTS**

**[0017]** One or more specific embodiments of the present disclosure will be described below. These described embodiments are only exemplary of the present disclosure. Additionally, in an effort to provide a concise description of these exemplary embodiments, all features of an actual implementation may not be described in the specification. It should be appreciated that in the development of any such actual implementation, as in any engineering or design project, numerous implementation-specific decisions must be made to achieve the developers' specific goals, such as compliance with system-related and business-related constraints, which may vary from one implementation to another. Moreover, it should be appreciated that such a development effort might be complex and time consuming, but would nevertheless be a routine undertaking of design, fabrication, and manufacture for those of ordinary skill having the benefit of this disclosure.

**[0018]** When introducing elements of various embodiments, the articles "a," "an," "the," "said," and the like, are intended to mean that there are one or more of the elements. The terms "comprising," "including," "having," and the like are intended to be inclusive and mean that there may be additional elements other than the listed elements. The use of "top," "bottom," "above," "below," and variations of these terms is made for convenience, but does not require any particular orientation of the components relative to some fixed reference, such as a direction of gravity.

**[0019]** A drilling system may include a drilling fluid system that is configured to circulate drilling fluid into and out of a wellbore to facilitate drilling the wellbore. For example, the drilling fluid system may provide a flow of the drilling fluid through a tubular (e.g., drill string) as the tubular rotates a drill bit that is positioned at a distal end portion of the tubular. The drilling fluid may exit through one or more openings

at the distal end portion of the tubular and may return toward a platform of the drilling system via an annular space between the tubular and a casing that lines the wellbore.

**[0020]** In some cases, the drilling system may use managed pressure drilling (“MPD”). MPD regulates a pressure and a flow of the drilling fluid within the tubular so that the flow of the drilling fluid does not over pressurize a well (e.g., expand the well) and/or blocks the well from collapsing under its own weight. The ability to manage the pressure and the flow of the drilling fluid enables use of the drilling system to drill in various locations, such as locations with relatively softer sea beds.

**[0021]** Embodiments of the present disclosure relate generally to a rotating control device (RCD) with a seal assembly that is configured to seal against a tubular (e.g., drill string) that extends through the RCD. More particularly, the seal assembly includes a seal element (e.g., annular seal element) that is configured to contact the tubular to form an annular seal that extends circumferentially about the tubular. The seal element may form the annular seal about the tubular as the tubular rotates and/or moves axially within the wellbore. In some embodiments, the seal assembly may include one or more bearings to facilitate rotation of the seal element with the tubular as the tubular rotates and/or moves axially within the wellbore (e.g., the seal element may be driven to rotate by the tubular).

**[0022]** It should be appreciated that the annular seal formed between the seal assembly and the tubular extending through the RCD may block fluid flow through an annular space that surrounds the tubular. For example, the annular seal may block drilling fluid, cuttings, and/or natural resources (e.g., carbon dioxide, hydrogen sulfide) from passing across the RCD from the wellbore toward a platform. In some embodiments, the fluid flow may be diverted toward another suitable location (e.g., a collection tank) other than the platform.

**[0023]** Advantageously, the seal assembly may be removably coupled (e.g., inserted) into a spool to form the RCD. Additionally, the seal assembly and the spool may each include respective piston elements that form a split piston actuation system for the RCD. The split piston actuation system may drive the

seal element from a relaxed configuration to a compressed configuration to enable the seal element to form the annular seal about the tubular.

**[0024]** However, as the tubular moves axially through the RCD, the seal element may deform (e.g., increase and decrease its inner diameter), which induces stress in the seal element. Thus, maintenance operations may be performed to inspect and/or to replace the seal assembly at certain times (e.g., after a particular number of hours in operation). The seal assembly and the spool disclosed herein enable efficient removal, installation, replacement, and/or other maintenance operations (e.g., replacement of the seal assembly without removal of the spool). Further, the split piston actuation system may provide active control to adjust the seal element, which may facilitate a desirable level of sealing force against the tubular, for example. In this way, the RCD may have lower maintenance costs, more efficient maintenance operations, more reliable sealing, and so forth.

**[0025]** FIG. 1 is a schematic diagram that illustrates an embodiment of a drilling system 10 that is configured to carry out drilling operations. The drilling system 10 may be a subsea system, although the disclosed embodiments may be used in a land-based (e.g., surface) system. The drilling system 10 may use MPD techniques. As illustrated, the drilling system 10 includes a wellhead assembly 12 coupled to a mineral deposit 14 via a well 16 having a wellbore 18.

**[0026]** The wellhead assembly 12 may include or be coupled to multiple components that control and regulate activities and conditions associated with the well 16. For example, the wellhead assembly 12 generally includes or is coupled to pipes, bodies, valves, and seals that enable drilling of the well 16, route produced minerals from the mineral deposit 14, provide for regulating pressure in the well 16, and provide for the injection of drilling fluids into the wellbore 18. A conductor 22 may provide structure for the wellbore 18 and may block collapse of the sides of the well 16 into the wellbore 18. A casing 24 may be disposed within the conductor 22. The casing 24 may provide structure for the wellbore 18 and may facilitate control of fluid and pressure during drilling of the well 16. The

wellhead assembly 12 may include a tubing spool, a casing spool, and a hanger (e.g., a tubing hanger or a casing hanger) to enable installation of the casing 24. As shown, the wellhead assembly 12 may include or be coupled to a blowout preventer (BOP) assembly 26, which may include one or more BOPs (e.g., one or more ram BOPs, one or more annular BOPs, or a combination thereof). For example, the BOP assembly 26 shown in FIG. 1 includes a ram BOP having moveable rams 28 configured to seal the wellbore 18.

**[0027]** A drilling riser 30 may extend between the BOP assembly 26 and a platform 32. The platform 32 may include various components that facilitate operation of the drilling system 10, such as pumps, tanks, and power equipment. The platform 32 may also include a derrick 34 that supports a tubular 36 (e.g., drill string), which may extend through the drilling riser 30. A drilling fluid system 38 may direct the drilling fluid into the tubular 36, and the drilling fluid may exit through one or more openings at a distal end portion 40 of the tubular 36 and may return (along with cuttings and/or other substances from the well 16) toward the platform 32 via an annular space (e.g., between the tubular 36 and the casing 24 that lines the wellbore 18; between the tubular 36 and the drilling riser 30). A drill bit 42 may be positioned at the distal end portion 40 of the tubular 36. The tubular 36 may rotate within the drilling riser 30 to rotate the drill bit 42, thereby enabling the drill bit 42 to drill and form the well 16.

**[0028]** As shown, the drilling system 10 may include a rotating control device (RCD) 44 that is configured to block fluid flow through the annular space that surrounds the tubular 36. For example, the RCD 44 may be configured to block the drilling fluid, cuttings, and/or other substances from passing across the RCD 44 from the well 16 toward the platform 32. The RCD 44 may be positioned at any suitable location within the drilling system 10, such as any suitable location between the wellbore 18 and the platform 32. For example, as shown, the RCD 44 may be positioned along the drilling riser 30 (e.g., in-line with the drilling riser 30) and between the BOP assembly 26 and the platform 32. In some embodiments, the RCD 44 may be positioned at or near a sea floor, mounted or fastened to the

BOP assembly 26 or other portion of the wellhead assembly 12, or other suitable location.

**[0029]** The RCD 44 and its components may be described with reference to the axial axis 2 (or axial direction), a radial axis 4 (or radial direction), and a circumferential axis 6 (or direction) to facilitate discussion. In operation, the tubular 36 may be rotated in the circumferential direction 6 and/or may be moved along the axial axis 2 to enable the drill bit 42 to drill the well 16. The RCD 44 and its components may provide the annular seal while the tubular 36 is stationary within the RCD 44, and also while the tubular 36 is rotated in the circumferential direction 6 and/or moved along the axial axis 2.

**[0030]** FIG. 2 is a cross-sectional side view of an embodiment of a seal assembly 50 (e.g., annular seal assembly) and a spool 52 (e.g., annular spool) that may be used in the RCD 44. The seal assembly 50 and the spool 52 may each be considered sub-assemblies that are configured to be coupled together to form the RCD 44. In particular, the seal assembly 50 is configured to be inserted into the spool 52 to form the RCD 44.

**[0031]** As shown, the seal assembly 50 may include an outer housing 54 (e.g., annular outer housing), an inner housing 56 (e.g., annular inner housing), a seal element 58 (e.g., annular seal element), one or more bearings 60 (e.g., annular bearing assemblies), a support plate 62 (e.g., annular support plate), a piston 64 (e.g., annular piston; first piston; seal assembly piston), a retaining ring 66 (e.g., annular retaining ring; stop ring), a cap ring 68 (e.g., annular cap ring), and one or more fasteners 70 (e.g., threaded fasteners, such as bolts) that couple the cap ring 68 to the outer housing 54. The outer housing 54 may be coupled to a base ring 72 (e.g., annular base ring), with a packer seal element 74 (e.g., annular seal element) supported between the outer housing 54 and the base ring 72. Certain groups of components may be referred to as assemblies (e.g., the outer housing 54, the inner housing 56, the cap ring 68, and/or the base ring 72 may be referred to herein as “a seal assembly housing”).

**[0032]** One or more additional internal seal elements 75 (e.g., annular internal seal elements; o-rings) may be provided between certain components of the seal assembly 50. The packer seal element 74 and/or the one or more additional internal seal elements 75 may be formed from an elastomer material and/or a metal material (e.g., metal or metal alloy material). Further, the seal element 58 may be formed from an elastomer material, and the support plate 62 may be formed from a metal material (e.g., metal or metal alloy material). In some embodiments, the support plate 62 includes protrusions 76 (e.g., annular protrusions) that extend into the seal element 58. In some embodiments, the protrusions 76 may be molded into the seal element 58.

**[0033]** Additionally, the seal element 58 includes a radially outer surface 78 (e.g., annular surface) that is configured to face away from a tubular when the tubular extends through the RCD 44 and a radially inner surface 80 that is configured to face toward the tubular when the tubular extends through the RCD 44. At least portions of the radially inner surface 80 are configured to contact and seal against the tubular when the tubular extends through the RCD 44.

**[0034]** The inner housing 56 defines a center bore 82 and a recess 84 (e.g., cavity). More particularly, the inner housing 56 defines a first orifice 86 (e.g., upper orifice; first orifice) at a first end 88 (e.g., upper end) of the center bore 82, and a radially inner wall 90 (e.g., annular wall) of the inner housing 56 defines the recess 84 with a curved dome shape. The seal element 58 and a portion of the support plate 62 are positioned within the recess 84 of the inner housing 56. More particularly, the radially outer surface 78 of the seal element 58 may face and contact the radially inner wall 90 of the inner housing 56.

**[0035]** As shown, the spool 52 may include a spool housing 100 (e.g., annular spool housing) with a flange 102 (e.g., annular flange) that is configured to couple to an adjacent structure or component (e.g., axially below the spool 52; via one or more fasteners, such as bolts; to part of the drilling riser 30 or the BOP assembly 26 of FIG. 1). The spool 52 may also include a spool piston 104 (e.g., annular piston; second piston) that is configured to move axially within a chamber 106 (e.g.,

annular chamber). The spool 52 may also include a spool retaining ring 108 (e.g., annular spool retaining ring), and one or more latches 110 (e.g., piston latches) that are configured to be placed within one or more openings 112 (e.g., radially extending through holes) formed in the spool housing 100. For example, multiple latches 110 may be placed within multiple openings 112 distributed circumferentially about the spool housing 100. One or more spool internal seal elements 114 (e.g., annular spool internal seal elements; o-rings) may be provided between certain components of the spool 52. The one or more spool internal seal elements 114 may be formed from an elastomer material and/or a metal material (e.g., metal or metal alloy material).

**[0036]** The spool 52 defines a spool recess 120 (e.g., spool cavity) that is configured to receive the seal assembly 50. For example, the one or more latches 110 may be retracted from the one or more openings 112 (e.g., withdrawn from the spool recess 120) to enable insertion or placement of the seal assembly 50 in the spool recess 120 (e.g., the seal assembly 50 is moved axially relative to the spool 52 to place the seal assembly 50 in the spool recess 120). Then, the one or more latches 110 may be inserted into the one or more openings 112 (e.g., extended into the spool recess 120) to hold the seal assembly 50 in the spool recess 120. In some embodiments, the one or more latches 110 may be electrically and/or mechanically actuated (e.g., via a hydraulic system). Further, the cap ring 68 of the seal assembly 50 and the one or more latches 110 of the spool 52 may include oppositely tapered surfaces 122, 124. The oppositely tapered surfaces 122, 124 may enable the one or more latches 110 to slide radially inwardly along the cap ring 68, and also drive the cap ring 68 axially to compress the seal assembly 50 between the one or more latches 110 and the spool housing 100 (e.g., a shoulder of the spool housing 100). Additional structural and operational features of the seal assembly 50 and the spool 52 are described with reference to FIGS. 3-7.

**[0037]** FIG. 3 is a cross-sectional side view of an embodiment of the seal assembly 50 positioned in the spool recess 120 of the spool 52 to form the RCD 44. Certain components labeled in FIG. 2 are also labeled in FIG. 3 to provide

context and to facilitate discussion. As shown, when the seal assembly 50 is positioned in the spool recess 120 of the spool 52, the spool housing 100 circumferentially surrounds the seal assembly 50. In particular, a radially outer wall 126 (e.g., annular wall) of the outer housing 54 of the seal assembly 50 may contact or be positioned against a radially inner wall 128 (e.g., annular wall) of the spool housing 100. Additionally, the cap ring 68 of the seal assembly 50 may contact or be engaged by the one or more latches 110, and the base ring 72 may contact or be landed on a shoulder 130 (e.g., annular shoulder) of the spool housing 100. As discussed herein, the one or more latches 110 may drive the cap ring 68 axially to compress the seal assembly 50 between the one or more latches 110 and the shoulder 130 of the spool housing 100. This may activate and compress the packer seal element 74 to form a packer annular seal between the outer housing 54 of the seal assembly 50 and the spool housing 100 of the spool 52. In any case, the seal assembly 50 is positioned and locked within the spool recess 120 of the spool 100 (e.g., blocked from moving axially relative to the spool 100; axially trapped between the one or more latches 110 and the shoulder 130 of the spool housing 100, and radially trapped within the radially inner wall 128 of the spool housing 100).

**[0038]** As shown, the seal assembly 50 and the spool 52 may be stacked or engaged to provide a continuous passage (e.g., center passage or bore) from a first end 132 (e.g., upper end) of the RCD 44 to a second end 134 (e.g., lower end) of the RCD 44. As discussed herein, the inner housing 56 includes the first orifice 86. In some embodiments, the first orifice 86 may define or set a respective inner diameter of the center bore 82 that forms part of the continuous passage across the RCD 44.

**[0039]** The piston 64 and the spool piston 104 may be part of a split piston actuation system 140 that operates to adjust the seal element 58 between a relaxed configuration (e.g., initial or first configuration; original state) and a compressed configuration (e.g., second configuration; deformed state). In the relaxed configuration, the seal element 58 may be withdrawn from the center bore 82 and/or may have a first inner diameter. In the compressed configuration, the

seal element 58 may extend into the bore 82 and/or may have a second inner diameter that is less than the first inner diameter. It should be appreciated that the split piston actuation system 140 may adjust the seal element 58 to the compressed configuration with various levels of compression. Thus, in the compressed configuration, the seal element 58 may have any of a variety of second inner diameters that are less than the first inner diameter.

**[0040]** In FIG. 3, the seal element 58 is in the relaxed configuration. To transition the seal element 58 to the compressed configuration, a fluid circuit 142 may provide a fluid to the chamber 106. In particular, the fluid circuit 142 may include a fluid source 144 and a fluid drain 146. A controller 150 (e.g., electronic controller) may control a first valve 152 to enable flow from the fluid source 144 to the chamber 106 and/or may control a second valve 154 to enable flow from the chamber 106 to the fluid drain 146. It should be appreciated that the fluid source 144 and the fluid drain 146 may be the same fluid tank and/or may be otherwise fluidly coupled to one another. Indeed, the fluid circuit 142 may have any suitable components or configuration that enable techniques disclosed herein (e.g., to drive movement of the spool piston 104). As described in more detail herein, such circulation of the fluid through the chamber 106 may adjust the seal element 58 relative to the inner housing 56 (and the tubular, when the tubular is within the RCD 44).

**[0041]** The controller 150 may control the delivery of the fluid from the fluid source 144 to the chamber 106 based on any of a variety of inputs, such as in response to an input received from a user interface device at the platform (e.g., from an operator) and/or in response to an input received from one or more sensors, such as one or more sensors that monitor one or more parameters indicative of the annular seal formed between the seal element 58 and the tubular, wellbore conditions, rotation of the tubular, or the like. For example, the controller 150 may receive an input that indicates an undesirable pressure below the RCD 44 (e.g., between the wellhead and the RCD 44) and/or above the RCD 44 (e.g., between the platform and the RCD 44) and may then adjust (e.g., increase) the fluid pressure in the chamber 106 to form and/or adjust (e.g., increase) the annular

seal (e.g., sealing force; radial force) between the seal element 58 and the tubular. As another example, the controller 150 may receive an input that indicates that the tubular will begin to move or is moving within the RCD 44 (e.g., rotating in the circumferential direction 6 and/or moving in the axial direction 2), and the controller 150 may then adjust (e.g., increase or decrease) the fluid pressure in the chamber 106 to thereby form and/or adjust (e.g., increase or decrease) the annular seal between the seal element 58 and the tubular. In this way, the RCD 44 may provide an adjustable and dynamic seal about the tubular (e.g., as the tubular rotates in the circumferential direction 6 and/or moves in the axial direction 2 through the RCD 44).

**[0042]** As shown in FIG. 3, the controller 150 includes a processor 156 and a memory device 158. It should be appreciated that the controller 150 may be a dedicated controller for the RCD 44 and/or the controller 150 may be part of or include a distributed controller with one or more electronic controllers in communication with one another to carry out the various techniques disclosed herein. The processor 156 may also include one or more processors configured to execute software, such as software for processing signals and/or controlling the components of the RCD 44. The memory device 158 disclosed herein may include one or more memory devices (e.g., a volatile memory, such as random access memory [RAM], and/or a nonvolatile memory, such as read-only memory [ROM]) that may store a variety of information and may be used for various purposes. For example, the memory device 158 may store processor-executable instructions (e.g., firmware or software) for the processor 156 to execute, such as instructions for processing signals and/or controlling the components of the RCD 44. It should be appreciated that the controller 150 may include various other components, such as a communication device that is capable of communicating data or other information (e.g., a current configuration of the RCD 44) to various other devices (e.g., a remote computing system or display system at the platform).

**[0043]** In operation, the fluid delivered from the fluid source 144 to the chamber 106 may exert a force on a surface 170 (e.g., axially facing surface) of the spool piston 104 to drive the spool piston 104 axially toward the piston 64. Eventually,

a contacting surface 172 (e.g., spool piston contacting surface; first contacting surface; axially facing surface) of the spool piston 104 contacts a contacting surface 174 (e.g., piston contacting surface; second contacting surface; axially facing surface) of the piston 64. Then, as the fluid continues to drive the spool piston 104, the spool piston 104 and the piston 64 move axially together.

**[0044]** Further, as the piston 64 moves axially through the outer housing 54 of the seal assembly 50, the piston 64 drives a thrust bearing 180 (e.g., one of the one or more bearings 60; annular bearing) and the support plate 62 axially toward the seal element 58. In turn, the support plate 62 contacts and drives the seal element 58 axially within the inner housing 56. As shown, the thrust bearing 180 is positioned axially between the piston 64 and the support plate 62, and the thrust bearing 180 contacts both the piston 64 and the support plate 62. Thus, the thrust bearing 180 is configured to transfer force (e.g., axial force) from the piston 64 to the support plate 62. The piston 64 may remain axially below the inner housing 56, while the thrust bearing 180 may extend axially into the inner housing 56 to drive the support plate 62 axially toward the seal element 58.

**[0045]** The curved dome shape of the radially inner wall 90 of the inner housing 56 blocks the seal element 58 from moving axially within the inner housing 56 and guides the seal element 58 into the center bore 82. Thus, as the support plate 62 drives the seal element 58 axially within the inner housing 56, the seal element 58 is compressed between the support plate 62 and the curved dome shape of the radially inner wall 90 of the inner housing 56, and the seal element 58 is also guided into the center bore 82. As shown, the support plate 62 may include the protrusions 76 that extend axially into the seal element 58 (e.g., insert into the seal element 58) to provide support and facilitate engagement with the seal element 58.

**[0046]** In operation, the tubular may extend through the RCD 44. Because the seal element 58 protrudes into the center bore 82 in the compressed configuration and/or because the inner diameter of the seal element 58 in the compressed configuration is less than an outer diameter of the tubular, the seal element 58 contacts and engages with the tubular. Further, the contact between the seal

element 58 and the tubular may cause the seal element 58 to form the annular seal about the tubular.

**[0047]** During drilling operations, the tubular may rotate in the circumferential direction 6 and/or move along the axial axis 2. In some embodiments, certain portions of the seal assembly 50 are supported on the one or more bearings 60, such as the thrust bearing 180 and one or more additional bearings 182 (e.g., bearing ring; annular bearing; cylindrical bearing), to rotate with the tubular (e.g., the rotation of the tubular drives the rotation of the certain portions of the seal assembly 50). For example, as shown, the rotation of the tubular may drive the rotation of the seal element 58, the support plate 62, and the inner housing 56 relative to the outer housing 54 (e.g., facilitated by the one or more bearings 60). It should be appreciated that the rotation of the tubular may drive the rotation of the seal element 58, the support plate 62, and the inner housing 56 relative to other components as well, such as relative to the piston 64, the cap ring 68, the base ring 72, the spool housing 100, the spool piston 104, the spool retaining ring 108, and so forth. Thus, certain components (e.g., the piston 64 and the spool piston 104) move only axially (e.g., without rotation), while other components (e.g., the seal element 58 and the support plate 62) move both axially and with rotation.

**[0048]** In this way, the tubular may not slip or rotate relative to the seal element 58, which may reduce wear on the seal element 58. In FIGS. 2 and 3, the thrust bearing 180 is positioned between the support plate 62 and the piston 64 along the axial axis 2, and the one or more additional bearings 182 are positioned between the inner housing 56 and the outer housing 54 along the radial axis 4. However, the one or more bearings 60 may be positioned at any suitable location to enable the rotation of the tubular to drive the rotation of the seal element 58.

**[0049]** It should be appreciated that the seal assembly 50 may be removed from the spool 52 via retracting the one or more latches 110 and then moving the seal assembly 50 axially relative to the spool 52 (e.g., lifting the seal assembly 50 out of the spool 52). Then, another seal assembly (e.g., having the same features as the seal assembly 50) may be inserted into the spool 52 and locked within the

spool via inserting the one or more latches 110. In this way, the disclosed embodiments facilitate replacement of the seal assembly 50 (e.g., from axially above the spool 52) without removal of the spool 52 from the adjacent structure or component (e.g., axially below the spool 52; from its position in line with the drilling riser 30 of FIG. 1 and/or the BOP assembly 26 of FIG. 1).

**[0050]** FIGS. 4-7 illustrate the seal element 58 in various configurations and during various operations. For example, FIG. 4 is a schematic cross-sectional side view of a portion of the seal element 58 in the relaxed configuration within the inner housing 56. As shown, in the relaxed configuration, the seal element 58 is withdrawn from the center bore 82 defined by the first orifice 86 of the inner housing 56 and/or the seal element 58 does not contact the tubular 36 in the center bore 82.

**[0051]** FIG. 5 is a schematic cross-sectional side view of the portion of the seal element 58 in the compressed configuration within the inner housing 56. As shown, in the compressed configuration, the seal element 58 extends into the center bore 82 defined by the first orifice 86 of the inner housing 56 and/or the seal element 58 contacts the tubular in the center bore 82. Further, the seal element 58 may have the first inner diameter in the relaxed configuration and the second inner diameter in the compressed configuration, wherein the first inner diameter is greater than the second inner diameter.

**[0052]** As described herein, the seal element 58 may be driven from the relaxed configuration of FIG. 4 to the compressed configuration of FIG. 5 via the split piston actuation system 140 of FIG. 3. In particular, the split piston actuation system 140 may drive the piston 64 shown in FIGS. 2 and 3 axially to compress the seal element 58 against the curved dome shape of the radially inner wall 90, which drives the seal element 58 into the center bore 82 and/or toward the tubular 36.

**[0053]** In FIG. 5, the seal element 58 is axially aligned with and sealed against a first portion 190 of the tubular 36. The first portion 190 of the tubular 36 may be a pipe section of a drill string, for example. FIG. 6 is a schematic cross-sectional side view of the portion of the seal element 58 in the compressed configuration

within the inner housing 56, wherein a portion of the seal element 58 is axially aligned with and sealed against a second portion 192 of the tubular 36. The second portion 192 of the tubular 36 may be a joint section of the drill string (e.g., the joint section that joins two pipe sections together), for example. The first portion 190 of the tubular 36 may have a first outer diameter, and the second portion 192 of the tubular 36 may be a radially expanded portion that has a second outer diameter greater than the first outer diameter. Accordingly, as the second portion 192 of the tubular 36 is inserted into the seal element 58, the seal element 58 compresses radially outwardly against the inner housing 56 to accommodate the second portion 192 of the tubular 36.

**[0054]** FIG. 7 is a schematic cross-sectional side view of the portion of the seal element 58 in the compressed configuration within the inner housing 56, wherein the seal element 58 is axially aligned with and sealed against the second portion 192 of the tubular 36 (e.g., along an entirety of an axial length of the seal element 58). It should be appreciated that as the tubular 36 moves axially through the RCD (e.g., into or out of the wellbore), the seal element 58 will continuously cycle between the configurations shown in FIGS. 5-7 to accommodate various portions of the tubular 36.

**[0055]** Thus, it should be appreciated that it may be desirable to perform maintenance operations to inspect and/or to replace the seal assembly 50 at certain times (e.g., after a particular number of hours in operation). As noted herein, the seal assembly 50 and the spool 52 enable efficient removal, installation, replacement, and/or other maintenance operations. Further, the split piston actuation system 140 may provide active control to provide a desirable level of sealing force exerted by the seal element 58 against the tubular 36, for example. In this way, the RCD 44 may have lower maintenance costs, more efficient maintenance operations, more reliable sealing, and so forth.

**[0056]** It should be appreciated that FIGS. 4-7 are intended to generally represent that at least some changes (e.g., deformation) occur between the relaxed configuration (FIG. 4) and the compressed configuration (FIGS. 5-7) of the

seal element 58. Indeed, the seal element 58 may not have the cross-sectional shapes shown in FIGS. 4-7, and these figures are merely intended to generally represent that the seal element 58 will deform in some way due to actuation of the split piston actuation system 140 and/or contact with the tubular 36.

**[0057]** Further, it should be appreciated that variations in form are envisioned. For example, FIG. 8 is a cross-sectional side view of an embodiment of a seal assembly 200 (e.g., annular seal assembly) and a spool 202 (e.g., annular spool) that may be used in the RCD 44. The seal assembly 200 and the spool 202 may each be considered sub-assemblies that are configured to be coupled together to form the RCD 44. In particular, the seal assembly 200 is configured to be inserted into the spool 202 to form the RCD 44.

**[0058]** As shown, the seal assembly 200 may include an outer housing 204 (e.g., annular outer housing), an inner housing 206 (e.g., annular inner housing; a two-part inner housing), a seal element 208 (e.g., annular seal element), one or more bearing assemblies 210 (e.g., annular bearing assemblies), a support plate 212 (e.g., annular support plate), a piston 214 (e.g., annular piston; first piston; seal assembly piston), a cap ring 218 (e.g., annular cap ring), and one or more fasteners 220 (e.g., threaded fasteners, such as bolts) that couple the cap ring 218 to the outer housing 204. The outer housing 204 may be coupled to a base ring 222 (e.g., annular base ring), with a packer seal element 224 (e.g., annular seal element) supported between the outer housing 204 and the base ring 222. One or more additional internal seal elements 225 (e.g., annular internal seal elements; o-rings) may be provided between certain components of the seal assembly 200.

**[0059]** The seal element 208 may include or be coupled to one or more inserts 226 (e.g., metal inserts). The one or more inserts 226 may be partially or entirely embedded within an elastomer body of the seal element 208 (e.g., positioned between a radially outer surface and a radially inner surface along the radial axis 4; covered by the elastomer body of the seal element 208; molded into the seal element 208). The one or more inserts 226 may be curved and extend axially through the seal element 208, as shown; however, the one or more inserts 226

have any suitable shape and/or configuration to provide support to the seal element 208.

**[0060]** The inner housing 206 defines a center bore 232 and a recess 234 (e.g., cavity). More particularly, the inner housing 206 defines a first orifice 236 (e.g., upper orifice; first orifice) at a first end 238 (e.g., upper end) of the center bore 232, and a radially inner wall 240 (e.g., annular wall) of the inner housing 206 defines the recess 234 with a curved dome shape. The seal element 208 is positioned within the recess 234 of the inner housing 206.

**[0061]** As shown, the spool 202 may include a spool housing 300 (e.g., annular spool housing) with a flange 302 (e.g., annular flange) that is configured to couple to an adjacent structure or component (e.g., axially below the spool 202; via one or more fasteners, such as bolts; to part of the drilling riser 30 or the BOP assembly 26 of FIG. 1). The spool 202 may also include a spool piston 304 (e.g., annular piston; second piston) that is configured to move axially within a chamber 306 (e.g., annular chamber). The spool 202 may also include spool retaining rings 308 (e.g., annular spool retaining rings), and one or more latches 310 (e.g., piston latches) that are configured to be placed within one or more openings 312 (e.g., radially extending through holes) formed in the spool housing 300. One or more spool internal seal elements (e.g., annular spool internal seal elements; o-rings) may be provided between certain components of the spool 202.

**[0062]** The spool 202 defines a spool recess 320 (e.g., spool cavity) that is configured to receive the seal assembly 200. For example, the one or more latches 310 may be retracted from the one or more openings 312 (e.g., withdrawn from the spool recess 320) to enable insertion or placement of the seal assembly 200 in the spool recess 320. Then, the one or more latches 310 may be inserted into the one or more openings 312 (e.g., extended into the spool recess 320) to hold the seal assembly 200 in the spool recess 320. In some embodiments, the one or more latches 310 may be electrically and/or mechanically actuated (e.g., via a hydraulic system). Further, the cap ring 218 of the seal assembly 200 and the one or more latches 310 of the spool 202 may include oppositely tapered surfaces 322,

324. The oppositely tapered surfaces 322, 324 may enable the one or more latches 310 to slide radially inwardly along the cap ring 218, and also drive the cap ring 218 axially to compress the seal assembly 200 between the one or more latches 310 and the spool housing 300 (e.g., a shoulder 330 of the spool housing 300).

**[0063]** The piston 214 and the spool piston 304 may be part of a split piston actuation system 340 that operates to adjust the seal element 208 between a relaxed configuration (e.g., initial or first configuration; original state) and a compressed configuration (e.g., second configuration; deformed state). In FIG. 8, the seal element 208 is in the relaxed configuration. To transition the seal element 208 to the compressed configuration, a fluid circuit may provide a fluid to the chamber 306. As described in more detail herein, such circulation of the fluid through the chamber 306 may adjust the seal element 208 relative to the inner housing 206 (and the tubular, when the tubular is within the RCD 44).

**[0064]** For example, the fluid delivered to the chamber 306 may exert a force on the spool piston 304 to drive the spool piston 304 axially toward the piston 214. The spool piston 304 contacts the piston 214, and the spool piston 304 and the piston 214 move axially together. In turn, the piston 214 drives a thrust bearing 380 (e.g., one of the one or more bearings 60; annular bearing) and the support plate 212 axially toward the seal element 208. Then, the support plate 212 contacts and drives the seal element 208 axially within the inner housing 206.

**[0065]** The curved dome shape of the inner housing 206 blocks the seal element 208 from moving axially within the inner housing 206 and guides the seal element 208 into the center bore 232. Thus, as the support plate 212 drives the seal element 208 axially within the inner housing 206, the seal element 208 is compressed between the support plate 212 and the curved dome shape of the inner housing 206, and the seal element 208 is also guided into the center bore 232. As shown, the support plate 212 may include a stepped configuration (e.g., portions separated along the axial axis 2) and/or at least one portion with a flat

surface (e.g., in a plane that contains the radial axis 4) that contacts the seal element 208, although other configurations (e.g., protrusions) are envisioned.

**[0066]** In operation, the tubular may extend through the RCD 44. Because the seal element 208 protrudes into the center bore 232 in the compressed configuration and/or because the inner diameter of the seal element 208 in the compressed configuration is less than an outer diameter of the tubular, the seal element 208 contacts and engages with the tubular. Further, the contact between the seal element 208 and the tubular may cause the seal element 208 to form the annular seal about the tubular. During drilling operations, the tubular may rotate in the circumferential direction 6 and/or move along the axial axis 2. In some embodiments, certain portions of the seal assembly 200 are supported on the one or more bearings 60, such as the thrust bearing 380 and one or more additional bearings 382 (e.g., bearing ring; annular bearing; cylindrical bearing), to rotate with the tubular (e.g., the rotation of the tubular drives the rotation of the certain portions of the seal assembly 200).

**[0067]** It should be appreciated that the seal assembly 200 may be removed from the spool 202 via retracting the one or more latches 310 and then moving the seal assembly 200 axially relative to the spool 202 (e.g., lifting the seal assembly 200 out of the spool 202). Then, another seal assembly (e.g., having the same features as the seal assembly 200) may be inserted into the spool 202 and locked within the spool via inserting the one or more latches 310. In this way, the disclosed embodiments facilitate replacement of the seal assembly 200 (e.g., from axially above the spool 202) without removal of the spool 202 from the adjacent structure or component (e.g., axially below the spool 202; from its position in line with the drilling riser 30 of FIG. 1 and/or the BOP assembly 26 of FIG. 1). The seal element 208 may deform in a similar manner as represented in FIGS. 4-7.

**[0068]** Additionally, the seal assembly 200 may include any of the features of the seal assembly 50 (or vice versa), and the spool assembly 202 may include any of the features of the spool assembly 52 (or vice versa). Thus, any of the features disclosed herein may be combined in any suitable manner. Further, as

demonstrated in at least FIGS. 2, 3, and 8, the present embodiments may include a seal assembly with any of a variety of shapes and features. For example, the seal element may include a relatively axially elongated shape, as shown in FIGS. 2 and 3, or a relatively axially compressed shape, as shown in FIG. 8. Additionally, the seal element may include the inserts (e.g., molded into the elastomer of the seal element). Alternatively, the seal element may be devoid of the inserts (e.g., only elastomer material). Similarly, the support plate may include a flat surface(s) and/or protrusions that extend to engage the seal element. Further, the pistons and related components of the split piston actuation system may have any of a variety of shapes and features. For example, the piston and/or the spool piston may have complex shapes, as shown in FIGS. 2 and 3, or may be cylindrical, as shown in FIG. 8.

**[0069]** While the disclosure may be susceptible to various modifications and alternative forms, specific embodiments have been shown by way of example in the drawings and have been described in detail herein. However, it should be understood that the disclosure is not intended to be limited to the particular forms disclosed. Rather, the disclosure is intended to cover all modifications, equivalents, and alternatives falling within the spirit and scope of the disclosure as defined by the following appended claims.

**CLAIMS**

1. A rotating control device (RCD) for a drilling system, the rotating control device comprising:
  - a seal assembly comprising:
    - a seal assembly housing;
    - a seal element positioned within the seal assembly housing; and
    - a piston positioned within the seal assembly housing, wherein the piston is configured to drive the seal element axially within the seal assembly housing to enable the seal element to form an annular seal about a tubular as the tubular rotates, moves axially, or both.
2. The RCD of claim 1, further comprising a spool, wherein the spool comprises a spool housing configured to receive the seal assembly.
3. The RCD of claim 2, wherein the spool comprises a spool piston that is configured to move axially within the spool housing, and the spool piston is configured to engage the piston when the seal assembly is positioned in the spool housing.
4. The RCD of claim 3, wherein the spool piston is configured to drive the piston axially within the seal assembly housing to cause the piston to drive the seal element axially within the seal assembly housing.
5. The RCD of claim 3, wherein the spool piston is supported in a chamber of the spool housing, and the spool comprises or is coupled to a fluid circuit that is configured to provide a fluid into the chamber to move the spool piston axially within the spool housing.
6. The RCD of claim 2, wherein the spool comprises one or more latches configured to lock the seal assembly within the spool housing.

7. The RCD of claim 6, wherein the one or more latches are hydraulically actuated.
8. The RCD of claim 6, wherein the one or more latches are configured to engage the seal assembly housing to axially compress the seal assembly housing between the spool housing and the one or more latches.
9. The RCD of claim 1, wherein the seal assembly comprises a support plate positioned axially between the seal element and the piston.
10. The RCD of claim 9, wherein the seal assembly comprises a bearing positioned axially between the piston and the support plate to enable the support plate and the seal element to rotate relative to the piston.
11. The RCD of claim 1, wherein the seal assembly housing comprises an outer housing and an inner housing supported within the outer housing, the seal element is positioned within the inner housing, and the seal assembly comprises one or more bearings that enable the seal element and the inner housing to rotate relative to the outer housing.
12. The RCD of claim 11, wherein the inner housing defines a seal element recess comprising a curved dome shape, and the seal element is positioned within the seal element recess.
13. A rotating control device (RCD) for a drilling system, the RCD comprising:
  - a seal assembly comprising:
    - a seal assembly housing;
    - a seal element positioned within the seal assembly housing; and
    - a piston positioned within the seal assembly housing; and
  - a spool comprising:

a spool housing that defines a spool recess configured to receive the seal assembly; and

a spool piston that is configured to move within the spool housing, wherein the spool piston is configured to contact and drive the piston toward the seal element to cause the seal element to form an annular seal about a tubular when the seal assembly is positioned in the spool recess.

14. The RCD of claim 13, wherein the spool piston and the piston are configured to move axially without rotation, and the seal element is configured to move axially with rotation.

15. The RCD of claim 13, further comprising one or more bearings configured to facilitate rotation of the seal element relative to the seal assembly housing.

16. The RCD of claim 13, wherein the spool housing comprises a flange to enable the spool housing to be coupled in line with a drilling riser, a blowout preventer assembly, or both.

17. The RCD of claim 13, wherein the spool comprises one or more latches configured to lock the seal assembly within the spool housing.

18. The RCD of claim 13, wherein the seal assembly housing defines a seal element recess comprising a curved dome shape, and the seal element is positioned in the seal element recess.

19. A method of operating a drilling system, the method comprising:  
fastening a spool to a component of the drilling system;  
placing a seal assembly into the spool to form a rotating control device (RCD);  
actuating a split piston system comprising a spool piston supported in a chamber of the spool and a piston supported in a seal assembly housing of the

seal assembly to compress a seal element of the seal assembly to form an annular seal about a tubular; and

rotating the tubular, moving the tubular axially, or both while the seal element forms the annular seal about the tubular.

20. The method of claim 19, further comprising removing the seal assembly from the spool and placing another seal assembly into the spool without removing the spool from the component of the drilling system.

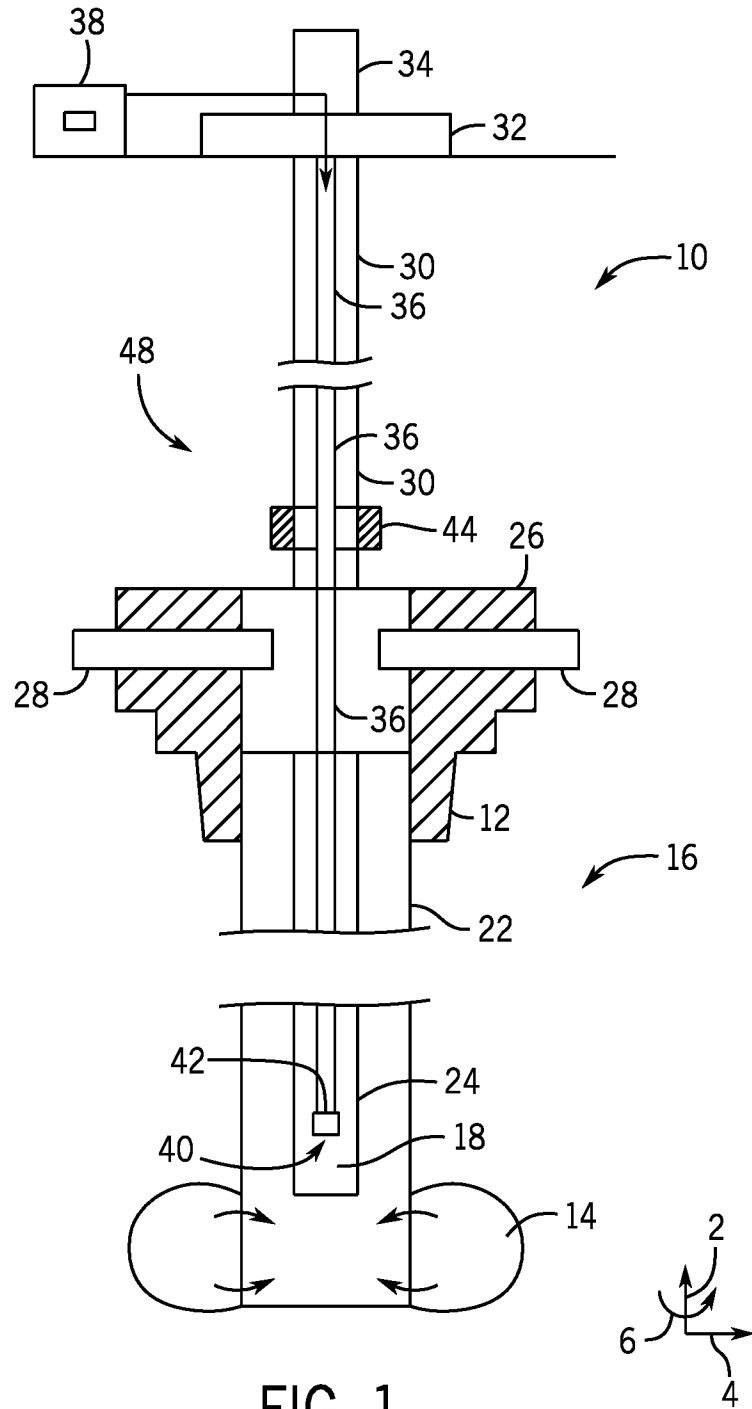

FIG. 1

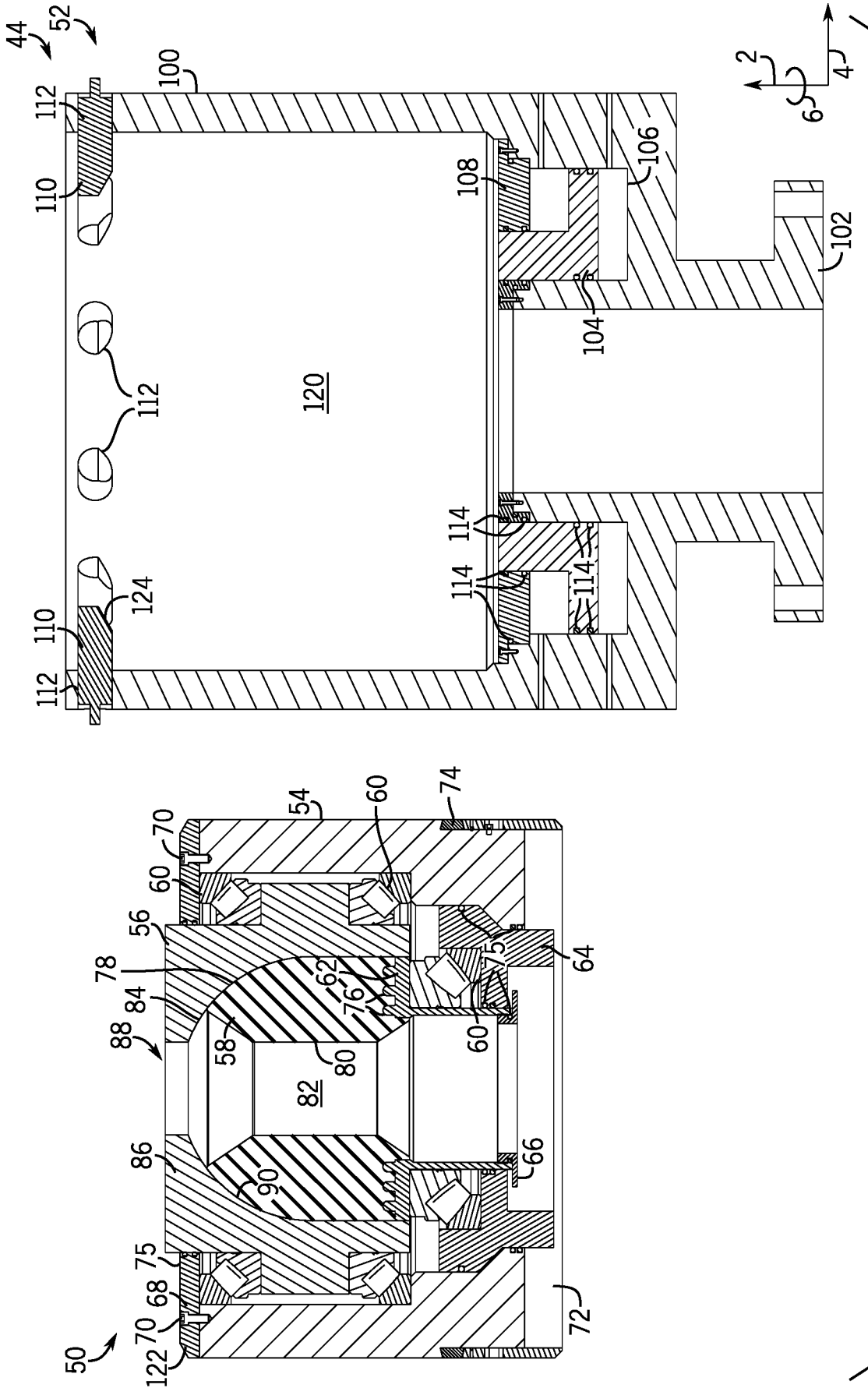

FIG. 2

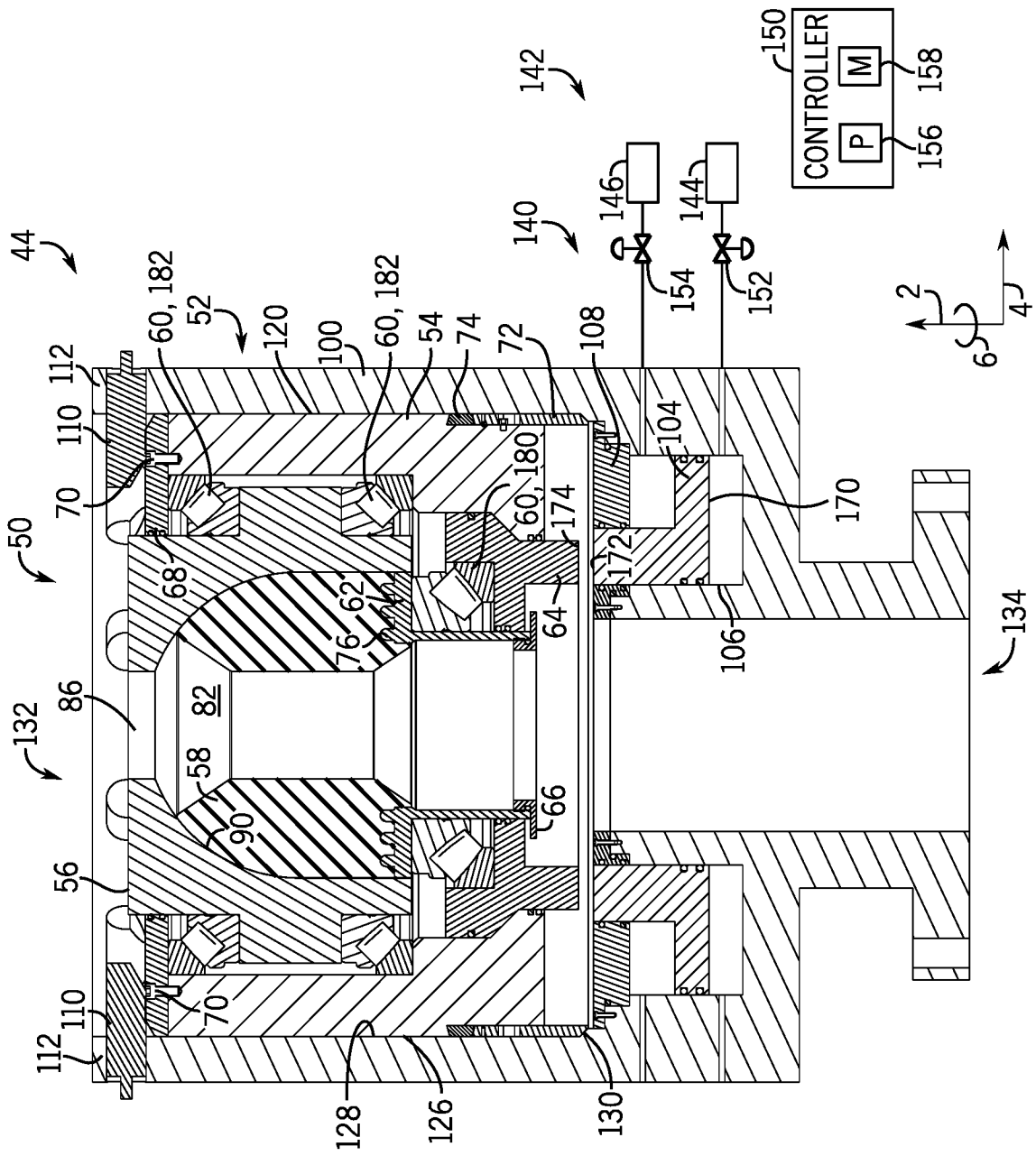

FIG. 3

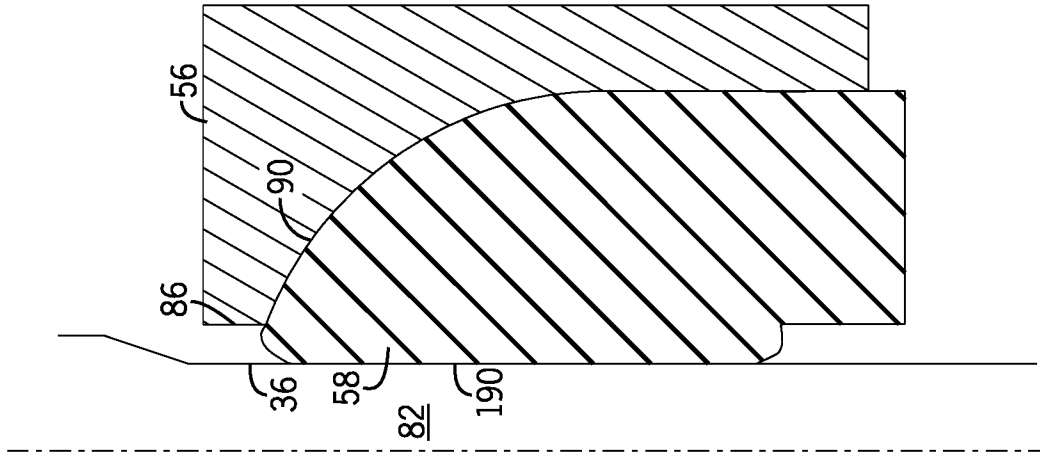

FIG. 5

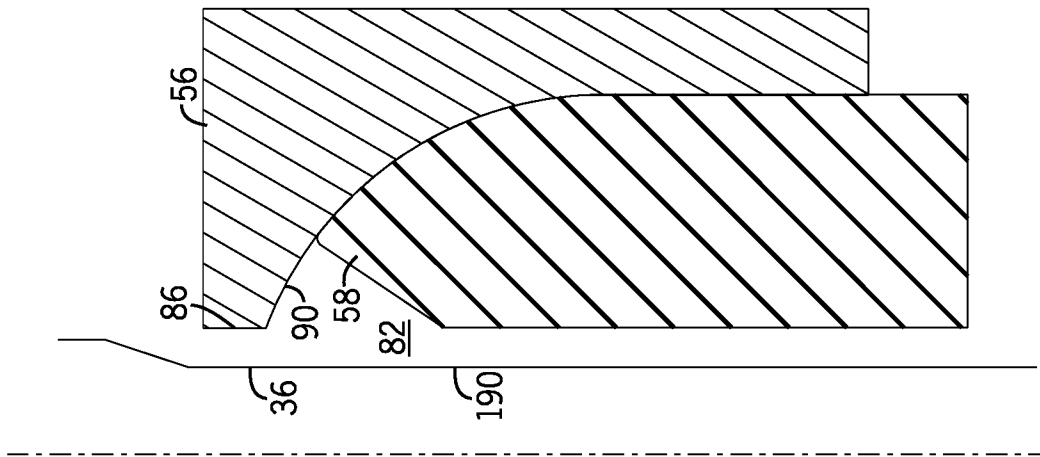

FIG. 4

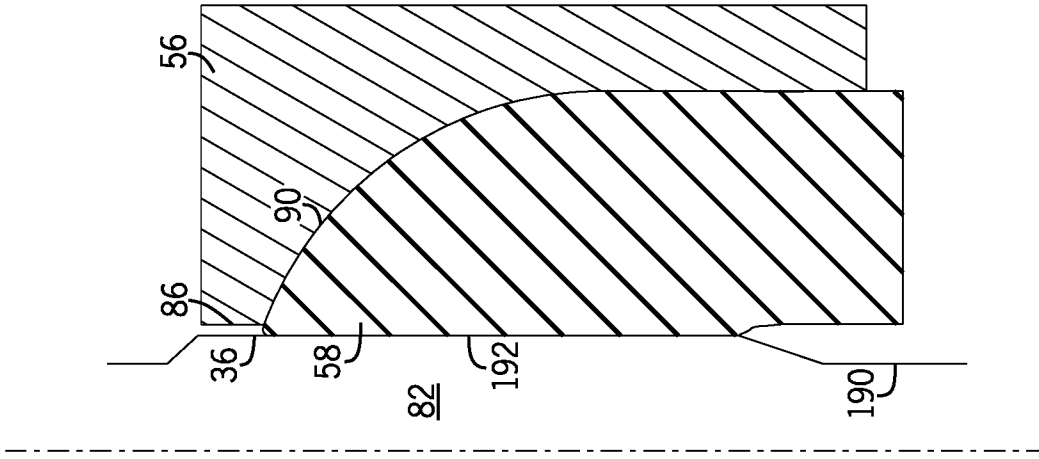

FIG. 7

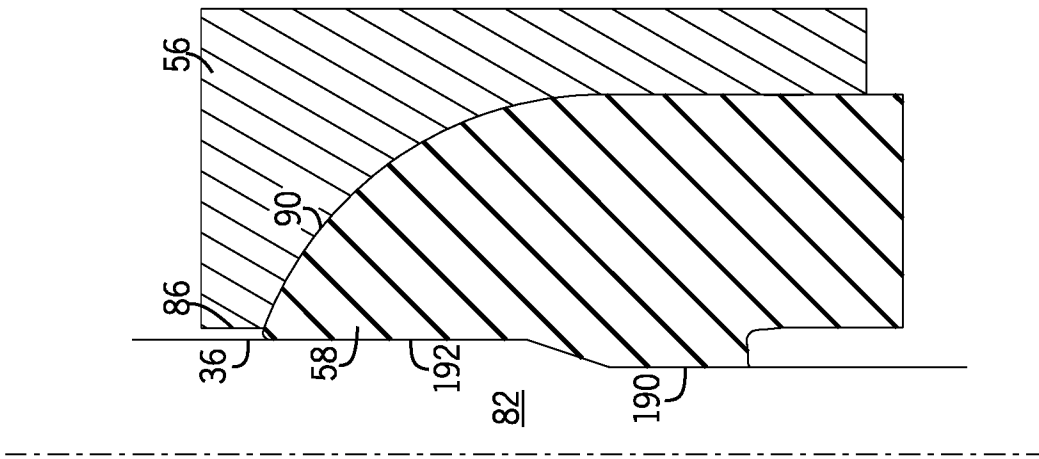

FIG. 6

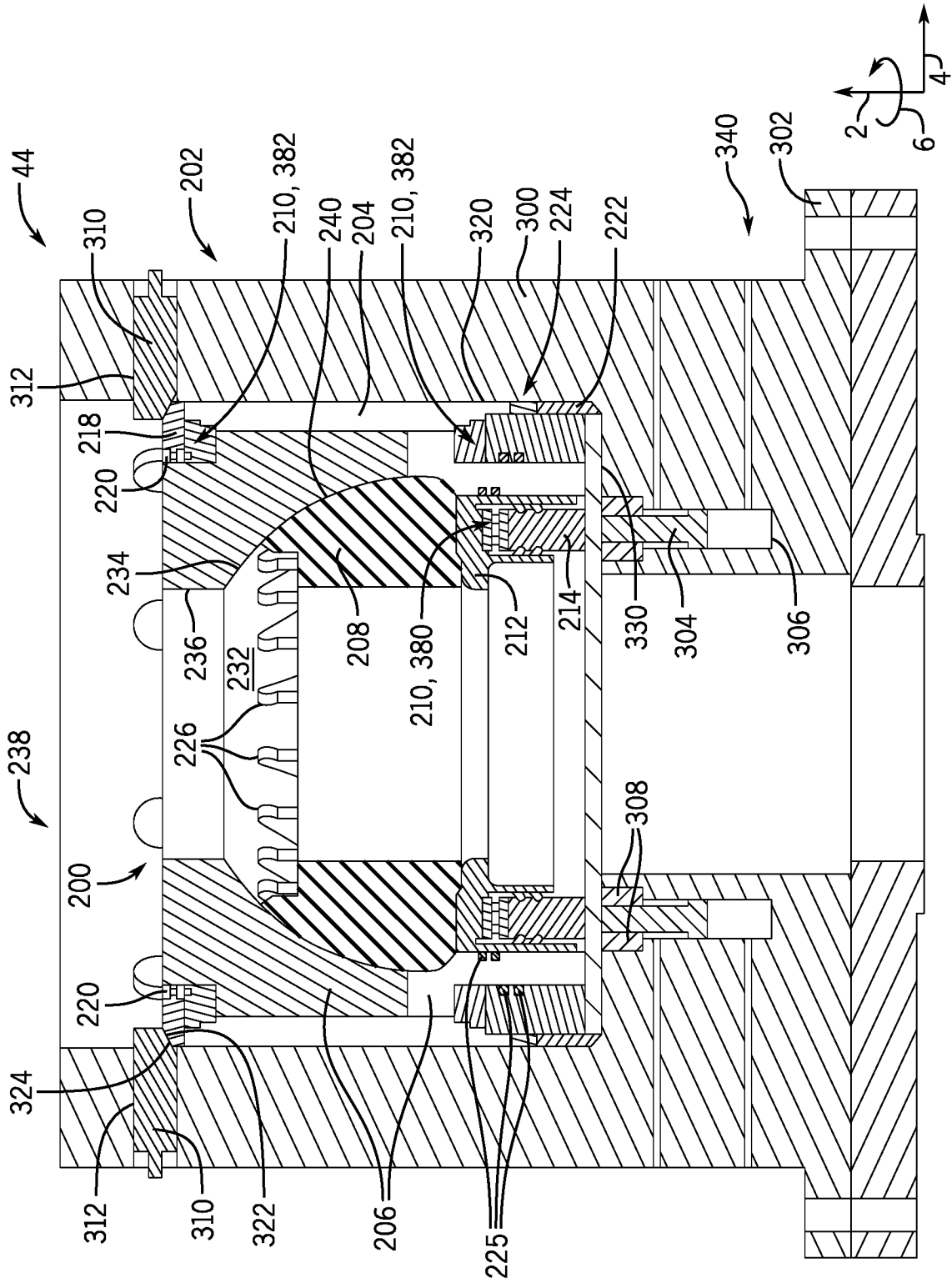

FIG. 8