



INTERNATIONAL APPLICATION PUBLISHED UNDER THE PATENT COOPERATION TREATY (PCT)

<p>(51) International Patent Classification ⁵ : G01N 33/58, 33/557</p>	<p>A1</p>	<p>(11) International Publication Number: WO 94/12882 (43) International Publication Date: 9 June 1994 (09.06.94)</p>
<p>(21) International Application Number: PCT/US92/10072 (22) International Filing Date: 24 November 1992 (24.11.92) (71) Applicant: OMNIGENE, INC. [US/US]; 763-D Concord Avenue, Cambridge, MA 02138 (US). (72) Inventors: BACKMAN, Keith, C.; 2000 Carlisle Road, Bedford, MA 01730 (US). MUNKHOLM, Christiane; 12 Gifford Court, Salem, MA 01970 (US). (74) Agents: REYNOLDS, Leo, R. et al.; Hamilton, Brook, Smith & Reynolds, Two Militia Drive, Lexington, MA 02173 (US).</p>	<p>(81) Designated States: AT, AU, BB, BG, BR, CA, CH, CS, DE, DK, ES, FI, GB, HU, JP, KP, KR, LK, LU, MG, MN, MW, NL, NO, PL, RO, RU, SD, SE, European patent (AT, BE, CH, DE, DK, ES, FR, GB, GR, IE, IT, LU, MC, NL, PT, SE), OAPI patent (BF, BJ, CF, CG, CI, CM, GA, GN, ML, MR, SN, TD, TG).</p> <p>Published <i>With international search report.</i></p>	
<p>(54) Title: LIGAND ASSAY USING INTERFERENCE MODULATION</p>		
<p>(57) Abstract</p> <p>An optical detection method for detecting specific ligands in an immunoassay is formed by diffracting a beam of light through slits formed in a mask and thereby forming an interference pattern. The diffracted light of one of the slits is disturbed by an assay having a ligand which when reacted with anti-ligand changes the optical characteristics of the assay thereby changing the interference pattern in a concentration dependent manner.</p>		

FOR THE PURPOSES OF INFORMATION ONLY

Codes used to identify States party to the PCT on the front pages of pamphlets publishing international applications under the PCT.

AT	Austria	GB	United Kingdom	MR	Mauritania
AU	Australia	GE	Georgia	MW	Malawi
BB	Barbados	GN	Guinea	NE	Niger
BE	Belgium	GR	Greece	NL	Netherlands
BF	Burkina Faso	HU	Hungary	NO	Norway
BG	Bulgaria	IE	Ireland	NZ	New Zealand
BJ	Benin	IT	Italy	PL	Poland
BR	Brazil	JP	Japan	PT	Portugal
BY	Belarus	KE	Kenya	RO	Romania
CA	Canada	KG	Kyrgyzstan	RU	Russian Federation
CF	Central African Republic	KP	Democratic People's Republic of Korea	SD	Sudan
CG	Congo	KR	Republic of Korea	SE	Sweden
CH	Switzerland	KZ	Kazakhstan	SI	Slovenia
CI	Côte d'Ivoire	LI	Liechtenstein	SK	Slovakia
CM	Cameroon	LK	Sri Lanka	SN	Senegal
CN	China	LU	Luxembourg	TD	Chad
CS	Czechoslovakia	LV	Latvia	TG	Togo
CZ	Czech Republic	MC	Monaco	TJ	Tajikistan
DE	Germany	MD	Republic of Moldova	TT	Trinidad and Tobago
DK	Denmark	MG	Madagascar	UA	Ukraine
ES	Spain	ML	Mali	US	United States of America
FI	Finland	MN	Mongolia	UZ	Uzbekistan
FR	France			VN	Viet Nam
GA	Gabon				

-1-

LIGAND ASSAY USING INTERFERENCE MODULATIONBackground of the Invention

It is desirable in certain circumstances to measure very low concentrations of certain organic compounds. In medicine, for example, it is very useful to determine the concentration of a given kind of molecule, usually in solution, which either exists naturally in physiological fluids (e.g. blood or urine) or which has been introduced into the living system (e.g. drugs or contaminants). Because of the rapidly advancing state of understanding of the molecular basis of both the normal and diseased states of living systems, there is an increasing need for methods of detection which are quantitative, specific to the molecule of interest, highly sensitive and relatively simple to implement. Examples of molecules of interest in a medical and/or biological context include, but are not limited to, drugs, sex and adrenal hormones, biologically active peptides, circulating hormones and antigens associated with tumors or infectious agents. In the case of drugs, for example, the safe and efficacious use of a particular drug requires that its concentration in the circulatory system be held to within relatively narrow bounds, referred to as the therapeutic range.

One broad approach used to detect the presence of a particular compound, referred to as the analyte, is the immunoassay, in which detection of a given molecular species, referred to generally as the ligand, is accomplished through the use of a second molecular species, often called the antiligand, or the receptor,

-2-

which specifically binds to the first compound of interest. The presence of the ligand of interest is detected by measuring, or inferring, either directly or indirectly, the extent of binding of ligand to
5 antiligand. The ligand may be either monoepitopic or poly epitopic and is generally defined to be any organic molecule for which there exists another molecule (i.e. the antiligand) which specifically bonds to said ligand, owing to the recognition of some
10 portion of said ligand. Examples of ligands include macromolecular antigens and haptens (e.g. drugs). The antiligand, or receptor, is usually an antibody, which either exists naturally or can be prepared
15 artificially. The ligand and antiligand together form a homologous pair. Throughout the text the terms antigen and antibody, which represent typical examples, are used interchangeably with the terms ligand and antiligand, respectively, but such usage does not signify any loss of generality. In some cases, the
20 antibody would be the ligand and the antigen the antiligand, if the presence of the antibody is to be detected.

Implementation of a successful immunoassay requires a detectable signal which is related to the
25 extent of antigen-antibody binding which occurs upon the reaction of the analyte with various assay reagents. Usually that signal is provided for by a label which is conjugated to either the ligand or the antiligand, depending on the mode of operation of the
30 immunoassay. Any label which provides a stable, conveniently detectable signal is an acceptable candidate. Physical or chemical effects which produce detectable signals, and for which suitable labels

-3-

exist, include radioactivity, fluorescence, chemiluminescence, phosphorescence and enzymatic activity, to name a few.

Broadly speaking, immunoassays fall into two
5 general categories - heterogeneous and homogeneous. In heterogeneous assays, the purpose of the label is simply to establish the location of the molecule to which it conjugates - i.e. to establish whether the labeled molecule is free in solution or is part of a
10 bound complex. Heterogeneous assays generally function by explicitly separating bound antigen-antibody complexes from the remaining free antigen and/or antibody. A method which is frequently employed consists of attaching one of the members of the
15 homologous pair to a solid surface by covalent binding, physical absorption, or some other means. When antigen-antibody binding occurs, the resulting bound complexes remain attached to this solid surface (composed of any suitable inert material such as
20 plastic, paper, glass, metal, polymer gel, etc.), allowing for separation of free antigen and/or antibody in the surrounding solution by a wash step. A variation on this method consists of using small (typically 0.05 to 20 microns) suspendable particles to
25 provide the solid surface onto which either antigen or antibody is immobilized. Separation is effected by centrifugation of the solution of sample, reagents and suspendable beads at an appropriate speed, resulting in selective sedimentation of the support particles
30 together with the bound complexes.

In the homogeneous assay, the signal obtained from the labeled ligand or antiligand is modified, or modulated, in some systematic, recognizable way when

-4-

ligand-antiligand binding occurs. Consequently, separation of the labeled bound complexes from the free labeled molecules is no longer required.

There exist a number of ways in which immunoassays
5 can be carried out.

In the competitive mode, the analyte, assumed to be antigen, is allowed to compete with a known concentration of labeled antigen (provided in reagent form in the assay kit) for binding to a limited number
10 of antibody molecules which are attached to a solid matrix. Following an appropriate incubation period, the reacting solution is washed away, ideally leaving just labeled antigen-antibody complexes attached to the binding surface, thereby permitting the signal from the
15 labels to be quantitated.

In another method, called the sandwich mode, the analyte, again assumed to be antigen, reacts with an excess of surface-immobilized antibody molecules. After a suitable incubation period, an excess of label-
20 conjugated antibody is added to the system to react with another bonding site on the antigen. After this reaction has gone to essential completion, a wash step removes unbound labeled antibody and other sources of contamination, permitting measurement of the signal
25 produced by labels which are attached to antibody-antigen-antibody complexes. Any non-specific bonding of the labeled antibody to the surface will, however, contribute to the signal.

In yet another approach, called the indirect mode,
30 the analyte, this time assumed to consist of specific antibody, is allowed to bind to surface-immobilized antigen which is in excess. The binding surface is then washed and allowed to react with label-conjugated

-5-

antibody. After a suitable incubation period the surface is washed again, removing free labeled antibody and permitting measurement of the signal due to bound labeled antibody. The resulting signal strength varies
5 inversely with the concentration of the starting (unknown) antibody, since labeled antibody can bind only to those immobilized antigen molecules which have not already complexed to the analyte.

One of the most sensitive immunoassays developed
10 thusfar is the radioimmunoassay (RIA), in which the label is a radionuclide, such as I^{125} , conjugated to either member of the homologous (binding) pair.

Fluorescence provides a potentially attractive alternative to radioactivity as a suitable label for
15 immunoassays. For example, fluorescein (usually in the form of fluorescein isothiocyanate, or "FITC") and a variety of other fluorescent dye molecules can be attached to most ligands and receptors without significantly impairing their binding properties.
20 Fluorescent molecules have the property that they absorb light over a certain range of wavelengths and (after a delay ranging form 10^{-9} to 10^{-4} seconds) emit light over a range of longer wavelengths. Hence, through the use of a suitable light source, detector
25 and optics, including excitation and emission filters, the fluorescence intensity originating from labeled molecules can be determined.

Use of an enzyme as a label has produced a variety of useful enzyme immunoassays (EIA), the most popular
30 of which is known as ELISA. In the typical heterogeneous format a sandwich-type reaction is employed, in which the ligand of interest, assumed here

-6-

to be antigen, binds to surface-immobilized specific antibody and then to an enzyme-antibody conjugate. After suitable incubation, any remaining free enzyme conjugate is eliminated by a wash or centrifugation
5 step. A suitable substrate for the enzyme is then brought into contact with the surface containing the bound complexes. The enzyme-substrate pair is chosen to provide a reaction product which yields a readily detectable signal, such as a color change or a
10 fluorescence emission. The use of an enzyme as a label serves to effectively amplify the contribution of a single labeled bound complex to the measured signal, because many substrate molecules can be converted by a single enzyme molecule.

15 As may be seen from the above background summary many of the immunoassay techniques rely on optical methods to detect specific ligands in a sample matrix and it may be said that these techniques have fallen generally into three optical classes:

- 20 1) Methods based on the molecular absorbance of light, which comprise all standard spectroscopic methods such as absorbance, fluorescence, phosphorescence, fluorescence polarization, circular dichroism, Raman, and infrared spectroscopies;
- 25 2) Methods based on the generation of light by a chemical reaction, which is known as chemiluminescence, or bioluminescence when the reaction is catalyzed by an enzyme; and
- 30 3) Methods based on the change in the direction of propagation of a lightwave such as refractometry, optical rotary dispersion, and methods based on the scattering of light.

With all of the above the signal is collected and

-7-

measured by a detection apparatus which monitors the phenomenon as it occurs within the sample's molecular population. The measurement is a function of the intensity or degree of change occurring within the sample. Although most of these methods produce isotropic signals, even the anisotropic methods such as fluorescence polarization, produce signals which are fundamentally measured as intensities.

Emerging now are optical detection techniques which may comprise a new and fourth class of optical methods based on spatial patterns produced by the interaction of radiation with the ligand or anti-ligand. In this class of optical detection techniques the optical signal is collected outside of the sample, as a pattern or an intensity measured at more than one geometrically defined spatial position. The following descriptions are representative of this new class of optical detection methods.

Nicoli in U.S. Patent No. 4,647,544 issued 3 March 1987 entitled "Immunoassay Using Optical Interference Detection" describes optical detection of a binding reaction between a ligand and an antiligand wherein a pattern is formed on a substrate by a spatial array of microscopic dimensions of antiligand material immobilized to a substrate. Upon exposure to the sample the ligand binds to the substrate to form a physical pattern. A source of optical radiation is directed to the pattern at a particular incidence angle to produce an optical interference pattern in accordance with the binding reaction and with a strong scattering intensity at one or more Bragg scattering angles. An optical detector is located relative to the pattern and aligned with the Bragg scattering angle to

-8-

detect the strong scattering intensity and produce a signal representative of the binding reaction.

Another patent, "Diffraction Immunoassay and Reagents" EPO 0276968 published 3 August 1988 describes
5 a "biograting" based assay in which a biological diffraction grating consisting of lines of active binding reagent is formed on a silicon substrate surface. After contacting the assay surface with the sample and separating the sample from the assay, the
10 surface is illuminated and the binding of analyte to surface in a uniform manner generates a diffraction pattern. An optical detector, or array of detectors, positioned at predetermined angles is used to measure the diffracted light.

15 PCT Application No. PCT/GB85/00427 describes the use of fluorescently tagged molecules binding to a substrate pattern so that the fluorescence emission is organized into a narrow cone of angles instead of being uniform in all directions.

20 In each of these examples the detected signal is produced by light interacting with analytes that have been entrapped on a surface in a geometric manner, and the detectable signal is characterized by both amplitude and pattern formation.

25 These spatial based optical detection immunoassay methods are controlled by the spatial geometry, formed by either the ligand or antiligand, which must be of extremely fine detail and small dimensions; sophisticated immobilization technology will be
30 required which may be difficult to reproducibly implement for many useful ligands or antiligands.

Summary of the Invention

-9-

The invention comprises a method of modulating an interference pattern created by interference between two or more light beams by reacting a ligand with an antiligand in an assay to cause a change in the optical characteristics of the assay. This change in optical characteristics is used to disturb the interference pattern by placing the reacted assay in the path of one or more of the light beams creating the interference pattern. The resultant change in the interference pattern is dependent on the concentration of the ligand and can be used to detect the presence of the ligand and its concentration in the assay.

In a first embodiment, an interference pattern is formed by projecting light through a mask having at least two narrow parallel slits, having a width which can be very small but remains larger than the wavelength of the source light, and separated by a distance which exceeds the slit width. The light is thereby diffracted into two or more light beams which interfere and form an interference pattern, which may, for example, be visualized by projection on a screen. One or more of the slits may then be blocked to product a different interference pattern. An assay surface with a ligand which when reacted with an anti-ligand reduces the transparency of the assay surface is then placed on or over a slit or slits, causing the interference pattern to change to a pattern which is intermediate between the standard pattern formed by the uncovered multi-slit and the standard pattern formed when the slit or slits relevant to the assay surface are completely obscured. The change in the interference pattern compared to the standard is measured and related to the concentration of the assay

-10-

ligand.

Preferably a source of monochromatic light, such as a laser, is used to project light through multi-slit openings formed on a foil mask. An assay slide is
5 mounted adjacent to the foil to obstruct one or more slits.

A lens may be used to magnify the interference pattern so that it can be projected onto a screen and photographed. The resultant photographs are then
10 analyzed by a densitometer to determine the intensity of the light at certain points on the pattern before and after the slit is covered, thereby to determine the presence of the ligand and its concentration in the assay.

15 Alternatively, the intensity of the pattern can be analyzed in real time using an array of pixels formed by photodetectors to form electrical signals corresponding to each pixel and processing these signals in a computer.

20 Brief Description of the Drawings

Fig. 1 is a diagram of light interference produced by a two-slit mask to illustrate the theory behind the invention.

Fig. 2 is a diagram illustrating in curve (a) the
25 diffraction pattern when only one slit (S_1) is open and in curve (b) the interference pattern when both slits (S_1 & S_2) are open.

Fig. 3 is a schematic diagram of a preferred embodiment of the invention.

30 Fig. 4 is a flow chart of the important steps in forming a colloidal gold-labeled antibody (Au-antibody)

-11-

sandwich assay for use in the apparatus of the invention.

Fig. 5 is a plot of the intensity of two adjacent maxima of double-slit interference pattern showing the change caused by varying the transmission through one slit.

Fig. 6 are plots of intensity I versus transmission T for changes in I_{\max} (curve ΔI_{\max}) and changes in transmission (curve ΔT).

Fig. 7(a) is a plot of the visibility V_2 of the fringe pattern as a function of the percent of transmission ($I_2\%$) through the second slit S_2 .

Fig. 7(b) is a plot of the $-\log V_2 \times 1,000$ versus $\Delta\% I_2$.

Fig. 8 is a plot of the change in I_{\max} and I_{\min} as a function of change in transmission I_2 through slit S_2 .

Fig. 9a-9d is a schematic flow diagram of an alternate embodiment of the invention.

Fig. 10 is a schematic of yet another alternate embodiment.

Fig. 11 is a schematic of an alternate embodiment in which the double-slit pattern is produced by a virtual slit S_2 and an actual slit S_1 and a mirror M .

Fig. 12 is a schematic of a Fresnel's mirror embodiment of the invention.

Fig. 13 is a schematic of a bi-prism embodiment of the invention.

Fig. 14 is a schematic of a Billet's split lens embodiment of the invention.

Fig. 15 is a schematic of a flow cell embodiment.

Fig. 16 is a schematic of an alternate flow cell embodiment.

-12-

Fig. 17 is a schematic illustrating an alternate embodiment wherein N slits are formed and N-X slits covered by the assay and wherein N=6 and X=5.

Fig. 18 is the same as Fig. 17 except that N=6 and
5 X=3.

Fig. 19 is a plot of the intensity of the principle maxima I_0 versus the number of slits.

Fig. 20(a)-20(b) is an alternate embodiment of a two or more slit embodiment in which the assay
10 substrate is formed with slits.

Fig. 21(a) is an alternate embodiment in which the slit opening is replaced by a square opening.

Fig. 21(b) is an alternate embodiment of Fig. 20(a) wherein the slit opening is triangular in shape.
15

Figs. 21(c) and (d) illustrate formation of an assay on a diagonal half of a square slit to form a triangular based diffraction pattern.

Description of the Preferred Embodiment

A. Background Theory

20 In 1801 Thomas Young demonstrated the phenomenon of interference bands produced by a light shining through two identical and closely spaced slits. A diagram of the optical configuration used by Young is shown in Figure 1. A light source (S) is incident on
25 two narrow, parallel slits (S_1 and S_2). Each slit has a width (D) which can be very small but remain larger than the wavelength of light. The slits are separated by a distance (a), which exceeds D. The light passing through the slits is diffracted and emerges as two
30 wavefronts with identical wavelength and phase. The two wavefronts interfere and produce a visible

-13-

interference pattern on the screen 20. The pattern consists of a series of bright and dark parallel bands which are typically referred to as fringes.

The overall light amplitude at any given point in
5 the interference pattern is the result of the superposition of the two wave amplitudes from S_1 and S_2 . Two waves that add constructively produce a bright fringe (maxima) while two waves that add destructively produce a dark fringe (minima). The distance between
10 two adjacent maxima is calculated by:

$$Y = \frac{m\lambda X}{D} \quad \text{Eq. (1)}$$

where X is the distance from the slits to the screen, λ is the wavelength of the light, and m is an integer
15 used to designate the position of the fringe. The central fringe, located on the symmetry axis, is called the zero-order maximum. The first maximum on either side ($m = \pm 1$), is called the first-order maximum, and the maxima continue in either direction, through the
20 higher orders. The minima are located exactly halfway between the maxima and are completely dark only when the two slits provide equal intensities.

When working with Eq. 1 the quantities X and a are both controlled by the experimental design and the
25 value for Y can be measured from the fringe pattern, leaving only λ as an unknown value. Thus, one can use this equation to determine the wavelength of light, which was another historical achievement of the original double-slit experiment.

30 When only one of the two slits is open a broad central diffraction peak is obtained centered on the open slit as shown in Fig. 2, curve a. With two slits open, the overlapping wavefronts of the diffraction

-14-

bands produced by the individual slits combine to form an interference pattern located within the boundaries of the diffraction bands; the interference fringes are visible where each of the diffraction bands would have
5 been observed.

B. Principle of Assay based on Double-Slit Interference Pattern

The assay of the invention is based on a transduction mechanism of double-slit or multi-slit
10 interference modulation. As stated previously, complete loss of transmission through only one slit in a double-slit interference configuration will produce a collapse of the fringe pattern to the single-slit diffraction band. A partial loss of transmission
15 produces an intermediate pattern where the amplitudes of the interference maxima and minima are moving towards the condition of the diffraction band envelope. Therefore, any method of reducing the transparency of a slit can be related to a loss of fringe pattern.

20 One way to convert this process to an assay is to provide a chemistry which produces a localized coverage over one slit which is opaque enough to reduce the transmission of light through the slit. The reduction of light through the slit decreases the intensity of
25 light available for interference with light emanating from the other slit, and thus decreases the formation of the resulting fringe pattern. In practice, the surface coverage due to the assay is equated with a predictable change of fringe pattern.

30 The chemistry for producing loss of transmission through a slit can involve the temporary or permanent localization on the surface of the slit of any

-15-

optically dense molecule or material which will cause a scattering or absorbance of the incident radiation from a source. Any physical phenomena that can alter or attenuate radiation transmission can affect the

5 interference fringe formation. Therefore, any chemical phenomena producing one or more of these physical phenomena can potentially be assayed by this technology. The physical phenomena may comprise a change in reflectance, absorbance, phase, refraction,

10 or polarization of light impinging on an assay. Items capable of behaving thusly include colloidal gold-labeled molecules, colorimetric labels and pigments, bacteria, polymeric particles, cells, Langmuir-Blodgett films, as well as other polymeric films.

15 For loss of transmission by means of light absorbance, materials must be used that absorb at the frequency of the incident light. Table 1 below lists the spectral color and associated wavelengths of a variety of colored compounds. For example, using a

20 HeNe laser which emits a light of wavelength 630 nm, one would predict that blue/blue-green materials would absorb the energy. If one wanted to detect, for example, a yellow compound then the laser source would be changed to one working in the 430 nm range.

25 An absorbance-modulated interference system may also be used to detect multiple analytes in a sample with a variable, incoherent source, such as a Xenon arc lamp and a scanning monochromater. As a scanning spectrophotometer measures an absorbance spectrum as a

30 function of the frequency of the incident radiation it may also be possible to measure the interference patterns produced by the transmissions at different frequencies. In this way, one could analyze a sample

-16-

containing a variety of molecules with non-overlapping absorbance spectra; at a radiation wavelength coinciding with the absorbance maximum of a particular molecule in the sample the decrease of the interference pattern would be due to the attenuation resulting from the concentration of the molecule. Each molecule in the sample would cause attenuation of transmission at a discrete wavelength, and in this way multiple analytes could be detected in the region of a single slit (S₂).

10

TABLE 1COLORS OF COMPOUNDS, SPECTRAL COLORS AND WAVELENGTHS

	<u>Color of Compound</u>	<u>Spectral color absorbed</u>	<u>Approx. wavelength (nm)</u>
15	Colorless	Ultraviolet	<400
	Lemon Yellow	Violet	410
	Yellow	Indigo	430
	Orange	Blue	480
	Red	Blue-green	500
20	Purple	Green	530
	Violet	Lemon yellow	560
	Indigo	Yellow	580
	Blue	Orange	610
	Blue-green	Red	680
25	Green	Purple-red	720
	Colorless	Infrared	>720

C. Preferred Embodiment of Apparatus of the Invention

Turning now to Fig. 3 the apparatus for a first embodiment of the invention will be described in

-17-

connection therewith.

A light source 10 is disposed on a track (not shown) of an optical bench adjacent and in line with a foil mask 24 which is also mounted on the track. Mask 5 24 is formed with at least two narrow vertical slits S_1 and S_2 . An assay is formed on assay slide 14 which is positioned on mask 24 so as to cover slit S_1 .

An optional filter 12 is disposed on the track between source 10 and mask 24. If source 10 is a laser 10 emitting highly intense monochromatic light, filter 12 may be a neutral density filter used to adjust the intensity of the light. If source 10 is a broad band moderately intense light source, filter 12 may be used to filter all but the desired wavelength for projection 15 on the mask 24.

Light passing through the slits S_1 and S_2 is diffracted and the resulting wavefronts of diffracted light interfere to create a fringe pattern 22 which is magnified by lens 16 and projected onto screen 20. 20 Note: Optionally, a second lens (not shown) may be disposed on the side of the mask nearest the source to increase the distribution of the pattern at the origin O. Camera 18 is used to photographically record the image of the pattern. This image may then be processed 25 by converting the fringe patterns to intensity graphs using a densitometer and analyzing the intensity graphs produced with and without the slit covered by the assay to determine the concentration of the ligand in the

-18-

assay.

The double-slit mask component 24 is a critical item in this process and must be of high quality. Preferably the mask is cut out of foil by a laser process. Three different sizes have been experimented with as shown in Table 2 below. Those skilled in the art will appreciate that the dimensions indicated have been arbitrarily selected from a continuum of suitable values, and are exemplary rather than limiting on the invention.

TABLE 2

DIMENSIONS OF AIR SLITS

	<u>Foil #</u>	<u>Slit width</u> <u>(μm)</u>	<u>Slit separ.</u> <u>(μm)</u>	<u>Slit length</u> <u>(mm)</u>
15	1	100	500	10
	2	50	500	2
	3	50	1000	2

Foil #2 produces the most intense and distinct fringe patterns in the current format. The fringe separation (Y) for this foil when placed at X distance from a screen are determined from Eq. 1 and are listed in Table 3 below.

-19-

TABLE 3CALCULATED FRINGE SEPARATIONS FOR FOIL #2 AT VARYING
DISTANCES BETWEEN SLITS AND SCREEN

	<u>X (cm)</u>	<u>a (μm)</u>	<u>λ (μm)</u>	<u>Y (μm)</u>
5	50	550	0.633	575.4
	40	550	0.633	460.4
	30	550	0.633	345.2
	20	550	0.633	230.2
	10	550	0.633	115.1
10	5	550	0.633	57.5

The foil mask is secured on a magnetic mount (not shown) which is then placed on a magnetic strip attached to an X-Y-Z positioned in line with the light source 10. The assay requires positioning of the assay slide over one slit and this must be done so that the slide edge remains between two slits and does not cause any diffraction of the light beam transmitting through the uncovered slit.

In an experimental model the light source comprised a HeNe laser (Uniphase, 2mW), generating monochromatic light at 633 nm. Neutral density filters were used to reduce the laser intensity.

The fringe patterns were recorded on film (Polaroid film #667, 3000ASA) and subsequently converted to intensity graphs by a video densitometer

-20-

(PFGplus 640-3-U-RT PCVision Plus Frame Grabber with a 640x480 Display, OPTIMAS - Optical Measurement & Analysis Software, PVM-1342Q Sony Trinitron 13" color monitor with multiple inputs, Logimouse Plus - Logitech
5 Mechanical Mouse, SYS/386-80-color-1 IBM Compatible 386 20 Mhz with EGA Color Monitor and 80 Megabyte Hard Drive) using a video camera (815-2000-0000 Cohu Series 4800 High Resolution CCD Monochrome Camera) focused on
10 the illuminated photographs. To make a tracing the cursor was positioned at the top of a fringe pattern or diffraction envelope with the single-slit, and then drawn through the center of the pattern and terminated at the opposing side.

D. Assay Chemistry

15 A flow chart of a first embodiment of the assay chemistry of the invention followed by the optical test is summarized in Figs. 4a-g. In this assay the ligand is rabbit IgG which is incubated with a coverslip 14 (Fig. 4a) coated with anti-rabbit IgG, followed by
20 incubation with a colloidal gold-labeled anti-ligand, such as, goat anti-rabbit IgG 40 (Fig. 4b). After a silver enhancement step, wherein the gold colloid nucleates precipitation of silver from a solution 42 as it comes into contact with the labeled antibody in the
25 assay (Fig. 4c), the coverslip exhibits a deposition of darkly stained antibody-antigen complex. Insertion of this treated assay coverslip over one slit S_2 of a

-21-

double-slit configuration produces loss of transparency through slit S_1 (Fig. 4d) resulting in loss of intensity I_1 of light from S_1 (Fig. 4e) and an observable, measurable loss of interference fringes (Fig. 4f). This loss in amplitude of fringes is then related to analyte concentration (Fig. 4g) in the quantification procedure described later in Section E.

The above general description of the methodology of the assay preparation is followed by the specific experimental example below:

The objective of the immobilization chemistry is covalent attachment of the anti-ligand, in this case a protein, which will selectively bind the target ligand or analyte. To prepare the glass for the immobilization chemistry the coverslip is acid treated to produce reactive silanol groups:

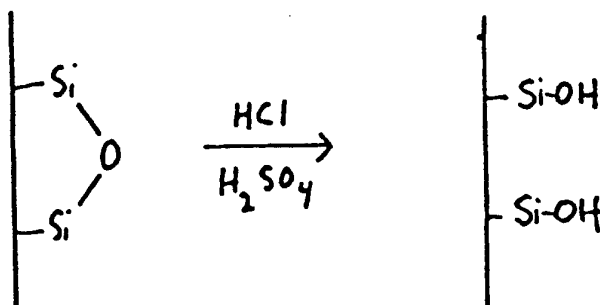

In a first example, this was accomplished as follows: Glass coverslips (81mm²) were soaked in a 1:1 mixture of concentrated HCl and methanol, followed by several rinses with distilled H₂O. Coverslips were then soaked in hydrosulfuric acid for 30 min., followed

-22-

by several rinses with distilled H₂O. Coverslips were boiled in distilled H₂O for 30 minutes and then air-dried on low lint paper. (see Bhaia, S.K., Shriver-Lake, L.C., Prior, K.J., Georger, J.H., Calvert, J.M.,
 5 Bredeborst, R., Ligler, F.S., Analytical Biochemistry, 178, 408-413, 1989.)

Next the glass is reacted with aminoethylpropyltriethoxysilane (APTES), to produce a reactive, amine-derivatized surface:

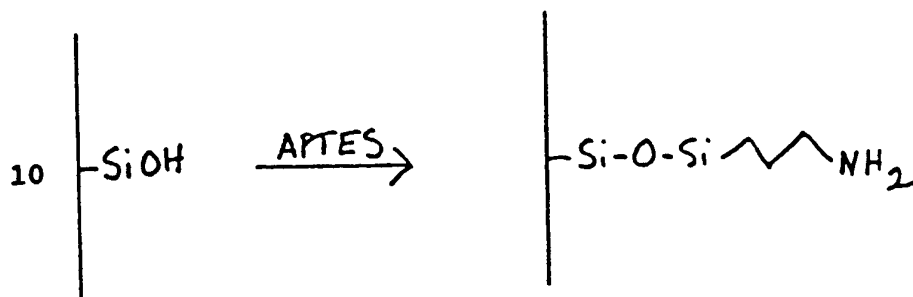

Specifically, a 2% solution (v/v) of APTES was prepared by mixing 200 μ l of APTES in 9.8 ml toluene (dried over molecular sieves). The coverslips were soaked for 2 h, and rinsed in dry toluene. (see
 15 Weetal, H.H., "Methods of Enzymology", Mosach, K., Ed., Academic Press: New York, 1976, Vol. XLIV, pp 139).
 The next step is the reaction of the amine derivatized glass with succinic anhydride to produce a carboxylic acid group on the surface:

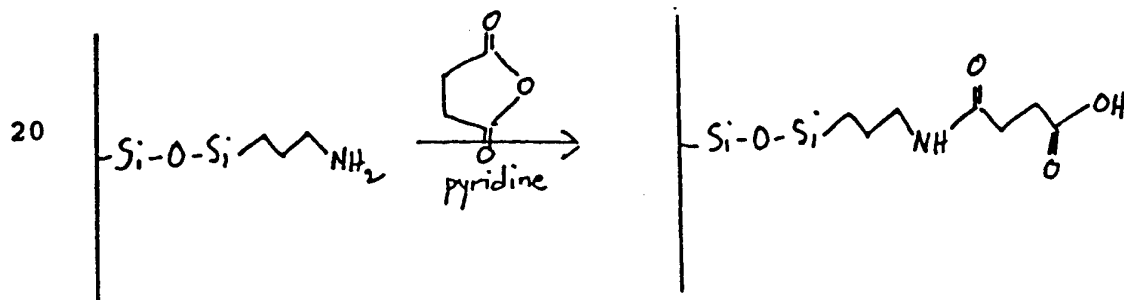

-23-

A solution of 0.20 g (2 mmol) succinic anhydride was combined with 40 mg (0.33 mmol) 4-dimethylamino-pyridine in 6 ml anhydrous pyridine and divided into test tubes. The amine-derivatized glass coverslips were placed into the tubes, which were then sealed and shaken at room temperature for 16-20 hours. Coverslips were removed, rinsed with pyridine, methylene chloride and ether. If stored, they were placed in a desiccator over P₂O₅. (see Damha, M.J., P.A., Zabarylo, S.V., Nucleic Acid Research, 18 (13), 33813, 1990.)

The glass is now ready for the carbodiimide chemistry which begins with activation of the succinylated surface with 1-ethyl-3-(3-dimethylaminopropyl) carbodiimide hydrochloride (EDC):

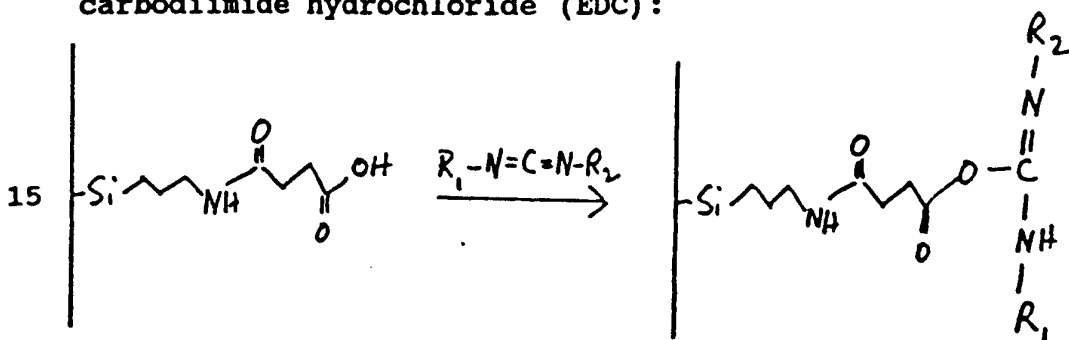

The procedure and reagents were those recommended with the Carbodiimide Kit for Carboxylated Microparticles (Polysciences, Inc., #19539). Carboxylated coverslips were soaked in carbonate buffer (Bottle #1) for 5 min, and then in phosphate buffer (Bottle #2) for 5 min. A 0.6 ml phosphate buffer was placed in test tubes with prepared coverslips. A 2% solution of carbodiimide solution was prepared by mixing 75.0 mg EDC with 3.75 ml phosphate buffer. 0.6 ml EDC solution was added, dropwise, to each of the test tubes containing the

coverslips, and capped tightly. The solutions were shaken for 3.5 - 4 hours at room temperature. The coverslips were then removed and shaken in borate buffer (Bottle #4) for 5 min. followed by two more 5 rinsings with borate buffer. The activated surface is then reacted with the alkylamine functional groups of the protein (anti-rabbit IgG) to be immobilized, forming an amide linkage:

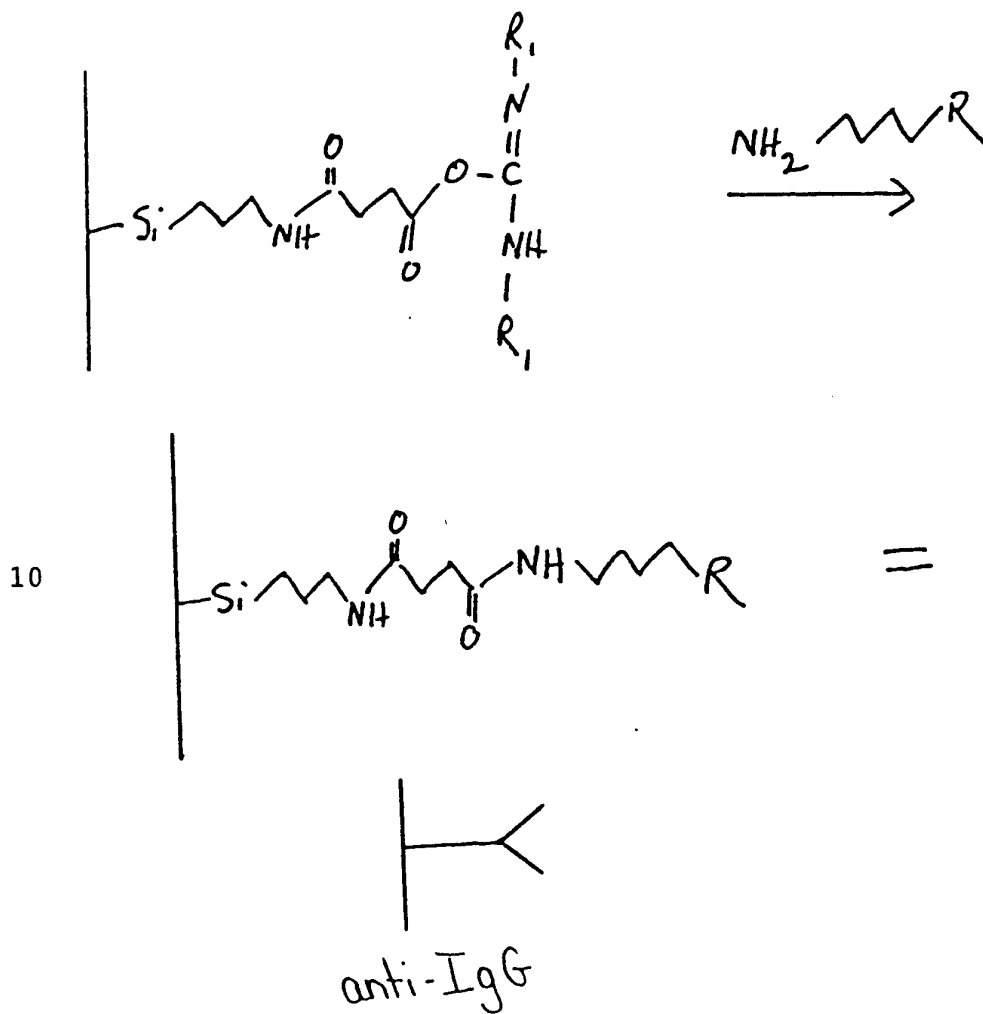

-25-

For the protein reaction a 0.05 mg/ml solution of anti-rabbit IgG was prepared by adding 73 ul of anti-rabbit IgG (4.1 mg/ml; commercially available from Sigma) to 6 ml borate buffer, which was then aliquotted into 6 test tubes. The coverslips were immersed, the test tubes were sealed and rocked gently overnight. The coverslips were removed and the supernatant was retained for absorbance measurements. For the blocking reaction the coverslips were then added to test tubes containing 1 ml 0.1 M ethanolamine (Bottle #5) and gently mixed for 30 min. The coverslips were then transferred to 1 ml of BSA solution (Bottle #6) and gently mixed for 30 min. The coverslips were then rinsed in PBS and stored in storage buffer (Bottle #7) or PBS, 4 - 6 degrees.

The protein used as the anti-ligand can also be immobilized to a transparent plastic substrate that has been coated with a polymer containing residual carboxylate groups (Sera-Coat, Seradyn) for carbodiimide coupling.

For the assay, rabbit IgG was incubated with the anti-rabbit IgG coverslips, rinsed with PBS, and then treated with gold-labeled anti-rabbit IgG, and the silver enhancement step.

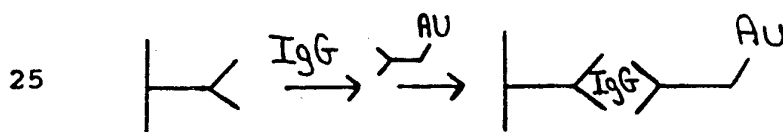

Specifically, the coverslips were rinsed with PBS two times. For ease of handling, a coverslip was positioned in the outer groove of a disposable cuvette and 20-40 ul of colloidal gold(30nm)-labeled Goat anti-
 5 rabbit IgG (AuroProbe EM GAR G30, Amersham) was pipetted onto the surface and left for 60 min. The coverslip was then placed inside the same cuvette and rinsed thoroughly three times with PBS followed by three rinses with H₂O.

10 A silver enhancement step follows which produces a more dramatic decrease in the transparency of the reacted assay. In this step the gold nucleates precipitation of silver from a solution in the region of the labeled antibody:

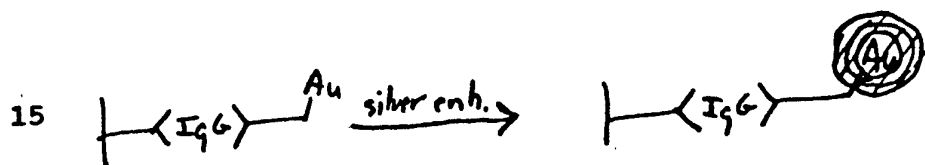

This was achieved using the IntenSE Silver Enhancement Kit (RPN.491, Amersham). A solution was prepared by combining equal number of drops from solutions A and B. The enhancement solution was
 20 pipetted into cuvettes containing individual gold-labeled antibody treated coverslips and reacted for 6-18 min. at room temperature. The coverslips were then rinsed with distilled H₂O. The reaction can be repeated to increase the effect.

-27-

E. Quantitation of the Assay

Equations have been derived for describing the dependency of the interference fringes on the luminescence intensities produced by the slits, and those equations can be employed in this detection method for quantifying the assay.

The equation for describing a quality termed the visibility (V_1) of the fringe pattern can be calculated by the relative intensities (I_1 and I_2) of the source light transmitted through the two identical slits (S_1 and S_2), as shown in Figure 1 and can be calculated thusly:

$$V_1 = \frac{2\sqrt{I_1} \sqrt{I_2}}{I_1 + I_2} |\gamma_{12}| \quad \text{Eq. (2)}$$

where I_1 and I_2 are the intensities at point P from the radiation passing through the slits 1 and 2 when viewed independent of each other, and $|\gamma_{12}| = 1$ is a coherency limit for a laser source.

The visibility (V_2) can also be calculated by the intensity of the fringes:

$$V_2 = \frac{I_{\max} - I_{\min}}{I_{\max} + I_{\min}} \quad \text{Eq. (3)}$$

where I_{\max} and I_{\min} are the intensities corresponding to a maximum and an adjacent minimum in the fringe system.

-28-

I_{\max} and I_{\min} are functions of the light intensities transmitted through the slits S_1 and S_2 :

$$I_{\max} = I_1 + I_2 + 2\sqrt{I_1 I_2} |\gamma_{12}| \quad \text{Eq. (4)}$$

5

$$I_{\min} = I_1 + I_2 - 2\sqrt{I_1 I_2} |\gamma_{12}| \quad \text{Eq. (5)}$$

Since I_{\max} and I_{\min} are determined by I_1 and I_2 then it follows that the two visibility equations should produce identical values ($V_1 = V_2$).

10 If the intensity for I_1 is held constant while the intensity of I_2 is reduced one can calculate the change in the fringe pattern. Table 4 contains values for a model system where the intensity (I_1 and I_2) through each slit are assigned a value of 10. When the
15 intensity is identical through each slit the upper value of 1.0 exists for V_2 ; as the intensity, I_2 , is decreased the V_2 decreases towards 0.0. When $V_2 = 1.0$, the fringe pattern has the maximum amplitude of I_{\max} and a complete loss of amplitude at I_{\min} . As V_2 moves
20 towards 0.0 the fringe pattern collapses to the diffraction envelope.

TABLE 4
THE CHANGES IN I_{MAX} AND I_{MIN} WITH LOSS OF
TRANSMISSION THROUGH ONE SLIT

5	<u>I₁</u>	<u>I₂</u>	<u>I_{max}</u>	<u>I_{min}</u>	$V_2 = \frac{I_{max} - I_{min}}{I_{max} + I_{min}}$	<u>Group</u>
	10	10	40.0	0	1.0	A
	10	9.5	38.99	0.006	0.999	
	10	9.0	37.97	0.026	0.998	
10	10	8.0	35.88	0.111	0.993	
	10	7.0	33.73	0.266	0.984	
	10	6.0	31.49	0.508	0.968	
	10	5.0	29.14	0.86	0.94	B
	10	2.0	20.94	3.05	0.74	C
15	10	1.0	17.32	4.68	0.57	D
	10	0.1	12.10	8.10	0.19	E
	10	0.01	1.64	9.38	0.063	F

A graph of two adjacent fringes is shown in Figure 5. The line labeled A describes the intensities of I_{max} and I_{min} formed by two equal, unobstructed slits. The lines B through F show the change in amplitudes as the intensity through one slit is decreased. At the I_{max} for line F the intensity amplitude is almost 10, which is the intensity of light passing through the unobstructed slit, or I₁.

It is important to appreciate that the summation of the two slit intensities (I₁ + I₂) without the phenomenon of constructive interference, would be, in Figure 5, a value of 20. Thus, the intensity of I_{max} observed in lines A through C, where the amplitude is

-30-

greater than 20, is due to constructive interference. Thus, the amplitude values between 20 and 40 represent an increased signal content for the correlation of assay information.

5 The intensity of I_{\max} at point P can also be quantified from the attenuation of I_2 due to a change in absorbance ($\Delta A = \Delta \epsilon bc$) of the sample. The existing formulas which govern absorbance spectroscopy can be linked with the formulas used for evaluating
10 interference phenomena since both methodologies are based on transmission intensity of a source and the resultant intensity due to passing the radiation through a sample.

Transmission, T, is defined as the ratio of the
15 intensity of unabsorbed radiation, I, to the intensity of the incident radiation, I/I_0 . From Beer's Law, exists the relationship between ϵbc and T, where ϵ = the extinction coefficient of the absorbing species, b = path length of cell, and c = concentration of
20 species:

$$\frac{I}{I_0} = 10^{-\epsilon bc} = 10^{-A} \quad \text{Eq. (6)}$$

25 In the proposed configuration for measuring interference phenomena the I_2 transmission intensity can be viewed as a ratio of the intensity of unabsorbed radiation to the intensity of incident radiation, I_1/I_0 :

$$I_1 = \text{unmodulated beam} = I_0 \quad \text{Eq. (7)}$$

30

$$I_2 = \text{assay beam} = \frac{I_x}{I_0} \quad \text{Eq. (8)}$$

-31-

From Eq. 6:

$$\frac{I_x}{I_0} = 10^{-\epsilon bc}$$

$$5 \quad I_x = I_0 \cdot 10^{-\epsilon bc} \quad \text{Eq. (9)}$$

Substitution of the preceding identities into the I_{\max} equation results in an I_{\max} expression as a function of absorbance defined by ϵbc for a particular species:

$$10 \quad I_{\max} = I_1 + I_2 + 2\sqrt{I_1 I_2} \quad \text{Eq. (10)}$$

$$I_{\max} = I_0 + \frac{I_x}{I_0} + 2\sqrt{I_0 \frac{I_x}{I_0}} \quad \text{Eq. (11)}$$

$$15 \quad I_{\max} = I_0 + \frac{I_x}{I_0} + 2\sqrt{I_x} \quad \text{Eq. (12)}$$

$$I_{\max} = I_0 + 10^{-\epsilon bc} + 2\sqrt{I_0 \cdot 10^{-\epsilon bc}} \quad \text{Eq. (13)}$$

20 Of interest is a comparison of the relative signal change of both ΔT and ΔI_{\max} for identical sample concentration and volume. The transmission values for an absorbance series ($\Delta \epsilon bc$) as measured in a standard spectrophotometer are shown in Table 5, along with the

25 I_{\max} values calculated from Eq. 13 for the same series. Both functions, ΔT and ΔI_{\max} , are plotted in Figure 6. For any given concentration change the ΔI_{\max} function has a greater dynamic range than the ΔT function for the same variation in ϵbc . For example, the change in

30 concentration between 0.25 and 0.50 absorbance units will produce a ΔI_{\max} of 0.55 units of intensity change and a ΔT of 0.23 units of intensity change. Therefore,

the ΔI_{\max} function would be more than 2 times as sensitive as the ΔT function. The increased dynamic range results from the fact that Eq. 13 contains two terms which change as a function of absorbance modulation. Since sensitivity of spectroscopic analysis is defined by the magnitude of absorptivity as well as the minimum absorbance which can be measured with the required degree of certainty, the ΔI_{\max} function would provide greater spectrophotometric sensitivity.

TABLE 5

I_{\max} VALUES CALCULATED FROM AN ABSORBANCE SERIES

	ϵbc	$T = 10^{-\epsilon bc}$	$2\sqrt{I_0 \cdot 10^{-\epsilon bc}}$	I_0	I_{\max}
15	.01	0.977	1.976	1.0	3.95
	.1	0.794	1.782	1.0	3.57
	.2	0.630	1.587	1.0	3.21
	.3	0.501	1.415	1.0	2.91
20	.4	0.398	1.261	1.0	2.66
	.5	0.316	1.124	1.0	2.44
	1.0	0.100	0.632	1.0	1.73
	1.5	0.031	0.352	1.0	1.38
	2.0	0.010	0.200	1.0	1.21

-33-

F. Dynamic Range of the Optical Detection System

The dynamic range of a signal transduction mechanism is understood to be the degree of change of signal per unit of change in concentration of the
 5 analyte:

$$\text{Dynamic range} = \frac{\Delta \text{ signal}}{\Delta \text{ concentration}}$$

As the degree of signal change per concentration
 10 change increases so does the detectability of the signal as well as the accuracy or resolution of the concentration measurements.

The V_2 (Eq. 3) is plotted in Figure 7(a) as a function of the percent of transmission ($I_2\%$) through
 15 the second slit (S_2) (Table 4). At 100% transmission, equal intensities pass through two identical slits and the fringe pattern has the most defined fringes, where I_{max} is at its highest value and I_{min} is zero. At 0% complete loss of the fringe pattern occurs and only the
 20 diffraction envelope remains. On the graph shown in Figure 7(a) one can arbitrarily assign 40 units on the visibility scale. In the assay, the change in transmission through S_2 is a function of the concentration of analyte bound to the coverslip, and
 25 therefore the $I_2\%$ is the concentration component. The dynamic range is therefore:

$$\text{Dynamic range} = \frac{\Delta V_2}{\Delta I_2\%} \quad \text{Eq. (14)}$$

30 One can see by the graph of Fig. 7(a) that this relationship is not fixed but changes rather drastically as the $\Delta I_2\%$ approaches zero. Of the 40 units of signal division a loss of 50% transmission in

-34-

I_2 produces a visibility change from 1.0 to 0.94, or 2.5 units of signal. The dynamic range would be 0.05, calculated thusly:

$$5 \quad \frac{\Delta V_1}{\Delta I_2\%} = \frac{2.5}{50} 0.05$$

A loss of transmission in I_2 from 50% to 0% produces a visibility change from 0.94 to 0.0, or 37.5 units of signal, and an increase of dynamic range to 0.75.

10 Thus, one can see that the dynamic range is clearly a function of the degree of transmission loss and it increase significantly as the transmission approaches zero. A more linear plot of the Visibility (V_2) data can be generated by plotting $-\log V_2 \times 1000$ against ΔI_2 ,
15 which is shown in Figure 7(b).

However, the change in fringe visibility is not the only useful function for calculating a dynamic response. Using the model and values from Table 4, the change in I_{\max} and I_{\min} as a function of $\Delta I_2\%$ is shown in
20 Figure 8. Where there is no loss of transmission the I_{\max} is at its highest amplitude, 40.0, and the I_{\min} is at its lowest amplitude, 0.0. With complete loss of transmission both values approach identical values of 10.0, which is the intensity through one open slit. If
25 the $I_2\%$ changes form 100 to 50% the dynamic range in terms of I_{\max} is 0.22;

$$\text{Dynamic Range} = \frac{\Delta I_{\max}}{\Delta I_2\%} = \frac{11}{50} 0.22 \quad \text{Eq. (15)}$$

30 which is significantly greater than the dynamic range calculated in terms of ΔV_2 , as plotted in Figure 7(a).

-35-

The dynamic response of the I_{\min} over the same range is 0.012. Now, if the transmission loss creates a $\Delta I_2\%$ of 50% to 0% the dynamic range in terms of I_{\max} becomes 0.38.

5 Again, these calculations are made over large, arbitrary segments of the graph and are gross averages. But they do indicate that an appreciation of the dynamic range must be associated with a specified form of the signal measurement (V or I_{\max}) and must be
10 carefully calibrated over the full percentage of transmission loss. Nevertheless, both of these graphs indicate that a significantly changing function can be correlated with a change in percent of I_2 transmission and its contribution to fringe pattern values can be
15 subsequently correlated with analyte concentration.

A very interesting aspect of this detection method should be considered at this point. Also plotted in Figure 8 is the function C which represents the loss of intensity of I_2 if monitored independently. A decrease
20 from 100 to 50% transmission produces only 5 units of signal change and has a dynamic range of 0.10. The change from 50 to 0% transmission has the same number of signal units and thus the same dynamic range. Therefore 0.1 is the limiting dynamic range for a
25 linear loss of transmission measurement and this is considerably less than the dynamic range produced by a transduction mechanism based on a changing amplitude of an interference fringe, as described in the preceding analyses of the graphs in Figures 7 and 8.

30 Therefore, the slit format, in principle, is more sensitive than straight optical density. This enhanced

-36-

sensitivity can be appreciated by comparing the relative resolutions of the measurements. Resolution is conventionally taken as the inverse of the dynamic range. For a dynamic range of 0.10, as calculated for
5 the linear loss of transmission, the resolution, or number that can be measured with certainty, would be 10.00. For a dynamic range of 0.22, as calculated for the change in I_{\max} from 100 to 50% loss of transmission, the resolution would be 4.54, meaning that the
10 certainty of the measured value would be to a smaller number than the preceding case, and thus more accurate. A dynamic range of 0.75 has a resolution of 1.33, providing even more accuracy.

The sensitivity of this assay is defined by the
15 number of target molecules required to obstruct the transmission through S_2 to produce a measurable change in the fringe pattern. Several factors will contribute to the ultimate sensitivity:

1. The size of the slit.
- 20 2. The limiting concentration of immobilized anti-ligand on the coverslip.
3. The limiting concentration of analyte and gold labeled-antibody coupled to the assay surface from the solution.
- 25 4. The contribution of the silver precipitation step to the transmission loss.
5. The ability to make a kinetic measurement with the silver precipitation reaction.

An analysis of potential sensitivity was based on

a paper (Bhatia et al. Anal. Biochem. 178, 408, 1989) that optimized covalent immobilization of antibody to a glass surface. The concentrations of bound antibody to both coverslip and optical fiber substrates are shown
 5 below.

COMPARISON OF ANTIBODY BINDING TO COVERSIP AND FIBER

	Coverslip	Optical Fiber
<u>Area</u>	<u>968 mm²</u>	<u>74 mm²</u>
10 Antibody immobilized	638±134ng (0.66 ng/mm ² , 4 fmol/mm ²)	71±3ng (0.96 ng/mm ² , 6 fmol/mm ²)
Specific antigen binding	350±50 ng (0.36 ng/mm ²)	27±4ng (0.36 ng/mm ²)

15 For a slit of size 5 μm x 100 μm, a sensitivity of 6 x 10⁵ molecules may be calculated as follows:

$$\text{Slit size: } 5 \mu\text{m} \times 100 \mu\text{m} = 500 \mu\text{m}^2 = 500 \times 10^6 \text{ nm}^2$$

Maximum antibody immobilized on slit area:

$$20 \quad \frac{4 \text{ fmol}}{10^6 \mu\text{m}^2} = \frac{x}{500 \mu\text{m}^2}$$

$$x = 0.002 \text{ fmol}$$

$$\text{Antigen capture (50\%)} = 0.001 \text{ fmol}$$

$$= 6 \times 10^5 \text{ molecules}$$

$$25 \quad \text{Labeled antibody capture (50\%)} = 0.0005 \text{ fmol}$$

$$= 3 \times 10^5 \text{ molecules}$$

-38-

The area of the colloid gold label of 30 nm:

$$\begin{aligned} \text{Area} &= \pi r^2 \\ &= 706.5 \text{ nm}^2 \end{aligned}$$

The theoretical number of molecules required to
5 cover the entire slit can be estimated by:

$$\frac{\text{Area of slit}}{\text{Area of gold colloid}} = \frac{500 \times 10^6 \text{ nm}^2}{706.5 \text{ nm}^2/\text{molecule}} = 7 \times 10^5 \text{ molecules}$$

$$10 \quad \frac{\text{Ratio of experimentally captured antibody}}{\text{Theoretical requirement for slit coverage}} = \frac{3 \times 10^5 \text{ molecules}}{7 \times 10^5 \text{ molecules}} = 0.43$$

However, this theoretical treatment does not include the effect of the silver precipitation step,
15 which appears to make the most significant contribution in the change of intensity of the coverslip. If 3×10^5 molecules of gold-labeled antibody covers 43% of the slit, a reduction of the transmission to 57% should reduce the intensity of I_{max} by ca.25% (Figure 8). The
20 silver precipitation may extend the sensitivity well below this estimation of 3×10^5 molecules. In some of the experiments no gold-labeled antibody was observable by the naked eye on the coverslip until after the precipitation step, at which point the coverslip became
25 significantly opaque.

The detection method of the invention possesses a number of substantial advantages. The signal output is in the form of both an amplitude parameter and a pattern formation which offers greater information

-39-

content for data analysis over a system based only on intensity measurement. For an interference assay, the signal, in the form of the entire interference pattern, may be stored in computer memory and compared with a computer standard so that a microscopic alteration to the assay standard pattern, detectable only through computerized treatment, could deliver an exquisitely sensitive diagnostic.

Another advantage of the transduction method of the invention is that the amplitude component in the form of I_{\max} has been increased fourfold over a direct measurement of intensity, due to the contribution of the two individual wavefronts as well as the constructively interfering electromagnetic waves. Again, this increases the information content of the potential signal which should increase the dynamic range and thus the sensitivity of the assay. A sensitivity of less than 10^5 molecules is possible which would equal or exceed the sensitivity of isotopic methods.

Another underlying quality which should make this methodology very competitive with other detection techniques is the simplicity of its optical design and principles as well as ease of assay procedure. Such simplicity can lead to ruggedness as well as economy. A compact bench top instrument should be easily manufacturable, with the assay chemistry incorporated into a disposable dipstick. For use with gold-labeled antibody reagents, the dipstick would require incubations with sample, gold-labeled antibody, and silver enhancement solutions, which could be

-40-

accomplished in 1 - 2 hours. For use with a bacterial cell, simple incubation with the sample, followed by rinsing would complete the procedure. (It may be possible that as few as 2 - 3 bound cells would suffice
5 to alter the fringe pattern).

And finally, this is a generic system which could be used for any clinical or environmental samples participating in specific, recognition events. Assays based on immunochemistry and DNA would be the initial
10 areas of development. Eventually other molecular recognition systems, such as chemical receptors, cyclodextrins, or ion-selective membranes, may be incorporated into analytical applications. This system could also be used in the study of material science
15 processes, such as monitoring crystal growth, photo-induced polymerizations, and surface film depositions.

G. Alternate Embodiments

Numerous variations of the basic embodiment previously described are contemplated. For example,
20 the slit number and shape may be varied. The present preferred embodiment is a double-slit formed of two identical, parallel slits, but predictable interference phenomena can be produced by other numbers of identical slits. With more than two slits it would be possible
25 to assign individual assays to a different slit or test assays in each slit would be for multiple analytes with a single procedure.

Although the visibility equations previously described are not derived for non-identical parallel
30 slits, it may be possible that this assay would be enhanced with non-identical slits.

-41-

Also, holes may be used in place of slits to form a circular interference pattern. For example, two pinholes will also produce interference fringes and can be precision made to about 2 μm in diameter, which
5 would give a smaller total surface area than the proposed slits (and thus enhance sensitivity). The assay chemistry could be performed as drops on the pinhole, therefore using very minute sample volumes.

The assay occurring on the glass coverslip 50
10 could also serve to produce two slits S_1 and S_2 from a single slit S_0 as shown in Fig. 9a-9d. In this case the anti-ligand S_2 is immobilized on an edge of the coverslip (Fig. 9(b)). The assay would darken the edge of the coverslip, Fig. 9(c), which would then be
15 positioned over the single slit S_0 Fig. 9(a) as shown in Fig. 9(d) forming two slits S_1 and S_2 .

The assay chemistry could be centralized on a glass slit 90 so that gold-labeled antibody assay forms a double slit 92 as shown in Fig. 10.

20 It is also possible, as shown in Fig. 11, to produce double-slit interference fringes by optical configurations that create virtual slits. Although the principle of the assay would be the same as heretofore described, the alteration of transmission would require
25 interference with the geometry producing the virtual slit.

In this arrangement light rays from a single slit S_1 pass to the screen 80 via two paths, one of which is direct, A-A, and the other of which is an indirect
30 path, B-B, created by reflection from a mirror M placed in the center line C/L so as to produce a reflection

-42-

which would appear to emanate from a slit S_2 located equidistant from center line C/L. The source is therefore viewed by two paths, one direct and one reflected at a glancing angle in a mirror. The reflection reverses the phase 180° , but otherwise the analysis and the fringes are the same. The area of reflection on the mirror would be the location of the assay chemistry, which would cause appearance or loss of reflection.

10 The previous configuration involves use of a Lloyd's mirror. A Fresnel's mirror can be used as in Fig. 12 to produce two virtual slits which are formed with a point source S projected on two plane mirrors, M_1 and M_2 , mutually inclined at a small angle.

15 The two resulting virtual images, S_1 and S_2 , act as coherent sources. The separation of S_1 and S_2 is defined:

$$d = 2b \sin \alpha$$

where α is the angle between the mirrors. Again the assay would be placed on one of the mirrors and the resultant change in reflectivity used to correlate the analyte concentration.

25 Two equal prisms when placed together, base to base as in Fig. 13, with their refracting edges parallel, form a Fresnel bi-prism and will divide a cone of light from source S into two overlapping cones. The prisms thus form two virtual slit images, S_1 and S_2 . A so-called Billet's split lens arrangement formed by two convex lens can form two images, both of which are

-43-

real as shown in Fig. 14.

With all of these optical arrangements, interference fringes are formed in the region defined by the diverging cones from the sources S_1 and S_2 .

5 Assays could be developed which altered the optical arrangement, thus altering fringe patterns. For example, application to the Lloyd's mirror (Fig. 11) or Fresnel's mirror (Fig. 12) configurations would require location of the assay chemistry in the region of
10 reflection on the mirror, which produces the virtual slit. If the assay chemistry resulted in a loss of reflectivity of the mirror's surface the intensity of reflected light would decrease and the interference pattern would be modulated. Application to the Fresnel
15 bi-prism (Fig. 13) or Billet's split lens (Fig. 14) would require location of the assay chemistry on one of the prisms or lenses so that the post-assay intensity of diffracted radiation would no longer equal the intensity diffracted by the other optical unit in the
20 pair.

As shown in Fig. 15, reactions could be monitored by use of a transport flow-cell microcell 94 which would build up an interfering absorbance on screen 96. In Fig. 15, B is a reference cuvette, A is an assay
25 cuvette, and they are divided by the cuvette separation, C. The progress of the reaction produces a molecular population that would either remain in the flow cell A or become entrapped on its surface, and thus make the transmitted light non-identical to that
30 passing through cell B.

Another configuration would have slits S_1 and S_2

incorporated into a transport flow cell 86 as in Fig. 16. The cell 86 is disposed opposite a Source 85. Antiligand would be immobilized on S₁ and buildup of ligand on its surface would alter the fringe pattern as seen by the detector 87.

The dynamic range of the detection system may be enhanced not only by increasing the number of slits, but by increasing the number of slits covered by the assay. Table 6 below shows how the intensity of the principle maxima increases as a function of N² times the intensity I₀ of one slit.

TABLE 6
INTENSITY OF PRINCIPAL MAXIMA FROM N SLITS IS N² X I₀

#	<u>Slits</u>	<u>I</u>	<u>I₀ = 10</u>
15	1	I ₀	10
	2	4I ₀	40
	3	9I ₀	90
	4	16I ₀	160
20	5	25I ₀	250
	6	36I ₀	360
	7	49I ₀	490

Fig. 19 is a plot of the data from Table 6. As shown in Fig. 17, if the assay slide 100 covers 5 out of 6 slits 104 of the mask 102 the intensity range increases by 350 units; instead of 1 of 2 in which case as follows: 6 slits, I = 360, 1 slit I = 10, the change Δ = 350 whereas in the two slit system Δ = 30 as follows 2 slits I = 40, 1 slit I = 10, and Δ = 40-10 or 30.

-45-

If only 3 slits are covered on a 6 slit mask as in Fig. 18 the resultant $\Delta = 270$ computed as follows:

$$\begin{array}{r}
 6 \text{ slits, } I = 360 \\
 3 \text{ slits, } I = \underline{90} \\
 5 \qquad \qquad \Delta \qquad = 270
 \end{array}$$

Note: The slits dedicated to the assay need not be adjacent.

The assay substrate 60 could also contain the slits S_1 and S_2 (Fig. 20(a)) with the anti-ligand 62 immobilized to one of the slits (i.e. S_1). The assay reaction causes slit S_1 to become less transparent (Fig. 20b). In this embodiment the optical radiation is passed through identical slit material, preserving the symmetrical phases of the two wavefronts. Also, any nonspecific binding of protein from the sample would occur equally in the regions of S_1 and S_2 , again preserving the symmetry of I_1 and I_2 since both intensities would be identically altered by the contaminating material.

Fig. 21(a) and 21(b) illustrates alternate embodiments in which the mask or assay slit 70/70' is square shaped (Fig. 21a) or triangular (Fig. 21(b)) in shape. A single square slit will produce an interference pattern 72 as shown in Fig. 21(a). Likewise, a single triangular shaped slit 70' produces the pattern 72' of Fig. 21(b).

By immobilizing anti-ligand 74 on a diagonal half of square slit 70 as in Fig. 21(c) and reacting the

-46-

anti-ligand with an appropriate ligand in an assay, the square slit 70 becomes a triangular slit Fig. 21(d), and a triangular based diffraction pattern 72' occurs Fig. 21(b). A detector (not shown) monitors the appearance of the new diffraction pattern 72' to determine the presence and concentration of the ligand.

Equivalents

Those skilled in the art will recognize, or be able to ascertain, using no more than routine experimentation, many equivalents to the specific embodiments of the invention described herein.

These and all other equivalents are intended to be encompassed by the following claims. For example, while the invention has been described in connection with light waves in the visible spectrum, the invention is applicable to any electromagnetic waves throughout the entire spectrum.

-47-

CLAIMS

1. A method of optical detection of the presence of a ligand in an assay in which a ligand is reacted with an antiligand to cause a change in the optical characteristics of the assay comprising the steps of:
 - a) forming an interference pattern by projecting light in a path which causes the projected light to split into more than one light beam, which split beams interfere with one another to create said pattern;
 - b) disturbing at least one such split beam by introducing the assay in the path of the beam thereby changing the interference pattern; and
 - c) observing the change in the pattern to determine the presence of the ligand.
2. The method of Claim 1 wherein the light is split by diffraction through openings in a mask disposed in the path.
3. The method of Claim 2 wherein the change in optical characteristics results from a phenomena from the group comprising scattering, absorbance, phase change, refraction or polarization of the incident light.
4. The method of Claim 1 wherein the change in the pattern is dependent on the concentration of the ligand in the assay and includes the step of

-48-

correlating the change to determine such concentration.

5. A method for providing an optical indication of the relative concentration of a ligand and an antiligand in an assay comprising the following steps:
- 5
- a) forming an interference pattern by projecting light through a mask having N slits wherein N is an integer greater than one;
- 10 b) covering $N-X$ slits with an assay comprised of said ligand and antiligand which when reacted results in change in an optical characteristic of the covered slits and a resultant change in the interference pattern, and wherein X is an integer less than N ;
- 15 c) determining the concentration by measuring the change in the optical characteristic of one or more points on the interference pattern before and after the $N-X$ slits are covered.
- 20
6. The method of Claim 5 wherein the points in step (c) are substantially all points within a range of points within the interference pattern.
7. The method of Claim 5 wherein either the ligand or anti-ligand is an optically dense molecule which causes a scattering, absorbance, phase, refraction or polarization change of incident light.
- 25
8. The method of Claim 1 wherein $N = 6$ and $X = 5$.

-49-

9. The method of Claim 1 wherein $N = 2$ and $X = 1$.
10. The method of Claim 5 wherein the concentration is measured by determining a visibility parameter and comparing the determined visibility to a reference curve of visibility versus concentration.
- 5
11. The method of Claim 5 wherein the assay is comprised of a ligand and a metal-labeled anti-ligand.
12. A method of providing an optical indication of the presence of a ligand or an antiligand in an assay comprising the following steps:
- 10
- a) forming an interference pattern by projecting light through a mask having N slits wherein N is an integer greater than one.
- 15
- b) covering $N - X$ slits, where X is an integer less than N , with an assay comprised of said ligand and antiligand; and
- c) reacting the ligand and antiligand to produce a loss in transparency through the $N - X$ covered slits indicating the presence of the
- 20
- ligand or antiligand.
13. Apparatus for detecting the presence or concentration of a ligand in an assay comprising :
- a) a light source for emitting a beam of light;
- 25
- b) a beam splitter for causing the beam of light to split into at least two split beams, which split beams interfere with one another to form an interference pattern and

-50-

- c) an assay for modulating one of the split beams to change the interference pattern in a manner related to the concentration of ligand in the assay;
 - 5 d) detection means for quantifying the pattern change and determining therefrom the concentration of ligand.
14. The apparatus of Claim 13 wherein the beam splitter comprises a mask having at least two
10 slits for diffracting the beam of light.
15. The apparatus of Claim 14 wherein the light source is a laser.
16. The apparatus of Claim 15 wherein the detection means comprises an optoelectronic detector.
- 15 17. A method of determining the concentration of a ligand in an assay comprising the steps of:
- a) generating an interference pattern by interference between two or more electromagnetic waves;
 - 20 b) reacting the ligand with an antiligand in the assay to cause a change in the response of the assay to the waves;
 - c) modulating the interference pattern by disposing the reacted assay in the path of
25 one of the waves;
 - d) determining the ligand concentration by the change in the interference pattern.

-51-

18. The method of Claim 17 wherein the electromagnetic waves comprise light waves.
19. The method of Claim 18 wherein the change in response is a change resulting from scattering,
5 absorbance, polarization or refraction.
20. The method of Claim 18 wherein the interference results from passing the waves through N slits formed in a mask wherein N is an integer.
21. The method of Claim 20 wherein the slits are
10 square shaped.
22. The method of Claim 20 wherein the slits are triangular shaped.
23. The method of Claim 20 wherein the assay is
15 comprised of an assay substrate containing the slits.
24. The method of Claim 23 wherein N is greater than one and X is an integer less than N and X slits are covered by the assay.
25. The method of Claim 17 wherein the change in the
20 interference pattern is determined by a densitometer.

-52-

26. The method of Claim 17 wherein the change in the interference pattern is determined by calculating the visibility parameter of the pattern and comparing the visibility parameter with a reference curve of visibility versus ligand concentration.
27. The method of Claim 18 wherein the interference pattern is produced by one or more virtual slit(s).
28. The method of Claim 27 wherein the virtual slit(s) are produced by a device from the class comprising Lloyd's mirror, a Fresnel's mirror, a Fresnel biprism, or a Billet's split lens.
29. The method of Claim 20 wherein the slits are incorporated into a flow cell in which antiligand is immobilized.
30. Apparatus for determining the concentration of a ligand in an assay comprising:
- a) an interferometer for generating interference between two or more waves to form an interference pattern;
 - b) an antiligand, which when reacted with the ligand in the assay causes a ligand concentration dependent change in the response of the assay to the waves;
 - c) said assay being disposed in the path of one of the waves so as to modulate the interference pattern and

-53-

- d) detector means for detecting changes in the interference pattern caused by the modulations and correlating the detected changes with ligand concentration.
- 5 31. The apparatus of Claim 30 wherein the waves are light waves.
32. The apparatus of Claim 31 wherein the interference pattern is produced by passing light from a light source through one or more slit(s) whereby the
10 light is diffracted to produce one or more light beams which interfere with one another to produce said interference pattern.
33. The apparatus of Claim 31 wherein the modulation results from scattering, absorbance, polarization
15 or refraction of the light waves.
34. The apparatus of Claim 31 wherein the slits are formed on a substrate which supports the assay.
35. The apparatus of Claim 31 wherein the assay is an immunoassay.
- 20 36. The apparatus of Claim 31 wherein the ligand is taken from the group comprising: molecules, bacteria, polymeric particles, cells and films.

-54-

37. The apparatus of Claim 31 wherein the ligand absorbs light in a predetermined frequency range and a light source generates the light waves within that range.

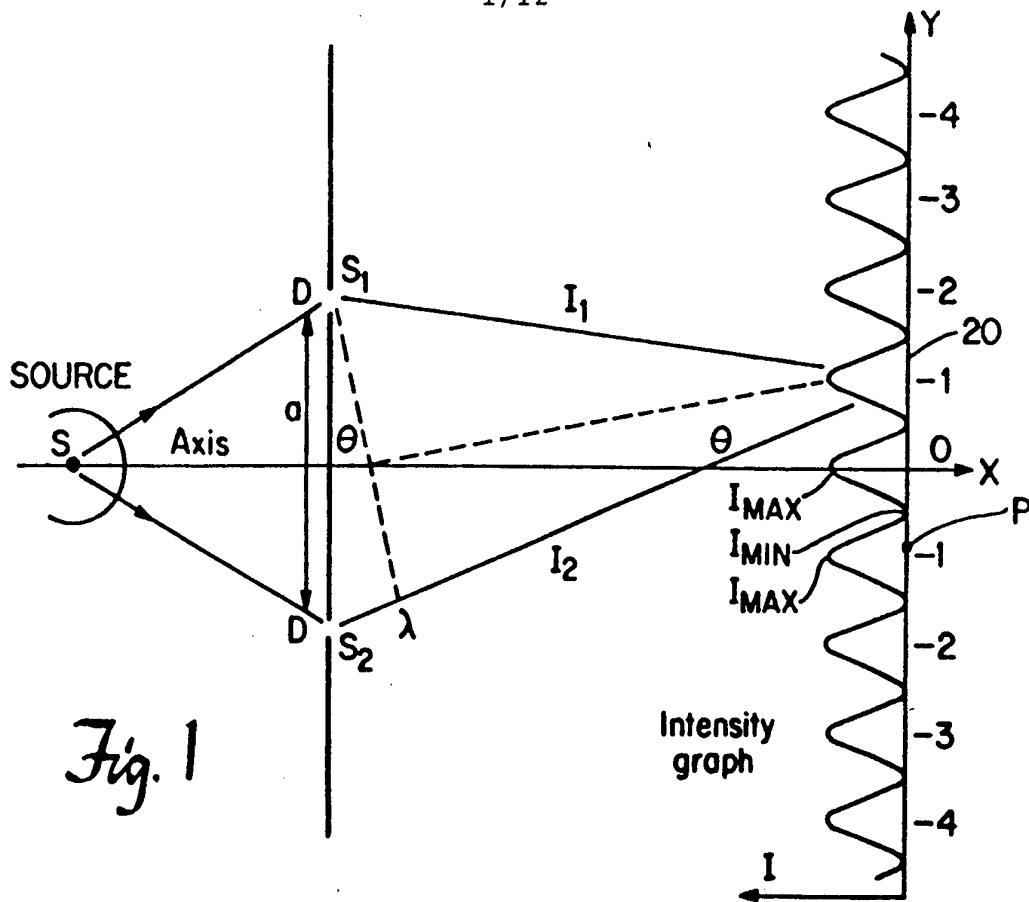

Fig. 1

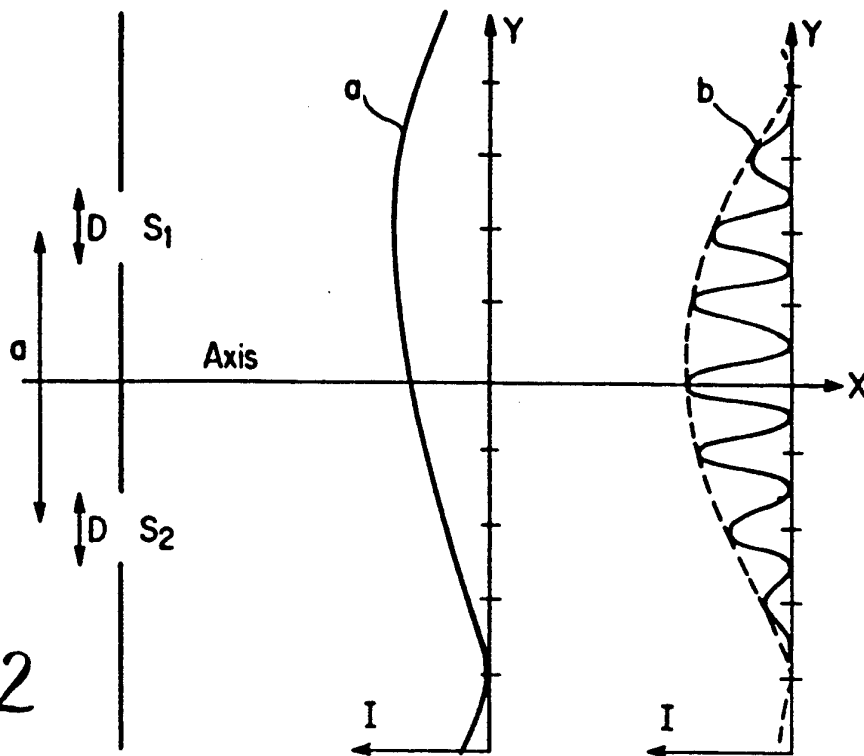

Fig. 2

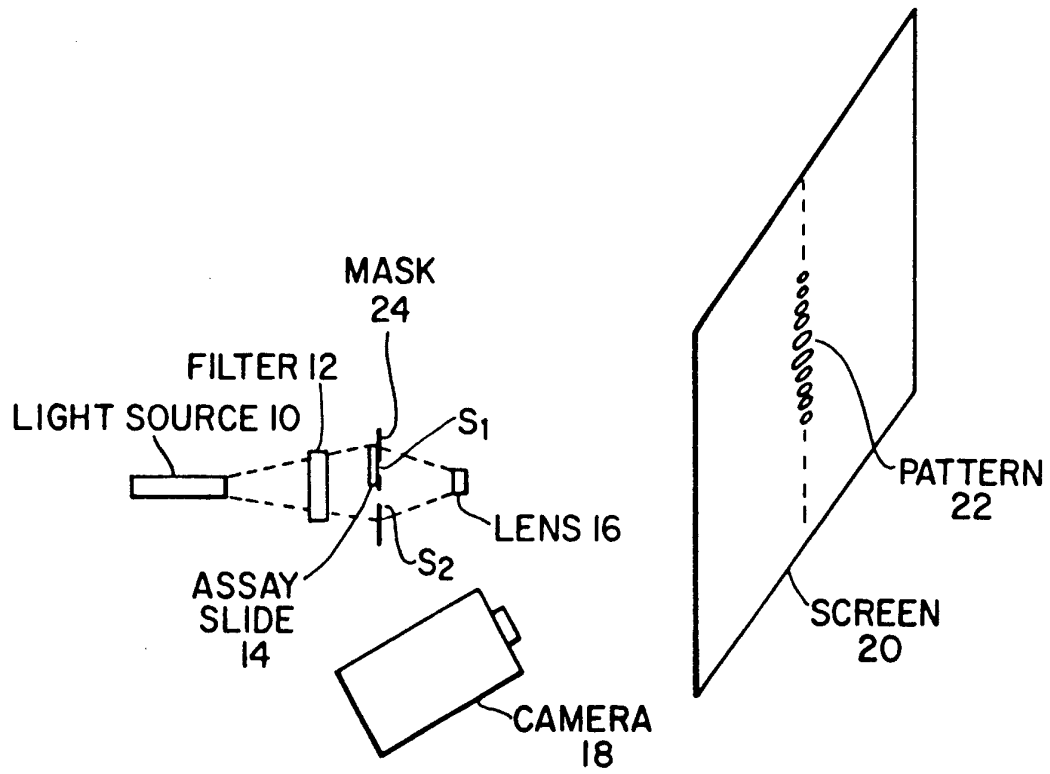
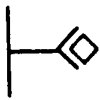
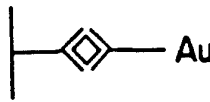
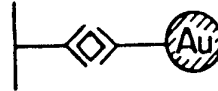
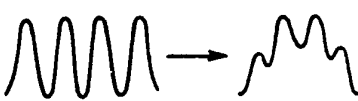

Fig. 3

CHEMICAL

- Fig. 4a*  Analyte capture on assay slide
- Fig. 4b*  Au-antibody capture
- Fig. 4c*  Silver precipitation

OPTICAL

- Fig. 4d* $S_2 < S_1$ Loss of transparency, S_2
- Fig. 4e* $I_2 < I_1$ Loss of transmission, I_2
- Fig. 4f*  Fringe modulation from I_2 decreases
- Fig. 4g* $\Delta V \propto \Delta \text{conc.}$ Relate change in fringe to concentration analyte

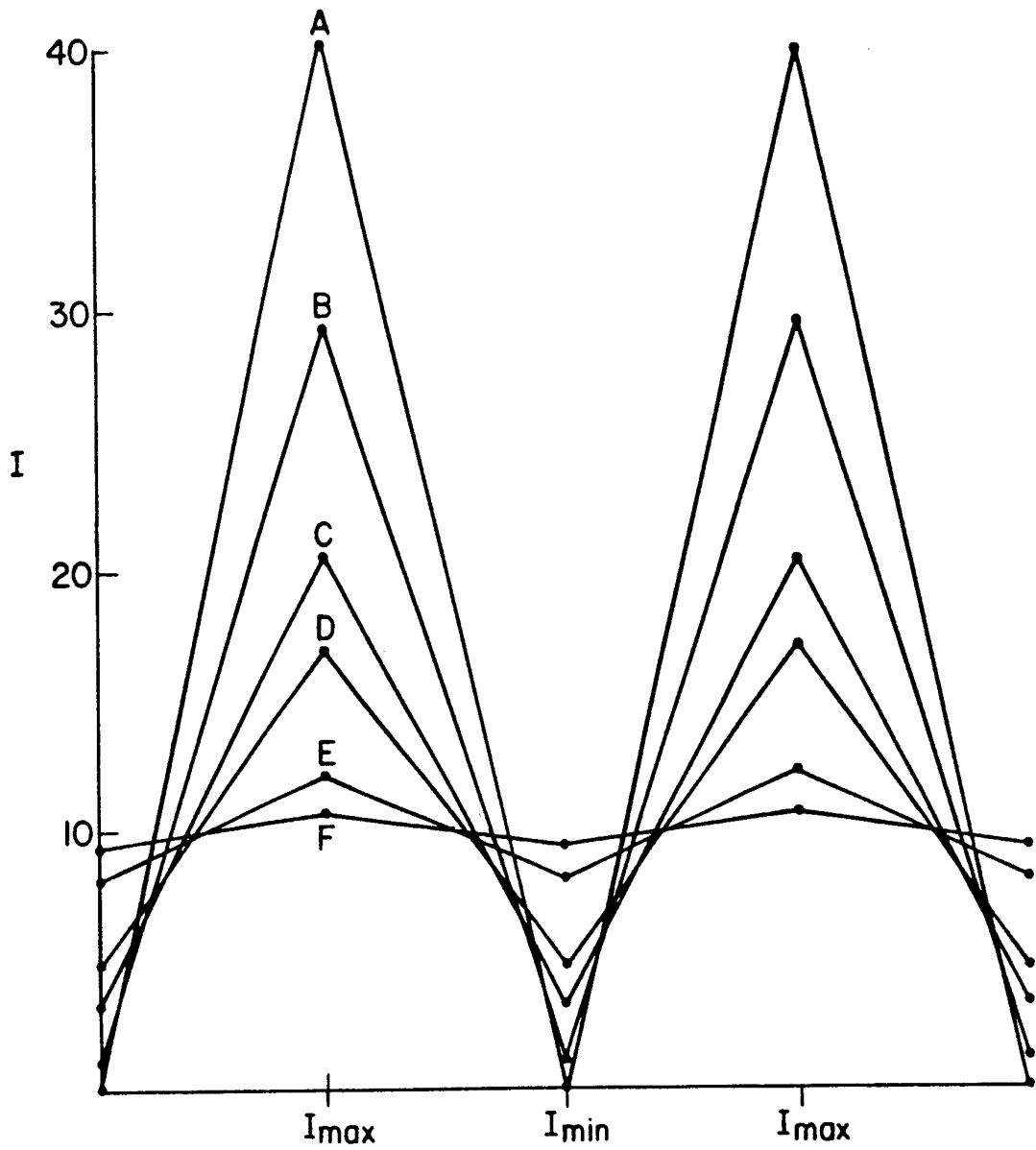

Fig. 5

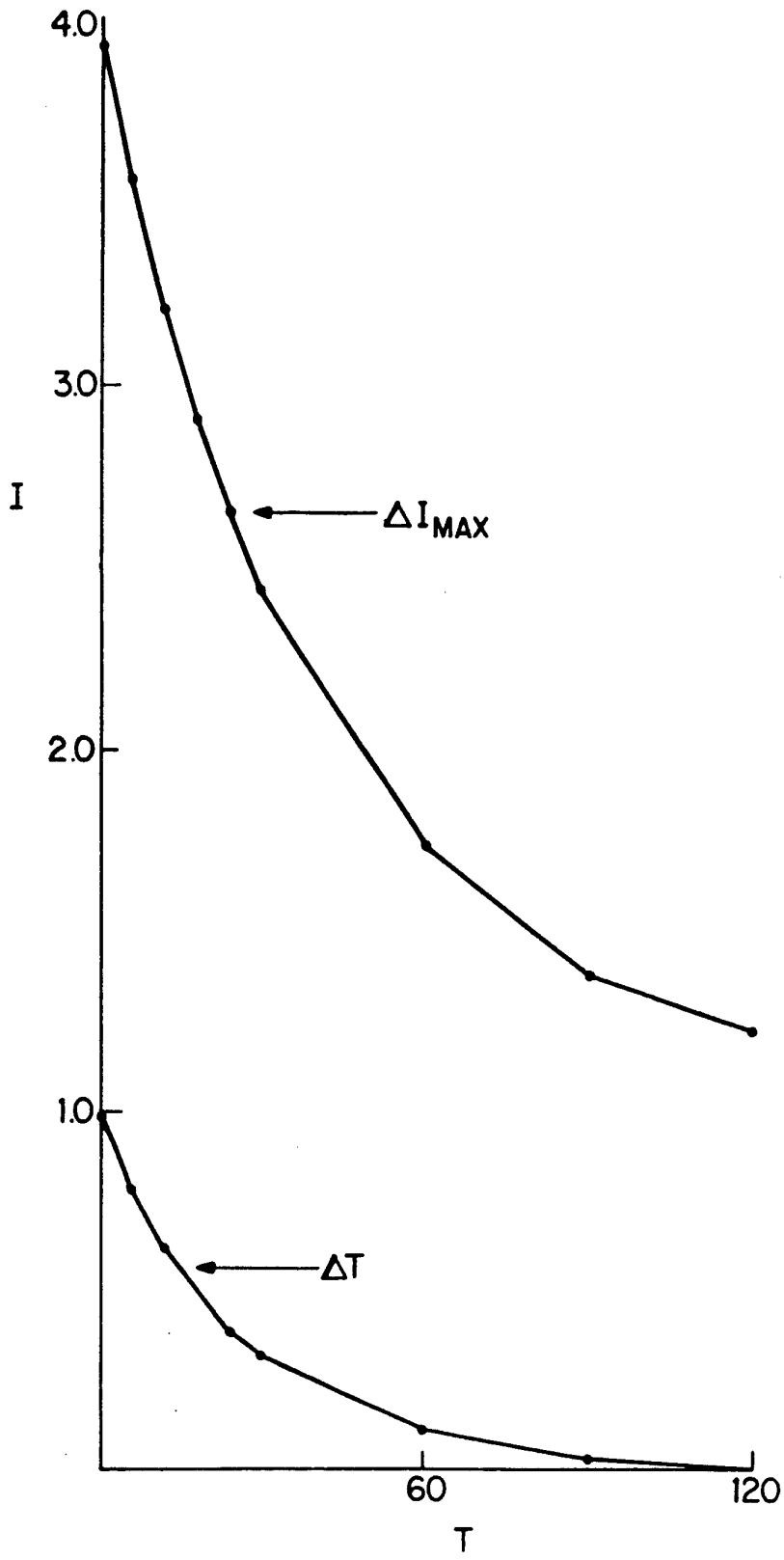

Fig. 6

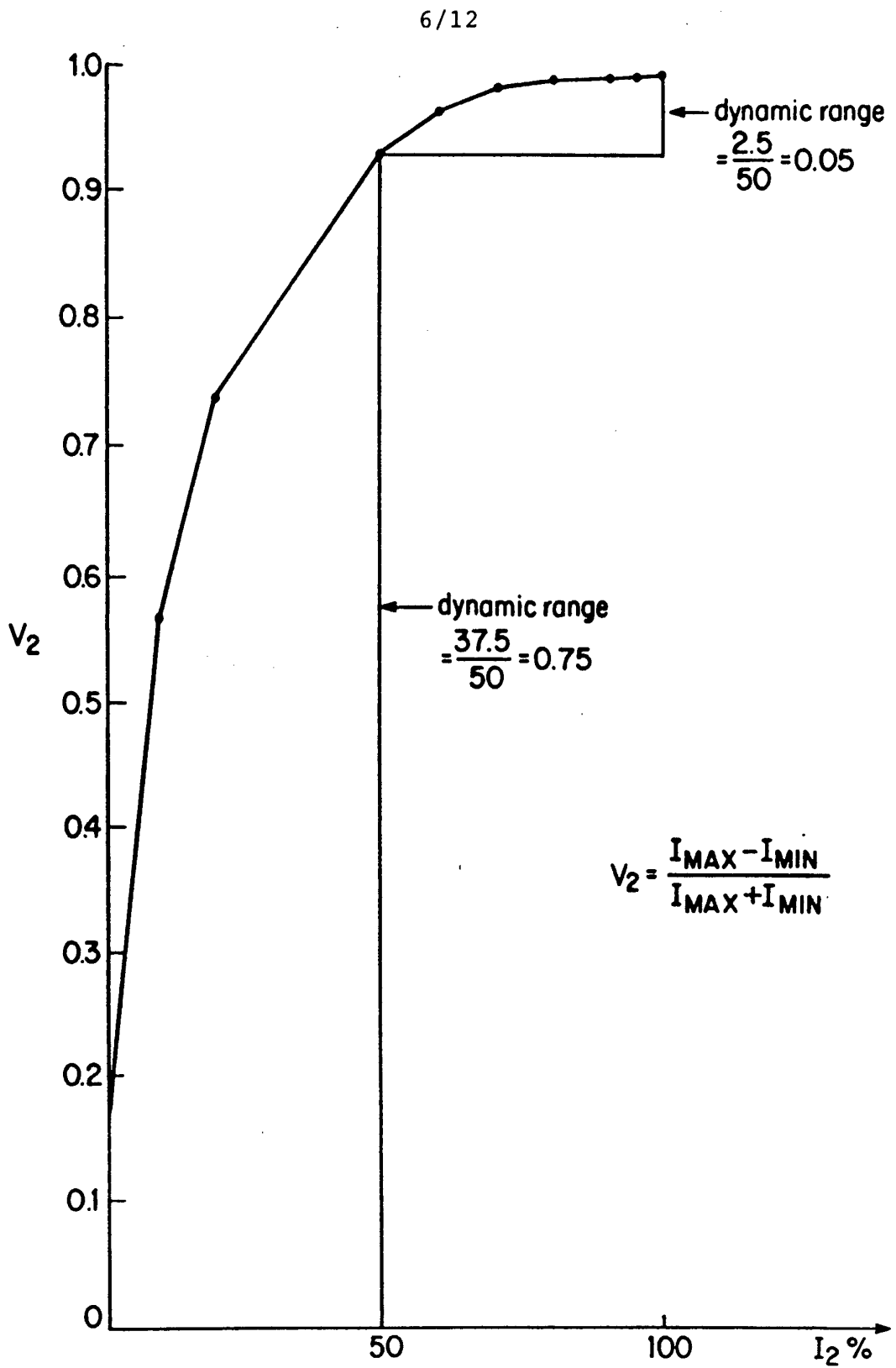

Fig. 7a

7/12

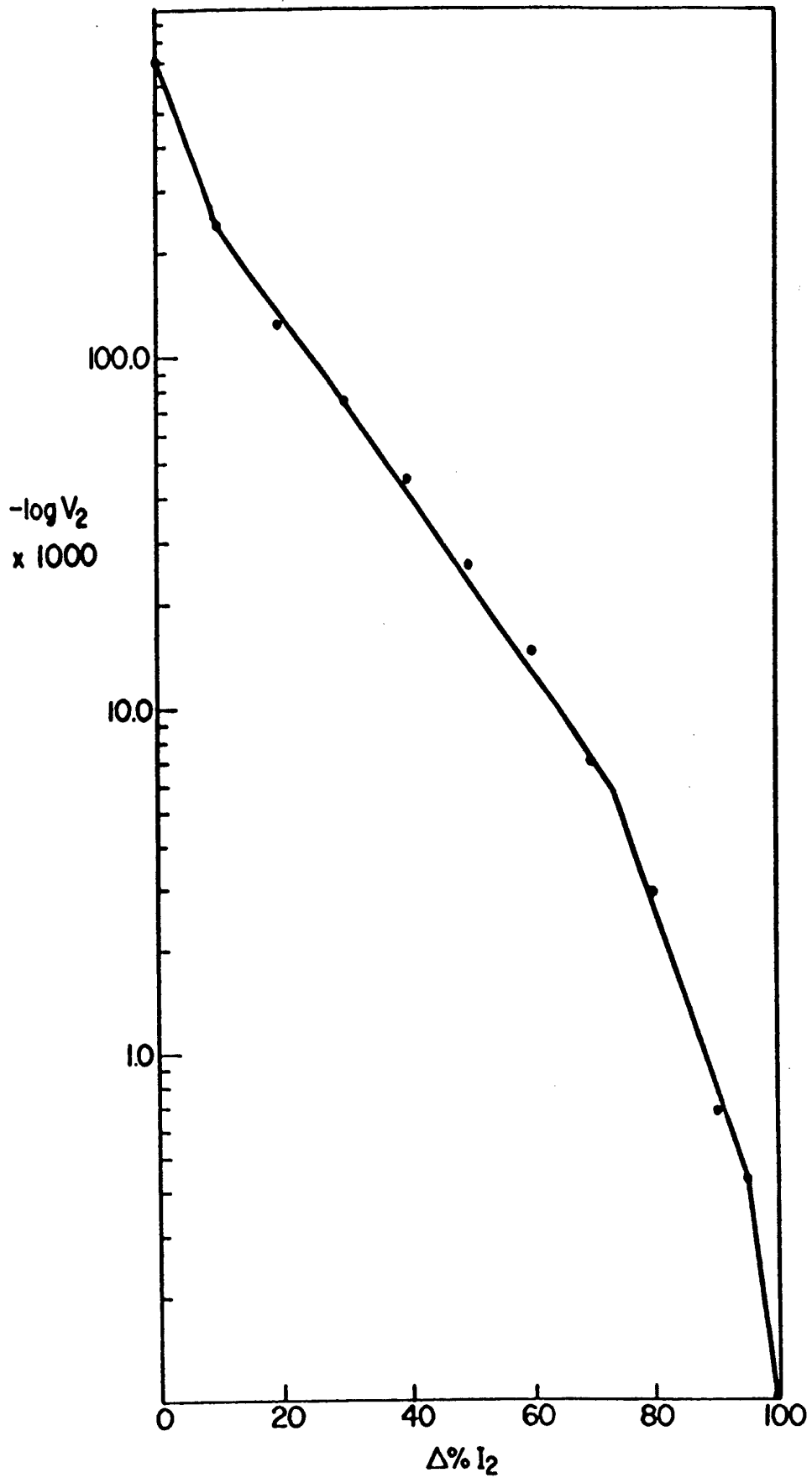

Fig. 7b

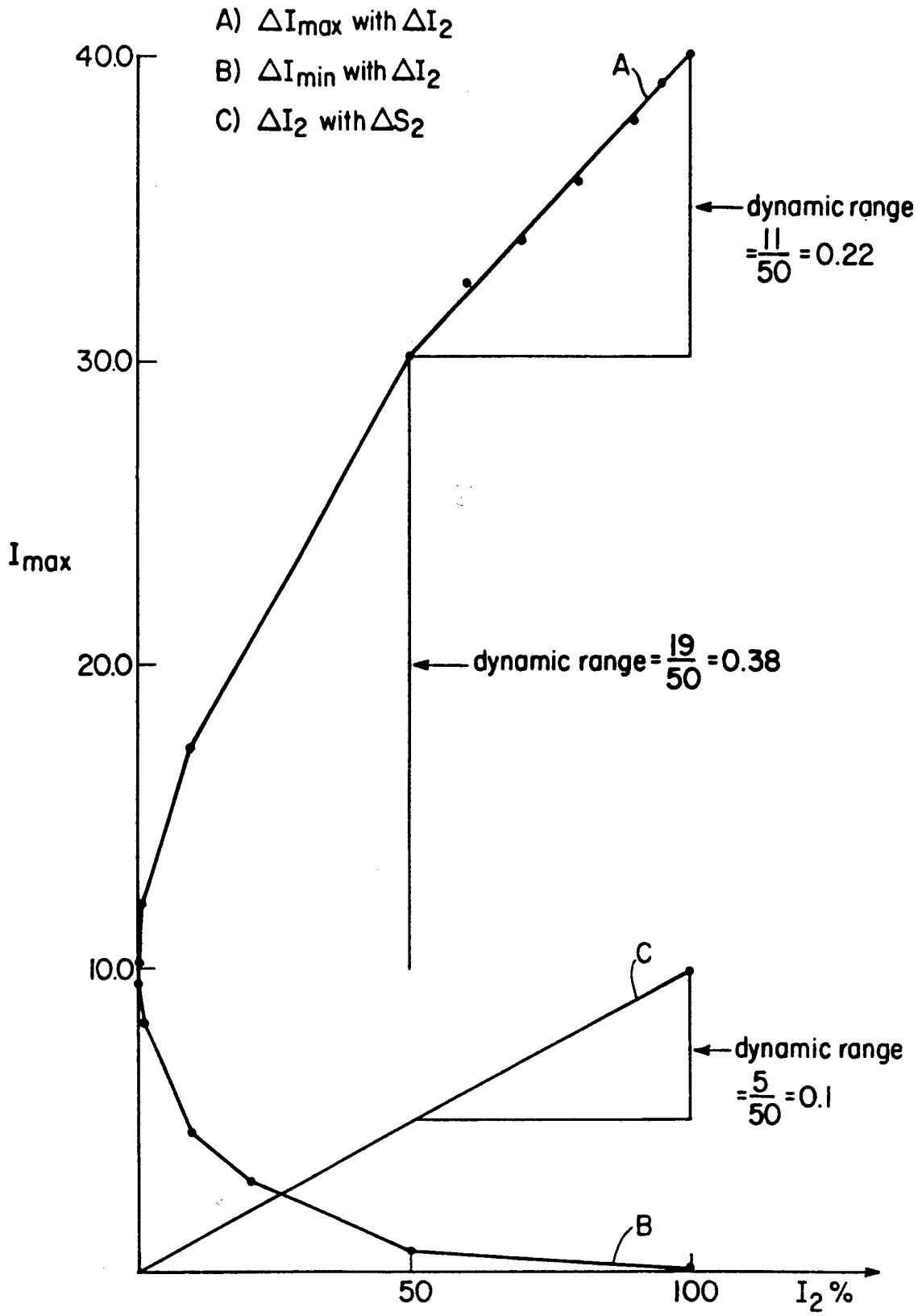
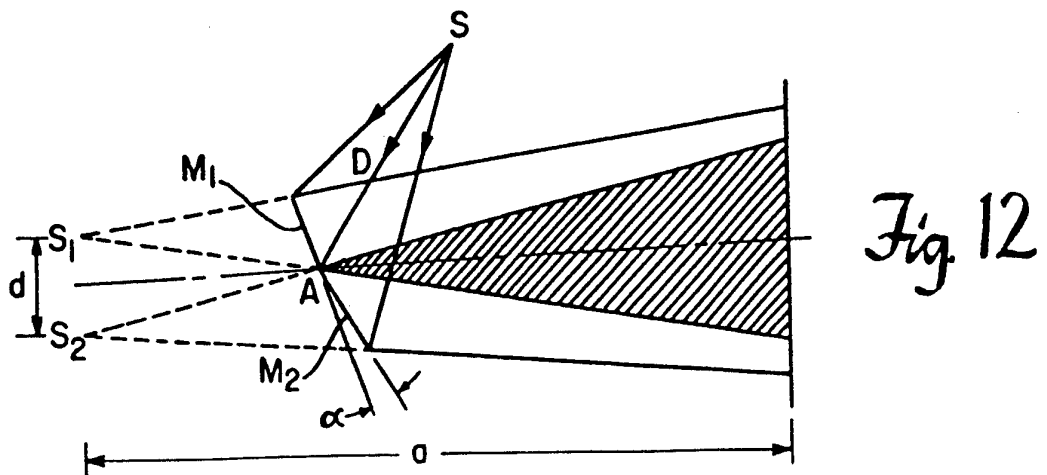
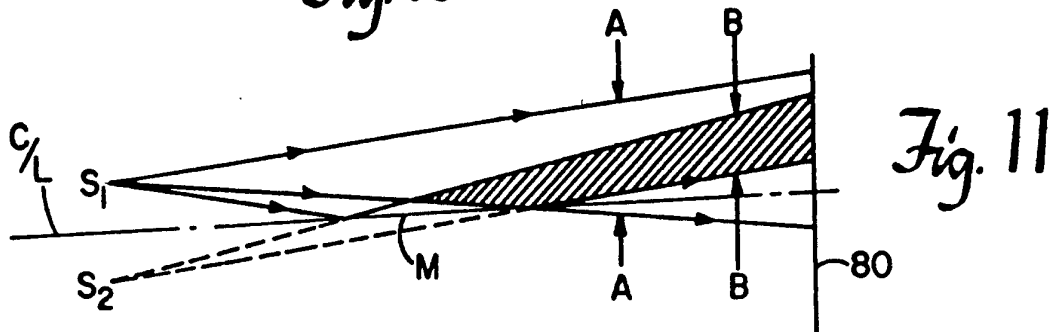
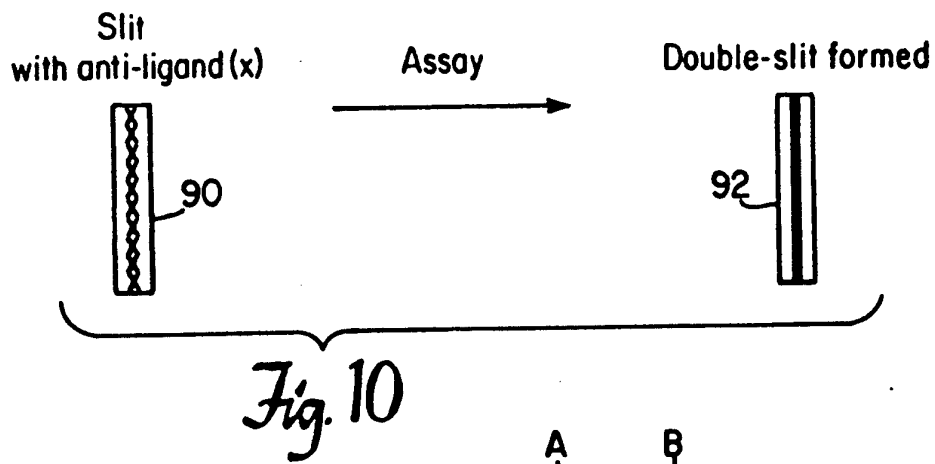
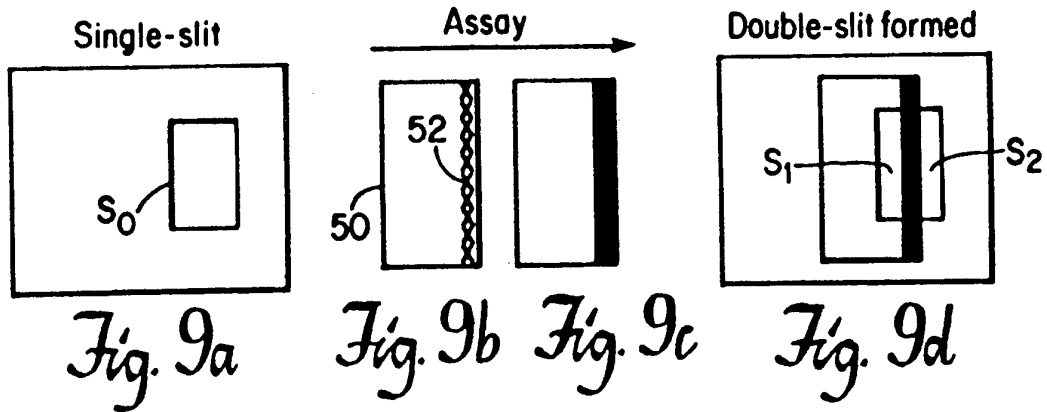

Fig. 8



10/12

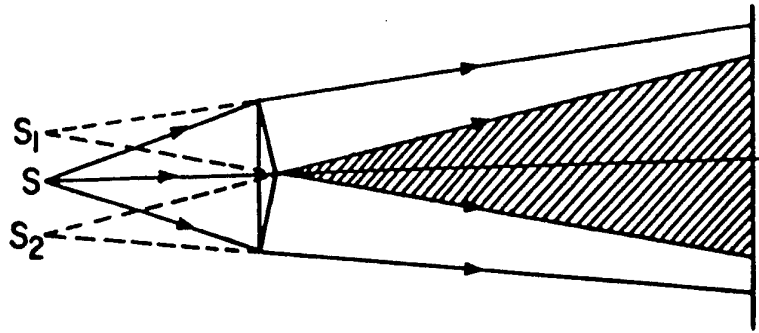

Fig. 13

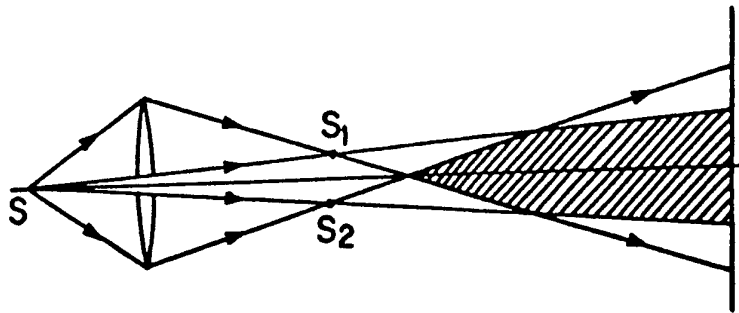

Fig. 14

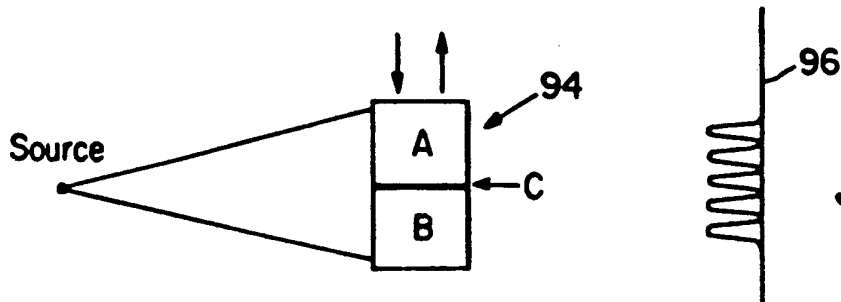

Fig. 15

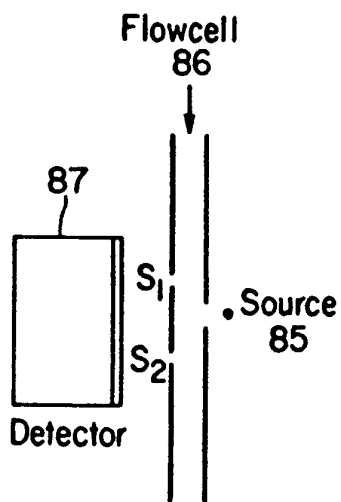

Fig. 16

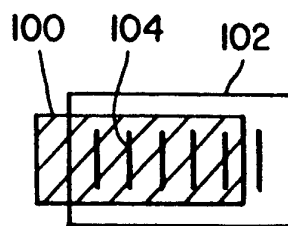

Fig. 17

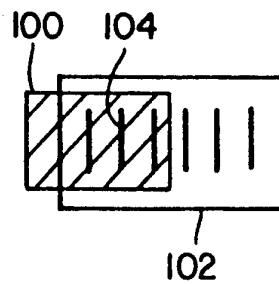

Fig. 18

11/12

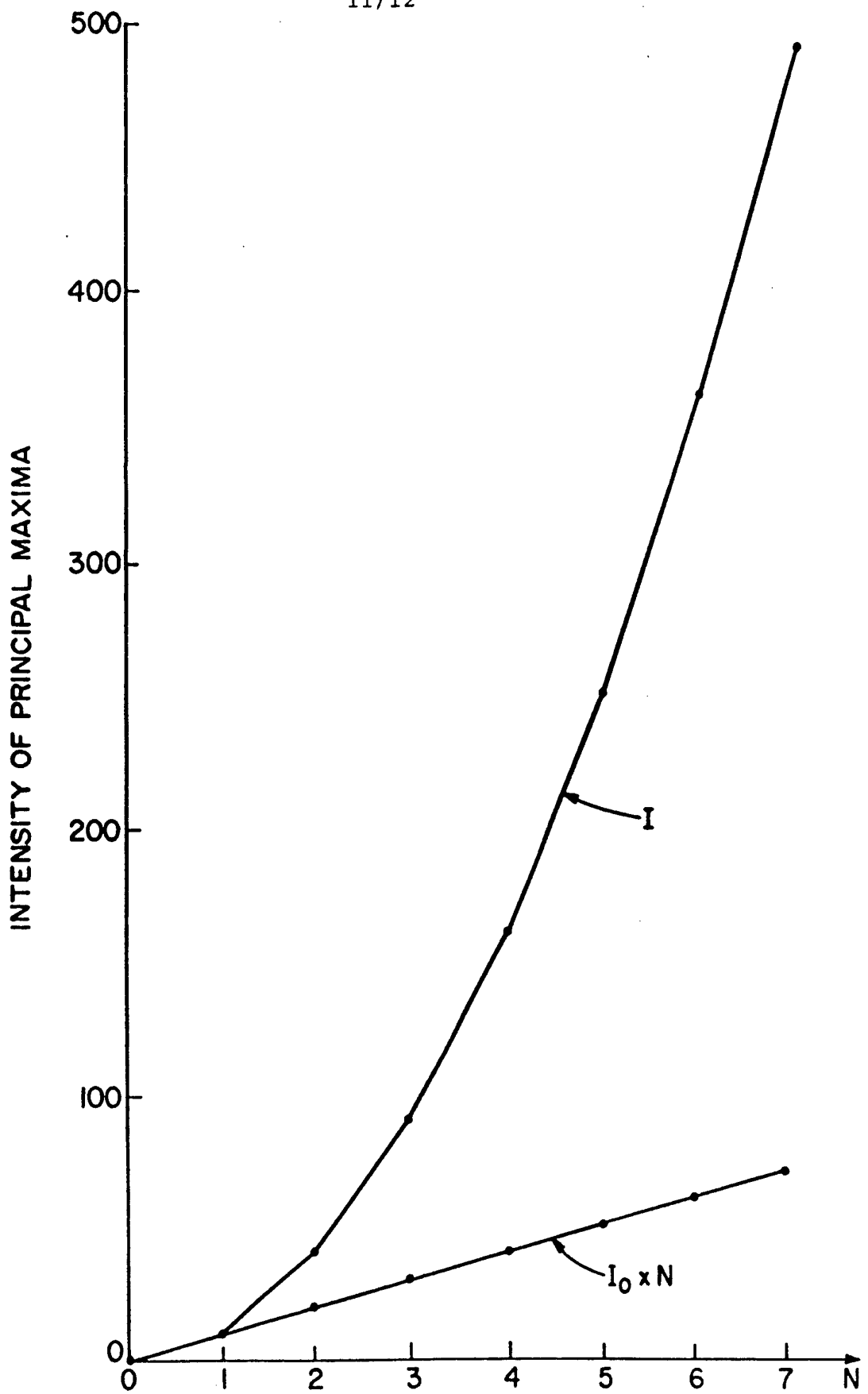

Fig. 19

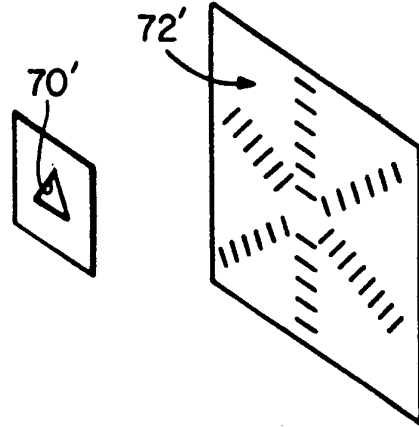
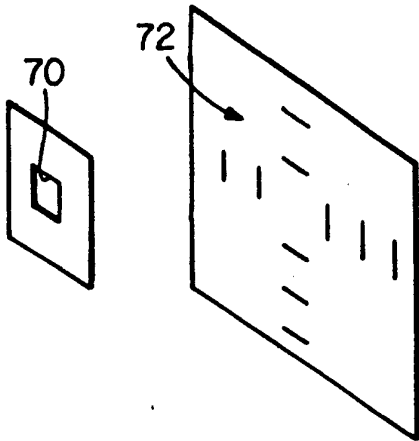
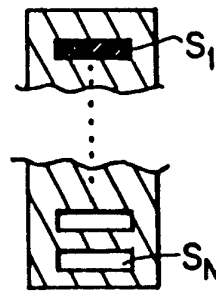
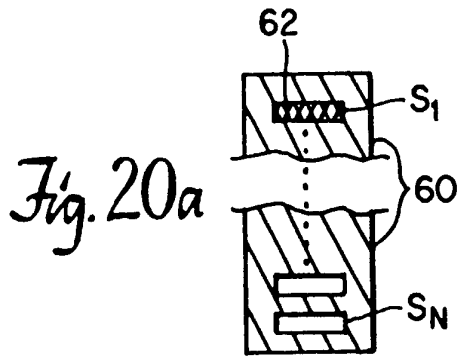

Fig. 21a

Fig. 21b

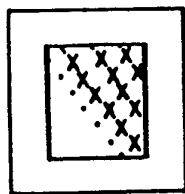

Fig. 21c

assay →



Fig. 21d

INTERNATIONAL SEARCH REPORT

International application No.
PCT/US92/10072

A. CLASSIFICATION OF SUBJECT MATTER

IPC(5) :G01N 33/58, 33/557

US CL :436/501, 517

According to International Patent Classification (IPC) or to both national classification and IPC

B. FIELDS SEARCHED

Minimum documentation searched (classification system followed by classification symbols)

U.S. : 436/501, 517

Documentation searched other than minimum documentation to the extent that such documents are included in the fields searched

Electronic data base consulted during the international search (name of data base and, where practicable, search terms used)

APS, CAS ONLINE, DIALOG

C. DOCUMENTS CONSIDERED TO BE RELEVANT

Category*	Citation of document, with indication, where appropriate, of the relevant passages	Relevant to claim No.
<u>X</u> Y	US, A, 4,621,063 (WYATT ET AL) 04 NOVEMBER 1986, see entire document.	1, 3-4, 7, 10-11, 15-19, <u>25-26</u> 2, 5, 8-9, 12-14, 20-24, 27-37
<u>X</u> Y	US, A, 4,647,544 (NICOLI ET AL) 03 MARCH 1987, see entire document.	<u>1-20, 23-37</u> 21-22
A	US, A, 4,487,839 (KAMENSKY) 11 DECEMBER 1984.	3-4, 18-19, 25, 26, 31, 33, 35-37
A	US, A, 4,889,427 (VAN VEEN ET AL) 26 DECEMBER 1989.	28
A	WO, A, 91/13353 (ISMAIL) 05 SEPTEMBER 1991.	30
A	Proceedings of Society of Photo-Optical Instrumentation Engineers, Vol. 1368, issued 1990, Bioarski et al, "Intergrated optic device for biochemical sensing", pages 264-272.	29-30

Further documents are listed in the continuation of Box C. See patent family annex.

* Special categories of cited documents:	"T" later document published after the international filing date or priority date and not in conflict with the application but cited to understand the principle or theory underlying the invention
"A" document defining the general state of the art which is not considered to be part of particular relevance	"X" document of particular relevance; the claimed invention cannot be considered novel or cannot be considered to involve an inventive step when the document is taken alone
"E" earlier document published on or after the international filing date	"Y" document of particular relevance; the claimed invention cannot be considered to involve an inventive step when the document is combined with one or more other such documents, such combination being obvious to a person skilled in the art
"L" document which may throw doubt on priority claim(s) or which is cited to establish the publication date of another citation or other special reason (as specified)	"g" document member of the same patent family
"O" document referring to an oral disclosure, use, exhibition or other means	
"P" document published prior to the international filing date but later than the priority date claimed	

Date of the actual completion of the international search

16 FEBRUARY 1993

Date of mailing of the international search report

26 FEB 1993

Name and mailing address of the ISA/
Commissioner of Patents and Trademarks
Box PCT
Washington, D.C. 20231

Facsimile No. NOT APPLICABLE

Authorized officer

DILIP P. PANDYA

Telephone No. (703) 308-0196