

(No Model.)

S. L. CAMPBELL.
ELECTRIC ARC LAMP.

No. 525,735.

Patented Sept. 11, 1894.

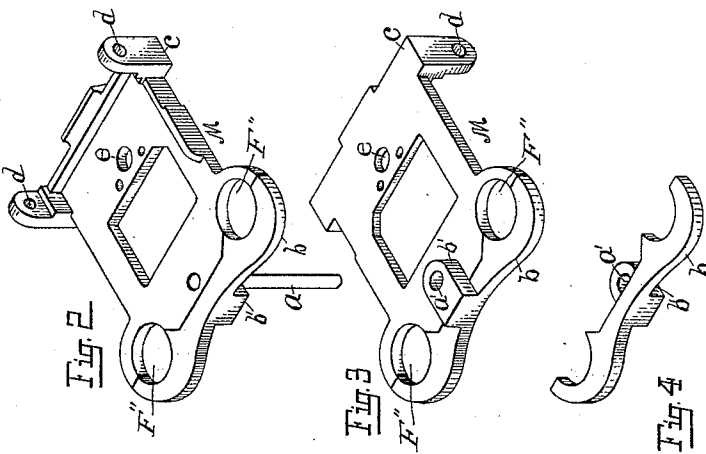
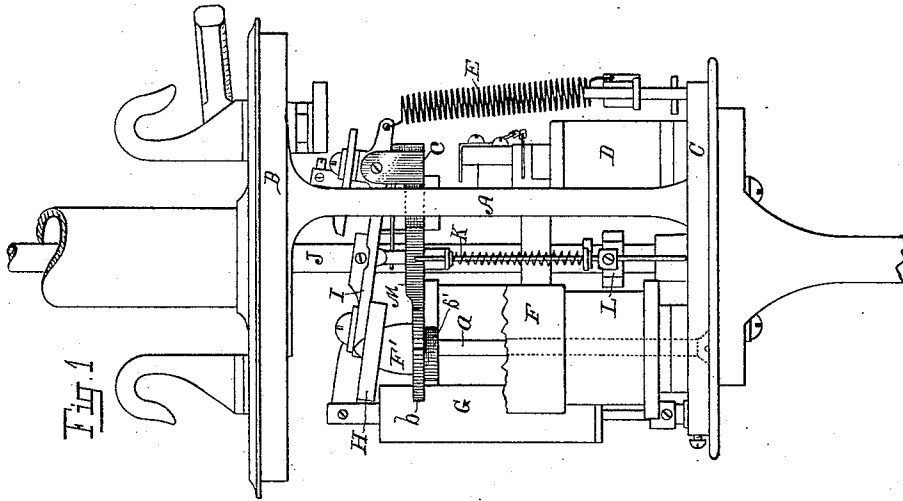

Witnesses:

Walter S. Hood
Wm. C. Hill

Inventor.

Stewart L. Campbell
By *Spud L. Chappell*
Att'y.

UNITED STATES PATENT OFFICE.

STEWART L. CAMPBELL, OF KALAMAZOO, MICHIGAN, ASSIGNOR OF ONE-HALF TO HENRY W. ROOD, OF SAME PLACE.

ELECTRIC-ARC LAMP.

SPECIFICATION forming part of Letters Patent No. 525,735, dated September 11, 1894.

Application filed January 23, 1894. Serial No. 497,743. (No model.)

To all whom it may concern:

Be it known that I, STEWART L. CAMPBELL, a citizen of the United States, residing at the city of Kalamazoo, in the county of Kalamazoo and State of Michigan, have invented certain new and useful Improvements in Arc Lamps, of which the following is a specification.

My invention relates to electric arc lamps, particularly the controlling mechanism of said lamps, and more particularly to the rocker frame in the controlling mechanism.

The objects of my invention are, first, to provide a mechanism that can be easily put together and taken apart; and, second, to provide a lamp mechanism in which parts can be removed for repairs without disturbing the adjustment of the remaining parts. I accomplish these objects by the mechanism shown in the accompanying drawings, in which—

Figure 1, is a side elevation of the controlling mechanism of an arc lamp embodying my invention. Fig. 2 is a view in perspective of the rocker frame with a portion of its bolt attached. Fig. 3 is a perspective view of the same inverted. Fig. 4 is a perspective view of a part of the rocker frame.

Similar letters of reference refer to similar parts throughout the several views.

Fig. 1, is the general view of the controlling mechanism in its frame; above it appears the chimney for the passage of the carbon rod J, which is necessary, and just below the mechanism the lamp globe is situated. It is thus seen, that it is very desirable to have all of the parts compact. The mechanism shown is of a lamp now in common use, and manufactured by the Thomson-Houston Electric Company. It accomplishes its work in a very satisfactory manner. This lamp as heretofore constructed has been difficult to repair for the reason that it has not been convenient to get at the internal working parts, without taking the entire lamp to pieces, which is clearly difficult. Again, a very common accident with these lamps is the burning out of one of the combination coils F. With the lamp as heretofore constructed to replace one of these coils it has been necessary to remove the entire rocker frame M; because of the projecting points F' of the coils F projecting

through apertures F'' in the rocker frame. It will be readily seen that to do this with a rocker frame made of a single piece it is necessary to remove the rocker I, detach the spring E, and remove all the various parts and disconnect them, which of necessity throws the parts out of adjustment, such as the clutch at L, the spring K, and so on. My invention accomplishes the result of making these combination coils F, easily removable and thus enables a workman to easily replace the injured ones, and also gives easy access to the inner parts of the lamp and does not disturb the adjustment. The particular change that accomplishes this result is in the construction of the rocker frame M. This rocker frame is divided into two parts *b* and *c* as shown in Figs. 2 and 3. The part *b*, has a lug *b'*, near the center of its under side, which projects under the center of the front side of part *c*. Bolt *a*, passes up from the bottom C of the main frame through the perforation *a'*, of lug *b'*, into the rear part *c* and so holds both parts securely together, and retains the coils F as securely in place as though the rocker frame M was composed of a single piece. The number of parts and the complexity of the whole, makes this bolt *a* the most convenient means to secure the parts in place.

In repairing the lamp that contains my improvement the dash pot G is detached from the rocker I above when it can be swung down out of the way. The screw *a* is then loosened and the front part *b* of the rocker frame removed, when either or both of the coils F can be slipped out or in and the inner part of the lamp be adjusted with ease. The removal of the coils F in this way does not disturb or destroy the adjustment in the least.

I desire to say that a lamp embodying my invention can be considerably varied in relation to this rocker frame without departing from my invention.

It would be possible to divide the front part of the rocker frame in other directions and accomplish the result. It might be divided into more than two pieces also. The lamp would answer its purpose very well if the front part *b* was entirely dispensed with, and the clamping of the combination coils F, be-

tween the rocker frame and the lower part of the main frame was depended on to secure the coils. It would be desirable to retain a portion of what would be the apertures F'', if the part was whole and passed around the top ends F^c of the coils to guide them to their places and retain them there.

Having thus described my invention, what I claim as new, and desire to secure by Letters Patent, is—

1. In an arc lamp of the class described, the rocker frame, M, consisting of a part, c, in combination with a part, b, having the lug, b', with aperture, a', secured together by bolt, a, so as to form the opening, F'', for points, F', substantially as described for the purpose specified.

2. In an arc lamp, the combination of the rocker frame divided on lines through the openings, F'', the combination magnets, F, with their poles, F', and suitable means of retaining the parts together, for the purpose specified.

3. In an arc lamp, the rocker frame composed of a rear stationary piece fixed in the mechanism, and a forward detachable piece adapted to be separated from the rear part to remove the combination coils, and suitable means of retaining the parts together so that the front portion of the rocker frame can be readily removed in renewing the combination coils and afford convenient means of reaching the inner parts of the lamp, for the purpose specified.

4. In an arc lamp, the rocker frame composed of two pieces formed by a division through the apertures, F'', which embrace the points, F', of the combination coils, and suitable means of retaining the pieces together, for the purpose specified.

In witness whereof I have hereunto set my hand and seal in the presence of two witnesses.

STEWART L. CAMPBELL. [L. S.]

Witnesses:

WALTER S. WOOD,
ADELBERT D. HARRIS.