

L. A. CARPENTER & R. MIDDLETON.  
 SPRINKLING DEVICE.  
 APPLICATION FILED DEC. 23, 1910.

998,232.

Patented July 18, 1911.

*Fig. 1.*

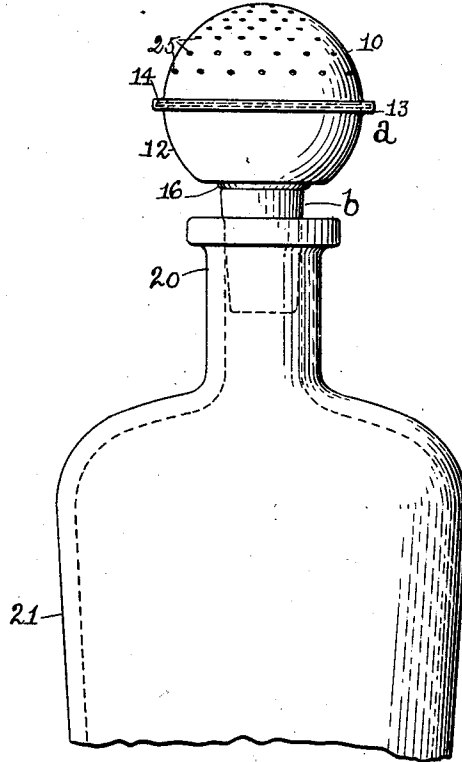

*Fig. 2.*

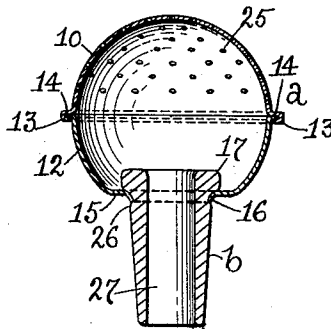

*Witnesses:*  
 M. S. Crozier  
 J. Murphy

*Inventors:*  
 Lewis A. Carpenter  
 Richard Middleton  
 by Jas. H. Churchill  
 Atty.

# UNITED STATES PATENT OFFICE.

LEWIS A. CARPENTER AND RICHARD MIDDLETON, OF REVERE, MASSACHUSETTS.

SPRINKLING DEVICE.

998,232.

Specification of Letters Patent. Patented July 18, 1911.

Application filed December 23, 1910. Serial No. 598,913.

To all whom it may concern:

Be it known that we, LEWIS A. CARPENTER and RICHARD MIDDLETON, citizens of the United States, residing in Revere, county of Suffolk, and State of Massachusetts, have invented an Improvement in Sprinkling Devices, of which the following description, in connection with the accompanying drawings, is a specification, like letters on the drawings representing like parts.

This invention relates to a sprinkling device especially designed and adapted to be used for sprinkling clothes.

The invention has for its object to provide a simple, efficient and inexpensive device, which is capable of being used with a bottle or other receptacle for water.

Figure 1 is an elevation of a sufficient portion of a bottle provided with a sprinkler device or attachment embodying this invention, and Fig. 2, a central vertical section of the sprinkler device removed from the bottle.

The sprinkler device comprises as herein shown a hollow metal head *a* and a hollow stopper *b* attached thereto. The hollow head *a* is composed of two parts or members 10, 12, preferably substantially semi-spherical in shape as herein shown, and united together liquid-tight by turning a flange or rim 13 on the upper member 10 under a flange or rim 14 on the lower member 12 as clearly shown in Fig. 2. The lower member 12 is provided as herein shown with a substantially flat bottom portion 15 having a hole or opening formed in it for the passage through it of the hollow stopper *b*, the said opening being provided with conical walls 16, which extend outwardly and which cooperate with the outer surface of the hollow stopper to lock the latter against inward movement into the hollow head. The stopper *b* may and preferably will be provided within the hollow head with a flange or head 17 of larger diameter than the opening in the bottom 15 so as to form a lock for the stopper against outward movement. The stopper *b* may be of any suitable compressible material, preferably rubber, and is designed to be fitted into the neck 20 of a bottle or other receptacle 21 for water or other fluid employed for sprinkling clothes. The upper member 10 is provided with substantially small perforations 25 forming outlets for the water.

In practice, the stopper *b* is inserted

through the hole or opening in the bottom of the lower member 12 before the upper member 10 is secured thereto as above described, and when the device is thus assembled, it can be used with any bottle having a neck of the proper size to receive the stopper *b*.

In operation, the bottle is filled with water or other fluid and the stopper *b* is then fitted tight into the neck of the bottle, after which the apparatus is ready to be used to sprinkle the clothes or other objects, to do which it is only necessary to invert the bottle and shake the same in a manner well understood.

The stopper *b* is made of slightly larger diameter than the lower end or mouth of the opening in the bottom of the lower member 12, so as to require a slight pressure to force the stopper through the said opening, and thereby compress the stopper sufficiently to cause it to expand after it has passed through the opening and thereby form a locking shoulder 26, which is engaged by the edge of the conical walls 16 of said opening. The stopper *b* is made hollow or is provided with a central bore 27 for the passage of the fluid from the bottle into the hollow head.

The device herein shown is simple, inexpensive and efficient in operation.

Claims.

1. A sprinkling attachment for bottles and like receptacles, comprising a hollow head composed of an upper member provided with perforations, a lower member secured to said upper member and provided with an opening having outwardly extended conical walls, and a hollow stopper of compressible material extended through said opening and provided within the lower member with a head of larger diameter than the said opening and having its upper end compressed by the walls of said opening to form a liquid-tight joint therewith, for the purpose specified.

2. A sprinkling attachment for bottles and like receptacles, comprising a hollow head composed of an upper member provided with perforations, a lower member secured to said upper member and provided with an opening, and a hollow stopper extended through said opening and having its upper end compressed by the walls of said opening to form a liquid tight joint therewith, and means to secure said hollow stopper in fixed relation to said hollow head, substantially as described.

3. A sprinkling attachment for bottles and like receptacles, comprising a hollow head composed of a substantially semispherical upper member provided with perforations, 5 and a substantially semispherical lower member having a substantially flat bottom provided with an opening having outwardly extended walls, means to secure said members together, and a hollow stopper of com- 10 pressible material extended through said opening and provided within the said lower member with a head of larger diameter than the said opening, said stopper on the outside of the hollow head being expanded into 15 locking engagement with the walls of said opening, substantially as described.

4. A sprinkling attachment for bottles and like receptacles, comprising a hollow head composed of an upper member provided 20 with perforations and having an outwardly

extended flange, a lower member provided with an opening in its bottom and at its upper end with an outwardly extended rim or flange, the rim or flange on one member being folded over and embracing the flange 25 on the other member, and a hollow stopper extended through the hole in the bottom of the lower member, and having its upper end compressed by the walls of said opening to form a liquid-tight joint therewith, substan- 30 tially as described.

In testimony whereof, we have signed our names to this specification in the presence of two subscribing witnesses.

LEWIS A. CARPENTER.  
RICHARD MIDDLETON.

Witnesses:

J. H. CHURCHILL,  
J. MURPHY.

Copies of this patent may be obtained for five cents each, by addressing the "Commissioner of Patents, Washington, D. C."