

C. B. DONALDSON.
FLOUR PACKING BIT.

No. 523,977.

Patented Aug. 7, 1894.

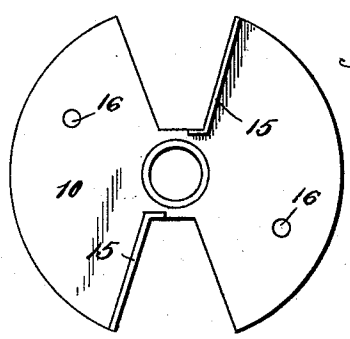
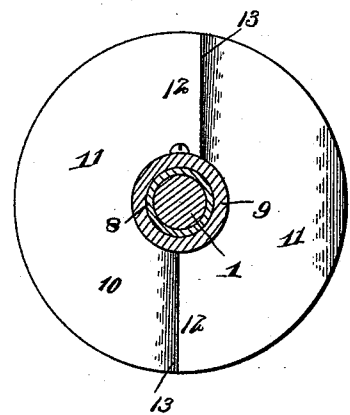
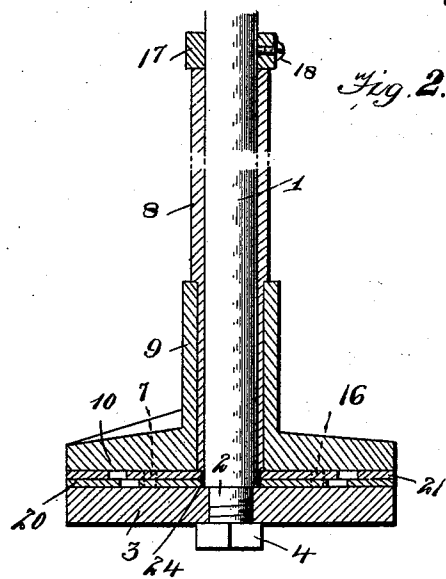
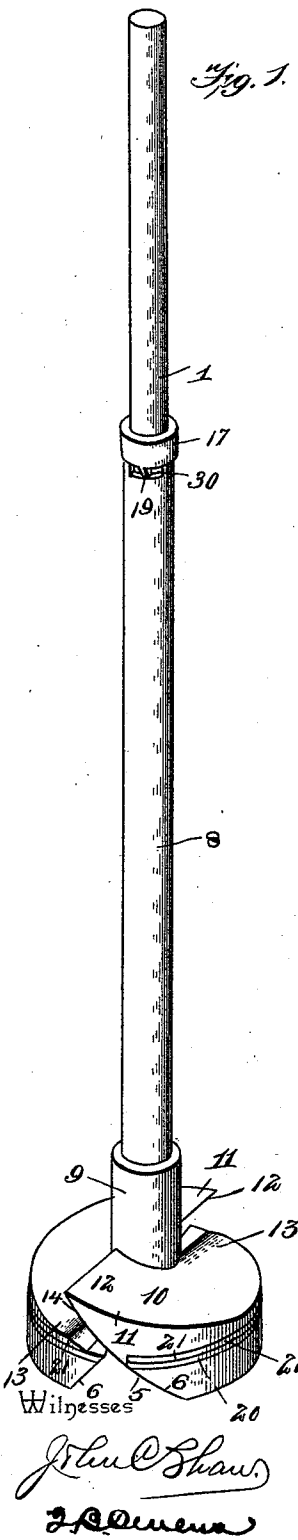

Witnesses
John Shaw
J. J. Owens

Inventor
Charles B. Donaldson
 By his Attorneys.
C. A. Snow & Co.

C. B. DONALDSON.
FLOUR PACKING BIT.

No. 523,977.

Patented Aug. 7, 1894.

Fig. 5.

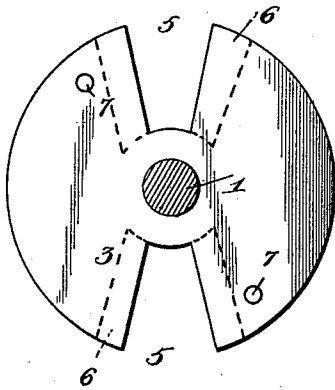

Fig. 6.

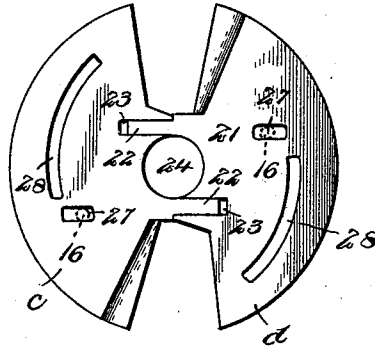

Fig. 7.

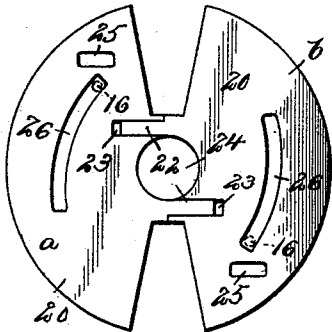

Fig. 8.

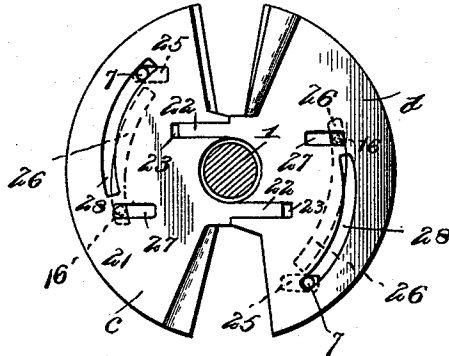

Fig. 9.

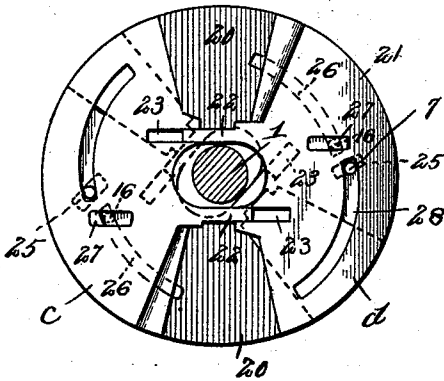
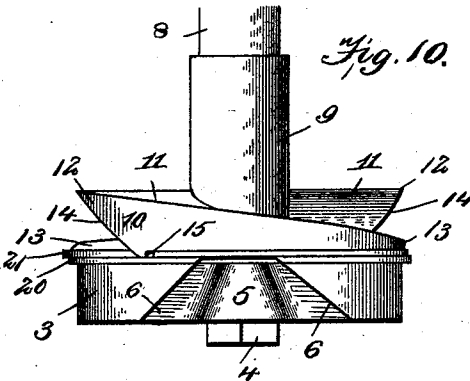

Fig. 10.



Inventor

Witnesses

John C. Shaw.
J. B. Owens.

Charles B. Donaldson,

By *his* Attorneys.

C. A. Snow & Co.

UNITED STATES PATENT OFFICE.

CHARLES B. DONALDSON, OF WILMINGTON, OHIO.

FLOUR-PACKING BIT.

SPECIFICATION forming part of Letters Patent No. 523,977, dated August 7, 1894.

Application filed May 4, 1894. Serial No. 510,087. (No model.)

To all whom it may concern:

Be it known that I, CHARLES B. DONALDSON, a citizen of the United States, residing at Wilmington, in the county of Clinton and State of Ohio, have invented a new and useful Flour-Packing Bit, of which the following is a specification.

This invention is specifically related to those devices designed for use in the usual flour-packing tubes, and to assist in or perform the operation of packing the flour. The principle of these devices is that of the screw or feathering blades, and they are usually arranged to operate positively on the flour at one stage of the operation, when packing, and to subsequently change to allow the flour to pass when more is introduced into the tube.

My invention consists of an improvement on the construction of these devices whereby they are made to more effectually open and close the passage in the tube, and these improvements will be fully described hereinafter and finally embodied in the claims.

In the accompanying drawings: Figure 1 represents a perspective view of a packing bit constructed after the manner of my invention and shown open; Fig. 2, a vertical section of the same; Fig. 3, a cross-section taken just above the body-portion and looking downward; Fig. 4, a bottom plan of the upper body-plate; Fig. 5, a top plan of the lower body-plate; Fig. 6, a plan view of the two sections comprising the upper expansible plate; Fig. 7, a plan view of the two sections comprising the lower expansible plate; Fig. 8, a view showing the top body-portion removed and the expansible plates in the position they would assume when the bit is open; Fig. 9, a similar view with the expansible plates shown in the position assumed when closed; Fig. 10, a side elevation of the device when closed.

1 indicates a shaft, which is adapted to be mounted on the packing machine so as to be incapable of all movement, and which has its lower end reduced at 2, so as to adapt it for the reception of the lower body-plate 3. This plate 3 is circular in general shape and provided with a central orifice adapted to fit over the reduced end 2 of the shaft 1, a nut 4 being provided, whereby the plate 3 is held in place.

The plate 3 is formed with two radial notches 5, therein, which notches taper from their inner ends to the periphery of the plate, and is formed with the downwardly and outwardly inclined sides 6. The sides 6 form flaring openings in the lower side of the plate 3, and these follow the contour of the notches 5, and are for a purpose hereinafter described.

Rigidly secured to or formed integral with the upper face of the plate 3, and arising vertically therefrom, are the studs 7, which are two in number, and one for each of the notches 5, they being arranged on opposite sides thereof.

8 indicates a second shaft, which is hollow throughout its length and adapted to fit snugly over the shaft 1 so as to be capable of independent rotary movement thereon. This shaft has its lower end reduced in size, and such end is adapted for the reception of the sleeve 9, to which the upper body-plate 10 is rigidly secured or formed integral therewith, and which is so related to the shaft 8 that it will lie flush with the end thereof. The upper body-plate 10 is also circular in shape and of a diameter equal to that of the plate 3, and is formed with a plane lower face, while the upper face is formed with two oppositely-inclined faces 11, each having a high end 12, gradually inclined down to the lower end 13, which latter end merges into or communicates with the plane lower face of the plate, forming two radial edges on the lower face.

The high ends 12 of the faces 11 terminate well over the ends 13 of the companion faces, and communicate with the inclined surface 14, extending diagonally downward and to the right to the lower face of the plate, with which face it communicates. The lower ends of the inclined surfaces 14 extend slightly below the plates 10, and thence back, forming the shoulders 15, which are, of course, two in number and extend in the line of a tangent from the central opening in the plate 10 to the periphery thereof. By this construction the plate 10 will be formed with two diagonally and radially disposed notches, which are formed on opposite sides and adapted to match with the notches 5 of the plate 3, as will be better described hereinafter.

Formed integral with, or rigidly secured to, the under surface of the plate 10, and projecting downward therefrom, are the two vertical studs 16, which are arranged one adjacent to each of the openings in the plate 10, and so that they will be located on the sides of the openings 5, which sides are opposite the sides of notches 5 occupied by studs 7. These studs 16 are of a length equal to that of studs 7, and by means of the four studs the two plates are held the requisite distance apart. The shaft 8 is adapted to have a partial rotary movement imparted to it, while the shaft 1 is held stationary; and to properly limit the movements of the shaft 8 the collar 17 is provided and secured to the shaft 8 by means of the set-screw 18. Formed on the under side of the collar 17, and depending downwardly therefrom, is the stud 19, which is adapted to fit into the slot 30 of the upper end of the shaft 8, and thereby prevent the shaft 8 from moving beyond the limit of the slot.

The expansible plates 20 and 21 are two in number and are each formed of two sections, joined by the tongues 22, and slots 23, and provided with matching semi-circular openings 24, which form circular openings in each plate, by which openings the shaft 1 is received. The aggregate thickness of the two plates 20 and 21 is equal to the length of the studs 7 and 16, so that all the space between the plates 3 and 10 will be filled by the plates 20 and 21, while the latter plates are of a diameter equal to that of the body-plates so that they will, when closely engaged, lie within the periphery of the body-plates. Each of the sections of the plates 20 and 21 are so formed that when assembled they will form two oppositely-arranged slots extending radially from the center of the plates and tapering from their inner to their outer ends. These slots match with the notches 5 of the plate 3, and the edges of the plate 20, which edges are formed by the slots therein, are inclined downwardly and outwardly so as to form a continuation of the inclined sides of the notches 5.

The sections of the plates 20 are lettered respectively *a* and *b*, while the sections of the plate 21 are lettered *c* and *d*. The plate 20 is arranged to lie directly adjacent to the lower body plate 3, and have formed therein the short slots 25, which are one for each of the studs 7, and adapted respectively for their reception, whereby the two sections, *a* and *b*, are allowed a limited movement laterally toward and from each other.

The slots 25 are, as will be readily seen, arranged one adjacent to each of the slots in the plate 20, and on opposite sides of their respective notches. This arrangement will necessarily result in one slot being formed on the section *a* and the other slot on the section *b*.

Formed in the sections *a* and *b* of the plate 20 are the eccentric slots 26, which extend in

the arc of a circle, and have their axes eccentric to that of the plate 20. One end of each of the slots 26 is arranged directly adjacent to the slots 25 of their respective sections, while the slot extends outwardly and toward the center of the section, terminating nearer the periphery of the plate than the termination of the first-described end.

The slots 26 are adapted respectively for the reception of the studs 16 of the body-plate 10, and these studs lie normally in the ends of the slots 26, which are nearest the periphery of the plate 20, so that when the plate 10 revolves, as it does and as will be better described hereinafter, the studs 16 will traverse the slots 26 and cause the plates, owing to the eccentric arrangement of the slots 26, to move outwardly and away from each other, they being guided by the slots 25 and studs 7.

The plate 21, composed of sections *c* and *d*, is arranged upon the plate 20 and directly under the body-plate 10, and the sections are so formed that this plate will also have the oppositely-arranged notches therein which are characteristic of the plates 20 and 3, and these notches match with the notches of said plates. One edge of each of the sections *c* and *d*, which edges are formed by the just-described radial notches, is formed perpendicular, and these edges are respectively adapted to lie against the shoulders 15 of the plate 10, and to fit snugly thereagainst. The shoulders 15 are of a thickness equal to that of the plate 21, so that the lower end of the shoulder will be flush with the lower surface of the plate 21. The remaining edges of the sections *c* and *d* (such edges being the companions of the edges just described), are beveled from the upper to the lower side of the plate, and so that they will form continuations of the inclined faces 11 of the plate 10.

Formed in the sections *c* and *d* are the slots 27, which are one for each section, and which are duplicates of the slots 25 aforesaid, the only difference being in the location of the slots 27, said slots being arranged in the ends of sections *c* and *d*, which ends are opposite the ends of sections *a* and *b* which have the slots 25. The slots 27 are arranged so that their outer ends will normally occur directly over and communicate with the ends of the slots 26, which ends are nearest the periphery of the plates 20, and the studs 16 of the plates 8 are adapted to pass through said outer ends of the slots 27, on their way to and into the slots 26, as described.

Each of the sections *c* and *d* are formed with the eccentric slots 28 therein, and these have one end adjacent to the slots 27, and proceed away from them and toward the periphery, terminating at the said ends just over the outer ends of the slots 25 of the plate 20, and adapted to receive, at these ends, the studs 7 of the plate 3, which studs project up from the plate 3 and through slots 25, as aforesaid.

In assembling the parts of my invention

the plate 20 is first arranged on the body-plate 3 and plate 21 next placed over the plate 20 with its several slots in the position just described, after which the body-plate 8 is mounted upon the plate 21, and its studs 16 placed in the proper position.

It will be understood that the positions just described are the normal positions of the parts; those positions which they assume when the device is open, or arranged to allow the flour to pass it. Now, to close the device so that it will close the flour-tube and prevent the passage of flour through it, the shaft 8 is given its characteristic rotary movement, and this in a direction which will cause the studs 16 and 7 to move toward each other. This movement will result in a movement of the sections *c* and *d*, of plate 21, so that slots 28 will traverse their length on studs 7, causing the plates 21, owing to the stationary character of such studs, to move outwardly, and this because of the eccentricity of the slots 28. Concurrently with this operation the studs 16 are moving throughout the slots 26, and toward slots 25, which will cause the sections *a* and *b* to move away from each other, within the limits of the slots 25. It will be noticed that the movement of the plate 20 will be a movement of its sections only, because of the slots 25 and studs 7, which will prevent all unitary movement of the plate 20. On the other hand, the movement of the plate 21 will be both unitary and sectional; or, in other words, the sections *c* and *d* will move away from each other and the whole plate will, because of the connection between slots 27 and studs 16, turn axially for one-quarter of a revolution. This operation will throw the plate 21 over the notches 5, in the body-plate 3, and thereby close said notch, as against vertical passage, and simultaneously spreading the sections 20 so as to enlarge the diameter of the bit. Therefore, the above described turning of the shaft 8 results in a two-fold operation: in the closing of the notches 5, and consequently all passage which otherwise existed through the device, and in a circumferential enlargement of the bit. Upon reversing the shaft 8, studs 16 will draw sections *c* and *d* back and cause slots 28 to move in a reverse direction, thereby moving plate 21 from over notches 5, and moving sections *c* and *d* within the periphery of the body-sections 3 and 10. The reverse movement of the shaft 8 will also be followed by a passage of the studs 16 through the slots 26, and a consequent inward movement of sections *a* and *b* of plate 20.

In using the invention the shaft 8 is connected to the driving mechanism whereby it may be given an alternate revolving movement, within the limit of the slot 30, so as to open or close the bit and thereby open and close the flour tube.

This mechanism may be of any class and I do not regard its description as essential to an understanding of my invention.

It will also be understood that the use of the invention is the same as the use of other flour packers or bits, and this also does not require further description.

Having described my invention, what I claim is—

1. A flour packing bit, comprising the combination of a lower body-plate, an upper body-plate mounted above the same, a sectional extension plate mounted on the lower body-plate and having a limited movement of its sections toward and from each other, a second sectional extension plate mounted on the first and a connection between the respective body-plates and sectional plates, whereby upon movement of the body-plates the bit may be enlarged or contracted circumferentially, substantially as described.
2. A flour packing bit, comprising a body, a sectional plate mounted thereon, the sections of said plate being capable of movement toward and from each other, and a connection between the body and sectional plate whereby the sections may be moved and the bit enlarged or contracted circumferentially, substantially as described.
3. A flour packing bit, comprising a body-plate having a stud projecting therefrom, and a plate arranged adjacent to the body-plate and having an eccentric slot therein, said slot being adapted to receive the stud, and one of the two plates being adapted to move independent of the other so as to cause the plate having the slot to move under the influence of its eccentricity, substantially as described.
4. A flour packing bit, comprising the combination of a lower body-plate, a sectional plate arranged thereon the said sections having a limited independent movement, and each having an eccentric slot therein, and an upper body-plate mounted upon the sectional plate and having thereon studs adapted to operate in the slots of the sectional plate, whereby upon revolving the upper body-plate the sections of the sectional plate will be extended and the size of the bit changed circumferentially, substantially as described.
5. A flour packing bit, comprising the combination of a lower body-plate having two studs projecting upwardly therefrom, an extensible plate having two sections each formed with a short approximately radial slot therein and adapted respectively for the reception of the studs of the said body-plate, whereby the sections are allowed a limited movement on the studs, said sections having formed in each and additional to the first slots an eccentric slot, and an upper body-plate mounted on the extensible plate and having two studs thereon, said studs being adapted to be arranged in the eccentric slots of the extensible plate, whereby upon revolving the upper body-plate the sections of the extensible plate will be moved outwardly, substantially as described.
6. A flour packing bit, comprising the com-

5 bination of a lower body-plate having two studs formed thereon, an extensible plate mounted on the lower body-plate and having two sections each with an approximately radial slot therein, adapted respectively for the reception of the studs of the body-plate aforesaid, whereby the sections are allowed a limited independent movement, said sections also having each an eccentric slot therein, a
10 second extensible plate having two sections, each section having a short radial slot therein adapted to communicate with the eccentric slots on the first extensible plate, and each of said sections having an eccentric slot adapted
15 to communicate with the radial slots of the

first extensible plate, and an upper body-plate mounted on the plates aforesaid and having two downwardly-extending studs adapted to fit respectively in the radial slots of the second extensible plate and in the eccentric slots of the first extensible plate, substantially as and for the purpose described.

In testimony that I claim the foregoing as my own I have hereto affixed my signature in the presence of two witnesses.

CHARLES B. DONALDSON.

Witnesses:

W. I. STEUART,
ALFRED M. P. KAY.