

(19) World Intellectual Property Organization
International Bureau



(43) International Publication Date
12 September 2002 (12.09.2002)

PCT

(10) International Publication Number
WO 02/069848 A2

(51) International Patent Classification⁷: **A61F 2/06**

(21) International Application Number: PCT/US02/05782

(22) International Filing Date: 27 February 2002 (27.02.2002)

(25) Filing Language: English

(26) Publication Language: English

(30) Priority Data:
60/273,592 6 March 2001 (06.03.2001) US

(71) Applicant (for all designated States except US): **BOARD OF REGENTS, THE UNIVERSITY OF TEXAS SYSTEM** [US/US]; The University of Texas System, Office of General Counsel, 201 West 7th Street, Austin, TX 78701 (US).

(72) Inventors; and

(75) Inventors/Applicants (for US only): **FELDMAN, Marc, D.** [US/US]; 11 Royal Gardens Road, San Antonio, TX 78248 (US). **BAILEY, Stephen, R.** [US/US]; 3 Village Knoll, San Antonio, TX 78232 (US). **AGRAWAL, C., Mauli** [US/US]; 2215 Pinoak Knolls, San Antonio, TX 78248 (US). **ATHANASIOU, Kyriacos, A.** [US/US]; 2119 MacArthur, Houston, TX 77030 (US).

(74) Agent: **STROZIER, Robert, W.**; 2925 Briarpark Drive, Suite 930, Houston, TX 77042 (US).

(81) Designated States (national): AE, AG, AL, AM, AT, AU, AZ, BA, BB, BG, BR, BY, BZ, CA, CH, CN, CO, CR, CU, CZ, DE, DK, DM, DZ, EC, EE, ES, FI, GB, GD, GE, GH, GM, HR, HU, ID, IL, IN, IS, JP, KE, KG, KP, KR, KZ, LC, LK, LR, LS, LT, LU, LV, MA, MD, MG, MK, MN, MW, MX, MZ, NO, NZ, OM, PH, PL, PT, RO, RU, SD, SE, SG,

[Continued on next page]

(54) Title: METHOD AND APPARATUS FOR STENT DEPLOYMENT WITH ENHANCED DELIVERY OF BIOACTIVE AGENTS

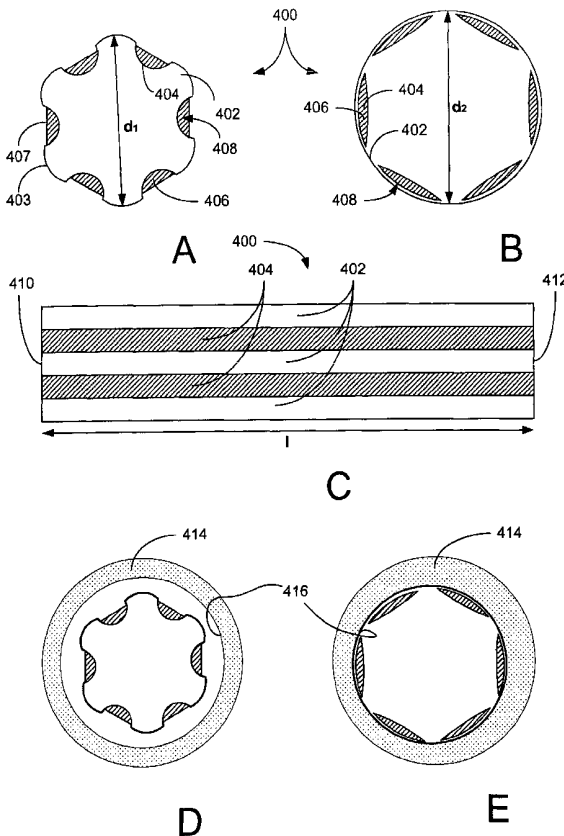

(57) Abstract: A stent for use in animals including humans is disclosed which includes unprotected and protected regions, each protected regions including a bioactive or biopenetrating agent containing therein where the protected regions are protected by the unprotected regions when the stent is in its undeployed state which has a smaller cross-sectional dimension than the stent in its deployed state. And when the stent is in its deployed state the bioactive or biopenetrating agent(s) are brought into direct and intimate contact with a tissue or interior of a blood vessel of an animal including a human.



WO 02/069848 A2



SI, SK, SL, TJ, TM, TN, TR, TT, TZ, UA, UG, US, UZ,
VN, YU, ZA, ZM, ZW.

(84) Designated States (regional): ARIPO patent (GH, GM, KE, LS, MW, MZ, SD, SL, SZ, TZ, UG, ZM, ZW), Eurasian patent (AM, AZ, BY, KG, KZ, MD, RU, TJ, TM), European patent (AT, BE, CH, CY, DE, DK, ES, FI, FR, GB, GR, IE, IT, LU, MC, NL, PT, SE, TR), OAPI patent (BF, BJ, CF, CG, CI, CM, GA, GN, GQ, GW, ML, MR, NE, SN, TD, TG).

Published:

— *without international search report and to be republished upon receipt of that report*

For two-letter codes and other abbreviations, refer to the "Guidance Notes on Codes and Abbreviations" appearing at the beginning of each regular issue of the PCT Gazette.

PATENT SPECIFICATIN

TITLE: METHOD AND APPARATUS FOR STENT DEPLOYMENT
WITH ENHANCED DELIVERY OF BIOACTIVE AGENTS

INVENTOR: Marc D. Feldman, Steven R. Bailey, C. Mauli Agrawal, and
Kyriacos Athanasiou

BACKGROUND OF THE INVENTION

1. Field of the Invention

This invention relates to a stent including indentations having either bioactive agents and/or penetrating structures and/or agents therein or thereon where the indentations protect the agents or structures during stent positioning and where the agents or structures are brought into close proximity to or in contact with a vessel's interior or tissue during stent deployment.

More particularly, this invention relates to a corrugated stent having recessed regions containing bioactive or penetration agents or structures and non-recessed regions, where the agents are protected in the recessed regions. Preferably, the stent undergo a volumeric expansion after deployment, that brings the bioactive or penetration agents or structures into close proximity to or direct contact with a vessel's interior or tissue during deployment.

2. Description of the Related Art

Stents are a valuable medical device designed to maintain pathway of a vessel or maintain or create a tissue cavity in an animal's body in an opened condition. Numerous stents have been described such as those in United States Patent Nos: 5,197,977, 5,282,847, 5,380,299, 5,383,927, 5,464,450, 5,500,013, 5,607,464, 5,624,411, 5,653,745, 5,769,8835, and 5,776,184, incorporated herein by reference. However, these stents lack bioactive or penetrating agents to assist in vessel or tissue healing or deposit digestion, and/or mechanisms for the protection of bioactive or penetrating agents during stent deployment and positioning.

Thus, there is a need in the art for an improved stent having bioactive or penetrating agents deposited thereon in such a way as to protect the agents during

-2-

deployment and placement and capable of bringing the agents into close proximity or direct contact with a vessel's and/or tissue interior after deployment and expansion.

SUMMARY OF THE INVENTION

5 The present invention provides stents for treating, expanding and/or supporting a portion of a vessel or for treating a tissue site, when the stent is inserted into the vessel or tissue site. The stents include at least one or one or more recessed region and at least one or one or more non-recessed region. One or more of the recessed regions can contain: 1) a bioactive composition designed to chemically or biochemically
10 interact with the interior of the vessel or the tissue site to cause a prophylactic and/or therapeutic effect; 2) a penetrating apparatus or structure designed to mechanically or physically interact with the interior of the vessel or the tissue site to cause a prophylactic and/or therapeutic effect; or 3) a mixture or combination thereof. The stents have a deployed and non-deployed state that can be the same or different. In the
15 deployed state, the recessed regions can remain recessed, become essentially flush with the non-recessed regions, protrude above the non-recessed regions and/or include portions that remain recessed relative to the non-recessed regions, protrude above the non-recessed regions or are essentially flush with the non-recessed regions. The term essentially flush means that in the deployed state, the non-recessed and recessed
20 regions form an essentially continuous surface.

 In one preferred embodiment, the stents of the present invention do not change shape after deployment. In another preferred embodiment, the stents of the present invention have an expanded or deployed state and non-expanded or non-deployed state. In the non-expanded or non-deployed state, the stent has a smaller dimension
25 compared to the stent in its expanded or deployed state. The dimension can be a cross-sectional dimension, a length dimension or a combination thereof. When the stent is in its non-expanded or non-deployed state, the non-recessed regions protrude or extend above and protect the compositions and/or structures contained in the recessed regions.

-3-

Moreover, the non-recessed regions are designed to deform, expand and/or elongate to a lesser extent during stent expansion or deployment than the recessed regions. On the other hand, the recessed regions are designed to deform, expand, elongate and/or flatten during deployment. The deformation of the recessed regions during stent deployment can cause the stent to assume a final contour, where the recessed regions are substantially continuous with the non-recessed regions so the all portion of the deployed stent contact the tissue site or surface to approximately the same extent. Alternatively, the stent can deploy so that the recessed regions extend above the non-recessed regions contacting the tissue site or surface to a greater extent than the non-recessed regions. This deformation serves to bring the compositions, structures or combinations or mixtures thereof situated in the recessed regions into close proximity or direct contact with the tissue surface such as the interior of a vessel or the tissue within a tissue site at the site of deployment.

The present invention also provides bioerodible stents of the present invention having the same attributes of the stents disclosed above with the added attribute that the stents themselves will eventually degrade, dissolve, erode, be metabolized or otherwise be gradually removed from the site of implantation.

The present invention also provides a method for treating, expanding or supporting a vessel or other tissue site to achieve a given prophylactic or therapeutic result including the step of positioning a stent of the present invention at a desired site or position in an interior of a vessel or within a tissue in the body of an animal. Once properly positioned, the stent is expanded or deployed forcing the recessed regions to deform, expand, elongate and/or flatten. The deformation of the stent can cause the non-recessed regions and recessed regions to be brought into close proximity or direct contact with the tissue site exposing the tissue site to the compositions and/or structures contained within the recessed regions. Alternatively, the deformation can cause the recessed regions to protrude or extend above the non-recessed regions so that the compositions and/or structures contained within the recessed regions contact the tissue site to a greater extent than the non-recessed region. An ordinary artisan should

-4-

realized that in this embodiment, the recessed regions in the non-deployed state have become the non-recessed regions of the deployed states and *vis-a-versa*. The contact between the stent recessed regions and the tissue site produce a therapeutic and/or prophylactic effect. If the stent is bioerodible, an additional step will be the gradual removal or decomposition of stent itself.

The present invention also provides a method for treating, expanding or supporting a tissue site to achieve a given prophylactic and/or therapeutic result which includes positioning a stent of the present invention at a desired site or position in a tissue of the body of an animal including a human. Once properly positioned, the stent is deployed, thereby forcing the recessed regions to deform, expand, elongate and/or flatten. The deformation of the stent can cause the non-recessed regions and recessed regions to be brought into close proximity or direct contact with the tissue site exposing the tissue site to the compositions and/or structures contained within the recessed regions. Alternatively, the deformation can cause the recessed regions to protrude or extend above the non-recessed regions so that the compositions and/or structures contained within the recessed regions contact the tissue site to a greater extent than the non-recessed region. An ordinary artisan should realize that in this embodiment, the recessed regions in the non-deployed state have become the non-recessed regions of the deployed states and *vis-a-versa*. The contact between the stent recessed regions and the tissue site produce a therapeutic and/or prophylactic effect. If the stent is bioerodible, an additional step will be the gradual removal or decomposition of stent itself.

The present invention further provides methods for making the stents of the present invention.

DESCRIPTION OF THE DRAWINGS

The invention can be better understood with reference to the following detailed description together with the appended illustrative drawings in which like elements are numbered the same:

-5-

Figure 1A is a radial cross-sectional view of a first preferred embodiment of a stent of the present invention in its undeployed state;

Figure 1B is a radial cross-sectional view of the stent of Figure 1A in its deployed state;

5 Figure 1C is a side view of the stent of Figure 1A in its deployed state;

Figure 1D is a radial cross-sectional view the stent of Figure 1A in its undeployed state positioned within a blood vessel;

Figure 1E is a radial cross-sectional view the stent of Figure 1A in its deployed state now engaging an interior of the blood vessel;

10 Figure 2A is a radial cross-sectional view of a second preferred embodiment of a stent of the present invention in its undeployed state;

Figure 2B is a radial cross-sectional view of the stent of Figure 2A in its deployed state;

Figure 2C is a side view of the stent of Figure 2A in its deployed state;

15 Figure 2D is a radial cross-sectional view the stent of Figure 2A in its undeployed state positioned within a blood vessel;

Figure 2E is a radial cross-sectional view the stent of Figure 2A in its deployed state now engaging an interior of the blood vessel;

20 Figure 3A is a radial cross-sectional view of a third preferred embodiment of a stent of the present invention in its undeployed state;

Figure 3B is a radial cross-sectional view of the stent of Figure 3A in its deployed state;

Figure 3C is a side view of the stent of Figure 3A in its deployed state;

25 Figure 3D is a radial cross-sectional view the stent of Figure 3A in its undeployed state positioned within a blood vessel;

Figure 3E is a radial cross-sectional view the stent of Figure 3A in its deployed state now engaging an interior of the blood vessel;

Figure 4A is a radial cross-sectional view of a fourth preferred embodiment of a stent of the present invention in its undeployed state;

-6-

Figure 4B is a radial cross-sectional view of the stent of Figure 4A in its deployed state;

Figure 4C is a side view of the stent of Figure 4A in its deployed state;

5 Figure 4D is a radial cross-sectional view the stent of Figure 4A in its undeployed state positioned within a blood vessel;

Figure 4E is a radial cross-sectional view the stent of Figure 4A in its deployed state now engaging an interior of the blood vessel;

Figure 5A is a radial cross-sectional view of a fifth preferred embodiment of a stent of the present invention in its undeployed state;

10 Figure 5B is a radial cross-sectional view of the stent of Figure 5A in its deployed state;

Figure 5C is a side view of the stent of Figure 5A where the stent is not twisted axially;

15 Figure 5D is a side view of the stent of Figure 5A where the stent is twisted axially into a helical configuration;

Figure 6A is a radial cross-sectional view of a sixth preferred embodiment of a stent of the present invention in its undeployed state;

Figure 6B is a side view of the stent of Figure 6A in its undeployed state;

20 Figure 6C is an axial cross-sectional view the stent of Figure 6A in its undeployed state;

Figure 6D is a radial cross-sectional view of the stent of Figure 6A in its deployed state;

Figure 6E is an axial cross-sectional view the stent of Figure 6A in its deployed state;

25 Figure 7A is a side view of a seventh preferred embodiment of a stent of the present invention in its non-deployed state;

Figure 7B is a side view of the stent of Figure 7A in its undeployed state;

Figure 8A is a radial cross-sectional view of a eight preferred embodiment of a stent of the present invention in it undeployed state;

-7-

Figure 8B is a side view of the stent of Figure 8A in its deployed state;

Figure 9A is a radial cross-sectional view of a ninth preferred embodiment of a stent of the present invention in its undeployed state;

5 Figure 9B is a radial cross-sectional view of the stent of Figure 9A in its deployed state;

Figure 9C is a side view of the stent of Figure 9A in its deployed state;

Figure 9D is a radial cross-sectional view the stent of Figure 9A in its undeployed state positioned within a blood vessel;

10 Figure 9E is a radial cross-sectional view the stent of Figure 9A in its deployed state now engaging an interior of the blood vessel;

Figure 10A is a radial cross-sectional view of a ninth preferred embodiment of a stent of the present invention in its undeployed state;

Figure 10B is a radial cross-sectional view of the stent of Figure 10A in its deployed state;

15 Figure 10C is a side view of the stent of Figure 10A in its deployed state;

Figure 10D is a radial cross-sectional view the stent of Figure 10A in its undeployed state positioned within a blood vessel; and

Figure 10E is a radial cross-sectional view the stent of Figure 10A in its deployed state now engaging an interior of the blood vessel.

20

DEFINITIONS

The term vessel means any vessel or vessel like structure in an animal (including humans) including, without limitation, ureter, airways, pancreatic ducts, biliary ducts, lymphatics, arteries, veins or other vessel type structures in the body.

25 The term animal means any organism that is a member of the animal kingdom including, without limitation, mammals including humans.

The term gradient means a change in some property over a given cross-section of a composition or article. The property can be, without limitation, the concentration of one or more compounds, physical structures, compositional make-up, permeability, porosity, or any other property of a composition or a structure. A gradient can vary

smoothly, can includes one or more peaks, can be vary continuously, discretely or discontinuously across a given cross-section. A gradient peaks when the property has relative maxima in specific regions of the composition or structure across some cross-section.

5

DETAILED DESCRIPTION OF THE INVENTION

The inventors have found that a stent can be constructed that, in its undeployed state, include at least one zone, region, volume or area that protects something deposited in or on, contained in or on, or affixed to or within, positioned in or on, such as, without limitations, bioactive agents or compositions, penetration structures and/or mixtures or combination thereof at least one recessed region of the stent. The compositions and/or structures lie below and are protected by at least one non-recessed region of the stent so that during deployment the compositions and/or structures are protected against contact with the deployment tools or the interior of vessels or tissue sites prior to being properly positioned for final deployment.

Generally, deployment involves dimensional or volumetric expansion of the stent at its site of deployment in a body such as in a vessel or tissue site. The dimensional or volumetric expansion can occur in both the non-recessed and recessed regions to the same or different extent. In a preferred embodiment, the expansion occurs primarily in the recessed regions. The expansion can be radial, axial or a combination of radial and axial. In preferred embodiments, the expansion occurs substantially radial or substantially axial. The expansion causes the recessed regions to become accessible and/or more accessible to the site of deployment so that, in the final stent shape, the composition and/or structures are brought in close proximity to or into direct contact with the site of deployment. The proximity or contact allows the compositions and/or the structures to impart the desired prophylactic and/or therapeutic effect at the site of deployment.

Broadly, the stents of the present invention have an elongate shape, *i.e.*, the stents generally have an axial dimension that is greater then their radial dimension. One unique feature of the stents of the present invention are the presence of at least

one recessed region and one non-recessed region in the stent in its non-deployed state that forms a protected zone or volume in which composition and/or structures can be introduced that will impart a desired prophylactic and/or therapeutic effect at the site of deployment. Preferably, the stent includes a plurality of recessed, non-recessed regions and a plurality of protected regions, zones, areas or volumes into which composition and/or structures can be introduced that will impart a desired prophylactic and/or therapeutic effect to a site of deployment after stent deployment. The recessed and non-recessed regions of the stent form protected zones in the stent. These zone can extend radially, axially or mixtures or combinations of radial or axial zones. The zones are designed to be filled with or contain bio-active compositions and/or structures. The compositions and/or structures can be, without limitation, affixed to the stent in the zones, formed in the zones, deposited in the zones, contained in the zones, or mixtures or combinations thereof.

The stents also have a non-deployed and deployed state, where an overall shape of the stents changes when transitioning from its non-deployed to its deployed state resulting in the deprotection and/or exposure of the compositions and/or structure situated within the recessed regions of the stent. Generally, the shape change involves a volumetric expansion of the stents after deployment, *i.e.*, the volume of the stent in its non-deployed state is smaller than its volume in its deployed state. If the change in volume is primarily due to a radial expansion of the stent, then the radial cross-sectional area of the stent in its non-deployed state is less than its deployed radial cross-sectional area. If the change in volume is primarily due to an axial expansion (elongation), then the length of the stent in its non-deployed state is less than its length in its deployed state. And if the stent expands both radially and axially, then its radial cross-sectional area and length both increase after deployment. However, the stents can also be constructed so that their volume or overall shape remains substantially the same, except that the non-recessed regions of the non-deployed stent become the recessed regions of the deployed stent and *vis-a-versa*.

In one preferred embodiment, the non-recessed regions are more rigid and non-

-10-

deformable than the recessed regions of the stent. In this preferred configuration, the non-recessed regions substantially maintain their shape during stent expansion; while the recessed regions undergo deformation sufficient to deprotect the compositions and/or structures situated within the protected zones allowing the bio-active compositions and/or structures to affect their prophylactic and/or therapeutic effect at the site of deployment after deployment. One simple manufacture process for imparting differential deformation resistances to the recessed and non-recessed regions of a stent is to make the stent thicker at the non-recessed regions than at the recessed regions.

Broadly, the method of deployment of the stents of the present invention includes positioning a stent of the present invention at a desired site in a body of an animal in its non-deployed state and deploying the stent at the site, where deployment causes the stent to undergo a volumetric expansion bringing the compositions and/or structures within the protected regions or zones in close proximity to or into direct contact with the site. If the stent is to be deployed in a vessel, then the method includes forming an opening in the vessel, positioning the stent within the vessel at a desired site, and deploying the stent at that site. If the stent is to be deployed in a tissue or organ, then the method includes forming an opening in the tissue or organ, positioning the stent within the tissue or organ at a desired site, and deploying the stent at that site. Alternatively, the stent can simply be inserted into the tissue or tissue site and deployed. Generally, the stent is first placed or positioned in a medical instrument which maintains the stent in its non-deployed state and allows for positioning of the stent at a desired site within a vessel, tissue or organ of an animal body. One preferred embodiment of this invention relates to an elongated structure having a corrugated radial cross-section including axially disposed peaks (non-recessed regions) and valleys (recessed regions), where the valleys are filled with the compositions and/or structures to a position below the tops of the peaks. Another preferred embodiment includes an elongated structure having a pleated radial cross-section including axially disposed peaks and valleys, where the valleys are filled with the

-11-

compositions and/or structures to a position below the tops of the peaks. In these two embodiments, the peaks and valleys can be disposed in a purely axial fashion or the structure can be twisted so that the peaks and valleys can appear as helices.

5 Another preferred embodiment includes an elongated structure having peaks and valleys disposed radially, where the valleys are filled with the compositions and/or structures to a position below the tops of the peaks.

10 Another preferred embodiment includes an elongated structure that is under tension in its non-deployed state and relaxed in its deployed state, such that the bioactive composition and/or structures are substantially hidden in the non-deployed state and accessible in the deployed state. In this latter embodiment, the hidden or protected regions or zones can be disposed axially or radially.

Moreover, the stent itself can degrade and eventually disappear.

15 In any embodiment, composition including bioactive agents and/or structure including penetrating agents can be situated in the protected zones of the stent. The compositions and/or structures can be situated within the protected regions by, without limitation, coating, adhering, forming, extruding, dipping, deposited in the protected zones. The protected zones or regions can be, without limitation, indentations, valleys, pockets, or the like or mixtures combination thereof. As the stent is inserted inside a vessel, tissue site or organ, these recessed or protected regions are shielded from
20 mechanical removal, abrasion or rubbing due to contact with the vessel(s) and/or tissue during delivery. For use in the heart, the stents are generally delivered via the femoral artery, and normally must traverse plaque laden coronary arteries before they reach the site of deployment. Thus, by placing or situating the bioactive compositions and/or structures within the protected regions of the stent, but below the non-recessed regions
25 of the stent or in regions hidden in the non-deployed state, the loss of bioactive compositions and/or structures during deployment is reduced and an improved delivery of bioactive compositions and/or structures to the site of treatment is achieved.

Once the site of treatment or deployment is reached, the stent is deployed and assumes its deployed shape which may involve a volumetric expansion, radial and/or

-12-

axial, or simply a change in the regions of the stent that are exposed and accessible. If the stent undergoes a volumetric expansion, then such an expansion can occur in all regions of the stent to the same or different extent or can occur primarily in the recessed regions. Regardless, of the final deployed shape of the stent, the final shape or state exposes or further exposes the compositions and/or structures situated in the recessed and brings them in close proximity to or into direct contact with the vessel interior or the tissue at the site of deployment. The penetrating agents or structures are designed to cut, abrade, serrate, break, perforate, puncture and/or penetrate a vessel wall, a plaque deposit in a vessel, a desired structure within a tissue, a tumor, a cyst, or other structure within the body of an animal. The structures can also be designed to dislodge, dissolve, remove and/or eliminated a desired structure within the body of an animal. Examples of penetrating agents can include plaque dissolving chemicals (*e.g.*, collagenase, elastase, *etc.*), and mechanical structures (*e.g.*, metal, plastic, bioerodible polymers, micro or nano electromechanical systems, device or apparatus, nano-structures with biological effects, chemical effects, mechanical effects, electrical effects or mixtures thereof, *etc.*) situated in the protected regions of the stent or mounted within the protected regions of the stent. If the structure is an electromechanical apparatus, system or device, then the structure could undergo oscillatory motion allowing the structure to abrade or grind away a structure such as a plaque deposit. The oscillatory motion could be powered by an internal power source or the structure could include an antenna for absorbing power from an external field similar to the manner in which passive tagging devices are made as described in United States Patent Nos.: 6,192,279; 6,120,460; and 5,820,589, incorporated herein by reference with respect to the electronics needed for external field activation of a remote electromechanical device. If the structure includes an electric field alignable microcrystals such as crystals used in piezoelectric transducers, an oscillatory electric field would cause the crystals to undergo an oscillatory motion to grind or abrade a given structure in the body such as a plaque deposit. The electric field could also cause movement of DNA or proteins off the stent into the tissue since DNA and

-13-

proteins are charged structures. Of course, because electric and magnetic fields are coupled mathematically by Maxwell's equations, magnetic fields can also be used.

5 One preferred agent delivery system involves the use of encapsulated plaque dissolving chemicals. Upon stent deployment, the capsules are designed to rupture and deposit the agents onto the plaque. Another embodiment involves the use of metal or biodegradable structures to penetrate the plaque. These plaque penetrating structures preferably have a profile smaller than the height of the non-recessed areas of the stent and are generally situated in the protected zone near a center of the recessed regions. After deployment, the structures generally extend above the non-recessed regions of the stent so that the structures have a greater opportunity to directly contact or protrude into the plaque. The penetrating structures may be microporous so that the structure can contain drugs, genes or other prophylactic and/or therapeutic agents and may be a micro or nano structures including micro and nano mechanical, electrical, electro-mechanical, *etc.* structures. Another embodiment involves the rapid or gradual release of bioactive agent (drugs, genes, growth factors and/or growth factor inhibitors) through the use of encapsulated beads, biodegradables or other materials situated within the protected regions or contained within the material of the entire stent.

10 The inventors have found that compositions deposited or otherwise situated or positioned in the protected regions or portions of the stents can be any composition provided that the composition is brought into proximity, preferable close proximity, or into contact, preferably direct contact, with a vessel's interior surface or tissue of a tissue site after stent deployment. The term proximity means sufficiently close to a desired site that the composition can impart the desired prophylactic and/or therapeutic effect to the site. The term close proximity means sufficiently close to the desired site that the composition can impart substantially the entire desired effect at or to the desired site.

25 The compositions can have substantially uniform, variable and/or differential permeability and/or porosity and/or height. The compositions can be permeable to bodily fluids in general or to constituents thereof. Moreover, the permeability can vary

-14-

across a desired profile of the composition or throughout the entire composition, *i.e.*, the composition have a permeability gradient across a desired profile of the composition. Additionally, the compositions can have porosities that also vary across a desired profile of the composition or throughout the entire composition, *i.e.*, the composition have a porosity gradient across a desired profile of the composition..

5 Composition permeability (or permeabilities to desired constituents of bodily fluids) can range from essentially or substantially impermeable to highly permeable to bodily fluids in general or to desired constituents of bodily fluids. That is, the compositions may have include gradients of pores (voids), material content, bioactive agents or the

10 like. These gradients can change abruptly as in discontinuous changes in materials, smoothly so the property changes smoothly across a given profile of the composition or peaked where the permeability goes through maxima and minima across the profile.

Preferably, the compositions deposited in the protected zones of the stents of the present invention are encapsulated in an encapsulation matrix which is designed to rupture during stent deployment or bioerode after deployment. The encapsulated

15 compositions can simply be bioactive agents designed to impart a desired prophylactic and/or therapeutic effect on the site where the stent is deployed. The encapsulated compositions can be bioactive agents dispersed in a bioerodible matrix that controls the release of the agents via bioerosion or degradation. The physical structures can

20 also be encapsulated such as sharp crystals, crystalline structures, micro or nano structures, mechanical, electrical, electromechanical devices for penetrating into the interior surface of the vessel or into the tissue of a tissue site. Additionally, the crystals can be electrically or magnetically active so that the application of an oscillating external electric or magnetic field will cause the crystals to undergo alignment and

25 dealingment with the lines of force inducing an abrading action similar to a motion of crystals in piezoelectric transducer. Moreover, the non-crystal structures can be magnetically or electrically active so that they will move in response to an applied external field, *e.g.*, oscillate in response to an oscillating field, turn in response to an external field, or undergo so other motion in response to an applied external field.

-15-

Mixtures or combinations of penetrating mechanical or physical structure (bio or non-bio degradable) and bioactive agents (chemicals, pharmaceuticals, enzymes, genes, or other gene delivery systems such as retroviruses, adenoviruses, viral vectors, plasmids, liposomes containing DNA or RNA or the like) can also be encapsulated so that the mechanical or physical structures will perforate the tissue or the interior surface of the vessel (plaque or vessel wall) improving the availability of the bioactive agents.

The compositions of this invention may further contain other materials such as fillers to improve the strength of the materials such as polymer matrices, materials that will aid in degradation, anti-degradants such as anti-oxidants, biologically-active agents, colorants, chromophores or light activated (fluorescent or phosphorescent) tags or any other material that may alter or change the property of the compositions.

Another preferred form of the compositions and/or structures deposited in the protected regions or portions of the stents of the present invention is to coat the compositions and/or structures with a bioerodible coating. After bioerosion of the coating, the compositions and/or structures can impart their prophylactic and/or therapeutic effect to a vessel or tissue.

Bioactive Agent

Bioactive agents or biologically-active agents which may be used alone or in combination with bioerodible polymers include medicines, pharmaceuticals, drugs, or any suitable biologically-, physiologically- or pharmacologically-active substances which are capable of providing local biological or physiological activity to the interior surfaces of vessels or to tissues of an animal, including a human, and if contained in an erodible polymer or polymer matrix are capable of being released from the polymer matrix into interior or interior surface of vessels such as blood vessels, bile ducts, ureters, pancreatic ducts, *etc.* or into tissues.

If the biologically-active agent(s) are to be added to the polymer composition during preparation, then the agent(s) are not altered by the polymer, the solvent, if one is used or the preparation conditions. Generally, the agents are simply added to the polymer and the mixture is stirred to produce a homogeneous composition and if a

-16-

solvent is used, the solvent is removed by any technique that does not result in the dilution, removal, degradation and/or decomposition of the bioactive agent.

Suitable biologically-active agents also include substances useful in preventing infection at the composition site, as for example, antiviral, antibacterial, antiparasitic, antifungal substances and combinations thereof. The agent may further be a substance capable of acting as a stimulant, sedative, hypnotic, analgesic, anticonvulsant, and the like. The compositions of this invention can contain large numbers of biologically-active agents either singly or in combination. Examples of these biologically-active agents include, but are not limited to: (1) anti-inflammatory agents such as hydrocortisone, prednisone, fludrotisone, triamcinolone, dexamethasone, betamethasone and the like; (2) anti-bacterial agents such as penicillins, cephalosporins, vancomycin, bacitracin, polymyxins, tetracyclines, chloramphenicol, erythromycin, streptomycin, and the like; (3) antiparasitic agents such as quinacrine, chloroquine, quinine, and the like; (4) antifungal agents such as nystatin, gentamicin, miconazole, tolnaftate, undecyclic acid and its salts, and the like; (5) antiviral agents such as vidarabine, acyclovir, ribarivin, amantadine hydrochloride, iododeoxyuridine, dideoxyuridine, interferons and the like; (6) antineoplastic agents such as methotrexate, 5-fluorouracil, bleomycin, tumor necrosis factor, tumor specific antibodies conjugated to toxins, and the like; (7) analgesic agents such as salicylic acid, salicylate esters and salts, acetaminophen, ibuprofen, morphine, phenylbutazone, indomethacin, sulindac, tolmetin, zomepirac, and the like; (8) local anaesthetics such as cocaine, benzocaine, novocaine, lidocaine, and the like; (9) vaccines such as hepatitis, influenza, measles, mumps, rubella, hemophilus, diphtheria, tetanus, rabies, polio, and the like; (10) central nervous system agents such as tranquilizers, sedatives, anti-depressants, hypnotics, B-adrenergic blocking agents, dopamine, and the like; (11) growth factors such as colony stimulating factor, epidermal growth factor, erythropoietin, fibroblast growth factor, neural growth factor, human growth hormone, platelet derived growth factor, insulin-like growth factor, and the like; (12) growth factor inhibitors such as inhibitors for colony stimulating factor, epidermal growth factor, erythropoietin,

-17-

fibroblast growth factor, neural growth factor, human growth hormone, platelet derived growth factor, insulin-like growth factor, and the like; (13) hormones such as progesterone, estrogen, testosterone, follicle stimulating hormone, chorionic gonadotrophin, insulin, endorphins, somatotropins and the like; (14) antihistamines
5 such as diphenhydramine, chlorpheniramine, chlorcyclizine, promethazine, cimetidine, terfenadine, and the like; (15) cardiovascular agents such as verapamil hydrochloride, digitalis, streptokinase, nitroglycerine papaprefine, disopyramide phosphate, isosorbide dinitrate, and the like; (16) bronchodilators such as metaproteral sulfate, aminophylline, albuterol, and the like; and/or (17) vasodilators such as theophylline,
10 niacin, nicotinate esters, amylnitrate, minoxidil, diazoxide, nifedipine, and the like.

As the compositions biodegrades and/or bioerodes, the biologically-active agent may be released from the matrix into the adjacent tissue fluids. The biologically-active agent can be released into the surrounding tissue or bodily fluids at a controlled rate (a biodegradation of a uniform matrix), intermittently (layers of agents and
15 biodegradables), or a delayed time. For example, the polymer matrix may be formulated to degrade after an effective and/or substantial amount of the biologically-active agent is released from the matrix. Release of a biologically-active agent having a low solubility in water, as for example a peptide or protein, may require the degradation of greater amounts of the polymer matrix to expose the agent directly
20 to the surrounding tissue fluids. Thus, the release of the biologically-active agent from the matrix may be varied by, for example, the solubility of the biologically-active agent in water, the distribution of the biologically-active agent within the matrix, or the size, shape, porosity, solubility and biodegradability of the polymer matrix, among other factors.

25 The biologically-active agent may also be a substance or metabolic precursor thereof, which is capable of promoting growth and survival of cells and tissues, or augmenting the activity of functioning cells, as for example, blood cells, neurons, muscle, bone marrow, bone cells and tissues, and the like, especially endothelial cells in the case of vessels in the body. For example, the biologically-active agent may be

-18-

a nerve growth promoting substance, as for example, a ganglioside, phosphatidylserine, a nerve growth factor, brain-derived neurotrophic factor, a fibroblast growth factor, and the like.

To promote tissue growth, the biologically-active agent may be either a hard or soft tissue promoting substance or combinations thereof. Suitable peptides and/or tissue growth promoting agents include, for example, fibronectin (FN), endothelial cell growth factor (ECGF), cementum attachment extracts (CAE), human growth hormone (HGH), a Periodontal ligament cell growth factor, fibroblast growth factor (FGF), animal growth hormones, platelet derived growth factor (PDGF), epidermal growth factor (EGF), protein growth factor interleukin-1 (IL-1), transforming growth factor (TGF beta -2), insulin-like growth factor II (ILGF-II), human alpha thrombin (HAT), osteoinductive factor (OIF), bone morphogenetic protein (BMP) or protein derived therefrom, demineralized bone matrix, and releasing factors thereof.

The biologically-active agent may also be a substance or metabolic precursor thereof, which is capable of inhibiting or retarding growth and/or cell survival or augmenting the activity of functioning cells, especially endothelial cells. The inhibiting biologically-active agents may be either a hard or soft tissue inhibiting substance or combinations thereof. Suitable agents include agents that can interfere with or inhibit the action of fibronectin (FN), endothelial cell growth factor (ECGF), cementum attachment extracts (CAE), human growth hormone (HGH), a Periodontal ligament cell growth factor, fibroblast growth factor (FGF), animal growth hormones, platelet derived growth factor (PDGF), epidermal growth factor (EGF), protein growth factor interleukin-1 (IL-1), transforming growth factor (TGF beta -2), insulin-like growth factor II (ILGF-II), human alpha thrombin (HAT), osteoinductive factor (OIF), bone morphogenetic protein (BMP) or protein derived therefrom, demineralized bone matrix, and releasing factors thereof.

Other suitable bioactive agents include, without limitation, DNA, RNA, or DNA/RNA sequences that encode for proteins involved in NO regulator proteins and/or enzymes, VEFT or any of the other above-identified proteins, enzymes. or the

like. Additionally, the genetic material may include up regulator factors or suppressor factors for changing or augmenting the normal production of certain proteins, enzymes or the like.

Encapsulating Bioactive Agents

5 Suitable encapsulating agents include, without limitation, any encapsulating formation approved for use in the body including all of the biodegradable polymers mentioned previously in connection with bioactive agents. Moreover, photopolymerizable monomers capable of being polymerized *in situ* and to cover the recessed areas. Deployment would then result in the rupturing of the covering.
10 Additionally, starch and sugar based material can be used as an encapsulating covering over the composition and/or structures in the protected zones of the stents of the present invention.

Bioerodible Polymers and Polymeric Compositions

15 Suitable polymers for use in the present invention include, without limitation, biocompatible polymers, preferably biocompatible polymers that are biodegradable and/or bioerodible, *i.e.*, the polymers eventually decompose in the body. The biodegradation and/or bioerodible can be by cellular degradation (*e.g.*, macrophage degradation or the like), chemical degradation (*e.g.*, enzymatic degradation), hydrolysis (*e.g.*, via bodily fluids such as plasma) or other cellular action and/or the degradation
20 or erosion can be due to degradation agents contained within the composition itself (*e.g.*, embedded enzymes, depolymerization agents or the like). Such polymeric substances include polyesters, polyamides, polypeptides and/or polysaccharides or the like.

25 Non-limiting examples of suitable biocompatible, biodegradable polymers, include polylactides, polyglycolides, polyfumarates, polycaprolactones, polyanhydrides, polyamides, polyurethanes, polyesteramides, polyorthoesters, polydioxanones, polyacetals, polyketals, polycarbonates, polyorthocarbonates, polyphosphazenes, polyhydroxybutyrates, polyhydroxyvalerates, polyalkylene oxalates, polyalkylene succinates, poly(malic acid), poly(amino acids), poly(methyl vinyl ether),

-20-

poly(maleic anhydride), chitin, chitosan, and copolymers, terpolymers, or higher polymer monomer polymers thereof or combinations or mixtures thereof. The preferred biodegradable polymers are all degraded by hydrolysis.

Typically, the polymers will either be surface erodible polymers such as polyanhydrides or bulk erodible polymers such as polyorthoesters. Poly(L-lactic acid) (PILA), poly(DL-lactic acid) (PLA), poly(glycolic acid) (PGA), polycaprolactones, copolymers, terpolymer, higher polymer monomer polymers thereof, or combinations or mixtures thereof are preferred biocompatible, biodegradable polymers. The preferred biodegradable copolymers are lactic acid and glycolic acid copolymers sometimes referred to as poly(DL-lactic-co-glycolic acid) (PLG). The co-monomer (lactide:glycolide) ratios of the poly(DL-lactic-co-glycolic acid) are preferably between about 100:0 to about 50:50 lactic acid to glycolic acid. Most preferably, the co-monomer ratios are between about 85:15 and about 50:50 lactic acid to glycolic acid. Blends of PLA with PLG, preferably about 85:15 to about 50:50 PLG to PLA, are also used to prepare polymer materials.

PLA, PILA, PGA, PLG and combinations or mixtures or blends thereof are among the synthetic polymers approved for human clinical use. They are presently utilized as surgical suture materials and in controlled release devices, as well as in other medical and pharmaceutical applications. They are biocompatible and their degradation products are low molecular weight compounds, such as lactic acid and glycolic acid, which enter into normal metabolic pathways. Furthermore, copolymers of poly(lactic-co-glycolic acid) offer the advantage of a large spectrum of degradation rates from a few days to years by simply varying the copolymer ratio of lactic acid to glycolic acid.

To enhance bio-degradation of the polymers used in biological application, the compositions of the present invention can also include the addition of enzymes that can facilitate the biodegradation of the polymers used in the composition. Preferred enzymes or similar reagents are proteases or hydrolases with ester-hydrolyzing capabilities. Such enzymes include, without limitation, proteinase K, bromelaine,

-21-

pronase E, cellulase, dextranase, elastase, plasmin streptokinase, trypsin, chymotrypsin, papain, chymopapain, collagenase, subtilisin, chlostridopeptidase A, ficin, carboxypeptidase A, pectinase, pectinesterase, an oxidoreductase, an oxidase or the like. The inclusion of an appropriate amount of such a degradation enhancing agent can be used to regulate composition duration.

Suitable Solvents for Use in Forming the Bioactive Compositions

Suitable polymers can be combined with suitable organic solvents to form polymeric solutions. The solubility or miscibility of a polymer in a particular solvent will vary according to factors such as crystallinity, hydrophilicity, capacity for hydrogen-bonding and molecular weight of the polymer. Consequently, the molecular weight and the concentration of the polymer in the solvent are adjusted to achieve the desired miscibility and/or viscosity. Preferred polymers are those which have a low degree of crystallinity a low degree of hydrogen-bonding, low solubility in water, and high solubility in organic solvents.

In general, the polymers are dissolved in a suitable organic solvent. The solvent should not adversely affect the polymer or the particulate solids and preferably should be a volatile organic solvent. The relative amount of solvent will have a minimal effect on the structure of the produced materials, but will affect the solvent evaporation time.

Solvents which may be used to make polymeric compositions of the invention include, without limitation, N-methyl-2-pyrrolidone, 2-pyrrolidone, C2 to C6 alkanols, propylene glycol, acetone, alkyl esters such as methyl acetate, ethyl acetate, ethyl lactate, alkyl ketones such as methyl ethyl ketone, dialkylamides such as dimethylformamide, dimethyl sulfoxide, dimethyl sulfone, tetrahydrofuran, cyclic alkyl amides such as caprolactam, decylmethylsulfoxide, oleic acid, propylene carbonate, aromatic amides such as N,N-diethyl-m-toluamide, and 1-dodecylazacycloheptan-2-one. Preferred solvents according to the invention include N-methyl-2-pyrrolidone, 2-pyrrolidone, dimethyl sulfoxide, acetone, and propylene carbonate. Preferred solvents are simple ketones such as acetone, chlorinated

hydrocarbons such as methylene chloride, chloroform, methylethylketone, or the like.

Preferred Stent Materials

Suitable materials that can be used to make the stents of the present invention include, without limitation, iron alloys such as stainless steels, titanium alloys, cobalt
5 chrome alloys, nitinol, platinum-based alloys, gold and gold alloys, silver and silver alloys, polyolefins such as polyethylene, polypropylene, or the like, polyanhydride, polyorthoesters, polyurethane, polyesterurethane, polycaprolactone, polyacetal, polyethylene terephthalate or other polyesters, silicone, siloxanes, polysiloxanes, silicone rubbers, or other like silicone polymers, polylactides/polyglycolides, nylon or
10 other polyamides, polycarbonate, fluorinated polyolefins such as Teflon[®], acrylics such as polymethylmethacrylate, hyaluronic acid, collagens, hydroxyapatite, acellular tissue products, keratan, chitosan, other similar materials or mixtures or combinations thereof. For bioerodible stent, any of the bioerodible materials previously mentioned above can be used. Of course, the exact material should biodegrade at a rate slower
15 to substantially slower than the rate of delivery of bioactive agents and/or structures.

Moreover, the stents may be a mixture of combination of material. Thus, the recessed regions may be polymeric, while the non-recessed regions may be metal; the recessed regions may be composed of a flexible or deformable polymer, while the non-recessed regions may be composed of a non-flexible or non-deformable polymer.

Preferred Materials for Use in the Compositions

The compositions to be situated inside the protected zones of the stents of the present invention are generally any bio-active agent, polymer matrix containing a bio-active agent or an encapsulated bio-active agent or a polymer matrix containing a bio-active agent or mixtures and combinations thereof designed to achieve a given
25 therapeutic and/or prophylactic effect at the site of deployment. The stents can include a single bio-active agent or any number of bio-active agents and compositions to regulate the release of these bio-active agents.

Preferred Materials for Use in the Structures

The structures to be situated inside the protected zones of the stents of the

-23-

present invention are generally any structure designed to achieve a given therapeutic and/or prophylactic effect at the site of deployment. The structures can simply be crystals or other relatively hard compounds or a mechanical, electrical, electromechanical device and may be porous to hold the bioactive agents in large quantities. The crystals, compounds, or devices are generally small and typically range from about 1 nm in height to about 1 mm in height, preferably, from about 5 nm to about 500 μm in height and particularly, from about 50 nm to about 200 μm in height. The devices, compounds or crystals can also include bio-active agents that are delivered to the site of deployment concurrently with the action of the structures or at some time controlled by the structure itself, *e.g.*, rate of degradation of the structures, controlled opening of a cavity, or a composition associated with the structures, where the composition is as set forth above. Additionally structures which can be used in the stents of this invention include the structure set forth in United States Patent Application Ser. No. 6,197,013, incorporated herein by reference.

Preferred Embodiments of the Stents Including Bioactive Agents

Referring now to Figures 1A-B, a first embodiment of a stent **100** of the present invention is shown in cross-section to have a generally triangular cross-section in its un-deployed state and a generally circular cross-section in its deployed state, respectively. The stent **100** includes three convex arcuate, non-recessed regions **102** and three concave recessed regions **104**, where the regions **102** and **104** regions alternate. The stent **100** also includes a bioactive composition **106** deposited in protected zones **108** located in the recessed regions **104**, where the composition **106** outer surface **107** is below an outer surface **103** of the non-recessed areas **102**. The stent's cross-sectional dimension in its undeployed state, as shown in Figure 1A, can be inscribed in a first circle **110** having a first diameter d_1 and after deployed, the stent assumes a substantially circular contour having a diameter d_2 , where d_2 is greater than or equal to d_1 .

Referring now to Figure 1C, the stent **100** is shown in a side view where the non-recessed regions **102**, the recessed regions **104** and the composition **106** contained

-24-

therein run parallel down a length **l** of the stent **100** from a first end **112** to a second end **114**.

Referring now to Figures 1D and E, the stent **100** is shown in its undeployed and its deployed states, respectively, positioned within a vessel **116** having an interior surface or lumen **118**. After deployment of the stent **100** via radial expansion, the stent assumes a substantially circular cross-section having the diameter d_2 , where d_2 is greater than or equal to d_1 . As shown in Figure 1E, the recessed regions **104** are extended and the protected zones **108** and the compositions **106** are elongated relative to their undeployed state bringing the composition **106** into contact with or proximity to the vessel's interior surface **118** or increasing the exposure of the vessel to the composition **106** originally contained within the protected zones **108**.

Referring now to Figures 2A-B, a second embodiment of a stent **200** of the present invention is shown in cross-section to have a generally square cross-section in its un-deployed state and a generally circular cross-section in its deployed state, respectively. The stent **200** includes four substantially rigid arcuate non-recessed regions **202** and four deformable, concave recessed regions **204** interposed between each pair of non-recessed regions **202** so that the regions **202** and **204** alternate. The stent **200** also includes a bioactive composition **206** deposited in protective zones **208** associated with each recessed region **204**. Again, the composition **206** has an outer surface **207** that is below an outer surface **203** of the non-recessed areas **202**.

In its undeployed state, the stent **200**, as shown in Figure 2A, has a first diameter or cross-sectional dimension of d_1 and after deployed, the stent **200** assumes a substantially circular contour having a diameter d_2 in its deployed state, where d_2 is greater than or equal to d_1 .

Referring now to Figure 2C, the stent **200** is shown in side view where the non-recessed region **202**, the recessed regions **204** and the composition **206** contained therein run parallel down a length **l** of the stent **200** from a first end **210** to a second end **212**.

Referring now to Figures 2D-E, the stent **200** is shown in its undeployed and

-25-

its deployed state within a vessel **214** having an interior surface or lumen **216**. After deployment of the stent **200** via primarily radial expansion, a stent's cross-sectional dimension is now d_2 , which is greater than or equal to d_1 , bringing the composition **206** in the elongated and flattened recessed regions **204** into contact with or proximity to the interior surface **216** of the vessel **214** or exposes a greater amount of the interior surface **216** to the composition **206**.

Referring now to Figures 3A-B, a third embodiment of a stent **300** of the present invention is shown in cross-section to have a generally pentagonal (5-sided) cross-section in its un-deployed state and a generally circular cross-section in its deployed state, respectively. The stent **300** includes five substantially rigid arcuate non-recessed regions **302** and five deformable, recessed regions **304** interposed between each pair of non-recessed regions **302** so that the regions **302** and **304** alternate. The stent **300** also includes a bioactive composition **306** deposited in protected zones **308** associated with each recessed region **304**. Again, the composition **306** has an outer surface **307** that is below an outer surface **303** of the non-recessed areas **302**. The stent **300** has an undeployed or first diameter or cross-sectional dimension (largest cross-sectional dimension) d_1 and a deployed or second diameter or cross-sectional dimension (largest cross-sectional dimension) d_2 , where d_2 is greater than or equal to d_1 .

Referring now to Figure 3C, the stent **300** is shown in a side view where the non-recessed region **302**, the recessed regions **304** and the composition **306** contained therein run parallel down a length l of the stent **300** from a first end **310** to a second end **312**.

Referring now to Figures 3D-E, the stent **300** is shown in its undeployed and its deployed state within a vessel **314** having an interior surface or lumen **316**, respectively. After deployment of the stent **300** via primarily radial expansion, the stent's cross-sectional dimension is now d_2 , which is greater than d_1 , bringing the composition **306** in the elongated and flattened recessed regions **304** into contact with or proximity to the interior surface **316** of the vessel **314** or exposes a greater amount

of the interior surface 316 to the composition 306.

Referring now to Figures 4A-B, a fourth embodiment of a stent 400 of the present invention is shown in cross-section to have a generally hexagonal (6-sided) cross-section in its un-deployed state and a generally circular cross-section in its deployed state, respectively. The stent 400 includes six substantially rigid arcuate non-recessed regions 402 and six deformable, recessed regions 404 interposed between each pair of non-recessed regions 402 so that the regions 402 and 404 alternate. The stent 400 also includes a bioactive composition 406 deposited in protective zones 408 associated with each recessed region 404. Again, the composition 406 has an outer surface 407 that is below an outer surface 403 of the non-recessed areas 402.

The stent 400 has an undeployed or first diameter or cross-sectional dimension (largest cross-sectional dimension) d_1 and a deployed or second diameter or cross-sectional dimension (largest cross-sectional dimension) d_2 where d_2 is greater than or equal to d_1 . In this embodiment, the compositions 406 deposited in the zones 408 remain recessed below the non-recessed regions 402, *i.e.*, the outer surface 407 of the compositions 406 are below the outer surface 403 of the non-recessed regions 402 even after deployment.

Referring now to Figure 4C, the stent 400 is shown in a side view where the non-recessed region 402, the recessed regions 404 and the composition 406 contained therein run parallel down a length l of the stent 400 from a first end 410 and a second end 412.

Referring now to Figures 4D-E, the stent 400 is shown in its undeployed and its deployed state within a vessel 414 having an interior surface or lumen 416. After deployment of the stent 400 via primarily radial expansion, the stent's cross-sectional dimension is now d_2 , which is greater than d_1 , bringing the composition 406 in the elongated and flattened recessed regions 404 into contact with or proximity to the interior surface 416 of the vessel 414 or exposes a greater amount of the interior surface 416 to the composition 406.

Referring now to Figures 5A-B, a fifth embodiment of a stent 500 of the present

invention is shown in cross-section to have a generally pleated cross-section in its unde-
ployed state and a generally circular cross-section in its deployed state, respectively.
The stent **500** includes alternating peaks or pleats **502** and deformable recessed regions
504. The stent **500** also includes a bioactive composition **506** deposited in protected
5 zones **504** within the recessed regions **504**. Again, the composition **506** has an outer
surface **507** that is below an outer surface **503** of the non-recessed areas **502**. The stent
500 has an undeployed or first diameter or cross-sectional dimension (largest cross-
sectional dimension) d_1 and a deployed or second diameter or cross-sectional
dimension (largest cross-sectional dimension) d_2 , where $d_2 \geq d_1$.

10 Referring now to Figure 5C, the stent **500** is shown in a side view where the
peaks (non-recessed regions) **502**, the valleys (non-recessed regions) **504** and the
composition **506** contained therein run parallel down a length **l** of the stent **500** from
a first end **508** and a second end **510**.

15 Alternatively, referring now to Figure 5D, the peaks **502**, the valleys **504** and
the composition **506** contained therein of the stent **500** are arranged in a helical
structure down the length **l** of the stent **500** from the first end **508** and the second end
510 where the helix has a twist angle of θ , where θ can range from about 0° (no twist
or parallel orientation) to as high as is commercially practicable, but generally not
exceeding about 120° . It should be recognized that all of the stents described in the
20 preferred embodiments and illustrated by the Figures 1A-4E can have helically
oriented recessed and non-recessed regions and that the number of alternating recessed
and non-recessed regions is limited only by manufacturing criteria depending on the
nature of the stent material.

25 As with the other preferred embodiments described above, after deployment,
the pleated stent **500** via primarily radial expansion, assumes a cross-sectional
dimension d_2 bringing the composition into contact with or proximity to an interior
surface of a vessel (not shown) or exposes a greater amount of the interior surface to
the composition.

Referring now to Figures 6A-E, a sixth embodiment of a stent **600** of the

-28-

present invention is shown in cross-section to have a generally circular cross-sectional contour in its un-deployed state and in its deployed state, respectively. The stent **600** includes a substantially rigid outer surface **602** and an inner surface **604**. Interposed between the outer surface **602** and the inner surface **604** is a bioactive composition **606**. The composition **606** extends from a first surface **608** to a second surface **610** which is below the outer surface **602**. The outer surface **602** has a diameter of d_1 which corresponds to the o.d. of the stent **600** in its undeployed state and the inner surface **604** has a diameter of d_2 which corresponds to the i.d. of the stent **600** in its undeployed state.

Referring now to Figures 6B and C, when applied between the inner surface **604** and the outer surface **602**, the composition **606** appears as a series of alternating bands **612** and raised bands **614** circumscribing the stent **600** along an undeployed length l_1 from a first end **616** to a second end **618**.

Referring now to Figures 6D and E, the stent **600** is shown after deployment where the surfaces **602** and **610** have a diameter d_3 corresponding to the o.d. of the stent **600** in its deployed state and which is greater than or equal to the diameter d_1 . The inner surface **604** has a diameter of d_4 after stent deployment corresponding to the i.d. of the stent **600** in its deployed state and is greater than or equal to the diameter d_2 . In addition to radial expansion, the stent **600** undergoes longitudinal or axial expansion. Thus, after deployment the length l_2 of the stent **600** increase (see Figure 6E). However, the stent **600** can be designed so that l_2 is substantially equal to l_1 . Moreover, after deployment the compositional bands **612** elongate and expand so that their outer surface **620** is brought into contact with or proximity to the interior of a vessel's interior surface or with a tissue.

Referring now to Figure 7A, a seventh embodiment of a stent of the present invention generally **700** is shown in a side view. The stent **700** is of a hollow, substantially cylindrical shape having a length l_1 and a diameter d_1 . In its undeployed state, the stent **700** is designed to close outer regions **702** along seams **704** which seal and protect a bioactive composition **706** with recessed regions **708** of the stent **700**.

-29-

Referring now to Figure 7B, the stent **700** is shown after deployment as a hollow, generally cylinder shape having a length l_2 and a diameter d_2 , where $l_2 \geq l_1$ and $d_2 \geq d_1$. In its undeployed state, the stent **700** is designed to expand radially and longitudinally raising and exposing the recessed regions **708** thereby bringing the bioactive composition **706** into contact with or proximity to a tissue or an interior of a vessel.

Referring now to Figures 8A-B, an eighth embodiment of a stent of the present invention **800** is shown in a cross-section in its undeployed state (Figure 8A) and in its deployed state (Figure 8B). The stent **800** comprises a hollow, substantially cylindrical shape having an undeployed diameter d_1 and a deployed diameter d_2 , where $d_2 \geq d_1$. The stent **800** includes covering regions **802** that close along seams **804** which seal and protect a bioactive composition **806** contained within covered regions **808** of the stent **800**.

In its undeployed state, the stent **800** is under tension, either compressive tension and/or expansive tension, so that the covering regions **802** close at seams **804** to cover and protect the composition **806** contained within the covered regions **808**.

Referring now to Figures 8C-D, the stent **800** is shown before and after deployment as a hollow, generally cylinder shape having an undeployed length l_1 and a deployed length l_2 , where where $l_2 > l_1$. In its undeployed state, the stent **800** is designed to expand radially and longitudinally raising and exposing the covered regions **808** thereby bringing the bioactive composition **806** into contact with or proximity to a tissue or an interior of a vessel.

Although the embodiments depicted in Figures 7A to 8D show the covering regions close completely, alternate constructions include constructions where the stents are compressed so that in the undeployed state less composition is exposed than in the deployed state. That is, when the stent is tension to its undeployed state, the covering regions do not come into contact, but are simply brought closer together than in their deployed state.

Although this embodiments depicted in this section are shown either with final

-30-

circular cross-sections or starting an final circular cross-sections, the stents can be constructed so that the initial and/or final cross-sectional contour is any contour that can be constructed or manufactured or that satisfies the design criteria for deployment in a given site in a body. Thus, the stents can have initial or final cross-sections that are oval, polygonal (trigonal, quadrilateral, pentagonal, *etc.*), pleated, banded, irregular or mixtures or combinations thereof.

If the compositions protected in the protected zones of any of the stents described in the figures above comprises a composition encapsulated by a encapsulating material, then elongation will generally result in a rupture of the encapsulating material. Alternatively, if the composition comprises small beads or capsules surrounded by encapsulating material, then elongation will generally result in the rupture of some or all of the capsules. Alternatively, the encapsulating material may be designed to degrade in a biological setting after some specific time after deployment. Of course, the capsules can be designed to have different degradation rates so that the delivery of bioactive agents is extended over a given period of time. Although this embodiment described in the figures above include a composition contained in the protected zones, it should be recognized that penetrating structures can also be used in addition to or in conjunction with the compositions. In fact, the penetrating structures and compositions can be constructed so that deployment brings the tissue site into contact first with the penetrating structure and/or compositions. These structures would open the tissue site so that the bioactive agents would have improved bio-availability to a targeted site.

Preferred Embodiments of the Stents Including Penetrating Structures

Referring now to Figures 9A-B, an illustrative embodiment of a stent of the present invention **900** is shown in cross-section to have a generally hexagonal cross-sectional profile in its un-deployed state and a generally circular shape in its deployed state, respectively. The stent **900** includes four substantially rigid arcuate non-recessed regions **902** and four deformable, recessed regions **904** interposed between each pair of non-recessed region **902** so that the region **902** and **904** alternate. The stent **900** also

-31-

includes a mechanical penetrating structure **906** deposited in valleys **908** associated with each recessed region **904**. The stent's cross-sectional dimension having a first diameter d_1 and a second diameter or dimension d_2 where $d_2 \geq d_1$.

5 Referring now to Figure 9C, the stent **900** is shown in perspective view where the non-recessed region **902**, the recessed regions **904** and the structure **906** contained therein run parallel down a length l of the stent **900** from a first end **910** and a second end **912**.

10 Referring now to Figures 9D-E, the stent **900** is shown in its undeployed and its deployed state within a vessel **914** having an interior surface or lumen **916**, respectively. After deployment of the stent **900** via radial expansion, the stent's cross-sectional dimension increases to d_2 and as shown in Figure 9F, the recessed regions **904**, the valleys **908** and the structures **906** are elongated and flattened relative to their undeployed state and now contact and penetrate the vessel's interior **920**.

15 Referring now to Figures 10A-B, an illustrative embodiment of a stent of the present invention **1000** is shown in cross-section to have a generally hexagonal cross-sectional profile in its un-deployed state and a generally circular shape in its deployed state, respectively. The stent **1000** includes four substantially rigid arcuate non-recessed regions **1002** and four deformable, recessed regions **1004** interposed between each pair of non-recessed regions **1002** so that the regions **1002** and **1004** alternate.
20 The stent **1000** also includes a combination mechanical or electrochemical penetrating structure **1006** containing a composition **1007** located in protected zones **1008** associated with each recessed region **1004**. The stent's cross-sectional dimension having a first diameter d_1 and a second diameter or dimension d_2 where $d_2 \geq d_1$.

25 Referring now to Figure 10C, the stent **1000** is shown in perspective view where the non-recessed region **1002**, the recessed regions **1004** and the structures **1006** and composition **1007** contained therein run parallel down a length l of the stent **1000** from a first end **1010** to a second end **1012**.

Referring now to Figures 10D-E, the stent **1000** is shown in its undeployed and its deployed state within a vessel **1014** having an interior surface or lumen **1016**. After

-32-

deployment of the stent **1000** via radial expansion, the stent's cross-sectional dimension increases to d_2 and as shown in Figure 10F, the recessed regions **1004**, the protected zones **1008** and the structures **1006** containing the composition **1007** are elongated relative to their undeployed state and now penetrate the tissue or vessel's interior **1020** and delivery the bioactive agents contained within the composition **1007** into the tissue or vessel interior.

All references cited herein are incorporated herein by reference. While this invention has been described fully and completely, it should be understood that, within the scope of the appended claims, the invention may be practiced otherwise than as specifically described. Although the invention has been disclosed with reference to its preferred embodiments, from reading this description those of skill in the art may appreciate changes and modification that may be made which do not depart from the scope and spirit of the invention as described above and claimed hereafter.

-33-

CLAIMS

We claim:

1. A stent comprising:

an elongate body and a protected zone including a composition and/or structure, where the stent has an undeployed state and a deployed state and the zone is substantially protected when the stent is in its undeployed state.

1 2. The stent of claim 1, wherein the body further includes a plurality of protected
2 zones.

1 3. The stent of claim 1, further comprising a plurality of alternating non-recessed
2 and recessed regions, each recessed region comprising a protected zone, where the
3 composition and/or structure is positioned below tops of the non-recessed regions.

1 4. The stent of claim 3, wherein the alternating non-recessed and recessed regions
2 are oriented parallel to an axis running a length of the stent.

1 5. The stent of claim 3, wherein the alternating non-recessed and recessed regions
2 comprise alternating bands oriented radially with respect to an axis running a length
3 of the stent.

1 6. A stent comprising:

2 an elongate body and a protected zone including a composition and/or structure,
3 where the stent has an undeployed state and a deployed state and the protected region
4 is substantially protected when the stent is in its undeployed state and the composition
5 and/or structure is brought into close proximity to or direct contact with a site in a body
6 of an animal, when the stent is in its deployed state.

-34-

1 7. The stent of claim 6, wherein the body further includes a plurality of protected
2 regions.

1 8. The stent of claim 6, further comprising a plurality of alternating non-recessed
2 and recessed regions, each recessed region forming a protected region, where the
3 composition and/or structure is positioned below tops of the non-recessed regions.

1 9. The stent of claim 8, wherein the alternating non-recessed and recessed regions
2 are oriented parallel to an axis running a length of the stent.

1 10. The stent of claim 8, wherein the alternating non-recessed and recessed regions
2 comprise alternating bands oriented radially with respect to an axis running a length
3 of the stent.

1 11. A stent comprising:
2 a body and a protected zone including a composition and/or structure and
3 formed by two non-recessed regions and a recessed region, where the stent has an
4 undeployed state and a deployed state and the protected zone is substantially protected
5 when the stent is in its undeployed state and the composition and/or structure is
6 brought into close proximity to or direct contact with a site in a body of an animal,
7 when the stent is in its deployed state..

1 12. The stent of claim 11, wherein the body is elongate.

1 13. The stent of claim 11, further comprising a plurality of alternating non-recessed
2 and recessed regions, each recessed region forming a protected zone and there the
3 composition and/or structure includes a bioactive or biopenetrating agent.

1 14. The stent of claim 13, wherein the alternating non-recessed and recessed regions

2 are oriented parallel to an axis running a length of the stent.

1 15. The stent of claim 13, wherein the alternating non-recessed and recessed regions
2 comprise alternating bands oriented radially with respect to an axis running a length
3 of the stent.

1 16. A stent comprising:
2 a first end;
3 a second end;
4 a first cross-sectional dimension when the stent is in an undeployed state;
5 a second cross-sectional dimension when the stent is in a deployed state;
6 a protected zone formed between two non-recessed region and a recessed
7 region, where zone includes a composition and/or structure positioned below tops of
8 the non-recessed regions,
9 where the tops of the non-recessed region protect the composition and/or
0 structure during stent positioning and deployment and during deployment the
1 composition and/or structure is brought into close proximity to or direct contact with
2 a site in an animal body.

1 17. The stent of claim 16, wherein the stent is elongate.

1 18. The stent of claim 16, further comprising a plurality of alternating non-recessed
2 and recessed regions, each recessed region forming a protected zone including
3 composition and/or structure positioned below tops of the non-recessed regions.

1 19. The stent of claim 16, wherein the alternating non-recessed and recessed regions
2 are oriented parallel to an axis running a length of the stent.

1 20. The stent of claim 16, wherein the alternating non-recessed and recessed regions

-36-

2 comprise alternating bands oriented radially with respect to an axis running a length
3 of the stent.

1 21. A method for deploying a stent comprising the steps of:
2 positioning a stent of claims 1, 6, 11 or 16 at a site in an animals body while the
3 stent is in its undeployed state, where the protected zone including the composition
4 and/or structure is substantially protected; and
5 deploying the stent in the site so that the stent assumes its deployed state
6 bringing the composition and/or structure into close proximity to or direct contact with
7 to the site.

1 22. A method for administering a therapeutic affect to a site of an animals body
2 comprising the steps of:
3 positioning a stent of claims 1, 6, 11 or 16 at a site in an animals body while the
4 stent is in its undeployed states, where the protected zone including the composition
5 and/or structure is substantially protected; and
6 deploying the stent in the site so that the stent assumes its undeployed states and
7 bringing the composition ans/or structure into close proximity to or direct contact with
8 the site; and
9 delivering a therapeutic affect via the composition and/or structure to the site.

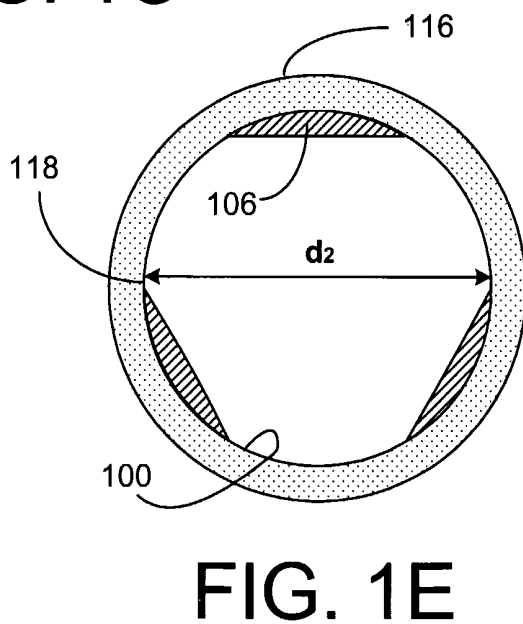
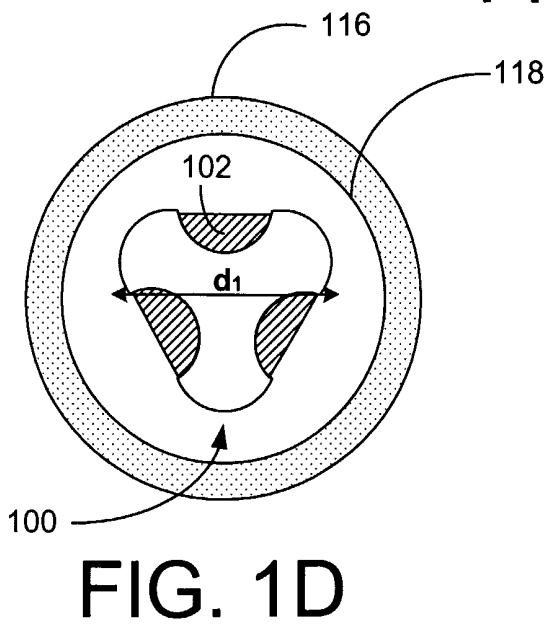
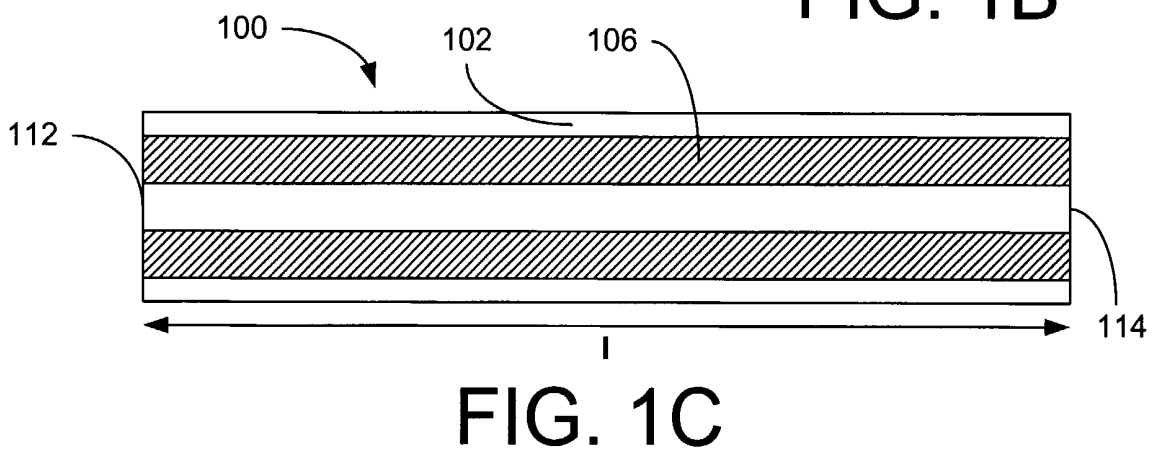
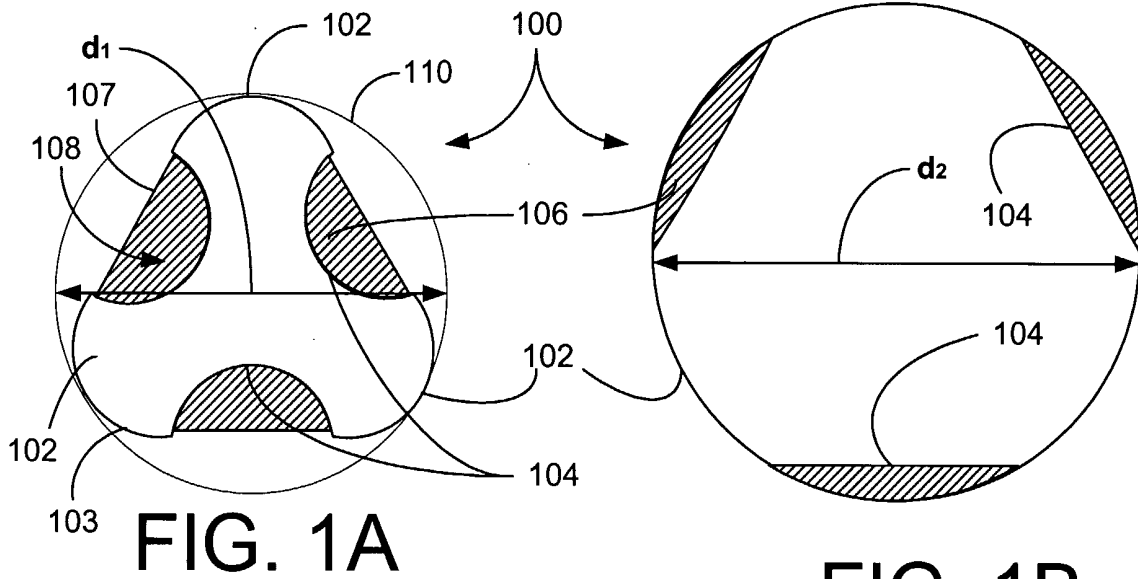

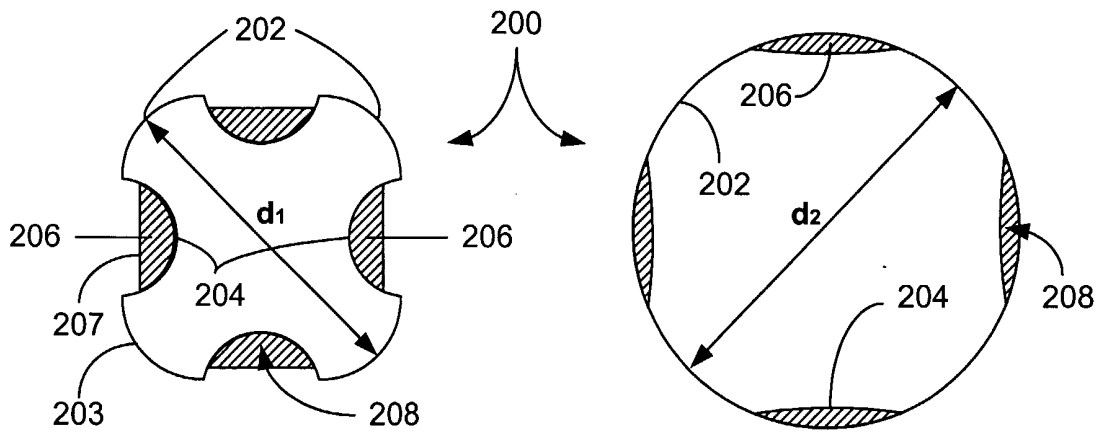

FIG. 2A

FIG. 2B

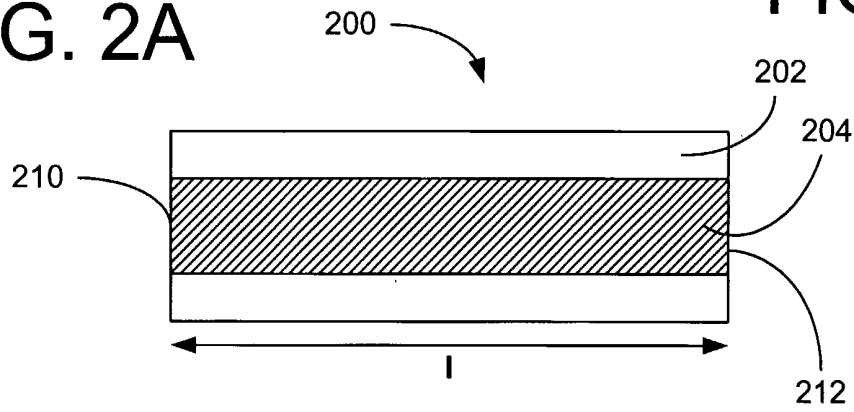

FIG. 2C

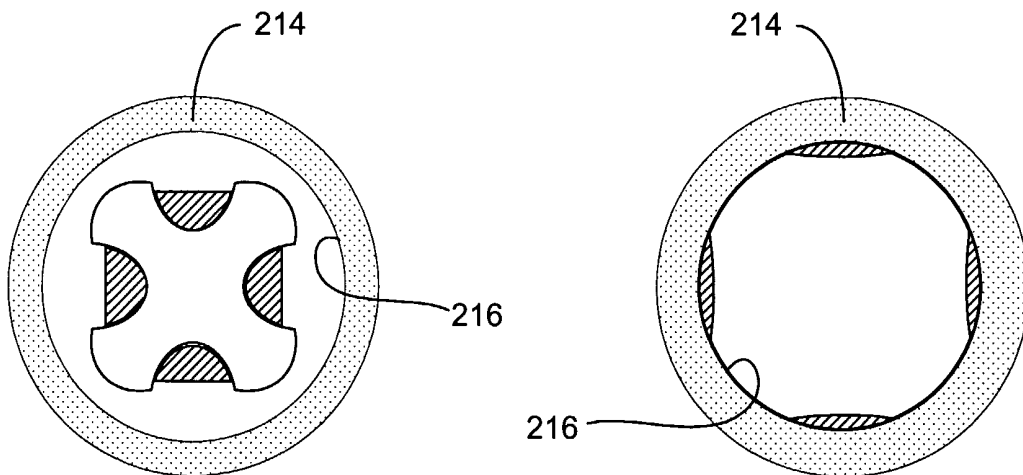

FIG. 2D

FIG. 2E

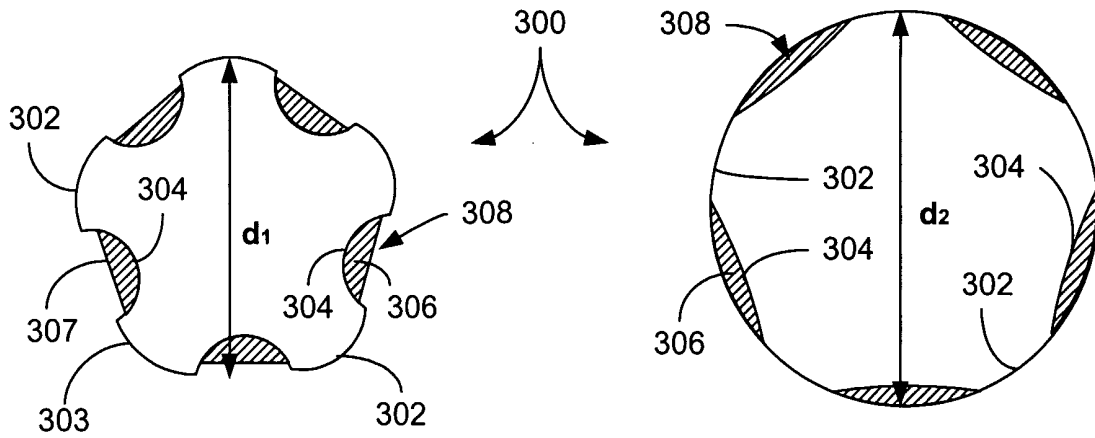

FIG. 3A

FIG. 3B

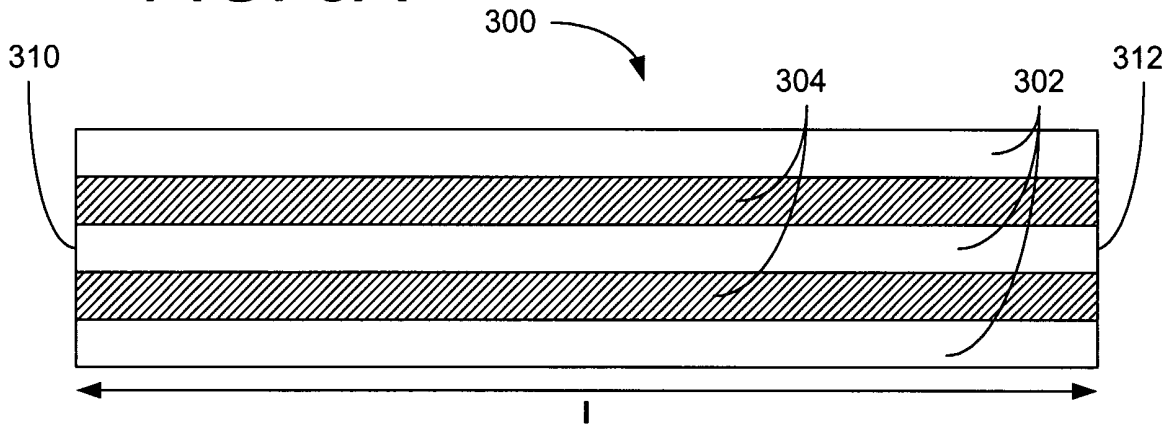

FIG. 3C

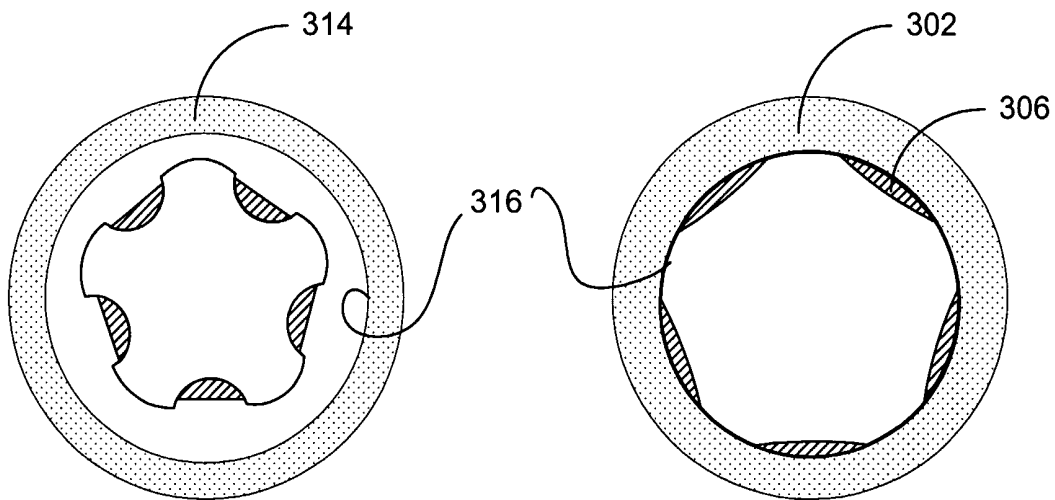

FIG. 3D

FIG. 3E

4/11

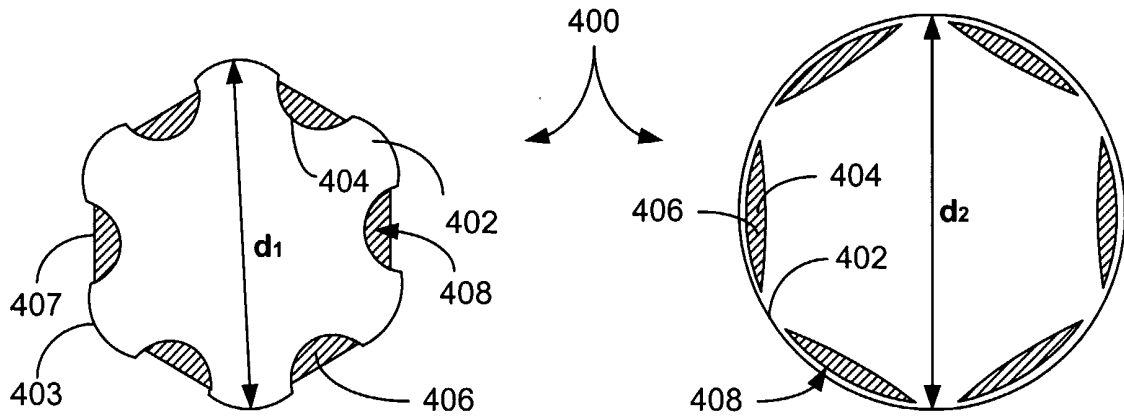

FIG. 4A

FIG. 4B

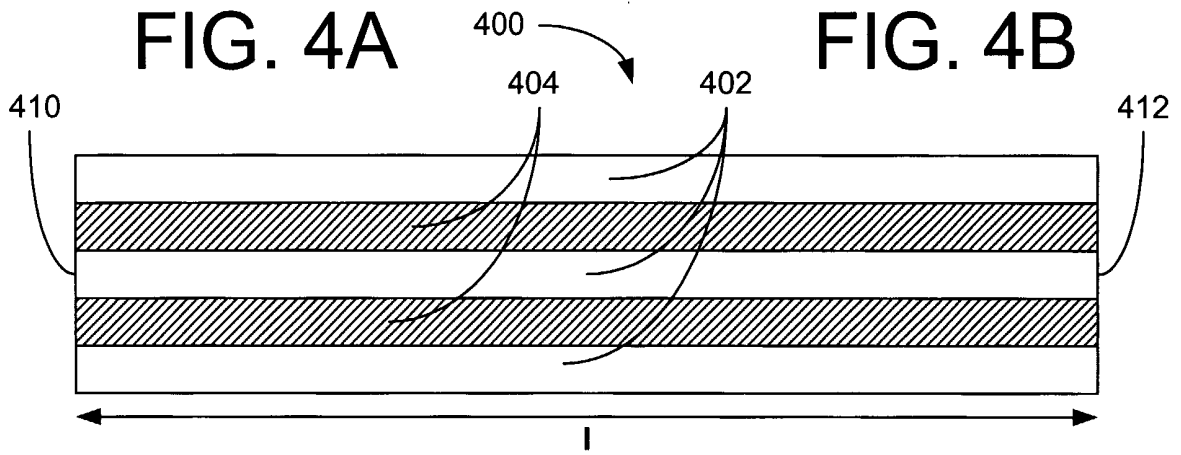

FIG. 4C

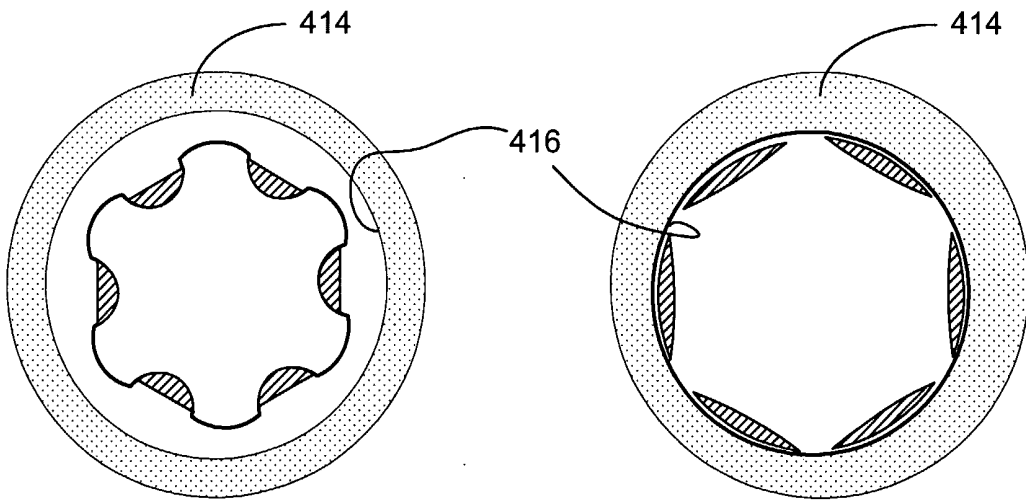
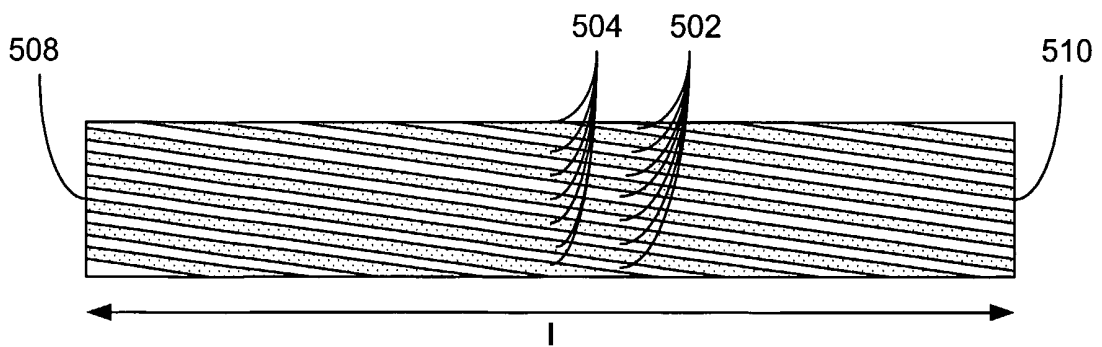
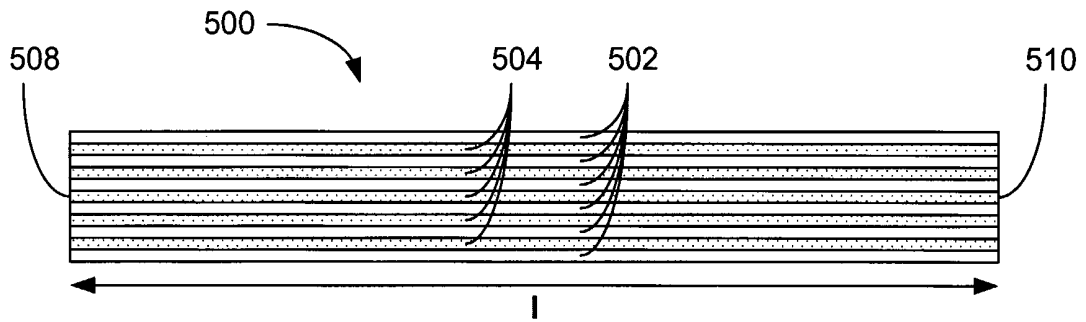
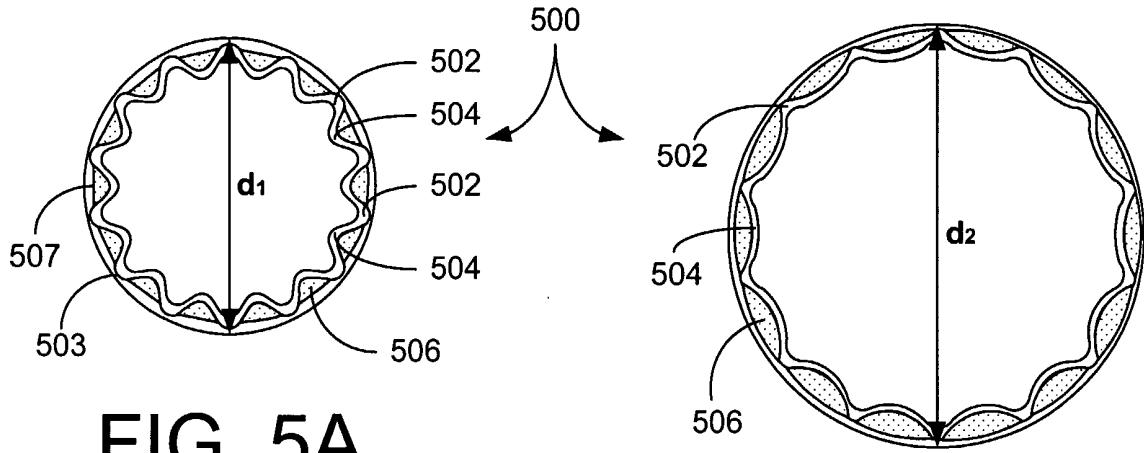

FIG. 4D

FIG. 4E

5/11



6/11

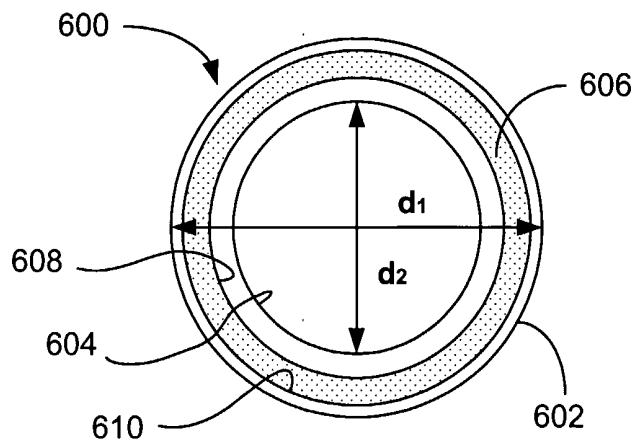

FIG. 6A

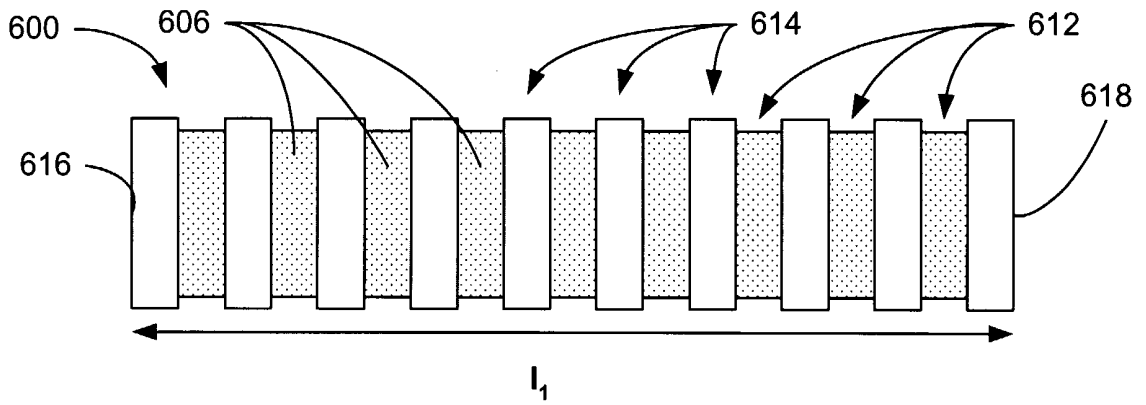

FIG. 6B

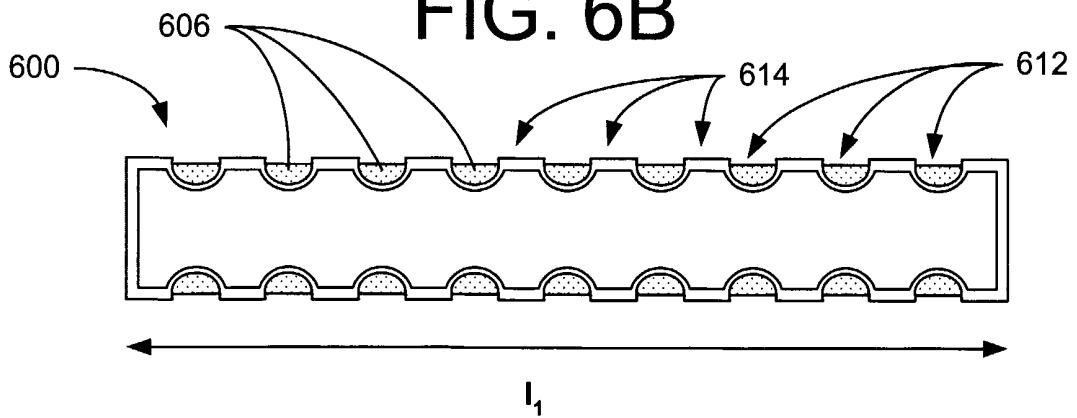

FIG. 6C

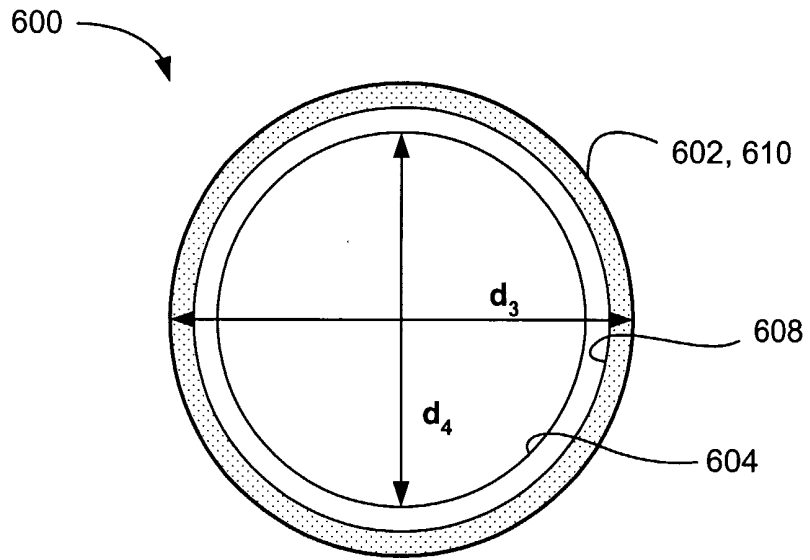

FIG. 6D

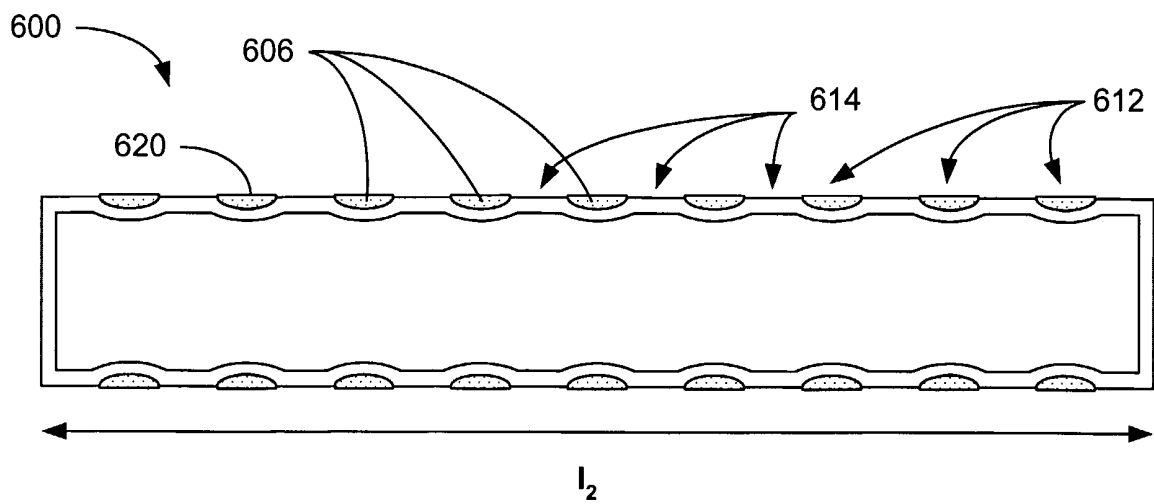

FIG. 6E

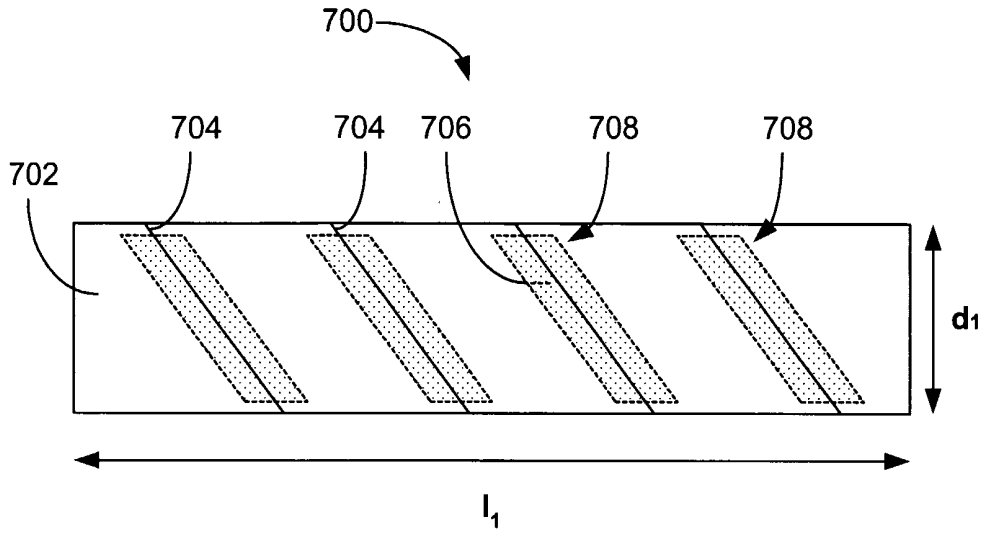

FIG. 7A

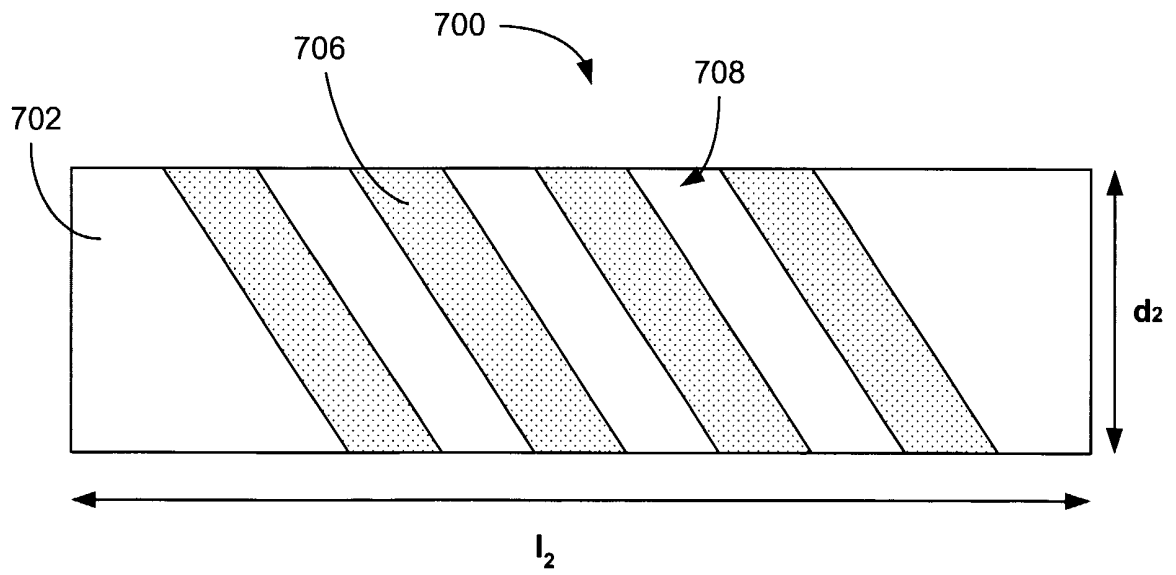

FIG. 7B

9/11

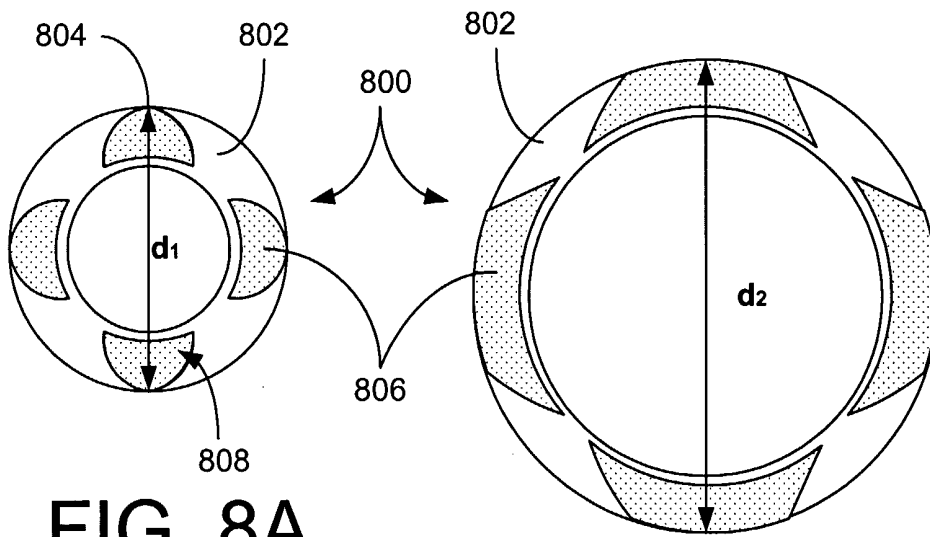

FIG. 8A

FIG. 8B

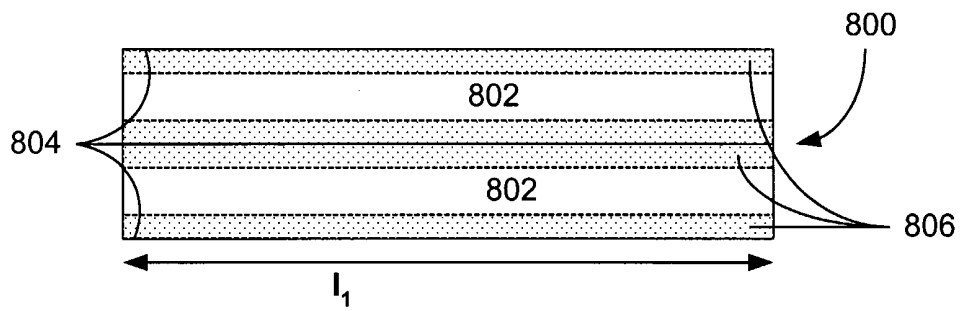

FIG. 8C

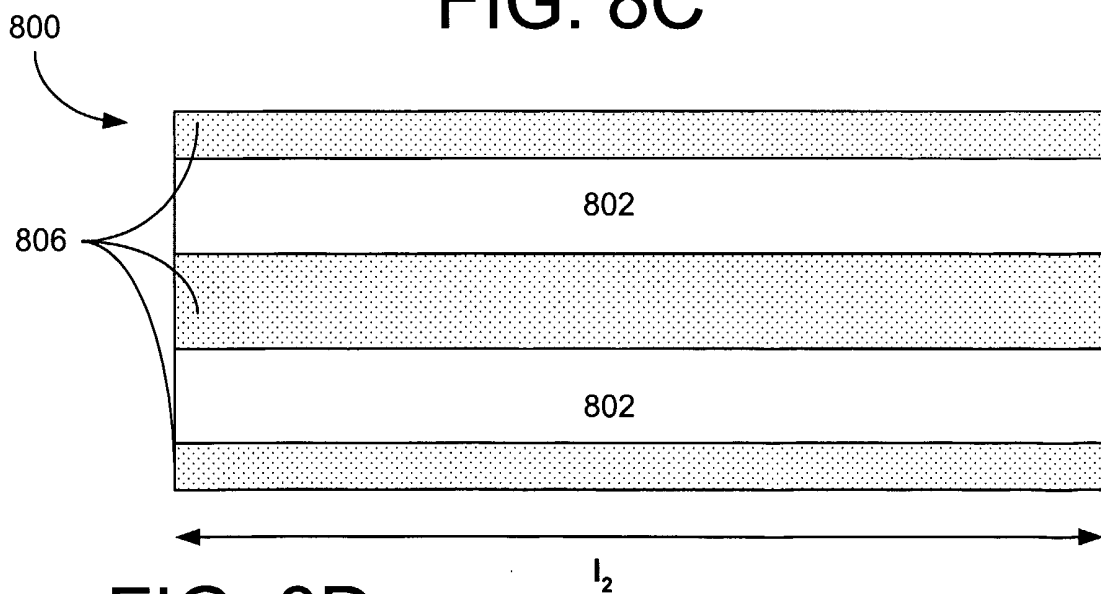

FIG. 8D

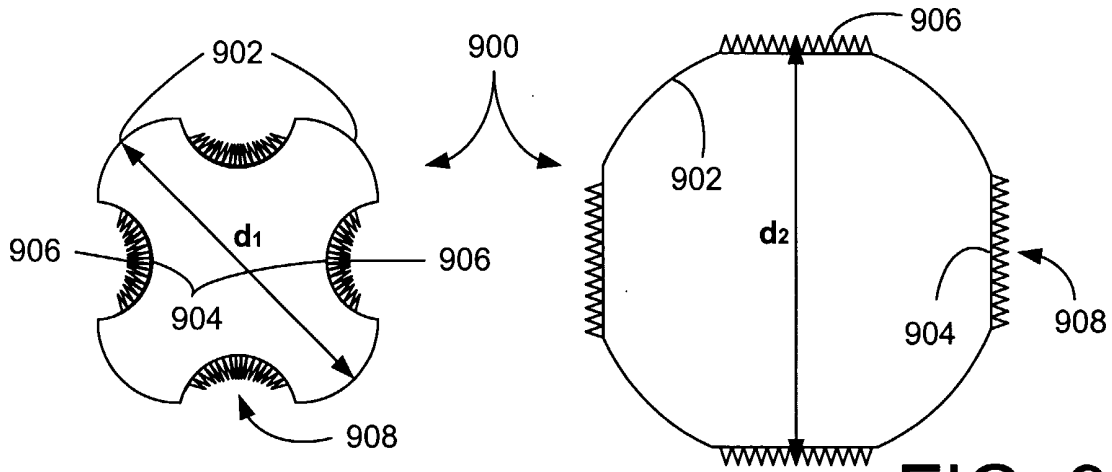

FIG. 9A

FIG. 9B

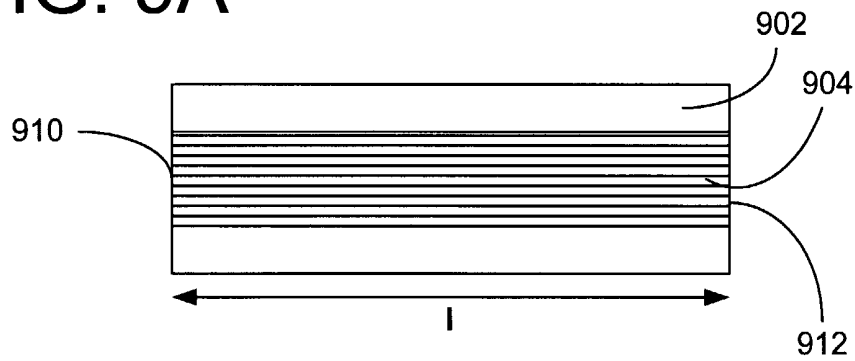

FIG. 9C

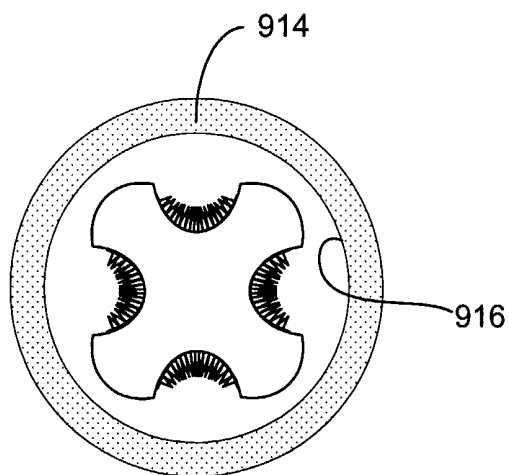

FIG. 9D

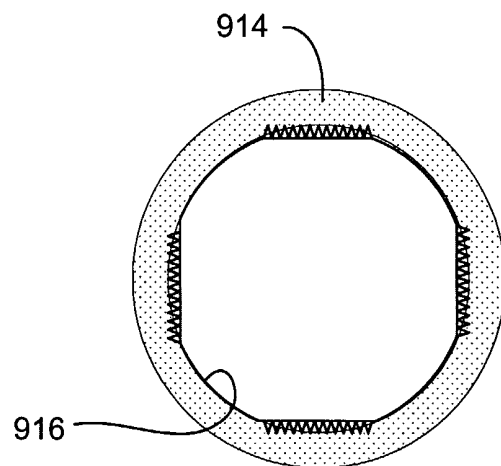

FIG. 9E

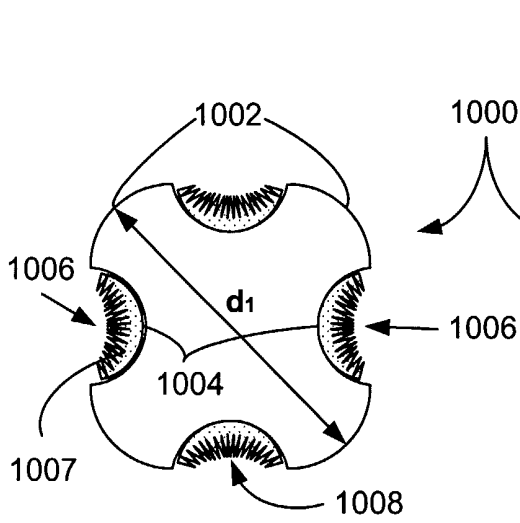

FIG. 10A

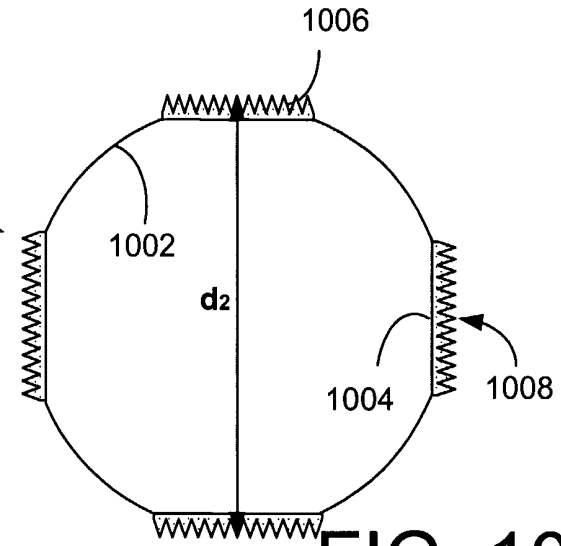

FIG. 10B

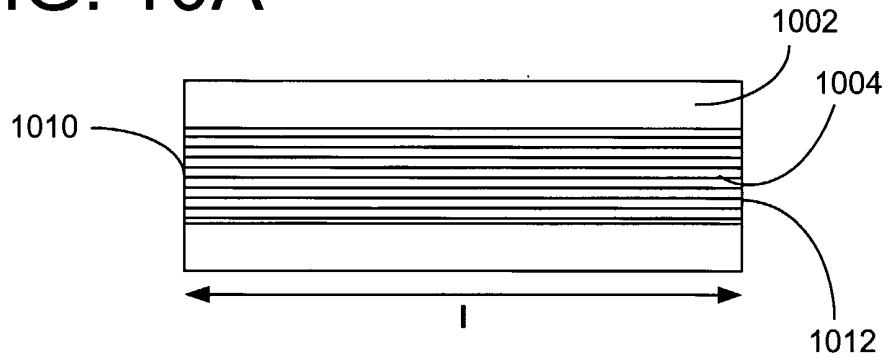

FIG. 10C

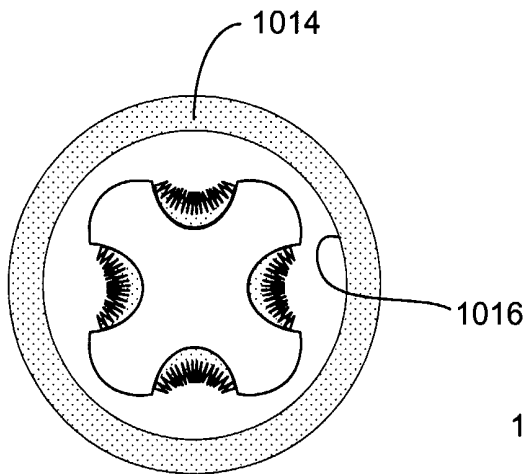

FIG. 10D

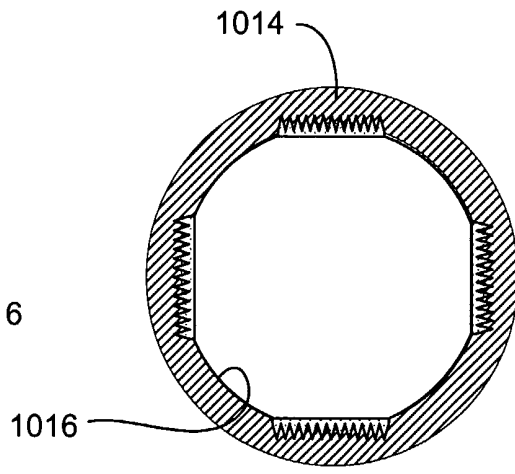

FIG. 10E