

June 14, 1966

J. A. GEHRM

3,255,702

HOT LIQUID METAL PUMPS

Filed Feb. 27, 1964

5 Sheets-Sheet 1

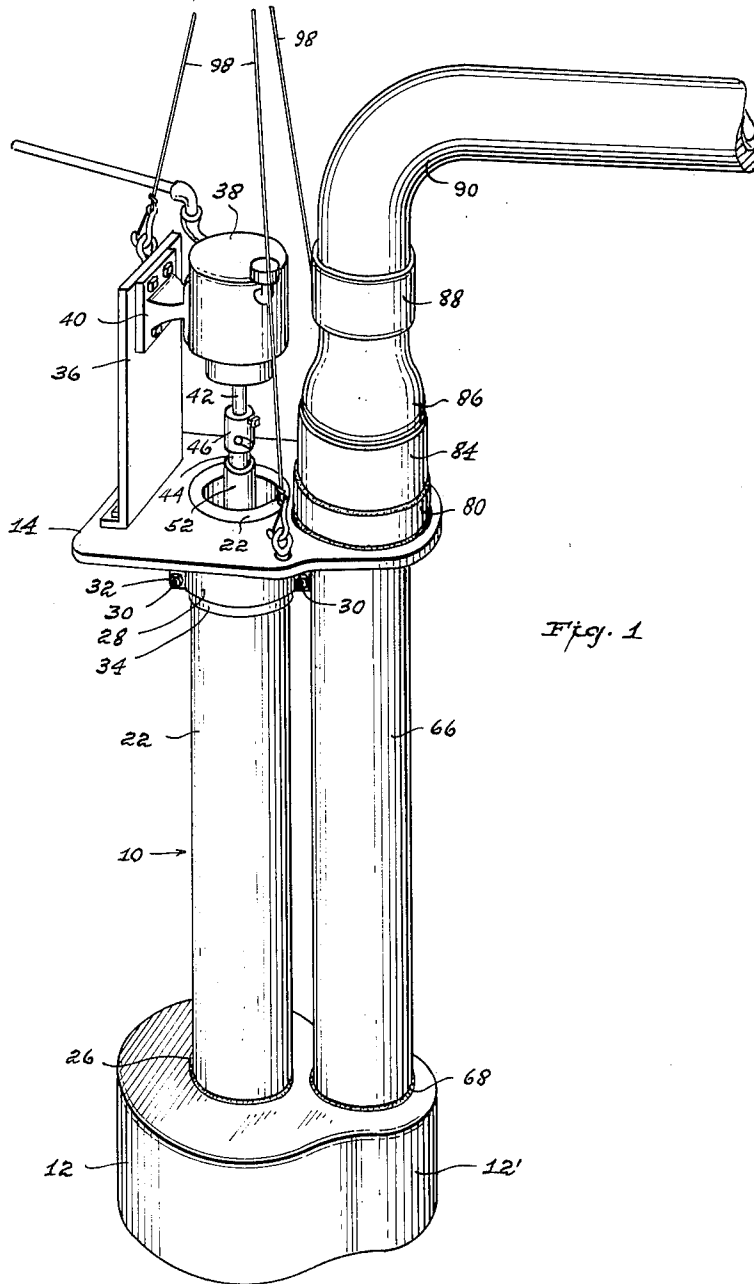

Fig. 1

John A. Gehrm  
INVENTOR.

BY *J. M. Mills*  
ATTORNEY

June 14, 1966

J. A. GEHRM

3,255,702

HOT LIQUID METAL PUMPS

Filed Feb. 27, 1964

5 Sheets-Sheet 2

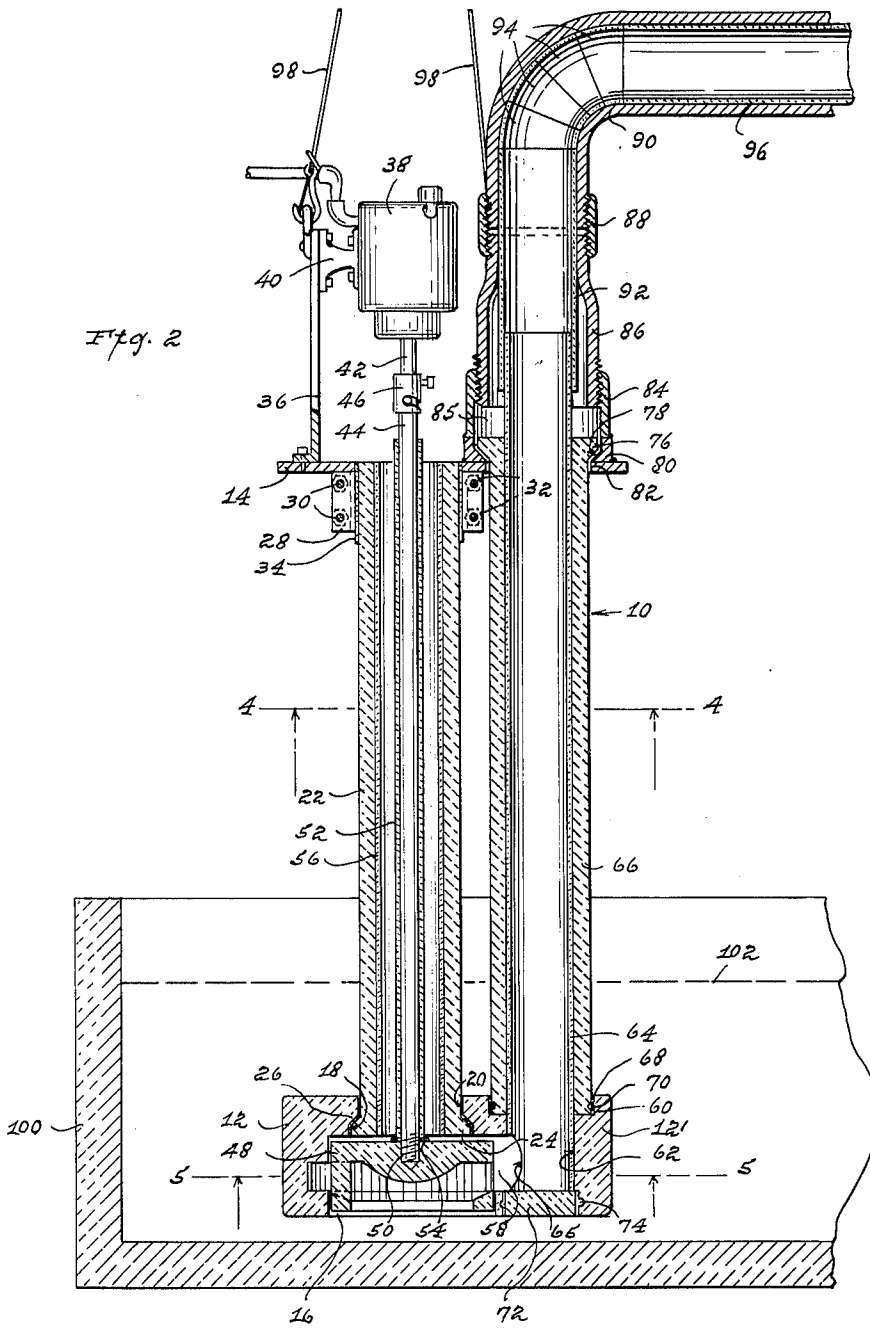

John A. Gehrm  
INVENTOR.

BY *J. M. Wells*  
ATTORNEY

June 14, 1966

J. A. GEHRM

3,255,702

HOT LIQUID METAL PUMPS

Filed Feb. 27, 1964

5 Sheets-Sheet 3

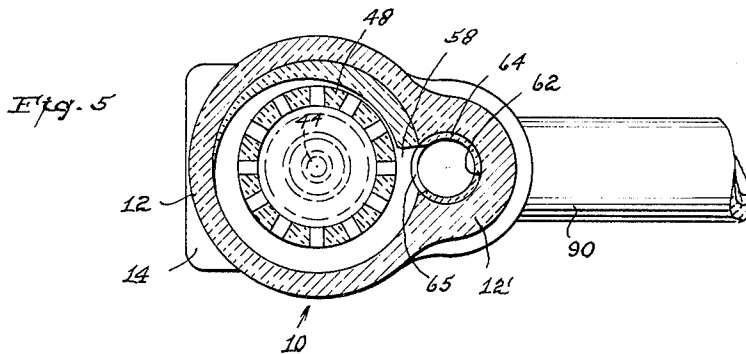
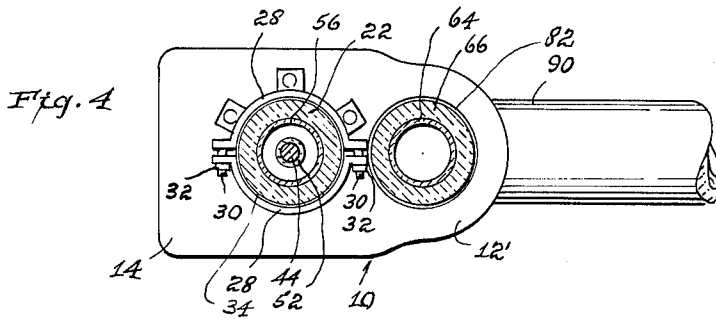
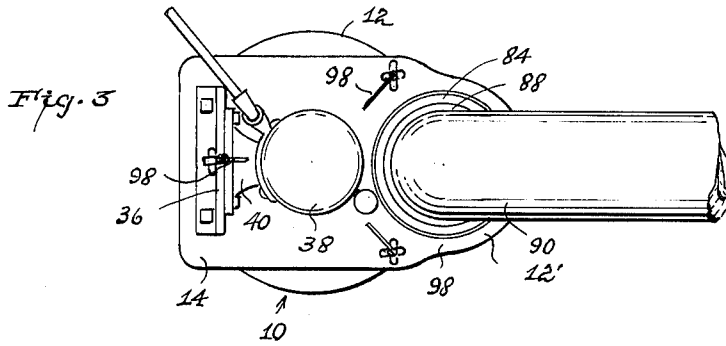

John A. Gehrm  
INVENTOR.

BY *J. M. Mills*  
ATTORNEY

June 14, 1966

J. A. GEHRM

3,255,702

HOT LIQUID METAL PUMPS

Filed Feb. 27, 1964

5 Sheets-Sheet 4

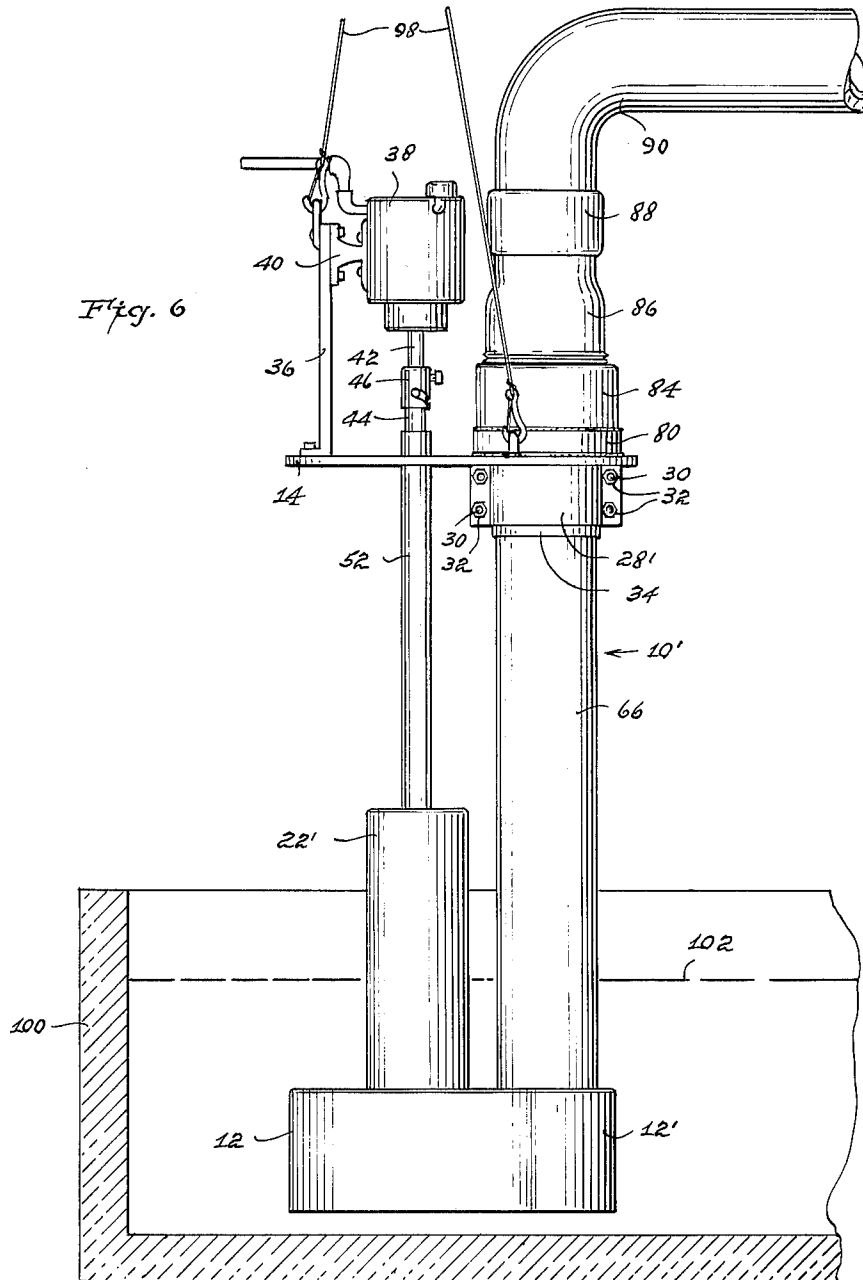

John A. Gehrm  
INVENTOR.

BY *J. M. Mills*  
ATTORNEY

June 14, 1966

J. A. GEHRM

3,255,702

HOT LIQUID METAL PUMPS

Filed Feb. 27, 1964

5 Sheets-Sheet 5

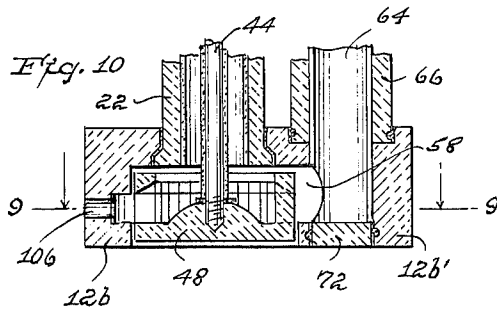
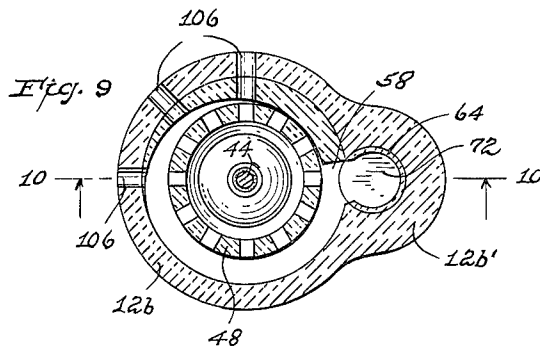
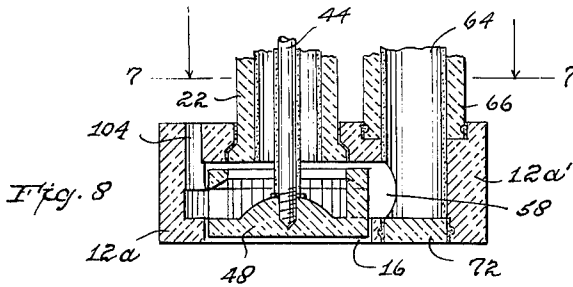
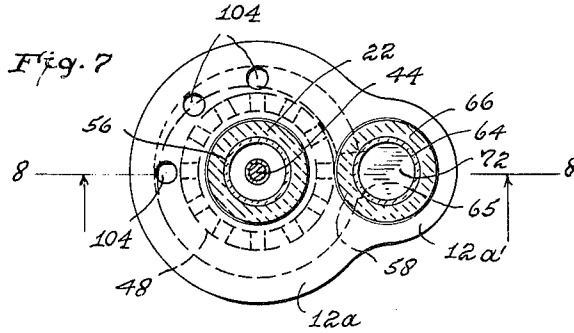

John A. Gehrm  
INVENTOR.

BY *J. W. Mills*  
ATTORNEY

1

3,255,702

**HOT LIQUID METAL PUMPS**

**John A. Gehrm, Gettysburg, Pa., assignor to Molten Metal Systems, Inc., a corporation of New Jersey**  
 Filed Feb. 27, 1964, Ser. No. 347,925  
 3 Claims. (Cl. 103-114)

This invention relates to improvements in pumps intended for use in lifting, moving, transferring and circulating molten and fluid metals, chemicals, salts and other materials, whether hot or cold, which are difficult, hazardous and corrosive.

Pumps designed for the pumping of molten metal or other molten materials are of necessity constructed of ceramic or other refractory materials which are of brittle character and subject to rupture under severe stresses, such, for example, as those caused by unequal thermal expansion and contraction of rigidly connected ceramic parts, as in a pump having two or more elongated ceramic tubes rigidly connecting an elevated mounting plate for an impeller motor with the impeller housing which is immersed in and conveying hot metal from a melting furnace or other receptacle through one of the connecting tubes or pipes. The stresses on the other parts of the pump resulting from the greater thermal expansion of the pipe conducting the molten material will ultimately cause a rupture in some part or joint of the pump structure and thus totally destroy its usefulness.

Therefore, one of the principal objects of the present invention is to provide a molten metal pump of refractory material in which injurious stresses on the component parts and the consequent self-destruction of the pump are positively precluded. An important feature of construction by which this advantageous result is accomplished resides in rigidly connecting the mounting plate for the motor to the impeller housing by means of only a single pipe or supporting member and leaving the other pipe or members of the pump unit free for independent longitudinal thermal expansion without affecting other parts of the pump structure. The mounting plate is provided with means for freely suspending it, together with the impeller shaft and housing from an overhead support, so that the bottom of the housing can be spaced in any desired plane above the floor of the furnace or other receptacle from which the molten material is pumped.

Another, and important object of this invention is to provide the pipes of the pump which conduct, or are immersed in, the liquid being pumped with relatively thin, insertable and removable tubular liners made of semi-soft, compressible and non-wetting material which is highly resistant to normal wear, stress and adhesiveness under conditions of heat and corrosive tendencies from the liquid to which they are exposed, irrespective of whether the liquid is hot or cold. These liners not only compensate for the thermal expansion of the pipe, or pipes, but they also resist the corrosive action and high heat conditions and also minimize the abrasive wear and chemical reactions exerted by molten metal in the pipes, and also, due to their elasticity and compressibility the liners absorb shock, protect the pipes and permit easy and inexpensive repairs by simple replacement of the liners instead of the pipes. The pipe or riser through which molten material is pumped is preferably provided with a pair of liner sections of the material referred to in

2

telescopic but leak-proof relation to permit their independent thermal expansion and also to permit the lower section of the liner to be withdrawn from the riser pipe with metal or other molten material which may have been allowed to freeze or solidify therein, after which a new section can be inserted in the riser. Notwithstanding the protection afforded by the tubular liners referred to the riser pipe as well as any other pipe connected with the impeller housing is preferably made of high heat resistant material.

In my improved pump all joints between connected parts are sealed with a material of sufficient resiliency to withstand the maximum thermal expansion and still maintain the strength necessary to prevent the rupture or failure of the joints under stresses to which they are subjected.

In my improved pump the impeller shaft extending from the elevated motor to the impeller in the impeller housing may be incased with the same material as that of the liners referred to, especially if the shaft is made of metal; or the shaft may be made of a material or a combination of materials which resists the corrosive action of the fluid material and the conditions of heat prevailing. The shaft may be housed in a vertical pipe to which the mounting plate is rigidly attached, or partially housed in a pipe stopping short of the mounting plate, in which case the mounting plate may be attached to the riser through which the liquid material is pumped, or to a separate single supporting column rigidly connected at its lower end to the impeller housing.

All parts of my improved pump that are immersed in or contain liquid metal are made of a material which will resist corrosive action of the metal being pumped and have sufficient strength at the temperatures involved to perform the pumping action and convey the materials being pumped. Each of the parts, or in combination, is of a material or design that will allow each to move within or in relation to others independently or individually according to the thermal expansion. The mounting plate or frame is kept out of the molten material at a distance safely beyond the reach and out of the heat to prevent its deterioration. The impeller housing is so designed as to have uniform dimensional stability achieved by choice of materials and/or combination of materials sized to present units of equal thickness, so as to prevent unequal stress and expansion due to heat, wear and weight. The materials of construction are of improved characteristics and design so that it has ample strength to allow for torque and resiliency to the shocks of starting and speed of rotation in the spinning of the impeller at a rate to centrifugally force the molten metal or other material up through and out of the riser or discharge pipe. Openings for the admission of liquid to be pumped into the impeller housing may be provided in the bottom, or the top of the housing with the impeller installed in reverse relation; or the openings may be in the side of the housing, irrespective of the arrangement of the impeller.

Further objects and advantages of my improved pump will appear or be pointed out in the following specification in which reference is directed to the accompanying drawings forming a part thereof, and in which:

FIG. 1 is a perspective view of one form of molten metal pump in accordance with my invention;

FIG. 2 is an elevational sectional view of the pump shown in FIG. 1;

FIG. 3 is a top plan view of the pump shown in FIGS. 1 and 2;

FIG. 4 is a sectional view taken on the line 4—4 of FIG. 2;

FIG. 5 is a sectional view taken on the line 5—5 of FIG. 2;

FIG. 6 is a side elevation showing a modification of the pump shown in the previous views;

FIG. 7 is a top plan sectional view taken on the line 7—7 of FIG. 8, showing the impeller housing provided with openings for admission of liquid through its top wall instead of its bottom wall;

FIG. 8 is a section taken on the line 8—8 of FIG. 7, showing the impeller installed in inverted relation to its arrangement as shown in FIG. 2;

FIG. 9 is a top plan section taken on the line 9—9 of FIG. 10 showing the impeller housing provided with openings for admission of liquid through its side wall instead of its top or bottom wall; and

FIG. 10 is a section taken on the line 10—10 of FIG. 9.

Referring to the drawings in which like numerals designate like parts in the several views, and referring first to FIGS. 1 to 5, my improved pump is designated generally by the numeral 10, and the specific form illustrated in the views referred to includes an impeller housing 12 having parallel top and bottom walls and a vertically spaced mounting plate 14. This housing has a large circular opening 16 in its bottom wall and has a through opening in its top wall defining an inwardly facing frusto-conical recess or seat 18 merging upwardly at its reduced end into a short straight bore 20. Through the opening 16 and the bore 20 is inserted an elongated pipe 22 having on its lower end an upwardly tapered flange 24 of a shape and size to fit within the seat 18, but with a narrow surrounding space to receive a filling of a material 26 of a character which attaches and seals the pipe 22 to the housing 12, and has sufficient resiliency to permit a substantial degree of thermal expansion of the attached parts without danger of rupture of the joint or seal.

The pipe 22 is attached at its upper end to the mounting plate 14 through a two-part clamp 28 carried by the mounting plate and held in clamping relation by bolts or studs 30 and nuts 32, shown more clearly in FIG. 4, with an insulating liner 34 between the clamp and pipe. However, it should be understood that various other suitable means for attaching the pipe or other support to the mounting plate may be substituted.

A vertical support 36 is mounted on the mounting plate and a motor 38 (which may be of electrical, air or hydraulic type) is attached to the vertical support through a lateral bracket 40, or other suitable means, with the shaft 42 of the motor in concentric relation with the pipe 22. An impeller shaft 44 is detachably connected to the motor shaft through a suitable coupling 46 and extends through the pipe 22 into the impeller housing 12 where it is rigidly attached to a horizontal rotary impeller 48 by suitable means, the impeller and shaft being insertable and removable through the opening 16, which is of a greater diameter than that of the impeller. In the specific form of my invention illustrated in FIGS. 1 to 5 the shaft 44 is inclosed throughout the greater portion of its length within a thin casing 52 made of non-wetting, resilient, high heat and corrosion resistant material with a gasket 54 of similar material interposed between the lower end of the tube 46 and the top of the impeller housing 12. A tube or liner 56 of similar material is removably inserted in the pipe 22 throughout its length as a replaceable means of protection of the inner wall of the pipe. However, the shaft 44 and the pipe 22 may be made of a material having the characteristics mentioned so that the tube 46 and the tubular liner 50 may be omitted. The impeller housing 12 and the impeller 48 are made of ceramic or other suitable refractory material.

The impeller housing merges at one side into a reduced

portion 12' containing a liquid outlet chamber 58 in open lateral communication with the interior of the impeller housing containing the impeller 48. A vertical recess 60 is formed in the top wall of the portion 12' and a central reduced bore 62 extends from the recess 60 entirely through the portion 12' to receive a liner section 64 inserted within a second pipe or riser 66 of a slightly lesser diameter than that of the recess 60 and the lower end of which is seated in the recess and anchored therein by means of heat resistant resilient sealing material 68 in the space between the wall of the recess and the riser 66, which may be provided with an annular groove 70 to receive the sealing material to form a sealed joint. The lower end of the bore 62 is slightly enlarged to receive a refractory plug 72 against which the lower end of the tubular liner 64 rests to hold it within the riser 66. This plug is firmly anchored in the recess of the bore by means of sealing material 74, but may be forcibly withdrawn for replacement of the tubular liner, or removal of any frozen material or other obstruction. The tubular liner 64 has a large lateral opening 65 at its bottom end in communication with the impeller chamber.

The upper end of the riser 66 terminates in a downwardly tapered flange 76 similar to the flange 24 of the pipe 22 and this flange 76 is inclosed by, but slightly spaced from, a frusto-conical recess 78 formed in a collar 80 welded to or otherwise rigidly attached to the mounting plate 14, so that the riser 66 is left free for thermal expansion through an opening 82 in the mounting plate in concentric relation with the recess 78 without exerting any stress on either the mounting plate, riser, impeller housing or other parts of the pump structure. With this arrangement the impeller housing 12, the riser pipe 66 and all parts carried by them are attached to the mounting plate by a single support, which in the form illustrated is the pipe 22. However, as will later be explained the riser 66 or some other element may be utilized as the single supporting member, if desired.

Welded or otherwise rigidly attached to the upper end of the collar 80 is a cylindrical extension fitting 84 internally threaded at its upper end and connected to the externally threaded end of a reducing sleeve 86. This extension fitting 84 has a short bore 85 below its internal threads of a slightly larger diameter than that of flange 76, which not only allows lateral expansion of the flange but also allows pipe 66 to expand longitudinally without stress on any part of the pump unit. The internally threaded end of the extension fitting 84 is connected to the larger externally threaded end of a reducing sleeve 86. The externally threaded reduced end of the sleeve 86 is connected to a double internally threaded coupling 88, the outer end of which is connected to the end of a pipe extension 90. The reduced internal diameter of the sleeve 86 is slightly greater than that of the tubular liner section 64, the end of which terminates within the larger diameter of the sleeve. Within the reduced portion of the sleeve 86 is a short tubular liner section 92 of the same material, and fitting over the upper end of the liner section 64 in telescopic but leak-proof relation therewith, to permit independent thermal expansion of the liner sections. Abutting the liner section 92 is a series of segmental sections 94 in the curved portion of the elbow pipe section 90, the outer one of which is abutted by a horizontal liner section 96. However, a single liner section corresponding to all the separate sections 92, 94 and 96 can be manufactured as a single unit.

The mounting plate 14 is provided with supporting cables 98 or other suitable means, through which it is suspended from an overhead support (not shown), with the impeller housing in any desired plane above the floor of the furnace or other container 100 of the molten metal or other liquid material to be pumped.

In operation the impeller 48, driven by the motor 38, centrifugally forces the liquid 102 in the container 100

through opening 65 and through the riser 66 and extensions to the desired point of delivery. Since the mounting plate 14 and impeller housing 12 are connected together in spaced relation only by the pipe 22 the riser pipe 66 can freely move longitudinally through the opening 82 in the mounting plate and the bore 85 in the extension 84, as well as expand laterally therein; and the liners through which hot metal or material is pumped are free for telescopic independent movement. None of the parts of the pump are subject to stress due to thermal expansion of any of the other parts. Therefore, all possibility of self-destruction of the pump is positively precluded.

As previously mentioned, if molten metal or other material is allowed to solidify in the tubular liner section 64 it can be withdrawn from the riser upon withdrawal of the plug 72 and replaced with a new liner. Also the tubular liner in pipe 22 can be withdrawn and replaced by detaching the pipe from the clamp 28.

From the foregoing description it will be seen that the entire pump assembly is supported solely by the pipe 22 with the mounting plate and motor at a sufficient distance above the hot metal supply to prevent any damage from the heat. In addition to the function of the tubular liners 56 and 64 in protecting the pipes 22 and 66 against corrosive action of the hot liquid being pumped the liners serve as insulators against the transfer of excessive heat to the pipes. Also the casing 52 protects the shaft 44 against excessive heat damage and corrosive action from hot metal or material. Thermal longitudinal expansion and contraction of pipe 22 affects only the spacing of the mounting plate and impeller housing without stress on either or other parts of the pump. Thermal expansion and contraction of riser 66 affects no part of the pump structure, since it can move freely through the opening 82 in the mounting plate and the bore 85 in the extension 84.

In FIG. 6 is shown a modified form of my improved pump in which the riser pipe 66, through which the hot metal or the like is conducted, is utilized as the single support for supporting the impeller housing 12 on the mounting plate 14 in parallel spaced relation. In this embodiment of my invention the clamp 28, or other suitable clamping means, carried by the mounting plate is applied to the riser pipe 66, instead of the pipe 22, or other support, so that the mounting plate is attached to the pipe 66. The pipe 22' may then be shortened, as illustrated, so that it has no contact with the mounting plate. The construction of the short pipe 22' may be identical with the lower portion of the pipe 22, and its means of attachment to the impeller housing 12 may also be the same, as shown in FIG. 2. This shorter pipe serves the same purpose as the pipe 22 in eliminating the necessity for a packing between the housing and the shaft 52, the pipe 22' being of sufficient height to preclude the splashing from its top of molten metal agitated by the impeller 48. This still maintains the concept and principle of connecting the impeller housing to the mounting plate in distantly spaced relation by means of a single support, thus permitting movement of the housing toward and from the mounting plate without exerting the least stress on any other parts of the pump unit.

From the foregoing description it will be seen that the impeller housing may be connected to the mounting plate in spaced relation by single support entirely separate from either of the pipes 22 and 66.

In the form of my invention shown in FIGS. 7 and 8 the impeller housing 12a is provided with openings 104 in its top wall for admission of liquid into the housing, and the impeller 48 is installed in the housing in inverted relation to its arrangement shown in the previous views. Otherwise the construction of the entire unit may be the same as shown in FIGS. 1 to 5 or in FIG. 6.

In the form of my invention shown in FIGS. 9 and 10 the impeller housing 12b is provided with openings 106

in its side wall for admission of liquid into the housing. In this embodiment the impeller 48 may be installed either in the inverted arrangement shown in FIG. 8 or as shown in FIG. 2.

It is essential that the total liquid capacity of the openings 104 shown in FIGS. 7 and 8 be, at least, equal to the discharge capacity of the pipe 66. The same essential applies to the openings 106 shown in FIGS. 9 and 10. The impeller shown in FIGS. 7 to 10 may be identical with that shown in FIG. 2, except installed in the housing in inverted relation, which does not impair its pumping efficiency.

In each of the forms of my improved pump illustrated the impeller housing has a circular opening 16 in its bottom wall of sufficient diameter to permit the insertion and removal therethrough of the impeller 48, and in the form shown in FIGS. 1 to 5 this opening is utilized for admitting liquid to be pumped into the impeller housing, thereby dispensing with the necessity of having other liquid inlet openings in the housing.

In the pump structures shown in FIGS. 7 to 10 it would be possible to substitute a single elongated opening for the several smaller openings in the top and side walls as shown.

Obviously, various other changes or modifications in my improved pump may be made within the spirit and scope of my invention. Therefore, it should be understood that the embodiments of my invention shown and described are intended to be illustrative only, and restricted only by the appended claims.

I claim:

1. A pump of the class described comprising, in combination, a mounting plate, an impeller housing having top and bottom walls vertically spaced by a vertical wall and having, at least, one liquid inlet opening in one of its walls and a liquid outlet opening in its vertical wall, a centrifugal impeller in said housing in parallel relation with its top and bottom walls, the bottom wall of said housing having an opening therein of a sufficient diameter to permit the passage therethrough of said impeller, a single elongated member attached at its ends to said mounting plate and impeller housing for supporting said housing on said plate in distantly spaced relation therewith; a motor mounted on said plate and having a shaft connected with said impeller; means connected with said plate for suspending it and said housing in a horizontal position above a floor; said impeller housing having a through vertical bore in communication with the liquid outlet opening therein, a removable plug in the bottom end of said opening, a circular recess in the top of said impeller housing surrounding the vertical bore therein, a liquid discharge pipe sealed at its bottom end in said recess and terminating at its upper end in a downwardly tapered flange immediately above said mounting plate, said mounting plate having therein a guide opening through which said pipe projects; a cylindrical extension fitting attached to said mounting plate in concentric relation with said guide opening, said extension fitting having therein an upwardly tapered opening and a bore extending upwardly from said tapered opening and inclosing the flanged end of said discharge pipe; the guide opening in the mounting plate, the upwardly tapered seat and the bore in said extension fitting each being of a sufficient diameter to allow free longitudinal and lateral expansion therein of said flanged discharge pipe; and a liquid discharge pipe extension connected to the outer end of said extension fitting.

2. A pump as in claim 1 in which the liquid discharge pipe is provided with an insertable and removable liner section of refractory and corrosion resistant material extending from the removable plug in the bottom wall of the impeller housing to a plane above said extension fitting, said liner having an opening at its lower end in communication with the liquid outlet opening in the housing; and another liner section of like material inclosing the



7

outer end portion of the first liner section in telescopic and leak-proof relation therewith.

3. A pump as in claim 2 in which said liner sections are of resilient, refractory and corrosion resistant material.

**References Cited by the Examiner**

**UNITED STATES PATENTS**

2,181,973	12/1939	Jasberg	-----	103—114
2,304,849	12/1942	Ruthman	-----	103—111
2,381,824	8/1945	La Bour	-----	103—114
2,528,210	10/1950	Stewart	-----	103—114

8

2,732,809	1/1956	Mattingly et al.	-----	103—114
2,948,524	8/1960	Sweeney et al.	-----	103—103
3,010,402	11/1961	King	-----	103—111
3,048,384	8/1962	Sweeney et al.	-----	103—103
5 3,131,637	5/1964	Jennings	-----	103—103

**FOREIGN PATENTS**

1,238,364 7/1960 France.

SAMUEL LEVINE, *Primary Examiner.*

HENRY F. RADUAZO, *Examiner.*