



República Federativa do Brasil
Ministério do Desenvolvimento, Indústria
e do Comércio Exterior
Instituto Nacional da Propriedade Industrial

(21) PI 0904820-0 A2

(22) Data do Depósito: 18/06/2009

(43) Data da Publicação: 03/11/2015

(RPI 2339)



(54) Título: DISPOSITIVO DE SUPRESSÃO DE CORRENTE DE IRRUPÇÃO DE MAGNETIZAÇÃO PARA TRANSFORMADOR E MÉTODO DE CONTROLE DO MESMO

(51) Int. Cl.: H02H 7/04; H02H 3/26; H02H 9/02; H01H 33/59; H01H 33/70

(30) Prioridade Unionista: 20/06/2008 JP 2008-162474

(73) Titular(es): KABUSHIKI KAISHA TOSHIBA

(72) Inventor(es): TADASHI KOSHIZUKA, MINORU SAITO, KOICHI FUTAGAMI, HIROSHI KUSUYAMA, YOSHIMASA SATO

(74) Procurador(es): MONTAURY, PIMENTA, MACHADO & LIOCE

(57) Resumo: DISPOSITIVO DE SUPRESSÃO DE CORRENTE DE IRRUPÇÃO DE MAGNETIZAÇÃO PARA TRANSFORMADOR E MÉTODO DE CONTROLE DO MESMO. Para prover um dispositivo de supressão de corrente de um fluxo de magnetização para transformador e método de controle do mesmo, o qual calcula com exatidão o fluxo magnético residual quando um transformador instalado em um sistema não solidamente aterrado é interrompido pelos disjuntores, e que permite a supressão da corrente de irrupção de magnetização ocorrendo quando três disjuntores monofásicos ou disjuntores monofásicos são usados para fornecer simultaneamente energia às três fases do transformador, sem prover um disjuntor com um resistor ou outro equipamento para ampliar o disjuntor. O dispositivo tem meios de cálculo de fluxo magnético de estado constante para calcular o fluxo magnético de estado constante de linha-a-linha dos fornecimentos de energia trifásica, meios de cálculo de fluxo magnético residual para calcular o fluxo magnético residual primário de linha-a-linha do transformador quando os disjuntores interrompem o transformador, meios de detecção de fase para detectar uma fase na qual a polaridade e a(...)

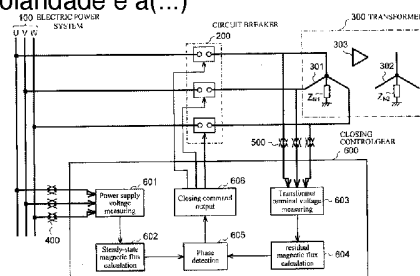

**"DISPOSITIVO PARA SUPRESSÃO DE CORRENTE DE IRRUPÇÃO DE
MAGNETIZAÇÃO PARA TRANSFORMADOR E MÉTODO DE CONTROLE DO
MESMO"**

TECHNICAL FIELD

5 This invention relates to a magnetizing inrush
current suppression technique for suppressing the
magnetizing inrush current which occurs when a power supply
is input to a transformer, especially to a magnetizing
inrush current suppression device for transformer and
10 control method of same, which accurately calculate the
residual magnetic flux and enable suppression of the
magnetizing inrush current without providing a circuit
breaker with a resistor or other equipment.

15 BACKGROUND ART

 When no-load energizing is performed by supplying
power to a transformer in a state in which there is
residual magnetic flux in the transformer core, a large
magnetizing inrush current may flow. Generally, the
20 magnitude of this magnetizing inrush current can be greater
than or equal to several times the rated load current of
the transformer. Therefore, such a magnetizing inrush
current flows, resulting in that the system voltage
fluctuates, and when this voltage fluctuation is large,
25 consumers can be affected.

 Accordingly, as a method of the prior art for
suppressing magnetizing inrush currents, for example, a
magnetizing inrush current suppression method is proposed
in which a circuit breaker with a resistor, formed by
30 connecting in series an closing resistor and a contact, is
connected in parallel with one of two main circuit breaker
arranged side by side, and power is turned on to this
circuit breaker with a resistor in advance of main contact
of the two main circuit breaker (see Patent Document 1).

Further, a method is known in which, when a three-phase transformer of a directly grounded system is supplied with power using three single-phase circuit breakers, one arbitrary phase is supplied with power in advance, and thereafter the remaining two phases are supplied with power, to suppress magnetizing inrush currents (see Non-patent Document 1).

Patent Document 1: Japanese Patent Application Laid-open No. 2002-75145, "Gas Circuit Breaker with Device for Suppression of Magnetizing Inrush Currents"

Patent Document 2: Japanese Patent No. 3,804,606

Non-patent Document 1: IEEE Trans., Vol. 16, No. 2, 2001, "Elimination of Transformer Inrush Currents by Controlled Switching -Part I: Theoretical Considerations"

In the case of the magnetizing inrush current suppression method disclosed in the above-described Patent Document 1 employing a circuit breaker with a resistor, which is formed by connecting in series an closing resistor and a contact, because it is necessary to specially add a circuit breaker with a resistor to the ordinary circuit breaker, in terms of the circuit breaker as a whole, larger equipment size is undeniable.

Moreover, the magnetizing inrush current suppression method in the above-described Non-patent Document 1 in which a transformer of an effectively grounded system is supplied with power by single-phase type, namely, phase segregated operation-type circuit breakers, has a drawback that it is impossible to suppress the magnetizing inrush current which occurs to a transformer of a non-effectively grounded system. Specifically, when phase segregated operation-type circuit breakers supply power to energize a no-load transformer installed in a non-effectively grounded system, because closing of one-phase circuit breaker can not apply voltage to transformer windings, closing of the second and third phases follows

the same condition as three-phase simultaneous closing, resulting in that it is impossible to suppress the magnetizing inrush current.

Further, it is essential that, when suppressing magnetizing inrush currents at the time of supplying power of transformer, the magnitude of the residual magnetic flux when the transformer is shut off be ascertained, from a relation with magnetic saturation of the transformer core. However, as described above, when phase segregated operation-type circuit breakers supply power to energize a no-load transformer installed in a non-effectively grounded system, if the circuit breakers shut off at the zero point the magnetizing current flowing in the no-load transformer, after shutting off the first phase a zero-phase voltage appears, and after shutting of the second and third phases the zero-phase voltage becomes a DC voltage and remains on the transformer.

Consequently when the voltage to ground at each of the transformer terminals on the side shut off by the circuit breakers is being measured, the above-described DC voltage is measured after shutoff. Therefore, the residual magnetic flux in the transformer core can not be accurately calculated by integration of the voltage to ground of each terminal.

For example, Fig. 3 shows a phenomenon that, when a transformer in a non-effectively grounded system is shut off, a DC voltage occurs in the primary terminal voltage. Especially, Fig. 3 (b) and (c) show the transformer primary voltage to ground and the magnetic flux calculated by integrating the voltage to ground when circuit breakers shut off the transformer the primary side of which is a Y connection and a neutral point is non-grounded. Further, as shown in Fir. 3 (b), after the circuit breakers shut off the current, a DC voltage occurs in the transformer primary voltage to ground. The voltage of the Y-connected neutral

point is also the same.

Here, if the residual magnetic flux is calculated by integrating the transformer terminal voltages 4 to 6, because the occurred DC voltage is to be calculated, as shown in Fig. 3 (c), the residual magnetic fluxes 33 to 35 of each phase increase as time passes, and finally diverge. In other words, when the magnetic fluxes are calculated by integrating the transformer terminal voltages 4 to 6, the residual magnetic flux can not be accurately calculated.

10

DISCLOSURE OF THE INVENTION

This invention was proposed in order to solve the above-described problems, and has as an object the provision of a magnetizing inrush current suppression device for transformer and control method of same, which accurately calculates the residual magnetic flux when a transformer installed in an electric power system, more particularly installed in a non-effectively grounded system, is shut off by circuit breakers, and which enables suppression of the magnetizing inrush current occurring when three single-phase circuit breakers or phase segregated operation-type circuit breakers are used for simultaneously supplying power to three phases of the transformer, without providing a circuit breaker with a resistor or other equipment to enlarge the circuit breaker.

In order to attain the above object, the invention provides a magnetizing inrush current suppression device for transformer, to suppress a magnetizing inrush current occurring at the start of energizing of a three-phase transformer the primary windings of which are connected in a Y connection or Δ connection and the secondary windings or tertiary windings of which are Δ -connected, when each of three-phase power supplies are input to each phase of the three-phase transformer by means

30

of each of three-phase circuit breakers, the device having:
steady-state magnetic flux calculation means for
calculating the line-to-line steady-state magnetic flux of
the three-phase power supplies; residual magnetic flux
5 calculation means for calculating the primary line-to-line
residual magnetic flux of the transformer when the circuit
breakers shut off the transformer; phase detection means
for inputting the steady-state magnetic flux calculated by
the steady-state magnetic flux calculation means and the
10 residual magnetic flux calculated by the residual magnetic
flux calculation means to detect a phase at which the
polarity and magnitude of the magnetic fluxes coincide for
each line-to-line; and closing control means for firstly
causing only two-phase of the circuit breakers, which are
15 connected with the line-to-line where the polarity and
magnitude of the magnetic fluxes coincide, to close at a
phase detected by the phase detection means, and then
causing the remaining one-phase circuit breaker to close.

As an aspect of the invention, the steady-state
20 magnetic flux calculation means, converts the respective
phase voltages of the three-phase power supplies into line-
to-line voltages, and integrates the line-to-line voltages
to calculate the line-to-line steady-state magnetic flux,
or, directly measures respective line-to-line voltages of
25 the three-phase power supplies, and integrates the line-to-
line voltages to calculate the line-to-line steady-state
magnetic flux.

Further, the invention also provides a
magnetizing inrush current suppression device for
30 transformer, to suppress a magnetizing inrush current
occurring at the start of energizing of a three-phase
transformer the primary windings of which are connected in
a Y connection or Δ connection and the secondary windings
or tertiary windings of which are Δ -connected, when each of
35 three-phase power supplies are input to each phase of the

three-phase transformer by means of each of three-phase circuit breakers, the device having: steady-state magnetic flux calculation means for calculating the line-to-line steady-state magnetic flux of the three-phase power
5 supplies; residual magnetic flux calculation means for calculating any line-to-line residual magnetic flux of the primary, secondary or tertiary side of the transformer when the circuit breakers shut off the transformer; command
10 means for performing opening command for the circuit breakers; opening phase control means for controlling the opening phase of the circuit breakers into a regular interval by command from the command means; opening output
15 means for causing the circuit breaker to open at an opening phase of the regular interval controlled by the opening phase control means; measuring and holding means for measuring and holding the relation between the opening
20 phase of the circuit breaker, which has opened through the opening output means, and the line-to-line residual magnetic flux calculated by the residual magnetic flux calculation means at the time of the opening; phase
25 detection means, in the line-to-line the residual magnetic flux of which is held by the measuring and holding means and a predetermined value, for detecting a phase at which the polarity and magnitude of the steady-state magnetic
30 flux and residual magnetic flux of the line-to-line coincide; and closing control means for firstly causing only two-phase of the circuit breakers, which are connected with the line-to-line where the polarity and magnitude of the magnetic fluxes coincide, to close at a phase detected
35 by the phase detection means, and then causing the remaining one-phase circuit breaker to close.

As a result of applying this invention, a magnetizing inrush current suppression device for transformer and control method of same can be provided such
35 that it is possible to suppress the magnetizing inrush

current occurring when three single-phase circuit breakers or phase segregated operation-type circuit breakers are used for simultaneously supplying power to three phases of the transformer, without providing a circuit breaker with a resistor or other equipment to enlarge the circuit breaker.

BRIEF DESCRIPTION OF THE DRAWINGS

Fig. 1 is a block diagram showing the connection relation between a three-phase transformer, three-phase circuit breakers, and a closing controlgear in the first embodiment of the invention;

Fig. 2 is a waveform diagram showing the relation between the three-phase power supply phase voltages, line-to-line voltages, line-to-line steady-state magnetic fluxes, line-to-line residual magnetic fluxes, circuit breaker electrode-to-electrode voltages and closing target of two-phase circuit breakers in the first embodiment of the invention;

Fig. 3 (a) is a connection diagram showing a three-phase transformer in a non-effectively grounded system, and Fig. 3 (b) to (e) are waveform diagrams showing a phenomenon that after the circuit breakers shut off the three-phase transformer, a DC voltage occurs in the transformer neutral point, and the magnetic fluxes diverge by integrating the transformer terminal voltage in the first embodiment of the invention and prior art;

Fig. 4 is a waveform diagram showing suppression effect of the magnetizing inrush current in the first embodiment of the invention;

Fig. 5 (a) is a connection diagram showing a three-phase transformer in a non-effectively grounded system, and Fig. 5 (b) is a waveform diagram illustrating, when one-phase circuit breaker is caused to close, voltage variation of the other phase circuit breakers in supplying

power to the three-phase transformer in the first embodiment of the invention;

Fig. 6 is a waveform diagram showing the relation between the three-phase power supply phase voltages, line-to-line voltages, line-to-line steady-state magnetic fluxes, line-to-line residual magnetic fluxes, circuit breaker electrode-to-electrode voltages and closing target of two-phase circuit breakers in the second embodiment of the invention;

Fig. 7 is an illustrative view of how to determine the phase as a first phase to be closed in the circuit breakers when the transformer of the directly grounded system of prior art is to be supplied with power;

Fig. 8 is a figure showing the relation between the voltages to ground and line-to-line voltage of the transformer primary and secondary side in the third embodiment of the invention;

Fig. 9 is a block diagram showing the connection relation between a three-phase transformer, three-phase circuit breakers, and an opening/closing controlgear in the fourth embodiment of the invention;

Fig. 10 is a waveform diagram showing the relation between the opening phase and each line-to-line residual magnetic flux when the three single-phase transformers are connected in Y and Δ connections, and are shut off by the circuit breakers in the fourth embodiment of the invention.

EXPLANATION OF SYMBOLS

- 1 to 3 Circuit breaker electrode-to-electrode voltages (U phase, V phase, W phase)
 4 to 6 Power supply phase voltages (U phase, V phase, W phase)
 7 to 9 Line-to-line voltages (UV, VW, WU)

- 10 to 12 Steady-state magnetic flux obtained by
integrating the line-to-line voltage (UV, VW, WU)
- 13 to 15 Line-to-line residual magnetic flux (UV, VW, WU)
- 20 Closing target of two-phase circuit breakers
- 5 21 Dispersion of closing target caused by pre-arcing and
dispersion of action
- 22 Pre-arcing electric discharge voltage
- 23 Dispersion of pre-arcing electric discharge voltage
- 25 Neutral point voltage
- 10 30 to 32 Each transformer phase magnetic flux (U phase, V
phase, W phase)
- 33 to 35 Each transformer phase residual flux (U phase, V
phase, W phase)
- 37 to 39 Each transformer phase exciting current (U phase,
15 V phase, W phase)
- 40 Closing target point of the remaining one-phase
circuit breaker
- 41 V phase voltage when U phase of the circuit breaker
200 closes at the point 20
- 20 42 W phase voltage when U phase of the circuit breaker
200 closes at the point 20
- 50 Closing target region when pre-arcing is under
consideration
- 51 Inappropriate region for closing of the circuit
25 breaker which includes an intersection point of steady-
state magnetic flux with residual magnetic flux
- 52 Circuit breaker electrode-to-electrode voltage
- 53 Steady-state magnetic flux
- 54 Residual magnetic flux
- 30 60 to 62 Transformer Δ side line-to-line voltages (UV, VW,
WU)
- 63 to 65 Transformer Δ side each phase voltages (U phase,
V phase, W phase)
- 70 to 72 Line-to-line residual magnetic flux depending on
35 opening phase (UV, VW, WU)

- 100 Electric power system (power supply busbar)
- 200 Circuit breaker
- 300 Three-phase transformer
- 301 Primary windings
- 5 302 Secondary windings
- 303 Tertiary windings
- 350 Electrostatic capacity
- 400 Power supply voltage measuring device
- 500 Transformer terminal voltage measuring device
- 10 500A Detachable transformer terminal voltage measuring device
- 600 Closing controlgear
- 600A Closing/opening controlgear
- 601 Power supply voltage measuring means
- 15 602 Steady-state magnetic flux calculation means
- 603 Transformer terminal voltage measuring means
- 604 Residual magnetic flux calculation means
- 605 Phase detection means
- 606 Closing command control means
- 20 607 Opening phase-residual magnetic flux relation measuring and holding means
- 608 Opening phase control means
- 609 Opening command output means

25 BEST MODE FOR CARRYING OUT THE INVENTION

[First embodiment]

Next, the configuration, operation and effect of a magnetizing inrush current suppression device for transformer as a first embodiment of the invention is explained below referring to Fig. 1 to Fig. 5. Here, Fig. 1 is a block diagram showing the connection relation between a three-phase transformer, three-phase circuit breakers, and a closing controlgear which performs closing command to the main contact of each circuit breaker. Fig.

2 is a waveform diagram showing the relation between the circuit breaker electrode-to-electrode voltages for supplying power to the transformer, power supply phase voltages, line-to-line voltages, line-to-line steady-state magnetic fluxes, and line-to-line residual magnetic fluxes.

Further, Fig. 3 is a figure showing a phenomenon that, when a transformer in a non-effectively grounded system is shut off, a DC voltage occurs in the primary terminal voltage. Fig. 4 is a waveform diagram showing variation of transformer primary terminal voltages, line-to-line voltages, line-to-line magnetic flux, and transformer exciting current when a 3.3 kV - 415 V - 300 kVA transformer has Y- Δ connections, with simulating the conditions of non-effectively grounded system, U phase and V phase circuit breakers 200 are closed at closing target 20, after that, the remaining W phase circuit breaker 200 is closed at closing target 40. Fig. 5 is a waveform diagram showing, when only one-phase circuit breaker is caused to close, electrode-to-electrode voltage variation of the remaining two phase circuit breakers in supplying power to the three-phase transformer in a non-effectively grounded system.

[Configuration]

In Fig. 1, 100 is a busbar of the electric power system (also called a power supply busbar), and 200 is three-phase circuit breakers and phase segregated operation-type. 300 is a three-phase transformer, to which the power supply busbar 100 is input or shut off by the three-phase circuit breakers 200, as an example, the primary windings 301 and secondary windings 302 are Y-connected, and the tertiary windings 303 are Δ -connected. Zn1 and Zn2 are respectively impedances to ground the neutral points of the primary windings 301 and secondary windings 302.

400 is a power supply voltage measuring device, comprising a VT or similar, to measure the voltages of respective phases (U, V, W) of the power supply busbar 100. 500 is a transformer terminal voltage measuring device, 5 comprising a VT or similar, to measure the terminal voltages of each primary-side phase (U, V, W) of the three-phase transformer 300. 600 is a closing controlgear which outputs a closing command to the main contacts of the circuit breakers 200, for example, which is embodied by a 10 digital arithmetic and control unit having a CPU.

In the closing controlgear 600, 601 is power supply voltage measuring means for capturing and measuring the power supply voltages of respective phases (phases U, V, W) output from the VT or other power supply voltage 15 measuring device 400. 602 is steady-state magnetic flux calculation means for calculating each line-to-line steady-state magnetic flux, by converting each of the phase voltages measured by the power supply voltage measuring means 601 into line-to-line voltage, and integrating the 20 line-to-line voltage.

603 is transformer terminal voltage measuring means for capturing and measuring the transformer terminal voltages for respective phases (phases U, V, W) output from the transformer terminal voltage measuring device (VT) 500. 25 604 is residual magnetic flux calculation means for calculating each line-to-line residual magnetic flux, by converting each of the phase voltages measured by the transformer terminal voltage measuring means 603 into line-to-line voltage, and integrating the line-to-line voltage.

605 is phase detection means for taking input, 30 for each line-to-line (UV, VW, WU), of the output signals of the steady-state magnetic flux calculation means 602 and the output signals of the residual magnetic flux calculation means 604, and for detecting phases at which 35 the line-to-line steady-state magnetic flux and residual

magnetic flux have the same polarity and magnitude. Further, the phase detection means 605, when two-phase circuit breakers 200 have been closed prior to the other phase by the closing command control means 606 described later, detects a phase of a time point at which the two-phase line-to-line voltages become zero simultaneously.

606 is closing command output means for taking input, for three phases, of the output signals from the phase detection means 605, and for outputting a closing command to the operation mechanism driving the main contacts of the circuit breakers 200 such that two-phase circuit breakers 200 are closed prior to the remaining one-phase and closing of the remaining one-phase is delayed.

[Action]

Next, an example of action of the first embodiment having the above-described configuration is explained below referring to Fig. 2. In Fig. 2, 4 to 6 are power supply voltages for respective phases (phases U, V, W). The phase voltages 4 to 6 are measured by the power supply voltage measuring means 601. 7 to 9 are voltages for each line-to-line obtained by converting the phase voltages 4 to 6 for respective phases. 10 to 12 are the steady-state magnetic flux for each line-to-line calculated by integrating each of the line-to-line voltages 7 to 9.

Further, 13 to 15 plotted by invariable straight line are the residual magnetic fluxes for each line-to-line (UV, VW, WU) of the primary-side of the three-phase transformer 300 calculated by the residual magnetic flux calculation means 604. The example of Fig. 2 shows a state in which the transformer UV residual magnetic flux 13 is of positive polarity and the maximum value, and the VW and WU residual magnetic fluxes 14 and 15 are of negative polarity and the same value (half of the residual magnetic flux 13)

Firstly, the power supply voltage measuring means

601 measures the phase voltages 4 to 6 for respective phases of the power supply busbar 100 through the power supply voltage measuring device 400, and the steady-state magnetic flux calculation means 602 converts each of the
5 phase voltages 4 to 6 into each of the line-to-line voltages 7 to 9, and integrates the line-to-line voltages 7 to 9 to calculate the UV, VW, and WU line-to-line steady-state magnetic fluxes 10 to 12. Alternatively, a method can be performed in which the phase voltages 4 to 6 are
10 integrated to calculate the steady-state magnetic fluxes for respective phases, and the calculated steady-state magnetic fluxes of respective phases are converted into the line-to-line steady-state magnetic fluxes 10 to 12.

The transformer terminal voltage measuring means
15 603 measures the transformer terminal voltages for respective phases (phases U, V, W) of the primary-side through the transformer terminal voltage measuring device 500, and the residual magnetic flux calculation means 604 converts each of the phase voltages measured by the
20 transformer terminal voltage measuring means 603 into each of the UV, VW, and WU line-to-line voltages, and integrates the line-to-line voltages to calculate the UV, VW, and WU line-to-line residual magnetic fluxes 13 to 15. Alternatively, a method can be performed in which the
25 respective phase voltages measured by the transformer terminal voltage measuring means 603 are integrated to calculate the residual magnetic fluxes for respective phases, and the calculated residual magnetic flux of respective phases are converted into the line-to-line
30 residual magnetic fluxes 13 to 15.

The phase detection means 605 receives, for each line-to-line, the output signals of the steady-state magnetic flux calculation means 602 and the output signals of the residual magnetic flux calculation means 604, and
35 detects phases at which the obtained steady-state magnetic

flux and primary line-to-line residual magnetic flux of the transformer 300 have the same polarity and magnitude. In Fig. 2, in the case of the UV line-to-line in which the line-to-line residual magnetic flux is the maximum value, because the intersection point of the line-to-line steady-state magnetic flux 10 with the line-to-line residual magnetic flux 13 is the point 20, the phase detection means 605 detects the point 20.

Further, the phase detection means 605, when two-phase circuit breakers 200 have been closed prior to the other phase by the closing command control means 606, detects a phase of a time point at which the two-phase line-to-line voltages become zero simultaneously. In other words, in the case of Fig. 4, the phase of the point 40 is detected, at which the U phase and V phase line-to-line voltages of the circuit breakers 200 become zero simultaneously.

The closing command control means 606, at the phase at which the line-to-line steady-state magnetic flux and residual magnetic flux have the same polarity and magnitude, closes the two-phase circuit breakers 200 connected with the line-to-line prior to the other phase. In other words, the closing command control means 606 causes the U phase and V phase the circuit breakers 200 to close simultaneously both the two phases at the point 20. And then the closing command control means 606 causes the remaining one-phase or W phase circuit breaker 200 to close at the point 40.

[Advantageous effect]

(a) The above-described first embodiment is different from prior art in which a DC voltage occurs in the transformer primary voltage to ground after the circuit breakers has shut off the current, and the residual magnetic flux calculated by integrating the transformer primary voltage

diverges, affected by this, the residual magnetic flux can not be accurately calculated. In other words, as a result of applying the first embodiment, the residual magnetic flux can be accurately calculated without being affected by the DC voltage, and thereby without divergence of the magnetic flux. Specifically, as shown in Fig. 3 (d) and (e), in the first embodiment, the voltage to ground is not directly integrated to calculate the residual magnetic flux, but the line-to-line voltage calculated from the voltage to ground, the calculated line-to-line voltage is integrated to calculate the line-to-line residual magnetic flux. Alternatively, even if the voltage to ground is integrated to calculate the residual magnetic flux, ultimately the line-to-line residual magnetic flux is calculated from the residual magnetic flux obtained by integration.

For more detailed explanation, as is clear from the DC voltage 25 of Fig. 3 (b), after shut off by the circuit breakers, the transformer primary voltages to ground for respective phases is DC voltages having the same magnitude. Here, for example, UV line-to-line voltage is obtained by subtracting the V phase voltage to ground from the U phase voltage to ground, the line-to-line voltages 7 to 9 are calculated from the differences of the primary voltages to ground, therefore, the effect of the DC voltage as described above does not appear in the line-to-line voltages 7 to 9. In other words, by integrating the line-to-line voltages in which the effect of the DC voltage does not appear, the residual magnetic fluxes 13 to 15 can be calculated such that the magnetic fluxes do not diverge.

Consequently, as a result of applying the first embodiment, if the line-to-line voltages are integrated to determine the relation between steady-state magnetic flux and residual magnetic flux, without being affected by the DC voltage occurring after the transformer has been shut off, namely, a neutral point voltage, the phase, at which

the line-to-line steady-state magnetic flux and residual magnetic flux have the same polarity, and at which the subsequent closing of circuit breakers 200 is performed, can be accurately determined.

5 In Fig. 3, a state is shown in which there is no transformer neutral point impedance. However, in a non-effectively grounded system, there are cases in which an impedance such as a resistance of large value is connected to the transformer neutral point, and in this case also a
10 DC voltage appears at the transformer neutral point. Therefore, as a result of applying the first embodiment described above, by means of integrating the line-to-line voltages to determine the relation between steady-state magnetic flux and residual magnetic flux, the closing phase,
15 at which the circuit breakers 200 are closed, can be accurately determined, without being affected by the neutral point voltage.

(b) The first embodiment, which has effects described
20 above, enables suppression of a large magnetizing inrush current as shown in Fig. 4. As described above, Fig. 4 is a waveform diagram showing variation of transformer primary terminal voltages, line-to-line voltages, line-to-line magnetic flux, and transformer exciting current when a 3.3
25 kV - 415 V - 300 kVA transformer has Y- Δ connections, with simulating the conditions of non-effectively grounded system, U phase and V phase circuit breakers 200 are closed at closing target 20, after that, the remaining W phase circuit breaker 200 is closed at closing target 40. In Fig.
30 4, the line-to-line residual magnetic fluxes are the same as those of Fig. 2. In other words, Fig. 4 shows a state in which the UV residual magnetic flux is of positive polarity and the maximum value, and the VW and WU residual magnetic fluxes are of negative polarity and half of the UV
35 residual magnetic flux.

In Fig. 4, after the U phase and V phase circuit breakers 200 have been caused to close simultaneously at the point 20 which is a closing target, a very little exciting currents 37 and 38 flow in the transformer 300. In other words, only the U phase and V phase exciting currents flows, while the W phase exciting current does not flow. Subsequently, when the remaining W phase circuit breaker 200 is caused to close at the point 40, in the W phase also an exciting current 39 flows.

Specifically, after the U phase and V phase of circuit breakers 200 have been caused to close simultaneously both the two phases at the closing target 20, a voltage of the line-to-line voltage $\sqrt{3}e$ is applied between the U phase and V phase terminals of the transformer 300. In other words, because a voltage is not applied to the W phase, a voltage of $\sqrt{3}e/2$ is applied to the transformer U phase windings and V phase windings. This is also shown waveforms 4 and 5 of voltages to ground which are shown in Fig. 3.

Therefore, as shown in Fig. 4, an exciting current between the points 20 and 40 is small, and after the point 40, three-phase voltages are applied, but an exciting current is 2.5 A level at a maximum, the magnetizing inrush current can be greatly suppressed.

(c) In the above-described Fig. 2, which is a waveform diagram showing the relation between the electrode-to-electrode voltage 1 of the U phase circuit breaker 200 for supplying power to the transformer 300, power supply phase voltages, line-to-line voltages, line-to-line steady-state magnetic fluxes, and line-to-line residual magnetic fluxes, the electrode-to-electrode voltage 1 of the U phase circuit breaker 200 shows a high voltage in the vicinity of the

peak value the point 20 which is a closing target. However, the electrode-to-electrode voltage 2 of the V phase circuit breaker 200 shows nearly zero, and this causes the fear that the closing time of the V phase is delayed compared with the U phase, and the two-phase circuit breakers 200 can not be caused to close simultaneously.

Here, in Fig. 5, under the condition that when a 3.3 kV - 415 V - 300 kVA transformer has Y- Δ connections, is a waveform diagram showing, when only one-phase circuit breaker 200 changes into a closing state, voltage variation of the other phases. If the U phase circuit breaker 200 has been caused to close, as shown as the V phase electrode-to-electrode voltage 41 and W phase electrode-to-electrode voltage 42, the electrode-to-electrode voltages of the other phases rise rapidly and become large accompanying transient oscillations.

In the case of the first embodiment as shown in Fig. 2, after only one-phase circuit breaker 200 has been caused to close at the point 20, the electrode-to-electrode voltages of the other phases rise rapidly and become large accompanying transient oscillations. This is caused by that charging of stray capacitance 350 across the unclosed phase terminals of the transformer and the circuit breaker 200 due to the voltage of the closed phase. After convergence of the transient oscillations, the electrode-to-electrode voltages of respective phases are of magnitude $\sqrt{3}$ p.u.

Thus it is understood that, when at the closing target point 20 in Fig. 2 the two-phase circuit breakers 200 are caused to close, after the electrical closing state which follows advance discharge caused by closing of one-phase circuit breaker, the other phase also immediately enters the closing state due to advance discharge, and the time difference in closing for the two-phases of the circuit breakers 200 can be made smaller.

In Fig. 2, 22 denotes the pre-arcing voltage which is the voltage of the above-described advance discharge during closing of the circuit breaker 200. As described above, when the circuit breaker is closed in the state in which voltages are applied across the circuit breaker electrodes, prior to mechanical contact of the circuit breaker contacts, advance discharge called pre-arcing occurs, resulting in an electrically closed state. The voltage at which pre-arcing occurs is larger for larger distances between contacts of the circuit breaker 200. Hence as shown in Fig. 2, the pre-arcing voltage 22 decreases along the time axis.

[Other embodiment relevant to first embodiment]

In the above-described first embodiment, the steady-state magnetic flux calculation means 602 calculates each line-to-line steady-state magnetic flux, by converting each of the phase voltages measured by the power supply voltage measuring means 601 into line-to-line voltage, and integrating the line-to-line voltage. However, the invention includes an embodiment in which the respective phase voltages measured by the power supply voltage measuring means 601 are integrated to calculate the steady-state magnetic fluxes of respective phases, and the steady-state magnetic fluxes of respective phases are converted into line-to-line steady-state magnetic fluxes. Further, the power supply voltage measuring device 400 such as VT often has a function that converts voltages to ground into line-to-line voltages within the device, in this case, it is unnecessary to convert voltages to ground into line-to-line voltages through the steady-state magnetic flux calculation means 602.

In the above-described first embodiment, the residual magnetic flux calculation means 604 calculates each line-to-line residual magnetic flux, by converting

each of the phase voltages measured by the transformer terminal voltage measuring means 603 into line-to-line voltage, and integrating the line-to-line voltage. However, the invention includes an embodiment in which each of the
5 phase voltages measured by the transformer terminal voltage measuring means 603 is integrated to calculate the residual magnetic flux of each terminal of the transformer 300, and the residual magnetic flux of each terminal is converted into line-to-line residual magnetic flux. Further, if the
10 transformer terminal voltage measuring device 500 such as VT has a function that converts a voltage to ground into line-to-line voltage within the device, it is unnecessary to convert a voltage to ground into line-to-line voltage through the residual magnetic flux calculation means 604.

15 In the above-described first embodiment, as shown in fig. 4, it is embodied that the closing point 40 is about 2 cycles after from the advance two-phase closing. However, the invention, for example, includes an embodiment in which the closing point is half cycle after from the
20 advance two-phase closing. The point 40 can be appropriately set in advance by performing in advance an analysis using EMTP and other pieces of software, or, measurement using an actual transformer.

Further, in the pre-arcing voltages shown in Fig. 2 and Fig. 5, generally, dispersion often appears, and when the circuit breaker 200 is to close, dispersion of closing time is caused by dispersion of action of the operation mechanism. Here, in Fig. 2, pre-arcing voltage, which includes the dispersion of the pre-arcing voltage and the
30 dispersion of closing time of the circuit breaker 200, is denoted by 23.

Consequently, the invention includes an embodiment of the closing controlgear 600, which controls the phase at which the circuit breaker 200, and
35 specifically, which acquires in advance the characteristics

of dispersion as described above to compensate with taking account of the characteristics of dispersion, and control the closing phase. As shown in Fig. 2, even if the closing point of the circuit breaker 200 has dispersion of pre-arc voltage as shown by the region 23, the difference between the line-to-line steady-state magnetic flux and residual magnetic flux does not become remarkably large, therefore, there is no obstacle to the effect that the embodiment enables suppression of large magnetizing inrush current.

[Second embodiment]

Next, a magnetizing inrush current suppression device for transformer as a second embodiment of the invention is explained below referring to Fig. 6. Here, Fig. 6 shows a modification of the waveform diagram of Fig. 2, in which the closing point of the circuit breaker has been changed.

[Configuration]

In the second embodiment, the connection relation between the three-phase transformer 300, three-phase circuit breakers 200, and closing controlgear 600, is the same as that of the first embodiment, therefore, the second embodiment has a common configuration with the first embodiment except for the following points.

The second embodiment is a embodiment in which the closing controlgear 600 is set such that, in the line-to-line where the residual magnetic flux is the maximum value among the line-to-line combinations of the three-phase transformer 300, as a phase at which the polarity and magnitude of the steady-state magnetic flux and residual magnetic flux coincide, the point 20' different from the point 20 in Fig. 2, is set as the target point for two-phase closing of the circuit breakers 200.

Specifically, the closing controlgear 600 is set such that the phase detection means 605, when taking input, for each line-to-line (UV, VW, WU), of the output signals of the steady-state magnetic flux calculation means 602 and
5 the output signals of the residual magnetic flux calculation means 604, detects the second phase in time order of all phases at which the line-to-line steady-state magnetic flux and residual magnetic flux obtained from the signals have the same polarity and magnitude. Needless to
10 say, the phase to be detected is not limited to the second in time order, another phase can be detected, at which the line-to-line steady-state magnetic flux and residual magnetic flux have the same polarity and magnitude.

15 [Action]

Next, an example of action of the second embodiment having the above-described configuration is explained below.

20 Firstly, similar to the first embodiment, the power supply voltage measuring means 601 measures the phase voltages 4 to 6 for respective phases through the power supply voltage measuring device 400, and the steady-state magnetic flux calculation means 602 converts each of the phase voltages 4 to 6 into each of the line-to-line
25 voltages 7 to 9, and integrates the line-to-line voltages 7 to 9 to calculate the line-to-line steady-state magnetic fluxes 10 to 12. Alternatively, a method can be performed in which the phase voltages 4 to 6 are integrated to calculate the steady-state magnetic fluxes for respective
30 phases, and the calculated steady-state magnetic fluxes of respective phases are converted into the line-to-line steady-state magnetic fluxes 10 to 12.

The transformer terminal voltage measuring means 603 measures the transformer terminal voltages for
35 respective phases (phases U, V, W) through the transformer

terminal voltage measuring device 500, and the residual magnetic flux calculation means 604 converts each of the phase voltages measured by the transformer terminal voltage measuring means 603 into each of the line-to-line voltages, and integrates the line-to-line voltages to calculate the UV, VW, and WU line-to-line residual magnetic fluxes 13 to 15. Alternatively, a method can be performed in which the phase voltages measured by the transformer terminal voltage measuring means 603 are integrated to calculate the residual magnetic fluxes for respective phases, and the calculated residual magnetic fluxes of respective phases are converted into the line-to-line residual magnetic fluxes 13 to 15.

As a feature of the second embodiment, the phase detection means 605 receives, for each line-to-line, the output signals of the steady-state magnetic flux calculation means 602 and the output signals of the residual magnetic flux calculation means 604, and detects the phase of the second point in time order of all points at which the obtained line-to-line steady-state magnetic flux and line-to-line residual magnetic flux of the transformer 300 have the same polarity and magnitude. In Fig. 6, in the case of the UV line-to-line in which the line-to-line residual magnetic flux is the maximum value, because the intersection points of the line-to-line steady-state magnetic flux 10 with the line-to-line residual magnetic flux 13 are the points 20 and 20', the phase detection means 605 detects the point 20' as the second point.

The closing command control means 606, at the phase of the second point in time order of all points at which the line-to-line steady-state magnetic flux and residual magnetic flux have the same polarity and magnitude, closes the two-phase circuit breakers 200 prior to the other phase. In other words, in Fig. 6, the closing

command control means 606 causes the U phase and V phase the circuit breakers 200 to close simultaneously both the two phases at the point 20'.

Further, the phase detection means 605, when two-phase
5 circuit breakers 200 have been closed prior to the other phase by the closing command control means 606, detects a phase of a time point at which the two-phase line-to-line voltages become zero simultaneously. In other words, the phase of the point 40 is detected, at which the U phase and
10 V phase line-to-line voltages of the circuit breakers 200 become zero simultaneously. And then the closing command control means 606 causes the remaining one-phase or W phase circuit breaker 200 to close at the point 40.

15 [Advantageous effect]

As a result of applying the second embodiment in which the two-phase circuit breakers 200 is closed at the phase of the second point in time order of all points at which the polarity and magnitude of the line-to-line
20 steady-state magnetic flux and residual magnetic flux coincide, for the same reason as the first embodiment, a large magnetizing inrush current can be suppressed (not shown in figures).

Further, in the second embodiment, as shown in
25 fig. 6, for a non-effectively grounded system transformer, the point 20' which is the second intersection point of the two intersection points of the steady-state magnetic flux with residual magnetic flux, can be set as a closing target of the circuit breakers 200. This can improve the degree
30 of freedom in closing target settings.

For example, when a effectively grounded system transformer is to be closed according to the method of Non-patent Document 1 cited as the prior art, one-phase circuit breaker is closed, and then the remaining two-phase circuit
35 breakers are closed. Here, with regard to determination of

closing phase for one-phase circuit breaker to be closed prior to the other phase, if taking account of an electric closing due to pre-arcing discharge according to Patent Document 2, as shown in Fig. 7, the region of the closing phase denoted by 50.

In Fig. 7, when a transformer the primary windings of which are grounded at neutral points is closed, how to determine the closing phase of the first phase to be closed is explained (see Patent Document 2). In other words, according to Patent Document 2, in the region 50, even if dispersion of pre-arcing or dispersion of action of circuit breakers exist, the difference between steady-state magnetic flux and residual magnetic flux at closing point can be made smaller.

However, as shown in Fig. 7, an intersection point of the steady-state magnetic flux with residual magnetic flux, namely, the point at which the steady-state magnetic flux and residual magnetic flux are of the same polarity and magnitude, also exists in the region 51, it is inappropriate to set the region 51 as a closing target, because, if taking account of the dispersion of pre-arcing or dispersion of action of circuit breakers, the difference between steady-state magnetic flux and residual magnetic flux at closing point is made larger. In other words, if closing is performed with setting the region 51 as a closing target, a large magnetizing inrush current may occur due to the difference between steady-state magnetic flux and residual magnetic flux.

On the other hand, as a result of applying the second embodiment of the invention, as described above, in a non-effectively grounded system, any of the two intersection points of the steady-state magnetic flux with residual magnetic flux, can be set as a closing target, resulting in an improvement of the degree of freedom in closing target settings.

Further, as shown in Fig. 6, in the second embodiment, the UV line-to-line steady-state magnetic flux 10 and residual magnetic flux 13 coincide at the point 20 as a closing target of the circuit breakers 200, but at the point 20', the V phase electrode-to-electrode voltage 2 of the circuit breakers 200 shows a value in the vicinity of the peak value and the U phase electrode-to-electrode voltage 1 shows nearly zero. However, for the same reason as the first embodiment, in the second embodiment, after the electrical closing state is caused by advance discharge of one-phase circuit breaker, the other phase also immediately enters the electrical closing state due to advance discharge, the two-phases closing of the circuit breakers 200 can be substantially performed.

15

[Other embodiment relevant to second embodiment]

In the second embodiment as described above, the phase detection means 605 within the closing controlgear 600, detects the phase of the second point in time order of all points at which the obtained line-to-line steady-state magnetic flux and line-to-line residual magnetic flux have the same polarity and magnitude. However, the invention includes the following embodiment.

Specifically, when taking input, for each line-to-line (UV, VW, WU), of the output signals of the steady-state magnetic flux calculation means 602 and the output signals of the residual magnetic flux calculation means 604, the phase detection means 605, when it detects phase points at which the line-to-line steady-state magnetic flux and residual magnetic flux obtained from the signals have the same polarity and magnitude, detects all phase points or predetermined number of phase points set in advance. The closing command control means 606, from phase points at which the line-to-line steady-state magnetic flux and residual magnetic flux have the same polarity and magnitude,

35

selects a desired point, for example, in the case of fig. 6, the point 20' the second intersection point 20' of the steady-state magnetic flux with residual magnetic flux, and causes the two-phase circuit breakers 200 to close at the selected point.

[Third embodiment]

Next, a magnetizing inrush current suppression device for transformer as a third embodiment of the invention is explained below referring to Fig. 8. Here, Fig. 8 shows the phase relations between the primary Y-side phase voltages and line-to-line voltages, and the secondary or tertiary Δ -side voltages to ground and line-to-line voltages.

[Configuration]

In the third embodiment, the connection relation between the three-phase transformer 300, three-phase circuit breakers 200, and closing controlgear 600, is the same as that of the first embodiment, therefore, the third embodiment has a common configuration with the first embodiment except for the following points.

The third embodiment is a embodiment in which, even if a voltage division device is not installed on the transformer primary Y side, and the transformer terminal voltage of the primary Y side cannot be measured by the transformer terminal voltage measuring means 603 through the transformer terminal voltage measuring device 500, by measuring the voltages to ground on the secondary or tertiary Δ connection side, the primary Y side line-to-line voltages can be calculated.

Specifically, even if a voltage division device is not installed on the transformer primary Y side, for the Δ side voltages to ground which are measured by the transformer terminal voltage measuring means 603, the

residual magnetic flux calculation means 604 inverts the polarities of the voltages or leaves them as they are, depending on the phase sequence relation between Y side and Δ side of the transformer 300 to calculate the primary Y side line-to-line voltages, and integrates the calculated line-to-line voltages to calculate the line-to-line residual magnetic flux.

[Action]

10 Next, an example of action of the third embodiment having the above-described configuration is explained below.

 Firstly, similar to the first embodiment, the power supply voltage measuring means 601 measures the phase voltages 4 to 6 for respective phases through the power supply voltage measuring device 400, and the steady-state magnetic flux calculation means 602 converts each of the phase voltages 4 to 6 into each of the line-to-line voltages 7 to 9, and integrates the line-to-line voltages 7 to 9 to calculate the line-to-line steady-state magnetic fluxes 10 to 12. Alternatively, a method can be performed in which the phase voltages 4 to 6 are integrated to calculate the steady-state magnetic fluxes for respective phases, and the calculated steady-state magnetic fluxes of respective phases are converted into the line-to-line steady-state magnetic fluxes 10 to 12.

 Here, in the third embodiment, the transformer terminal voltage measuring means 603 measures the Δ side voltages to ground through the transformer terminal voltage measuring device 500. The residual magnetic flux calculation means 604 inverts the polarities of the Δ side voltages to ground measured by the transformer terminal voltage measuring means 603 for all three phases, to calculate the primary Y side line-to-line voltages.

35 Specifically, in Fig. 8 (a) in which the phase

sequence relation on the Y-side and Δ -side is $+30^\circ$, for example, the Δ -side W phase voltage to ground 65 is directed opposite to the vector of the primary Y-side VW line-to-line voltage 8. The relations are similar between
5 the Δ -side V phase voltage to ground 64 and the Y-side UV line-to-line voltage 7, and between the Δ -side U phase voltage to ground 63 and the Y-side WU line-to-line voltage 9. In other words, the two vectors of each combination are directed opposite to each other. Therefore, if the Δ -side
10 voltages to ground are measured by the transformer terminal voltage measuring means 603, and the voltage polarities are inverted for all three phases by the residual magnetic flux calculation means 604, then the phase of the Δ side voltages to ground is the same as for the primary Y-side
15 line-to-line voltages.

Further, the residual magnetic flux calculation means 604 integrates the primary Y-side line-to-line voltages to calculate the line-to-line magnetic fluxes. Subsequent process is the same as that of the first
20 embodiment described above, the explanation thereof is omitted.

On the other hand, in Fig. 8 (b) in which the phase sequence relation on the Y-side and Δ -side is -30° , for example, the Δ -side V phase voltage to ground 64 is
25 directed in the same direction as the vector of the primary Y-side UV line-to-line voltage 7. The relations are similar between the Δ -side U phase voltage to ground 63 and the Y-side WU line-to-line voltage 8, and between the Δ -side W phase voltage to ground 65 and the Y-side VW line-
30 to-line voltage 8, in other words, the two vectors of each combination are directed in the same direction.

Therefore, if the Δ -side voltages to ground are measured by the transformer terminal voltage measuring means 603, and the voltage polarities are of the same
35 polarity for all three phases by the residual magnetic flux

calculation means 604, then the phase of the Δ side voltages to ground is the same as for the primary Y-side line-to-line voltages. Subsequent process is the same as the above-described process.

5

[Advantageous effect]

As a result of applying the third embodiment in which, even if a voltage division device is not installed on the transformer primary side, and the terminal voltage of the primary Y side cannot be measured by the transformer terminal voltage measuring means 603, by measuring the
10 voltages to ground on the Δ side, from the measured voltages, the primary line-to-line magnetic fluxes can be calculated. Therefore, even if under these circumstances,
15 a closing target of the circuit breakers 200 can be set similar to the first embodiment, a large magnetizing inrush current can be suppressed.

With regard to the DC voltage occurring after the transformer 300 has been shut off, namely, a neutral point
20 voltage, which is explained in the above-described embodiments, the neutral point voltage is a zero-phase voltage, as a result of this, the Δ side is not affected by the neutral point voltage. Consequently, by measuring the
25 Δ -side voltages to ground and adjusting the polarities for three-phase to calculate the primary Y-side line-to-line voltages, subsequently integrating the calculated values, the result can be acquired, which is the same as the result of the case in which the primary Y-side voltages to ground are measured to calculate the line-to-line voltages,
30 subsequently the calculated values are integrated to calculate the magnetic fluxes.

[Fourth embodiment]

Next, a magnetizing inrush current suppression
35 device for transformer as a fourth embodiment of the

invention is explained below referring to Fig. 9 and Fig. 10. Here, Fig. 9 is a block diagram showing the connection relation between a three-phase transformer, three-phase circuit breakers, and an opening/closing controlgear. Fig. 10 is a waveform diagram that, when the three single-phase transformers are connected in Y and Δ connections, and are shut off by the circuit breakers, shows an example of the line-to-line residual magnetic fluxes, which are calculated depending on the opening phase.

10

[Configuration]

In the fourth embodiment, as shown in Fig. 9, the power supply busbar 100, three-phase circuit breakers 200, and power supply voltage measuring device 400, is the same as that of the first embodiment, therefore, the fourth embodiment has a common configuration with the first embodiment in these points. However, the fourth embodiment is different from the first embodiment with regard to the following configuration of: three-phase transformer 300, closing/opening controlgear 600A as a modification of the closing controlgear 600, and detachable transformer terminal voltage measuring device 500A as a replacement for the fixed transformer terminal voltage measuring device 500.

In the fourth embodiment, with regard to the three-phase transformer 300, for example, the primary windings 301 are Y-connected, the secondary windings 302 are Δ -connected, and the tertiary windings 303 are Δ -connected.

Further, in the fourth embodiment, in ordinary operation, the transformer terminal voltage measuring device 500 is not installed for any of the primary terminal, secondary terminal, and tertiary terminal of the three-phase transformer 300. Instead of that, a detachable transformer terminal voltage measuring device 500A, which measures the terminal voltage, is connected with the

35

primary terminal.

The transformer terminal voltage measuring device 500A, as described later, is removed from the primary terminal in ordinary operation, and is connected with the primary terminal when the characteristics of the line-to-line residual magnetic fluxes as shown in Fig. 10 are measured. Alternatively, the transformer terminal voltage measuring device 500A can be permanently installed. Further, the transformer terminal voltage measuring device 500A can be connected with the secondary terminal or tertiary terminal.

Further, the fourth embodiment has features in which the closing/opening controlgear 600A as a modification of the closing controlgear 600, when taking input of output voltages of the transformer terminal voltage measuring device 500A, causes the circuit breakers 200 to open plural times and measures in advance the characteristics of each line-to-line residual magnetic flux of the transformer for the closing phase of the circuit breakers as shown in Fig. 10. The closing/opening controlgear 600A has a common configuration with the closing controlgear 600 as concerns the configuration of the power supply voltage measuring means 601 through the closing command control means 606, but is newly provided with opening phase-residual magnetic flux relation measuring and holding means 607 (corresponding to "command means" and "measuring and holding means" of the invention), opening phase control means 608, and opening command output means 609 (corresponding to "opening output means" of the invention).

The opening phase-residual magnetic flux relation measuring and holding means 607 gives the command to the opening phase control means 608 as described later, for causing the circuit breakers 200 to open plural times in a state of being temporarily connected with the transformer

terminal voltage measuring device 500A. Further, the opening phase-residual magnetic flux relation measuring and holding means 607 has functions of: acquiring the opening phase when the circuit breakers 200 open plural times
5 through the transformer terminal voltage measuring means 603, and acquiring the line-to-line residual magnetic flux during the opening operation from the residual magnetic flux calculation means 604, and measuring and holding the relation between the opening phase and the line-to-line
10 residual magnetic flux.

The opening phase control means 608 has functions of: inputting the output of the power supply voltage measuring means 601 and the opening command for the circuit breakers 200 from the opening phase-residual magnetic flux
15 relation measuring and holding means 607, and controlling the opening phase of the main contacts of the circuit breakers 200 into a regular interval. The opening command output means 609 outputs an opening command to the operation mechanism driving the main contacts of the
20 circuit breakers 200 such that the circuit breakers 200 open at the opening phase controlled into the regular interval by the opening phase control means 608.

[Action]

25 Next, an example of action of the fourth embodiment having the above-described configuration is explained below referring to Fig. 10. Once the circuit breakers 200 and the transformer 300 are installed in the electric power system, the circuit conditions of the
30 electric power system (in Fig. 9, the circuit conditions from the power supply busbar 100 to the three-phase transformer 300) are always the same. Therefore, it is supposed that if the phase at which the circuit breakers 200 open is a regular phase, then the value of each line-
35 to-line residual flux of the three-phase transformer 300 is

a regular value.

In the fourth embodiment, in ordinary operation, the transformer terminal voltage measuring device 500 is not installed for any of the primary terminal, secondary
5 terminal, and tertiary terminal of the three-phase transformer 300. Therefore, the circuit breakers 200 are caused to open plural times in a state in which the transformer terminal voltage measuring device 500A is temporarily connected with the transformer terminal, and
10 the characteristics of each line-to-line residual magnetic flux of the transformer are measured in advance for the closing phase of the circuit breakers as shown in Fig. 10.

Specifically, for example, in a state in which the 500A is temporarily connected with the primary terminal
15 of the three-phase transformer 300, the opening phase-residual magnetic flux relation measuring and holding means 607 gives a command to the opening phase control means 608 for causing the circuit breakers 200 to open plural times.

The opening phase control means 608, when
20 acquiring the opening command to the circuit breakers 200 from the opening phase-residual magnetic flux relation measuring and holding means 607, controls the opening phase of the main contacts of the circuit breakers 200 into a predetermined value. The opening command output means 609
25 outputs an opening command to the operation mechanism driving the main contacts of the circuit breakers 200 such that the circuit breakers 200 open at the opening phase of the predetermined value controlled by the opening phase control means 608.

30 When the circuit breakers 200 has been caused to open, the transformer terminal voltage measuring means 603 measures the primary terminal voltages of the transformer 300 through the transformer terminal voltage measuring device 500A, and the opening phase of the measured voltages
35 are sent to the opening phase-residual magnetic flux

relation measuring and holding means 607. At the same time, the residual magnetic flux calculation means 604 converts the terminal voltages of respective phases measured by the transformer terminal voltage measuring means 603 into each
5 of the line-to-line voltages, and integrates the line-to-line voltages to calculate the line-to-line residual magnetic fluxes. Alternatively, a method can be performed in which the phase voltages measured by the transformer terminal voltage measuring means 603 are integrated to
10 calculate the residual magnetic fluxes for respective phases, and the calculated residual magnetic fluxes of respective phases are converted into the line-to-line residual magnetic fluxes.

The opening phase-residual magnetic flux relation
15 measuring and holding means 607 acquires the opening phase of the voltages sent from the transformer terminal voltage measuring means 603, and acquires also the line-to-line residual magnetic flux from the residual magnetic flux calculation means 604, to measure and hold the relation
20 between the opening phase and the line-to-line residual magnetic flux. The above-described process is repeated by the command from the opening phase-residual magnetic flux relation measuring and holding means 607, for causing the circuit breakers 200 to open plural times, resulting in
25 that the characteristics of the line-to-line residual magnetic fluxes can be acquire in advance, which are calculated depending on the opening phase of the regular interval as shown in Fig. 10.

By using the line-to-line residual magnetic
30 fluxes acquired in advance by the above-described process, a process the same as that of the first embodiment is performed. In other words, the phase detection means 605 detects phases at which, for each line-to-line, the steady-state magnetic fluxes from the steady-state magnetic flux
35 calculation means 602 and the residual magnetic fluxes

acquired in advance have the same polarity and magnitude. The two-phase circuit breakers 200 are caused to close at the detected phase point through the closing command control means 606. Among the residual magnetic fluxes
5 acquired in advance, the residual magnetic flux of line-to-line showing the maximum value or minimum value is used for the subsequent part of the process the same as that of the first embodiment.

Further, in the process as described above in which
10 h the characteristics of the line-to-line residual magnetic fluxes are measured in advance, it is important to obtain the relation between the opening phase and the line-to-line residual magnetic flux. Therefore, it is unnecessary to measure the characteristics of the residual
15 magnetic fluxes depending on the detailed opening phase of the regular interval as shown in Fig. 10.

[Advantageous effect]

As a result of applying the fourth embodiment as
20 described above, after the circuit breakers 200 shut off the transformer 300, the characteristics of the residual magnetic fluxes can be acquire in advance in a state in which the transformer terminal voltage measuring device 500A is temporarily connected with the transformer terminal.
25 Therefore, if the voltage information of the power supply voltage measuring device 400, even if the transformer terminal voltage measuring device 500 is not installed, the steady-state magnetic fluxes of the three-phase transformer 300 can be calculated. By using the steady-state magnetic
30 fluxes and the line-to-line residual magnetic fluxes acquired in advance, the closing phase of the circuit breakers 200 can be controlled.

In other words, for busbar or the like in a substation, the power supply voltage measuring device 400
35 such as measuring device for busbar voltage is necessarily

installed, for this reason, if the voltage information of the power supply voltage measuring device 400, even if the transformer terminal voltage measuring device 500 is not installed, the steady-state magnetic fluxes of the three-phase transformer can be calculated. Therefore, based on the relation between the steady-state magnetic fluxes and the line-to-line residual magnetic fluxes acquired in advance, the same as the first embodiment, the fourth embodiment also takes effect which enables suppression of large magnetizing inrush current.

Further, as described above, since the characteristics of the line-to-line residual magnetic fluxes can be acquired in advance, even if the terminal voltages of the three-phase transformer 300 cannot be measured for each opening operation, the relation between the steady-state magnetic fluxes and residual magnetic fluxes can be obtained, and the residual magnetic flux for each line-to-line can be estimated.

REIVINDICAÇÕES

1. A magnetizing inrush current suppression device for transformer, to suppress a magnetizing inrush current occurring at the start of energizing of a three-phase transformer the primary windings of which are connected in a Y connection or Δ connection and the secondary windings or tertiary windings of which are Δ -connected, when each of three-phase power supplies are input to each phase of the three-phase transformer by means of each of three-phase circuit breakers, comprising:

steady-state magnetic flux calculation means for calculating the line-to-line steady-state magnetic flux of the three-phase power supplies;

residual magnetic flux calculation means for calculating the primary line-to-line residual magnetic flux of the transformer when the circuit breakers shut off the transformer;

phase detection means for inputting the steady-state magnetic flux calculated by the steady-state magnetic flux calculation means and the residual magnetic flux calculated by the residual magnetic flux calculation means to detect a phase at which the polarity and magnitude of the magnetic fluxes coincide for each line-to-line; and

closing control means for firstly causing only two-phase of the circuit breakers, which are connected with the line-to-line where the polarity and magnitude of the magnetic fluxes coincide, to close at a phase detected by the phase detection means, and then causing the remaining one-phase circuit breaker to close.

2. The magnetizing inrush current suppression device for transformer according to Claim 1, wherein

the steady-state magnetic flux calculation means converts the respective phase voltages of the three-phase

power supplies into line-to-line voltages, and integrates the line-to-line voltages to calculate the line-to-line steady-state magnetic flux.

5 3. The magnetizing inrush current suppression device for transformer according to Claim 1, wherein

 the steady-state magnetic flux calculation means directly measures respective line-to-line voltages of the three-phase power supplies, and integrates the line-to-line
10 voltages to calculate the line-to-line steady-state magnetic flux.

 4. The magnetizing inrush current suppression device for transformer according to Claim 1, wherein

15 the residual magnetic flux calculation means directly measures respective voltages to ground of respective phase of the Δ -connected secondary or tertiary windings in the three-phase transformer, and integrates the measured voltages to ground to calculate the primary line-
20 to-line residual magnetic flux.

 5. A magnetizing inrush current suppression device for transformer, to suppress a magnetizing inrush current occurring at the start of energizing of a three-
25 phase transformer the primary windings of which are connected in a Y connection or Δ connection and the secondary windings or tertiary windings of which are Δ -connected, when each of three-phase power supplies are input to each phase of the three-phase transformer by means
30 of each of three-phase circuit breakers, comprising:

 steady-state magnetic flux calculation means for calculating the line-to-line steady-state magnetic flux of the three-phase power supplies;

 residual magnetic flux calculation means for
35 calculating any line-to-line residual magnetic flux of the

primary, secondary or tertiary side of the transformer when the circuit breakers shut off the transformer;

command means for performing opening command for the circuit breakers;

5 opening phase control means for controlling the opening phase of the circuit breakers into a regular interval by command from the command means;

opening output means for causing the circuit breaker to open at an opening phase of the regular interval controlled by the opening phase control means;

10 measuring and holding means for measuring and holding the relation between the opening phase of the circuit breaker, which has opened through the opening output means, and the line-to-line residual magnetic flux calculated by the residual magnetic flux calculation means at the time of the opening;

phase detection means, in the line-to-line the residual magnetic flux of which is held by the measuring and holding means and a predetermined value, for detecting a phase at which the polarity and magnitude of the steady-state magnetic flux and residual magnetic flux of the line-to-line coincide; and

20 closing control means for firstly causing only two-phase of the circuit breakers, which are connected with the line-to-line where the polarity and magnitude of the magnetic fluxes coincide, to close at a phase detected by the phase detection means, and then causing the remaining one-phase circuit breaker to close.

30 6. The magnetizing inrush current suppression device for transformer according to Claim 1 or 5, wherein

the closing control means, when a predetermined time has passed after causing the two-phase of the circuit breakers to close, causing the remaining one-phase circuit breaker to close.

35

7. A control method of magnetizing inrush current suppression device for transformer, to suppress a magnetizing inrush current occurring at the start of energizing of a three-phase transformer the primary windings of which are connected in a Y connection or Δ connection and the secondary windings or tertiary windings of which are Δ -connected, when each of three-phase power supplies are input to each phase of the three-phase transformer by means of each of three-phase circuit breakers, comprising the steps of:

calculating the line-to-line steady-state magnetic flux of the three-phase power supplies;

calculating the primary line-to-line residual magnetic flux of the transformer when the circuit breakers shut off the transformer;

detecting a phase at which the polarity and magnitude of the line-to-line steady-state magnetic flux and residual magnetic flux coincide; and

firstly causing only two-phase of the circuit breakers, which are connected with the line-to-line where the polarity and magnitude of the magnetic fluxes coincide, to close at a phase where coincidence of the polarity and magnitude has been detected, and then causing the remaining one-phase circuit breaker to close.

8. A control method of magnetizing inrush current suppression device for transformer, to suppress a magnetizing inrush current occurring at the start of energizing of a three-phase transformer the primary windings of which are connected in a Y connection or Δ connection and the secondary windings or tertiary windings of which are Δ -connected, when each of three-phase power supplies are input to each phase of the three-phase transformer by means of each of three-phase circuit

breakers, comprising the steps of:

calculating the line-to-line steady-state magnetic flux of the three-phase power supplies;

5 calculating any line-to-line residual magnetic flux of the primary, secondary or tertiary side of the transformer when the circuit breakers shut off the transformer;

10 controlling the opening phase of the circuit breakers into a regular interval by opening command for the circuit breakers;

causing the circuit breaker to open at an opening phase of the controlled regular interval;

15 measuring and holding the relation between the opening phase of the circuit breaker, which has opened, and the line-to-line residual magnetic flux at the time of the opening;

20 in the line-to-line the held residual magnetic flux of which is a predetermined value, detecting a phase at which the polarity and magnitude of the line-to-line steady-state magnetic flux and residual magnetic flux coincide; and

25 firstly causing only two-phase of the circuit breakers, which are connected with the line-to-line where the polarity and magnitude of the magnetic fluxes coincide, to close at a phase where coincidence of the polarity and magnitude has been detected, and then causing the remaining one-phase circuit breaker to close.

100 ELECTRIC POWER SYSTEM

FIG. 1

CIRCUIT BREAKER

300 TRANSFORMER

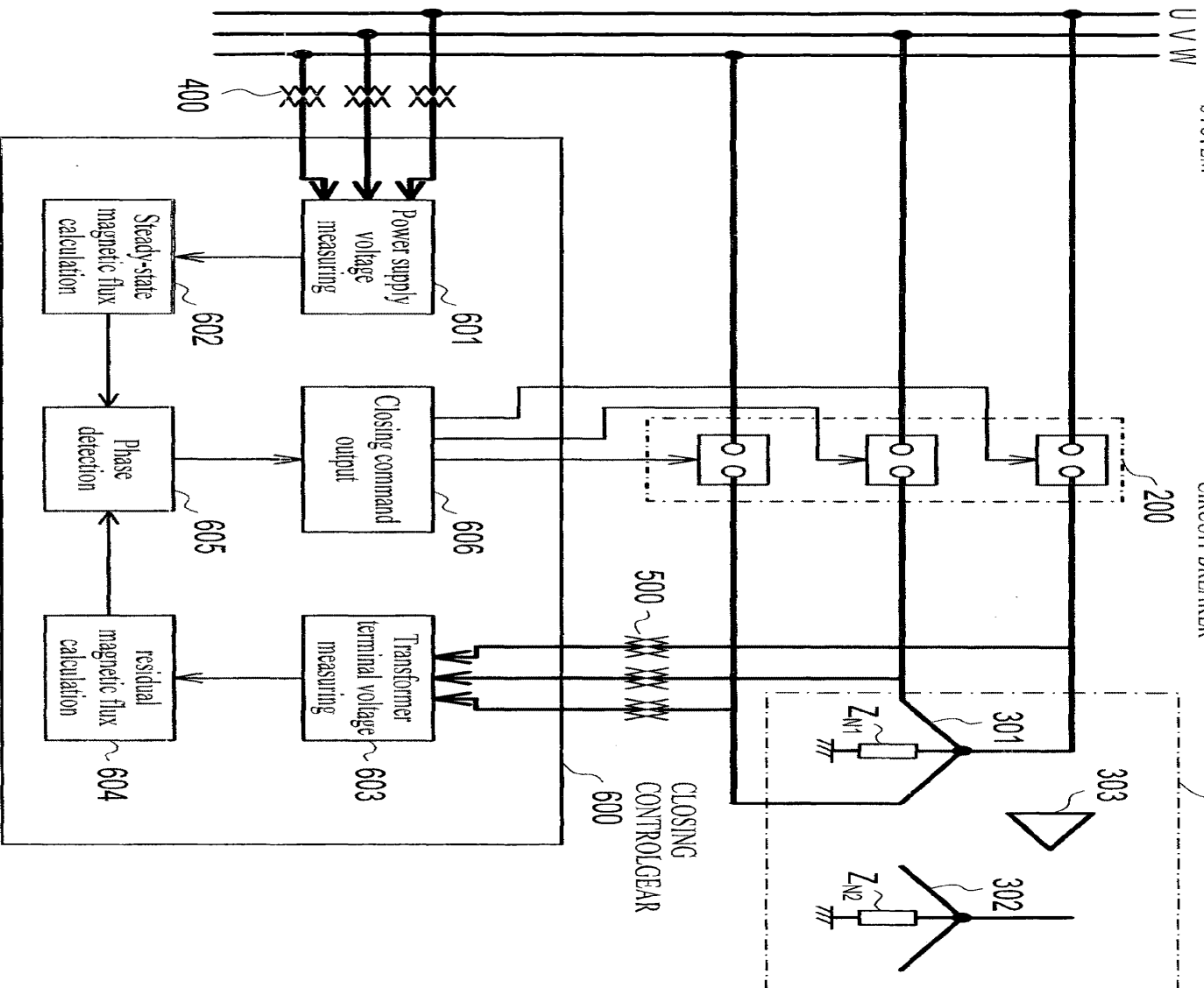

FIG. 2

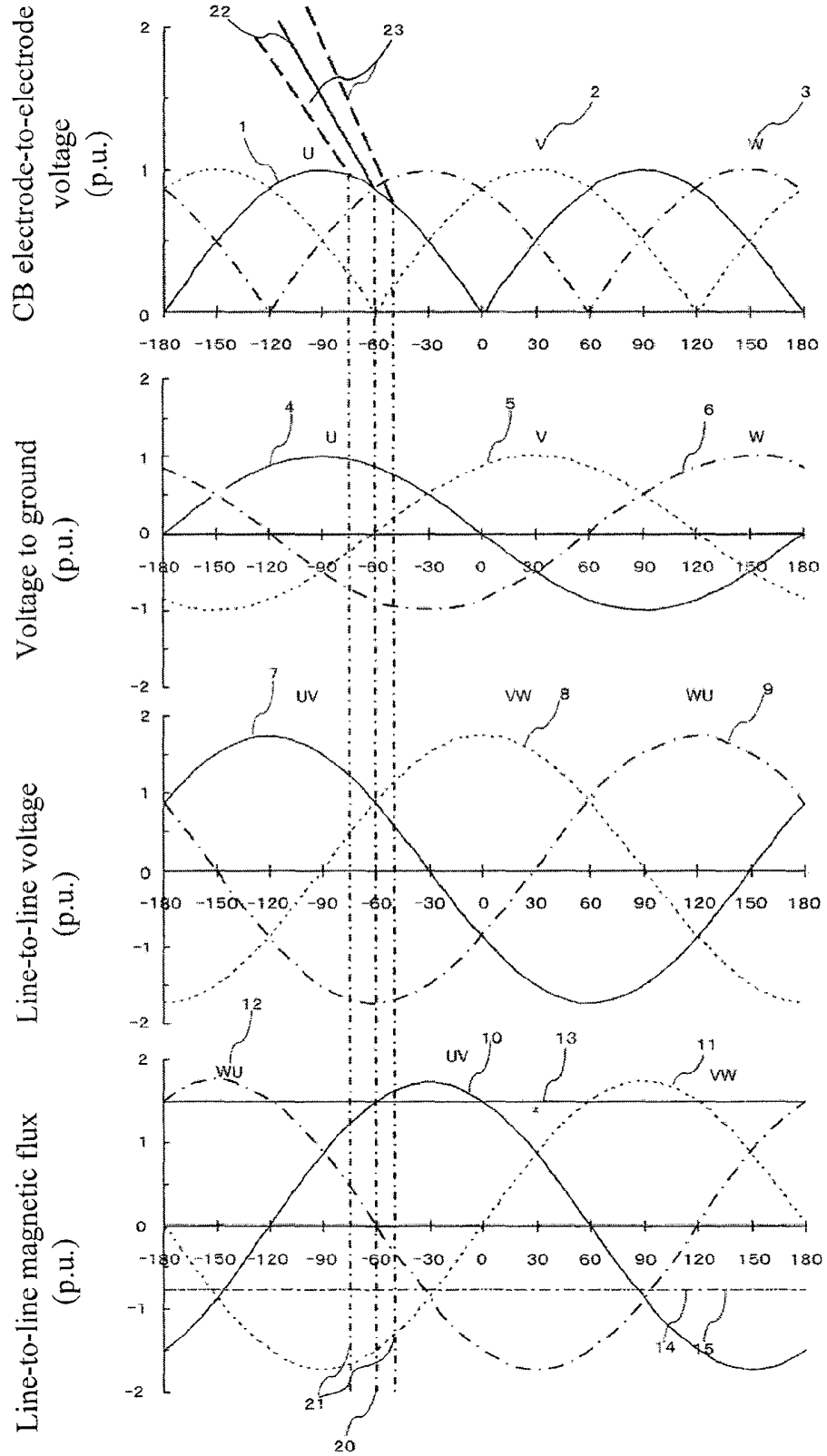
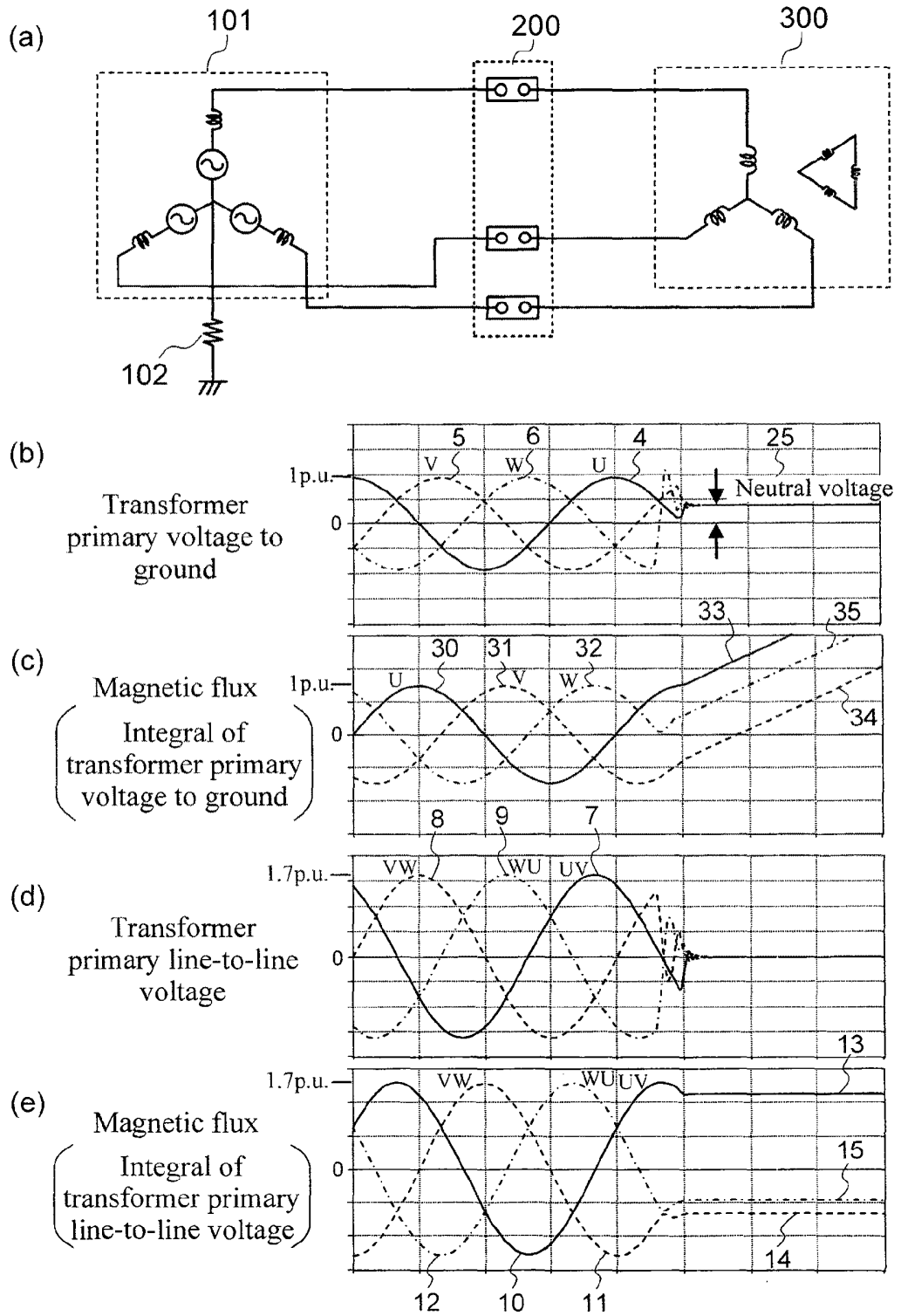

FIG. 3



Exciting current (A) Line-to-line magnetic flux (Wb) Line-to-line voltage (KV) Voltage to ground (KV)

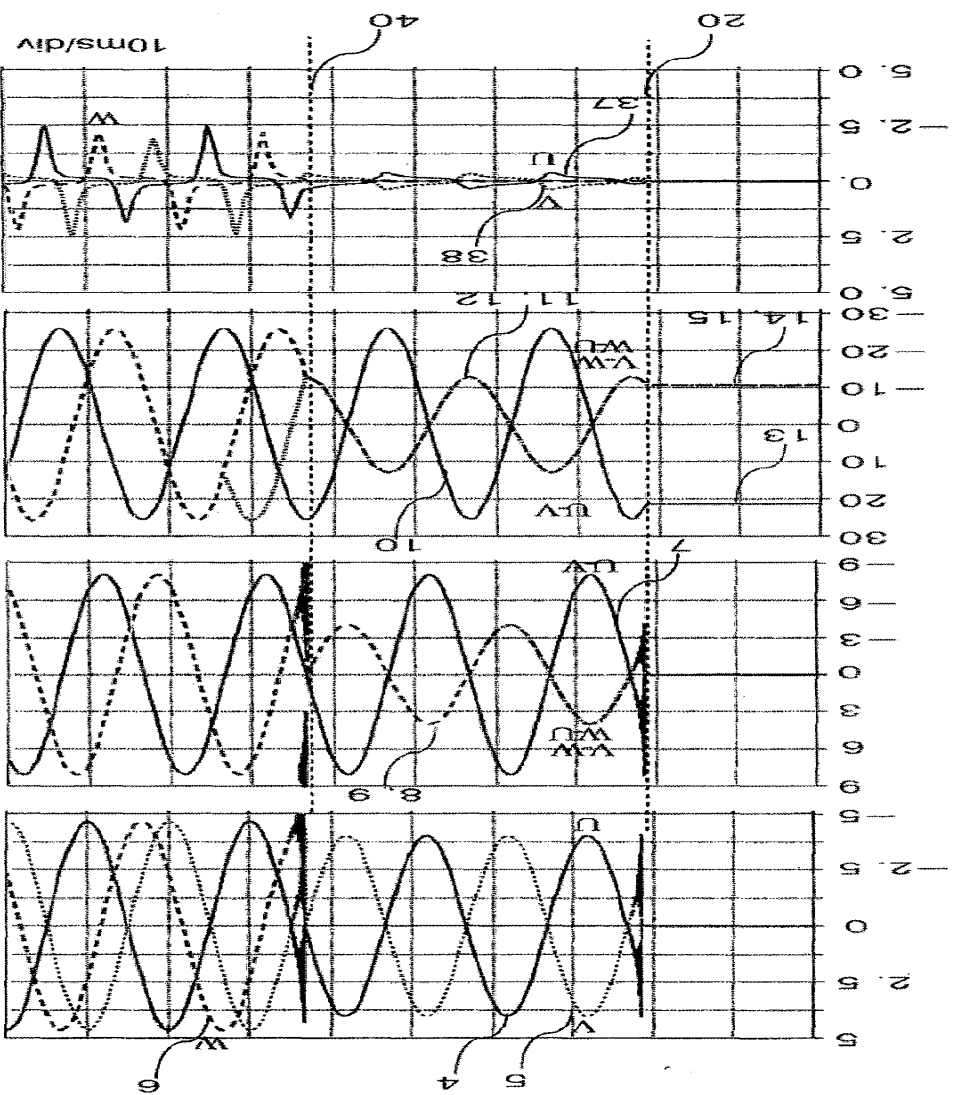

FIG. 4

FIG. 5

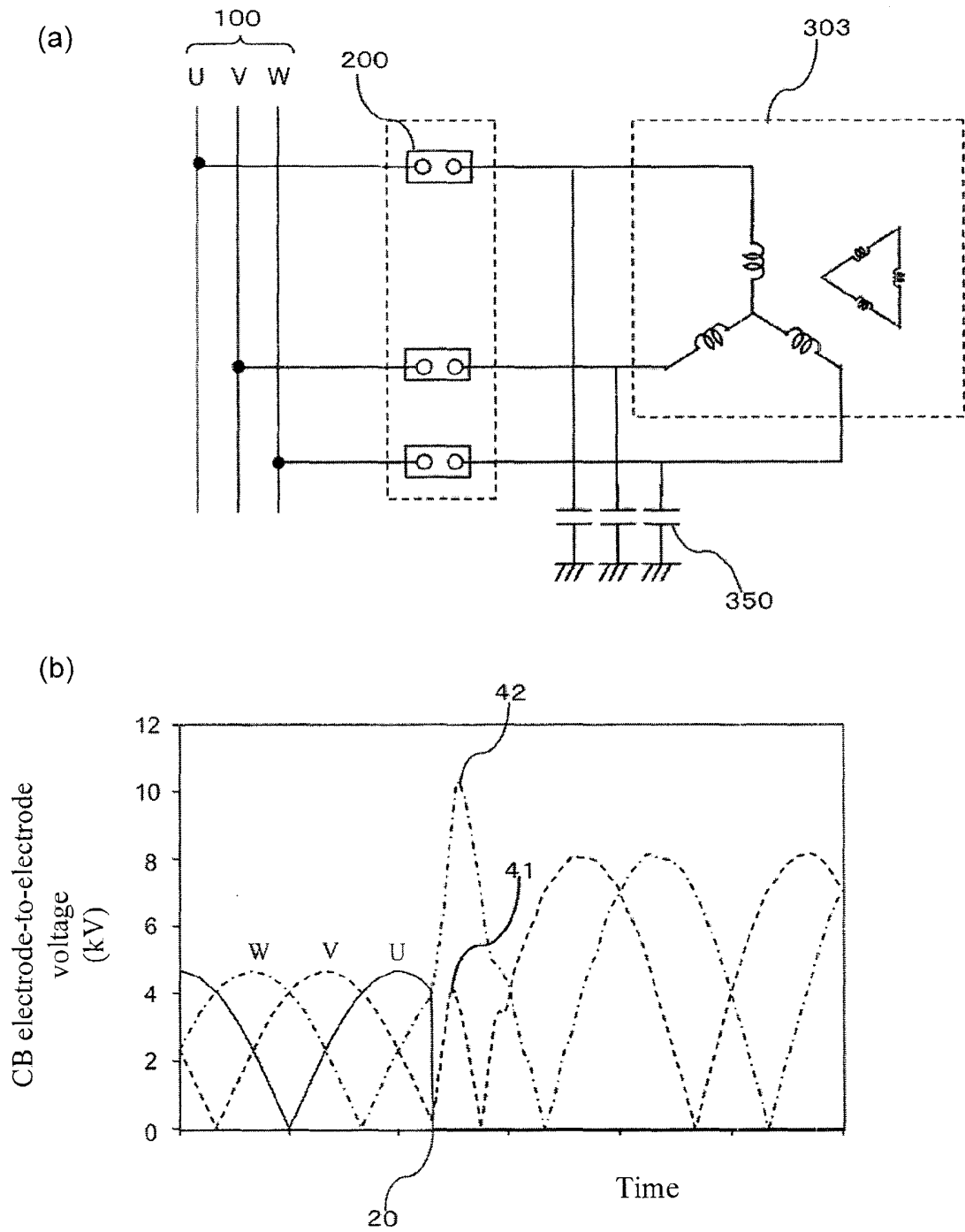

FIG. 6

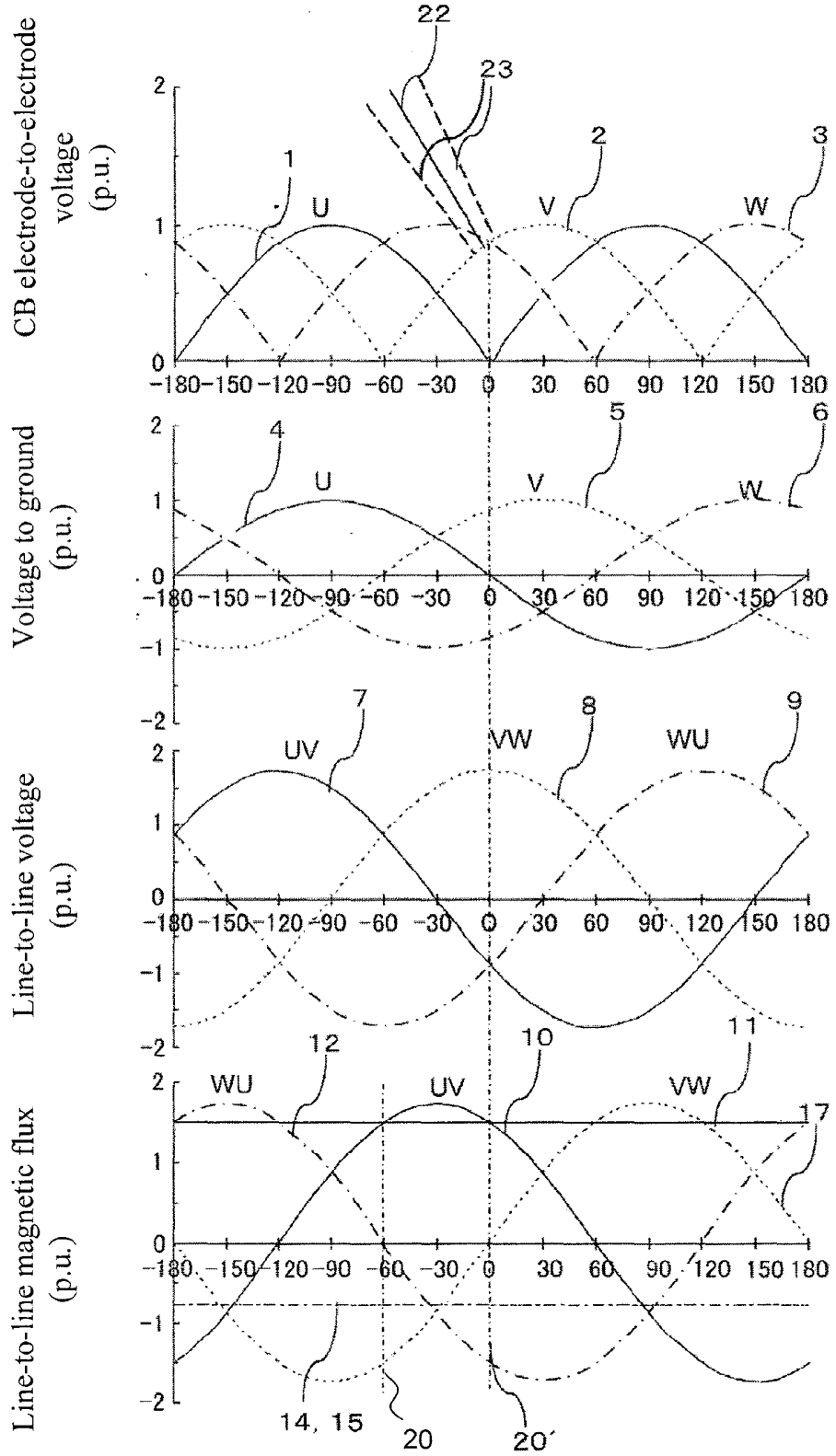

FIG. 7

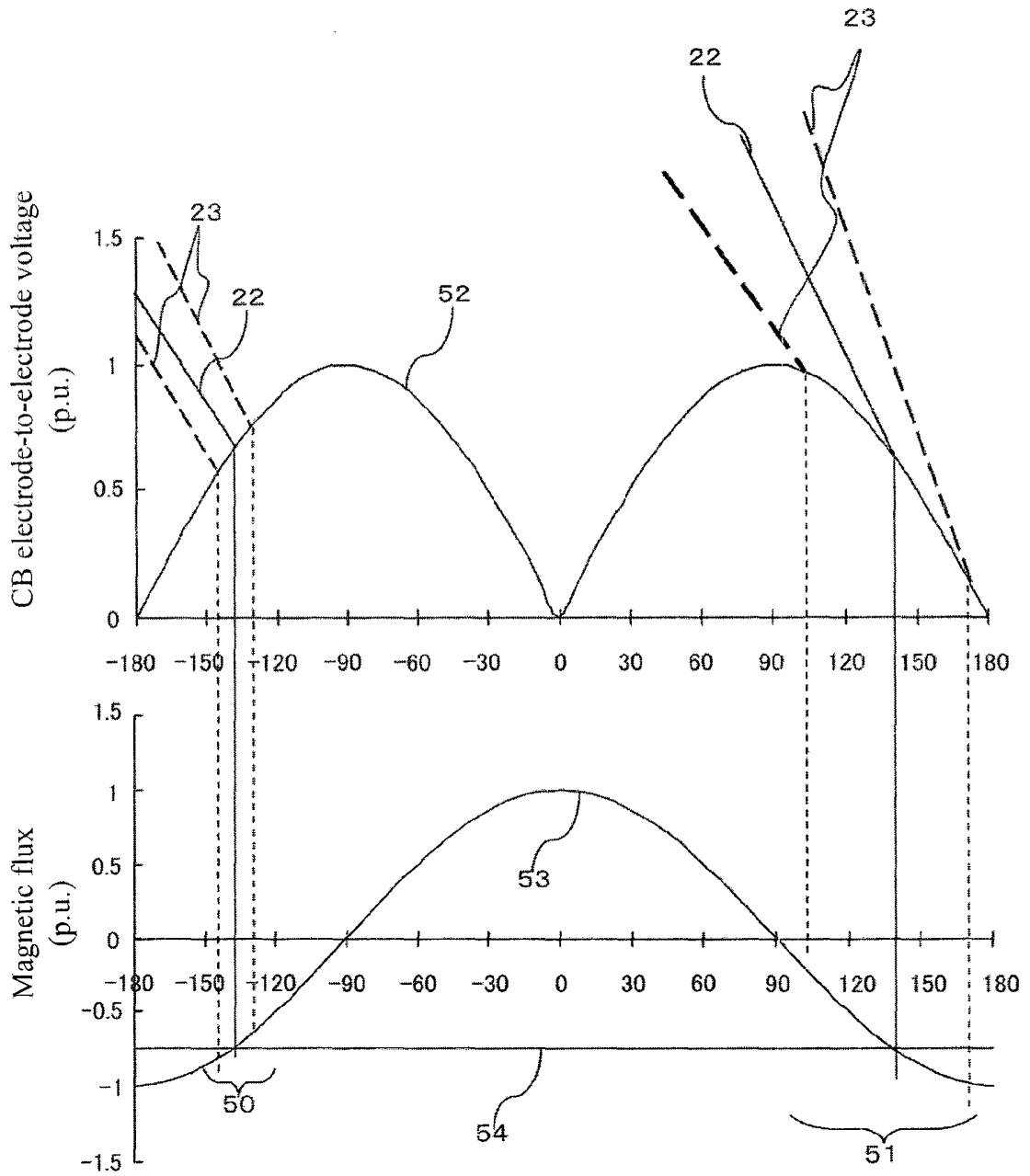
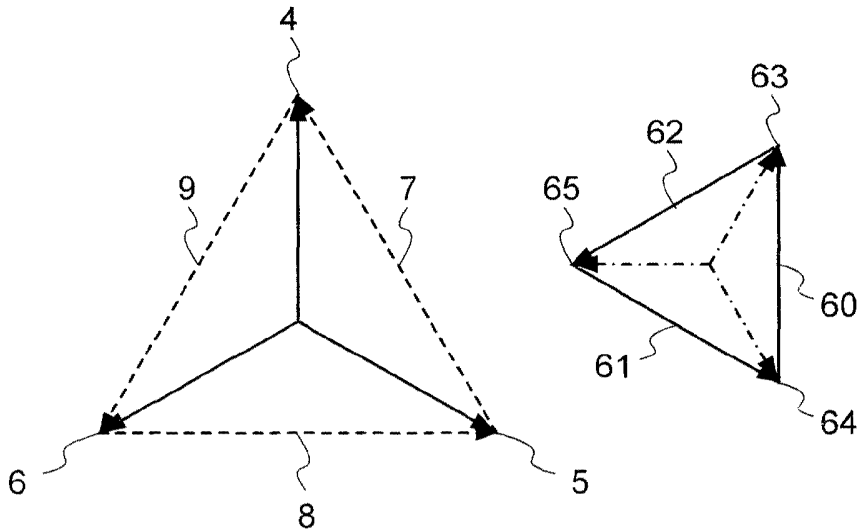
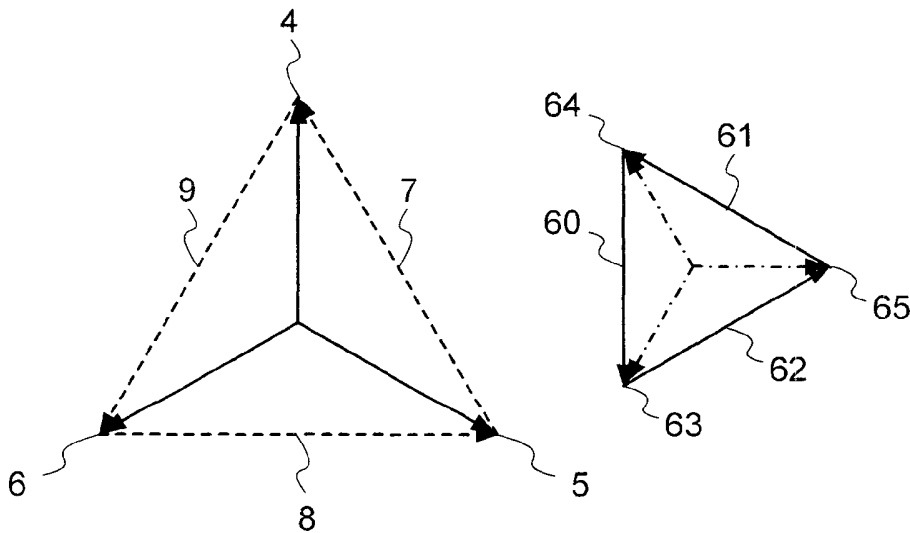

FIG. 8

(a) Phase sequence relation on Y side and Δ side is $+30^\circ$



(b) Phase sequence relation on Y side and Δ side is -30°



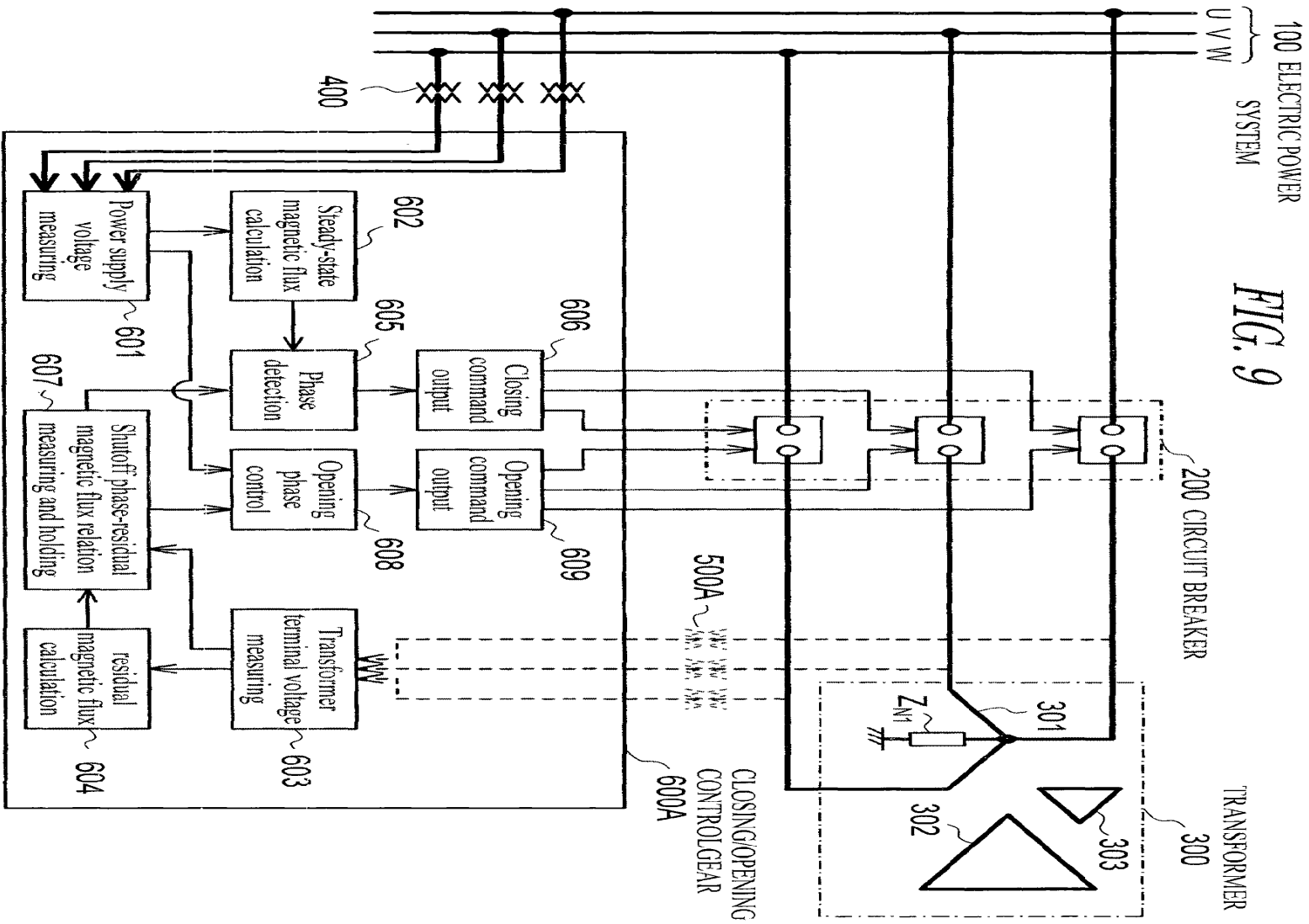
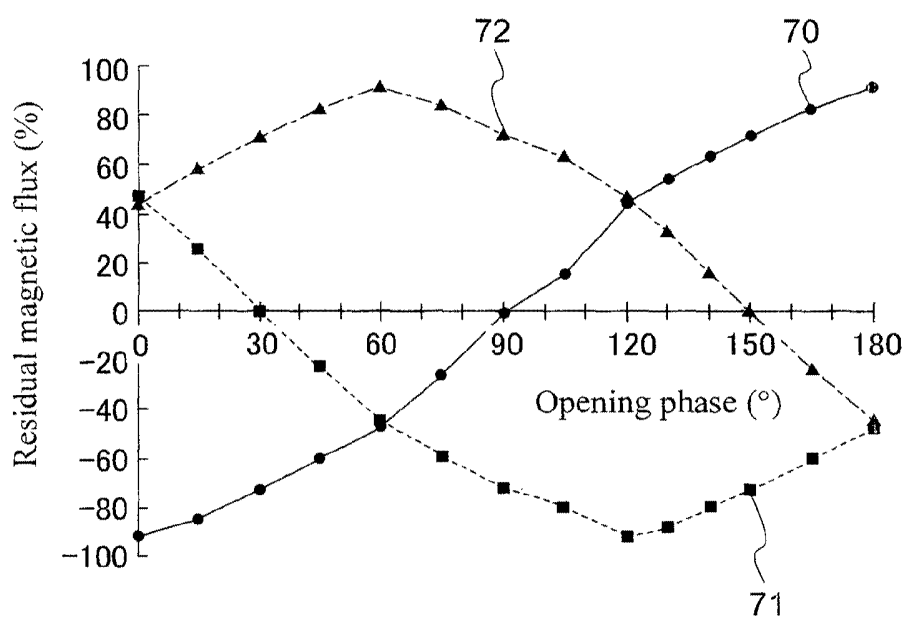

FIG. 9

FIG. 10

RESUMO

**"DISPOSITIVO PARA SUPRESSÃO DE CORRENTE DE IRRUPÇÃO DE
MAGNETIZAÇÃO PARA TRANSFORMADOR E MÉTODO DE CONTROLE DO
MESMO"**

5 To provide a magnetizing inrush current
suppression device for transformer and control method of
same, which accurately calculates the residual magnetic
flux when a transformer installed in a non-effectively
grounded system, is shut off by circuit breakers, and which
10 enables suppression of the magnetizing inrush current
occurring when three single-phase circuit breakers or phase
segregated operation-type circuit breakers are used for
simultaneously supplying power to three phases of the
transformer, without providing a circuit breaker with a
15 resistor or other equipment to enlarge the circuit breaker.
The device has steady-state magnetic flux calculation means
for calculating the line-to-line steady-state magnetic flux
of three-phase power supplies, residual magnetic flux
calculation means for calculating the primary line-to-line
20 residual magnetic flux of the transformer when the circuit
breakers shut off the transformer, phase detection means
for detecting a phase at which the polarity and magnitude
of the calculated steady-state magnetic flux and residual
magnetic flux coincide for each line-to-line. Closing
25 control means firstly causes only two-phase of the circuit
breakers, which are connected with the line-to-line, to
close at the detected phase, and then causes the remaining
one-phase circuit breaker to close.