

No. 849,904.

PATENTED APR. 9, 1907.

D. KOVÁCS.  
VISE.

APPLICATION FILED FEB. 6, 1907.

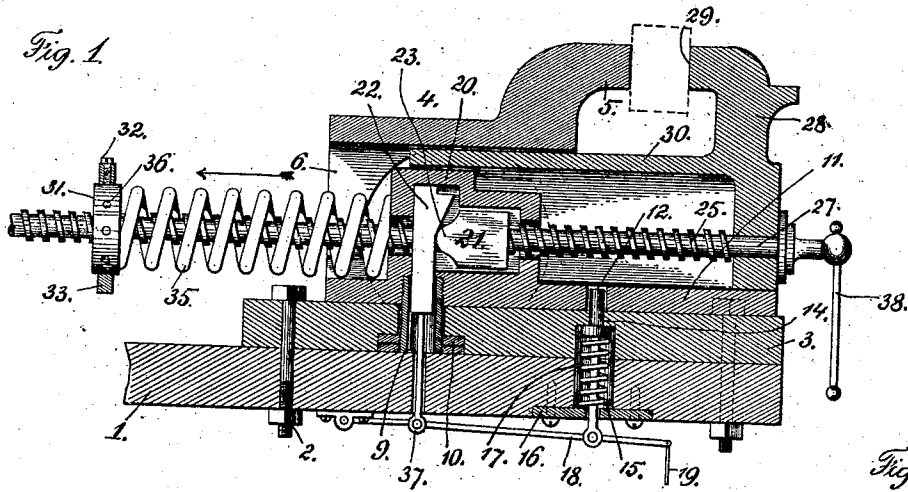

Fig. 3

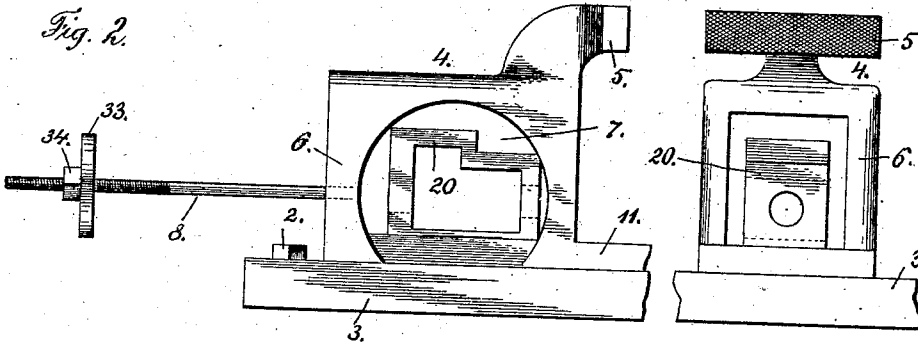

Fig. 2

Fig. 4

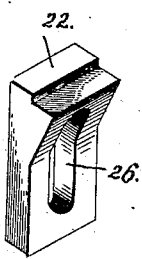

Fig. 5

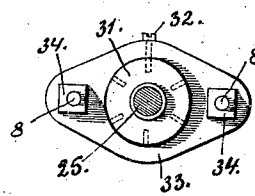
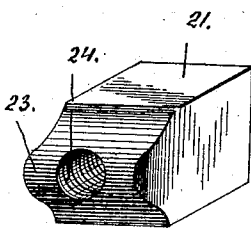

Fig. 6

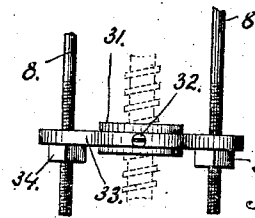

Fig. 7

WITNESSES:

*A. H. Ralsag*

*A. H. Butler*

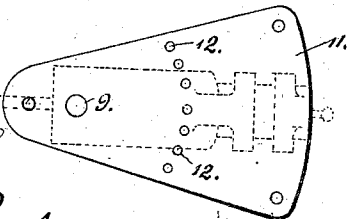

Fig. 8

*Dyónis Kovács.*

By  
*H. E. ...*

Attorneys

# UNITED STATES PATENT OFFICE.

DYÖNIS KOVÁCS, OF EAST PITTSBURG, PENNSYLVANIA.

## WISE.

No. 849,904.

Specification of Letters Patent.

Patented April 9, 1907.

Application filed February 8, 1907. Serial No. 356,359.

*To all whom it may concern:*

Be it known that I, DYÖNIS KOVÁCS, a subject of the King of Hungary, residing at East Pittsburg, in the county of Allegheny and State of Pennsylvania, have invented certain new and useful Improvements in Vises, of which the following is a specification, reference being had therein to the accompanying drawings.

This invention relates to vises; and the invention has for its primary object the provision of novel means for quickly clamping a piece of work between the gripping-jaws of the vise, thus dispensing with the troublesome operation of adjusting the widely-separated jaws of a vise to a small piece of work.

Another object of this invention is to provide a vise with means for easily and quickly releasing the piece of work held between the gripping-jaws of the vise.

A further object of this invention is to provide a vise with gripping-jaws that can be laterally adjusted to hold a piece of work at any desired angle.

With the above and other objects in view, which will more readily appear as the invention is better understood, the same consists in the novel construction, combination, and arrangement of parts to be hereinafter more fully described and then specifically pointed out in the appended claims.

Referring to the drawings forming part of this specification, like numerals of reference designate corresponding parts throughout the several views, in which—

Figure 1 is a longitudinal sectional view of a vise constructed in accordance with my invention. Fig. 2 is a side elevation of a portion of a vise, illustrating the pivoted gripping-jaw. Fig. 3 is a front elevation of the same. Fig. 4 is a perspective view of a wedge member used in connection with a vise. Fig. 5 is a similar view of a block. Fig. 6 is a cross-sectional view of a threaded rod, illustrating an adjustable collar carried thereby. Fig. 7 is a plan of the collar. Fig. 8 is a bottom plan of the pivoted jaw.

In the accompanying drawings, 1 designates a bench or suitable support upon which is bolted or otherwise secured, as at 2, a plate 3, carrying a housing 4, having a serrated gripping-jaw 5. The side walls 6 of the housing 4 are provided with oppositely-disposed openings 7 and with rearwardly-extending threaded guide-rods 8. The housing 4 is revolvably mounted upon the plate 3

by a tubular stem 9, secured in the plate 3 by nuts 10, said tubular stem and nuts revolving with the housing 4. To hold the housing in a fixed position, the base 11 of said housing is provided with a plurality of openings 12, said openings being arranged on an arc with respect to the tubular stem 9. Adapted to engage in said openings is a plunger 14, which is held within the plate 3 and the bench 1 by a coiled spring 15, said spring bearing upon the closure-plate 16 of the recess 17. The plunger 14 connects with a pivoted rod 18, said rod being provided with a depending cable or rod 19, adapted to be connected to a tread-plate (not shown) which an operator or workman can press to remove the plunger 14 from one of the openings 12 and shift the housing 4 at any desired angle with relation to the plate 3.

Upon the base 11 of the housing 4 is formed a cage 20, in which is mounted a block 21 and a wedge member 22, said member being adapted to engage the rounded end 23 of a block 21. The block 21 is provided with a threaded opening 24, in which is mounted for rotation a screw 25, said screw passing through a slot 26, formed in the wedge member 22, through the cage 20, and having its forward end loosely mounted, as at 27, in a movable jaw 28. The movable jaw besides having a serrated gripping-surface 29 is formed with a rearwardly-extending casing 30, adapted to telescope the rod 25 and the cage 20 of the housing 4.

The outer end of the threaded rod 25 is provided with an adjustable collar 31, said collar being normally fixed by a screw 32 in the cross-head 33, said head being retained upon the threaded guide-rods 8 by nuts 34. Surrounding the threaded rod 25, between the adjustable collar 31 and the rear face of the cage 20, is a coiled spring 35, said spring being secured to the head 33 and to the rear face of the cage 20. The adjustable collar is provided with a plurality of openings 36, whereby it may be adjusted within the cross-head 33 and secured in its adjustable position by the screw 32.

The lower edge of the wedge member 22 is connected to the pivoted rod 18 by a link 37. Upon the forward end of the threaded rod 25 is loosely mounted a crank-arm 38 for manually rotating the threaded rod 25.

In operation the block 21 normally engages the wedge member 22 and the position of the threaded rod 25 within said block gov-

erning the distance between the gripping-jaw 5 and the gripping-surface 29 of the movable jaw 28. Assuming that a piece of work is to be placed between the jaws, the pivoted rod 18 is pulled downwardly, which through the medium of the link 37 causes the wedge member 22 to press the block 21 forward, carrying with it the threaded rod 25 and the movable jaw 28. In case the gripping-jaws are not sufficiently separated to engage a piece of work the crank-arm 38 can be rotated to carry the movable jaw 28 forward, this being accomplished by the block 21 remaining stationary while the threaded rod 25 and the jaw 28 are moved.

To increase the tension of the spring 35 at any desired time, the screw 32 is removed from the collar 31 and said collar adjusted upon the threaded rod 25, at which time the cross-head is moved and again secured to the adjustable collar 31. The nuts 34 are then rotated to engage the cross-head.

It is thought from the foregoing description, taken in connection with the drawings, that the construction and operation will be apparent to those skilled in the art of manipulating a vise, and I desire it to be understood that such changes in the size, proportion, and minor details of construction as are permissible by the appended claims may be resorted to without departing from the spirit and scope of the invention.

What I claim, and desire to secure by Letters Patent, is—

1. In a vise, the combination with a bench, of a plate carried thereby, a housing revolvably mounted upon said plate and having a gripping-jaw, a cage formed within said housing, a movable jaw slidably mounted in said housing over said cage, a block mounted in said cage, a wedge-shaped member mounted in said cage and engaging said block, a threaded rod revolvably carried by said movable jaw, and passing through said block and said member, an adjustable collar carried by the outer end of said rod, a spring surrounding said rod between said collar and said cage, a spring-held plunger mounted in said bench and plate for holding said revolvable jaw in a fixed position, means to simultaneously lower said plunger and said wedge-shaped member, and means to lock said adjustable collar in a fixed position.

2. In a vise, the combination with a suitable support, of a housing revolvably mount-

ed upon said support and having a gripping-jaw, a cage formed within said housing, a movable jaw mounted over said cage, a block carried within said cage, a wedge-shaped member adapted to engage said block, a revoluble screw carried by said movable jaw and passing through said cage, block and wedge-shaped member, an adjustable collar carried by said screw, a spring interposed between said collar and said cage, means to hold said collar in a fixed position, means to hold said revolvable jaw in a fixed position, means to move said wedge-shaped member.

3. In a vise, the combination with a suitable support, of a housing pivotally mounted thereon, and having a gripping-jaw, a cage carried by said housing, a movable jaw slidably mounted in said housing, a threaded rod carried by said movable jaw and passing through said cage, an adjustable collar carried by said rod, a spring interposed between said collar and said cage, means to hold said collar in a fixed position, means located within said cage for temporarily moving said movable jaw, means carried by said support for holding said revoluble jaw in a fixed position, and means to simultaneously actuate the last two means.

4. In a vise, the combination with a suitable support, of a revoluble housing having a gripping-jaw, a movable jaw slidably mounted in said housing, a block carried within said housing, a revoluble threaded rod carried by said movable jaw and passing through said block, an adjustable collar mounted upon said rod, means for temporarily moving said movable jaw, means engaging said collar for returning said movable jaw to its normal position, and means carried by said support for locking said movable jaw in a fixed position.

5. In a vise, the combination with a suitable support, a housing carried thereby and having a gripping-jaw, a wedge-shaped member mounted in said housing, a spring-held block engaging said wedge-shaped member, a movable jaw, means to move said wedge-shaped member, means to adjust said movable jaw, and means to adjust said housing.

In testimony whereof I affix my signature in the presence of two witnesses.

DYÖNIS KOVÁCS.

Witnesses:

A. H. RABSOIG,  
MAX H. SROLOVITZ.