

(No Model.)

J. W. NYSTROM.
STEAM ENGINE.

No. 272,306.

Patented Feb. 13, 1883.

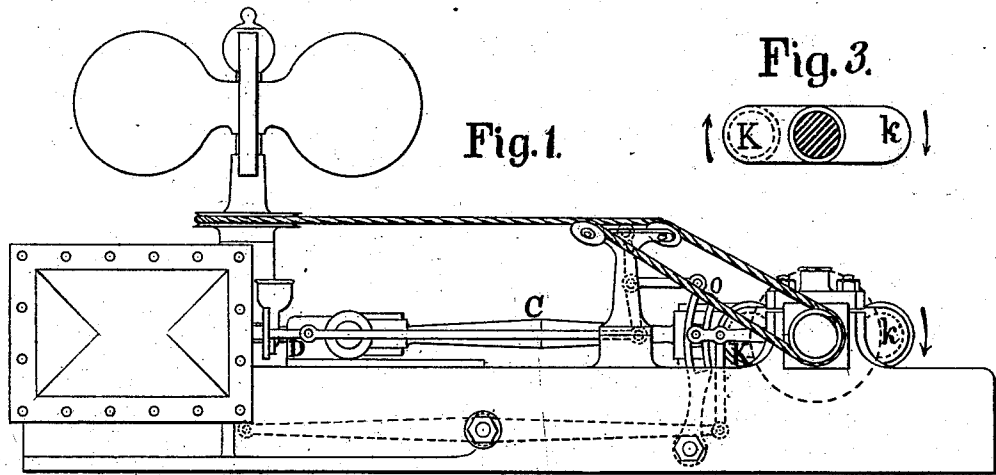

Fig. 1.

Fig. 3.

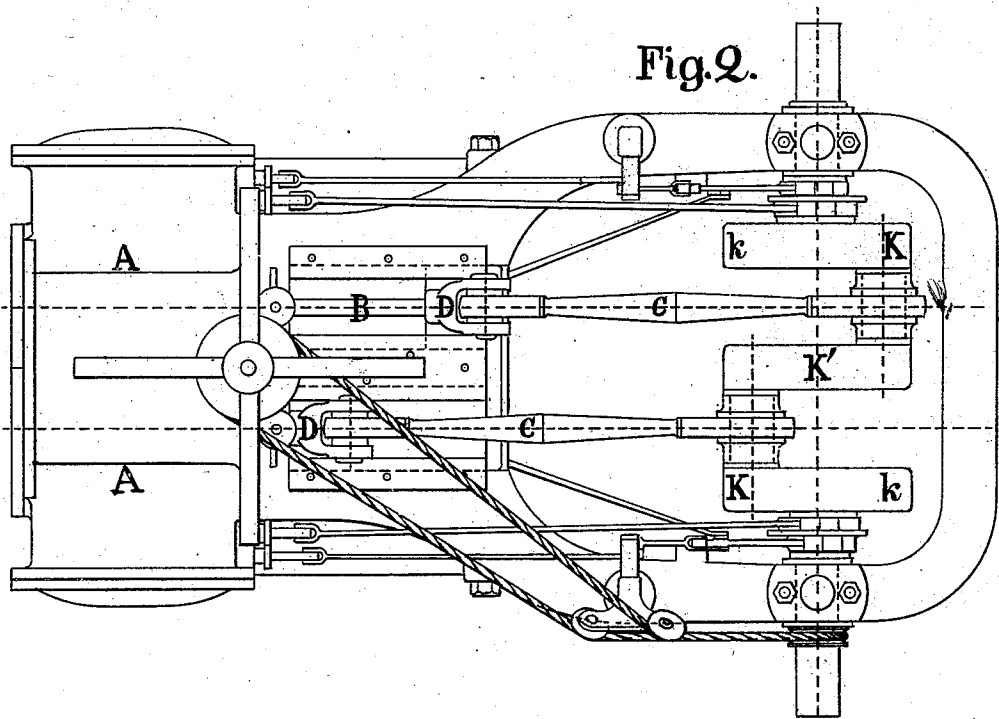

Fig. 2.

Witnesses.

W. H. Wood
R. W. Johnson

Inventor
John W. Nystrom

UNITED STATES PATENT OFFICE.

JOHN W. NYSTROM, OF PHILADELPHIA, PENNSYLVANIA.

STEAM-ENGINE.

SPECIFICATION forming part of Letters Patent No. 272,306, dated February 13, 1883.

Application filed September 19, 1882. (No model.)

To all whom it may concern:

Be it known that I, JOHN W. NYSTROM, of the city and county of Philadelphia, in the State of Pennsylvania, have invented certain new and useful Improvements in Steam-Engines, by which the moving parts are balanced for gravity, centrifugal force, and gyration, which enables the engine to run steady at a very high speed without noise or shaking.

The following specification, with the accompanying drawings, is a full explanation of my invention.

This engine is invented and designed for the purpose of driving machinery direct at a very high speed, as required for electro-dynamo machines, fans, centrifugal pumps, hoisting-machines, rolling-mills, screw-propellers, and in other cases where belting and gearing are objectionable for increasing speed. The ordinary steam-engine, when run at a high speed, is generally found to make objectionable noise by the unbalanced moving parts shaking the whole surrounding system to such an extent as to seriously interfere with the proper execution of the work. In my improved engine all the moving parts are balanced, as will be understood by the accompanying drawings with three different illustrations of my invention.

Figure 1 represents a side elevation of a horizontal stationary engine. Fig. 2 is a plan of the engine, showing how the moving parts are balanced. Fig. 3 shows the counterpoise for balancing the gyration of the cranks.

The engine consists of two steam-cylinders, A A, Fig. 2, placed side by side, the pistons of which are connected direct by piston-rods B and connecting-rods C, to balance opposite cranks, K k. When in motion the piston, piston-rod, and connecting-rod of each engine move in opposite directions, and thus the momentums of the two reciprocating systems balance each other. The motive power is applied direct from the piston to the crank—that is, the piston-rod and connecting-rod of each engine are in the same straight line when the cranks are on the centers. When the connecting-rod is placed at one side of the direction of the center line of the piston-rod, then the motive power is not working direct, but side-wise. The two steam-cylinders are cast in one piece, making only one thickness of metal be-

tween them, and, as represented on the drawings, the bed-plate is cast in the same piece with the cylinders, which makes the combination a rigid system. The two cranks K K are made in one piece, opposite to one another, and balanced for gravity, centrifugal force, and gyration. A revolving body balanced for gravity may not be balanced for centrifugal force and gyration, and it may be balanced for both gravity and centrifugal force, but not for gyration, which latter is most generally the case. When a revolving body of high speed is not balanced for gyration, the slightest change of speed will make the system shake or vibrate. In order to overcome this difficulty, I make a counterpoise, k, on each crank of equal form to that of the part K, Figs. 2 and 3, which balances the revolving crank for gravity, centrifugal force, and gyration. Without the counterpoise k the opposite cranks would be balanced only for gravity, but not for centrifugal force and gyration, which two latter forces would work and shake the system when running at a high speed. When the counterpoise k is of a different shape from that of the part K, then the system may be balanced for gravity and centrifugal force, but not for gyration, as is generally the case in propeller-engines, where the counterpoise is made of a different shape from that of the crank. The center part, K', Fig. 2, of the cranks is of equal form to that of K and k, and is therefore balanced. The two crank-pins, with their collars, balance one another. The reciprocating systems—that is, the steam-piston, piston-rod B, cross-head D, and connecting-rod C of each engine—move in opposite directions, and therefore balance one another very nearly, but not perfectly so on account of the connecting-rods being of definite lengths; but when the length of the connecting-rod is three times the length of the stroke, or more, the difference is so small as to be inappreciable in practice. This objection can, however, be overcome by making the cranks to work in slot-motions, which is readily understood by mechanical engineers.

Of the two engines, either one of them can be used with steam, while the other can run empty and only serve for balancing the reciprocating systems; or, if the weight of metal in the piston and piston-rod of the empty engine be placed in its cross-head D, it would

also balance the reciprocating systems, but would not work so well in the journals as with steam in both cylinders.

5 Opposite cranks are described in my treatise on screw-propellers, published in 1852, and cranks balanced for gravity have been used, and are not new; but these cranks have not been balanced for centrifugal force and gyration, nor are opposite cranks as used in propeller-
10 engines constructed as herein described as my invention, but have journals or eccentrics between the cranks. My invention can be applied equally well to horizontal, inclined, or vertical engines.

I claim—

15 A steam-engine with cylinders side by side working direct upon opposite cranks, which are balanced for gravity, centrifugal force, and gyration, without journals or eccentrics between the cranks, substantially as and for the
20 purpose described.

JOHN W. NYSTROM.

Witnesses:

T. ELLWOOD POTTS,

R. A. JOHNSON.