

(19)
(12)

(KR)
(A)

(51) 。 Int. Cl. ⁷
H02K 3/12
H02K 15/04

(11)
(43)

2002 - 0005955
2002 01 18

(21) 10 - 2001 - 0021141
(22) 2001 04 19

(30) 2000 - 208766 2000 07 10 (JP)

(71) 가 가
,
2 2 3

(72) 가
2 2-3 가 가
2 2-3 가 가
가
2 2-3 가 가
2 2-3 가 가
2 2-3 가 가
2 2-3 가 가
가 가
2 2-3 가 가

(74)

:

(54)

가 , 가

가

4

1

2

3 1

4 2

5

6 5

7

8 7

9

10

11 10

12

13 12

14 13

15 14

16 12

17 16 .
18 .
19 .
20 .
21 ,
22 21 .
23 22 .
24 23 , .
25 24 .
26 .
27 .
28 .
29 28 A - A .
30 .
31 .
< >
1 ,3, 13, 18 ,
7, 14, 19 ,19 ,
21 ,22 ,
9 ,55~59 ,
58 ,85 ,
86 .

30 (101) (102) 가
 (101) (103) .

가 (101) 30 ,
 , 가 .
 1 ,

(40) , 31 (41) 가 (42) 1 2 (43) (46)
 , (44) (45) 가 가
 , 가 가 가
 가 가 가 , 가
 가 가 가 , 가

(1) , ,

(2) 360 .

(3) 360 가 .

1.

1 (1) (1) (1)
 (2) (1) (3)
 (1) 가 (1) (3) 2 (1)

(3) 3 (4) (5)
 , 4 (6)
 (7) (8) (7) 1 (6) (4)
 (5) (7) (9)

(7) , (1)
 (7) , 가 (6) (6)
 (6) 가 (6) / /
 (6) 가 (6) 가, / (6)
 가 () (6)

(7) 30
 , 가 / 가
 , 가 가 , 가 가
 가 가 (7)가

5 , 2 (1) (3)
 (3) (10) 가 , (10)
 6 (11) (9) (12) (7)가 (3) 4

2.

7 , 360 (13)
 (15) (16) 가 (13) 9
 1 3 , 8 ()
 (14)가

3.

10 (18) (1) 360
 () (19) 360 (18) , 9
 (19) (19)

가 . (18) 1 3 (19)가 . 11
 ()

4.

12 , 1 3 () ,
 (20) . (20)
 (21) , (21) ,
 (22) . (20)
 . 12
 $P_n \cdot P_{n+1}$,
 $P_n > P_{n+1}$, 가 . (21)
 가 n (n+1) (21)

7 (蛇行) (20) 9
 (13) , 10 (18) 13 (24)
 (24) 2 (25) (26)
 (27) (29) (30) (13) (27)
 (29) (31) (24)
 , 14 (33) (14)
 (33) 15 (34) 14
 (33) () , 12
 (20)

16 17 12 (20)
 (36) . (36) (37) U
 (38) , (38) (39) (40) (40) (4)
 0) (38) U (41) , (41)
 (40) (39) (42) (43)

(18) (32) , 8 (13) 10
 (44) (45) (36) (40) (39) 16

(43) (40) , (40) (39) (18) (43) (40)
 (41) (38) , (41) (38) (20)가 . 1
 2

5.

18 ,

3 (46) (18) 3 (46) (47), (48) (49) (22)가 (50)
 (47),(48) (49) (21) (50) (49)
 (가) (47),(48) (49)
 , 가, (47), (48) (49) (50)
 (46) (50)

18 (46) 12
 (20)
 6.

19 (51) , 18 (50) 3 3
 (52),(53) (54) (55),(56) (57) (58) (51)
 가 A ,
 B .

가 (55),(56) (57) (58) ()
 , 가

7.

20 (60)가 20 C (61),(62) (63)
 20 D 가 E
 (61),(62) (63) 가 (60)
 가 가 가
 가 1 가

8.

21 25 ()
 , 21 (1)
 (65) (66)

(65) 가 (1) (65) 22 (67) 23 (68)
 (67) (66) 7 (67) (65)
 24 (67) (65)

가 가 .

(2) 360 , 1
가

1

(3) 360 가 ,

(57)

1.

2.

1 , 360

3.

1 , 360 가

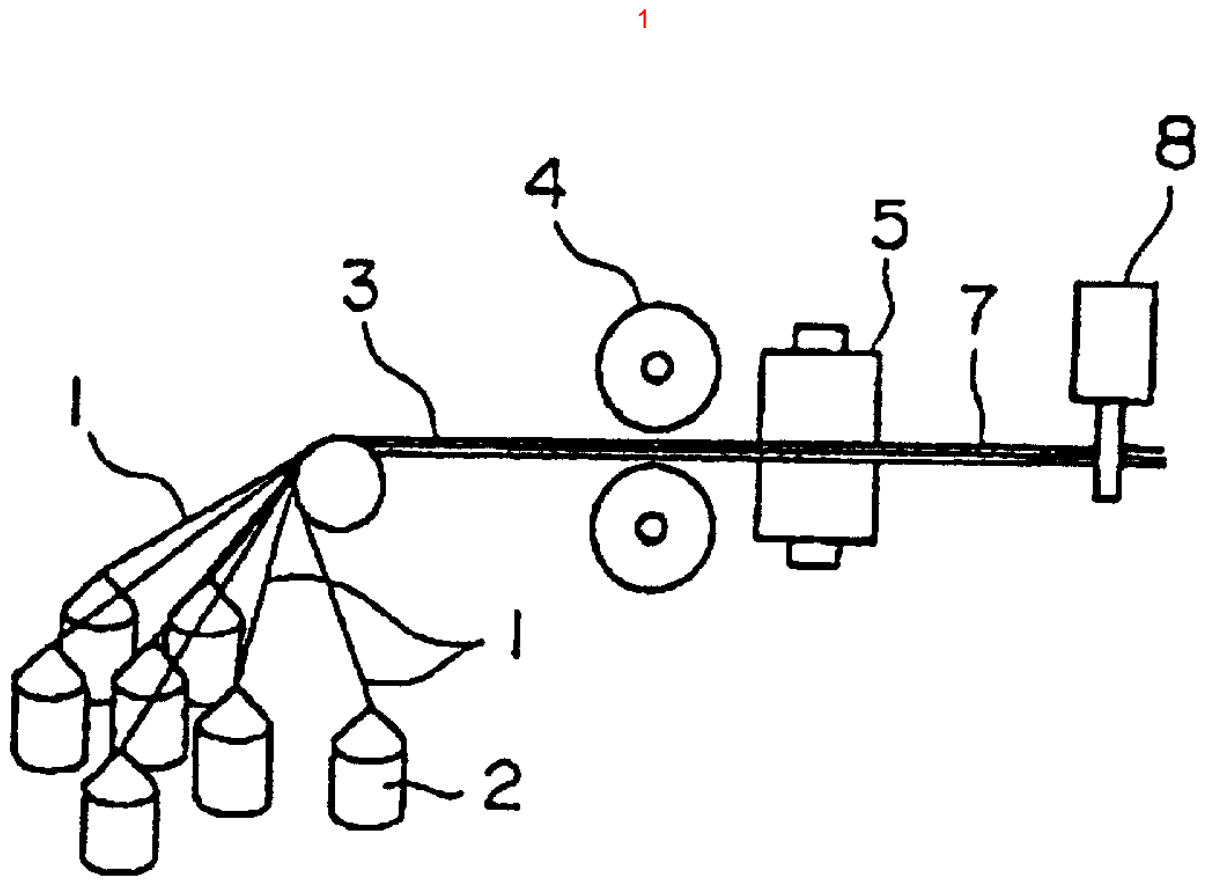

2

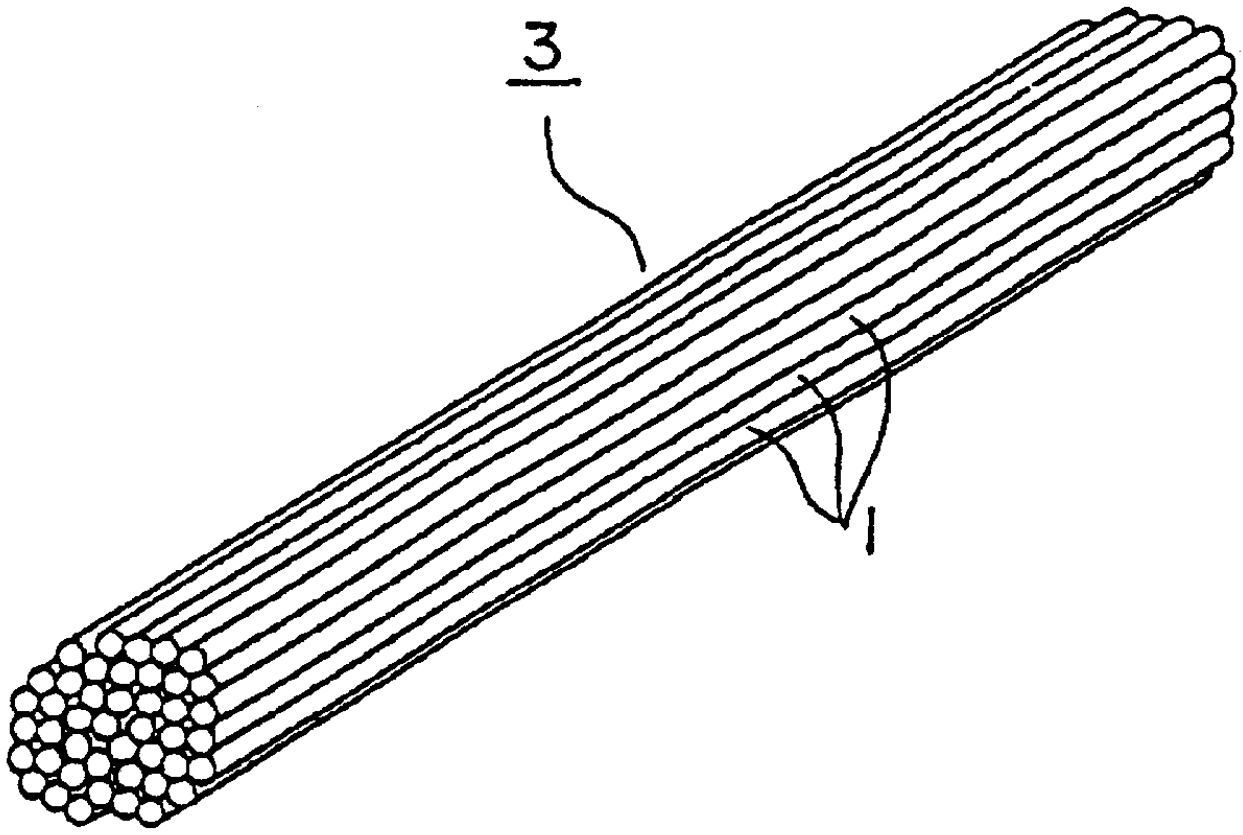

3

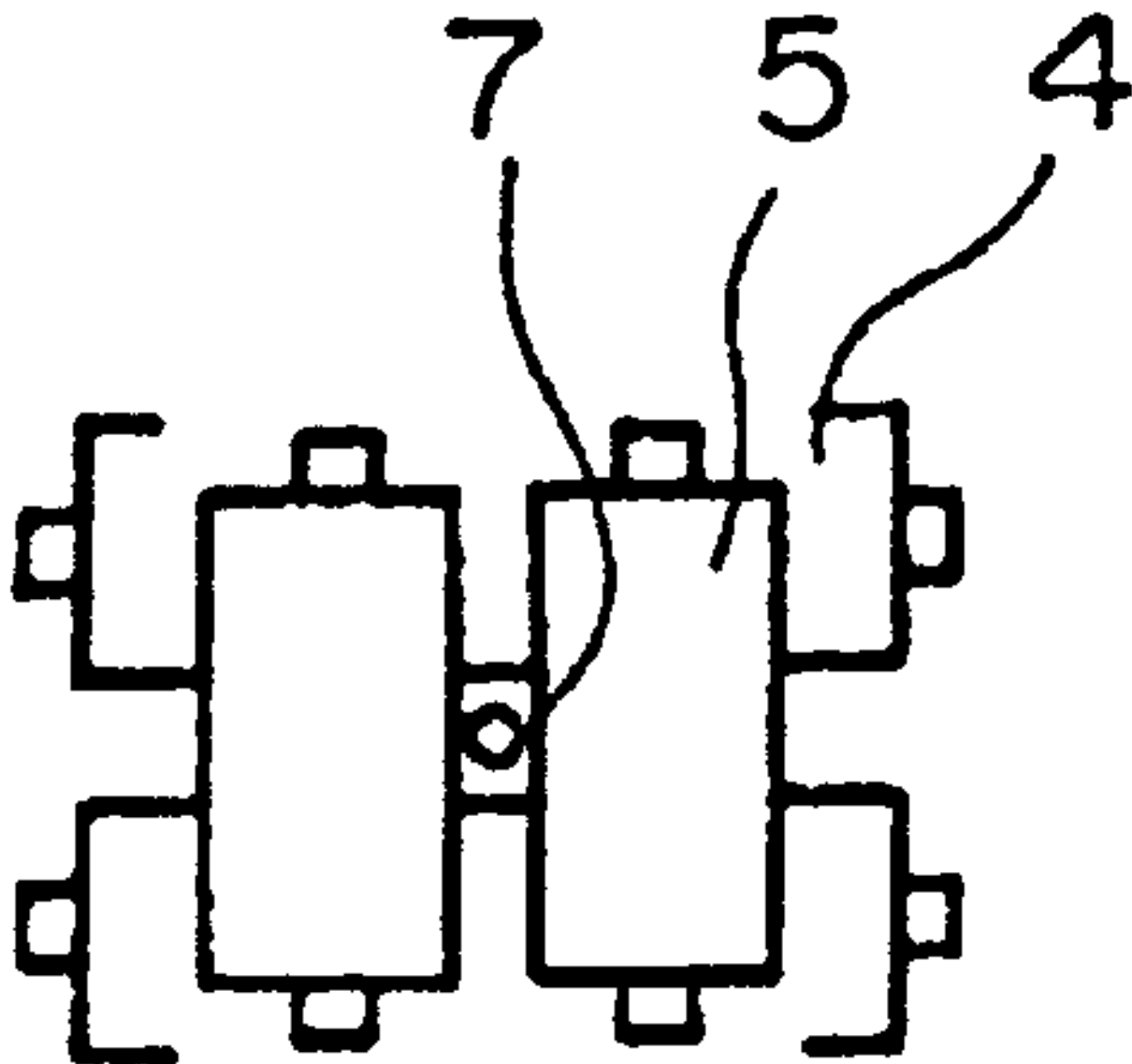

4

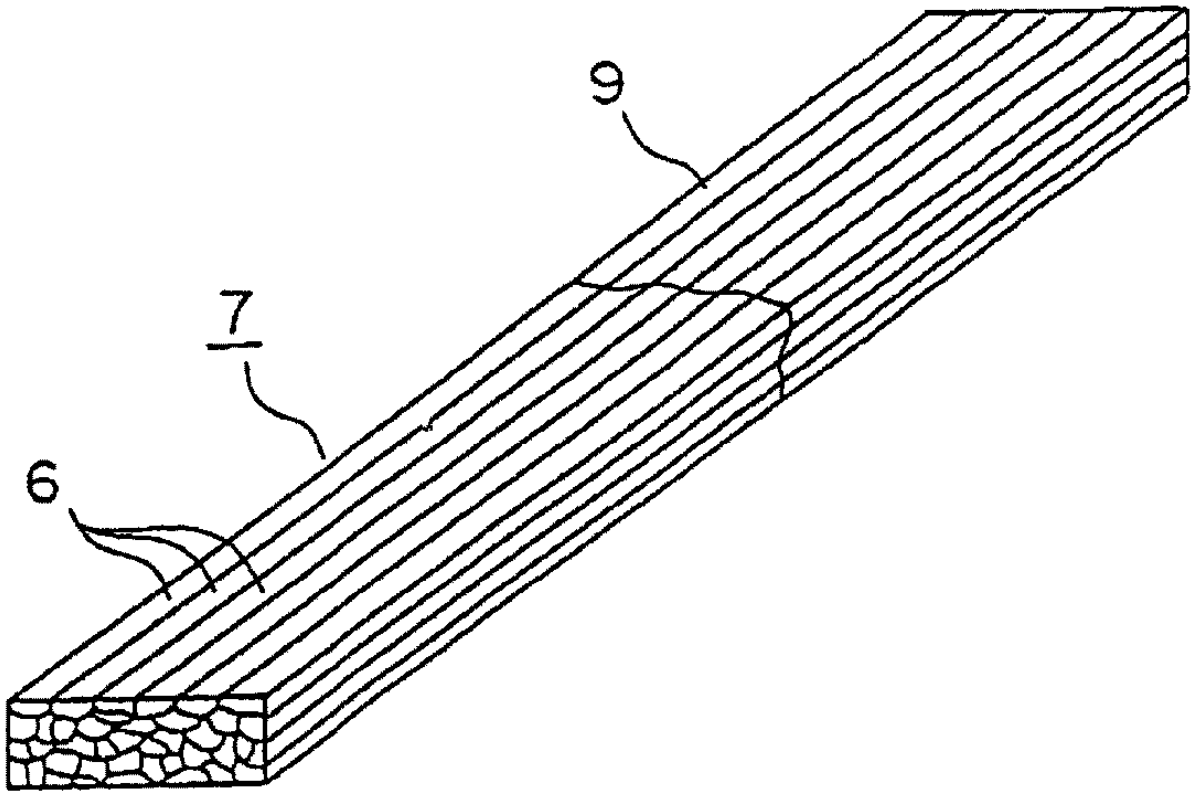

5

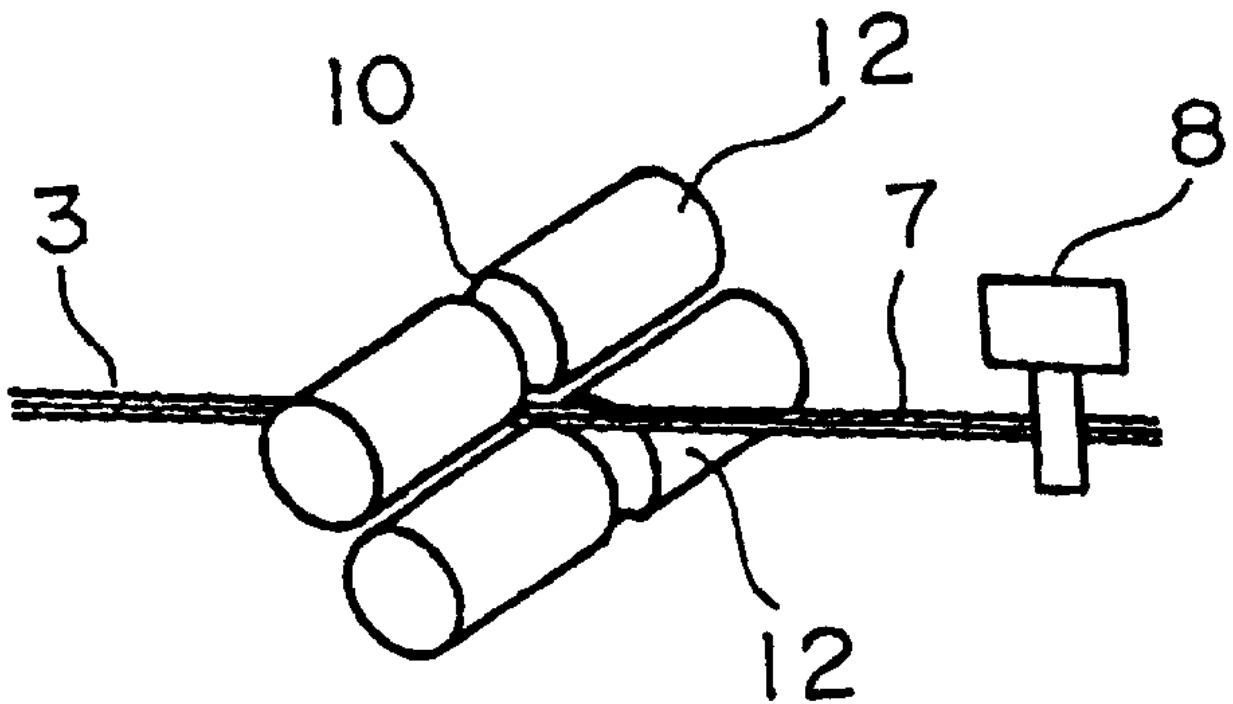

6

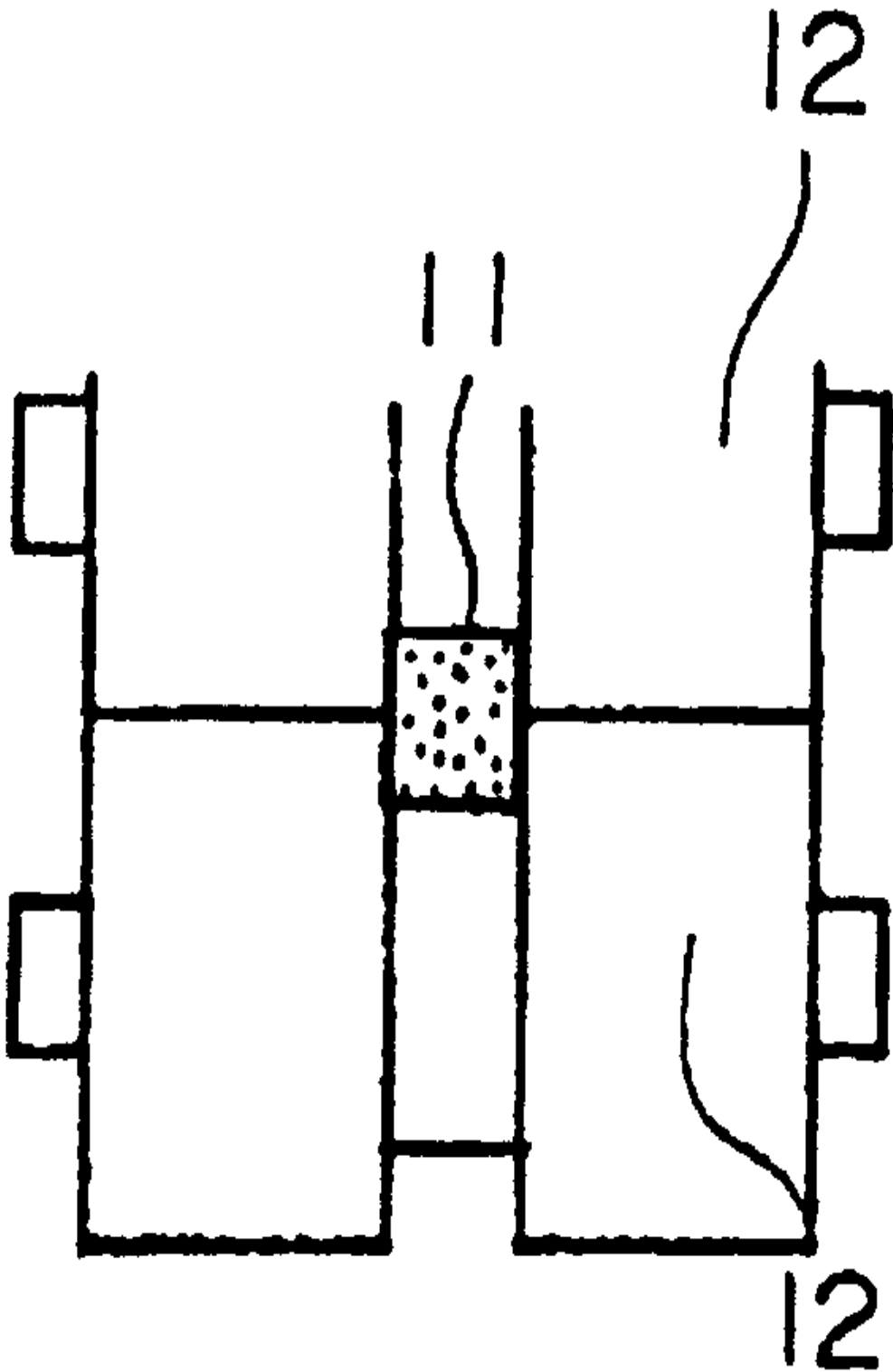

7

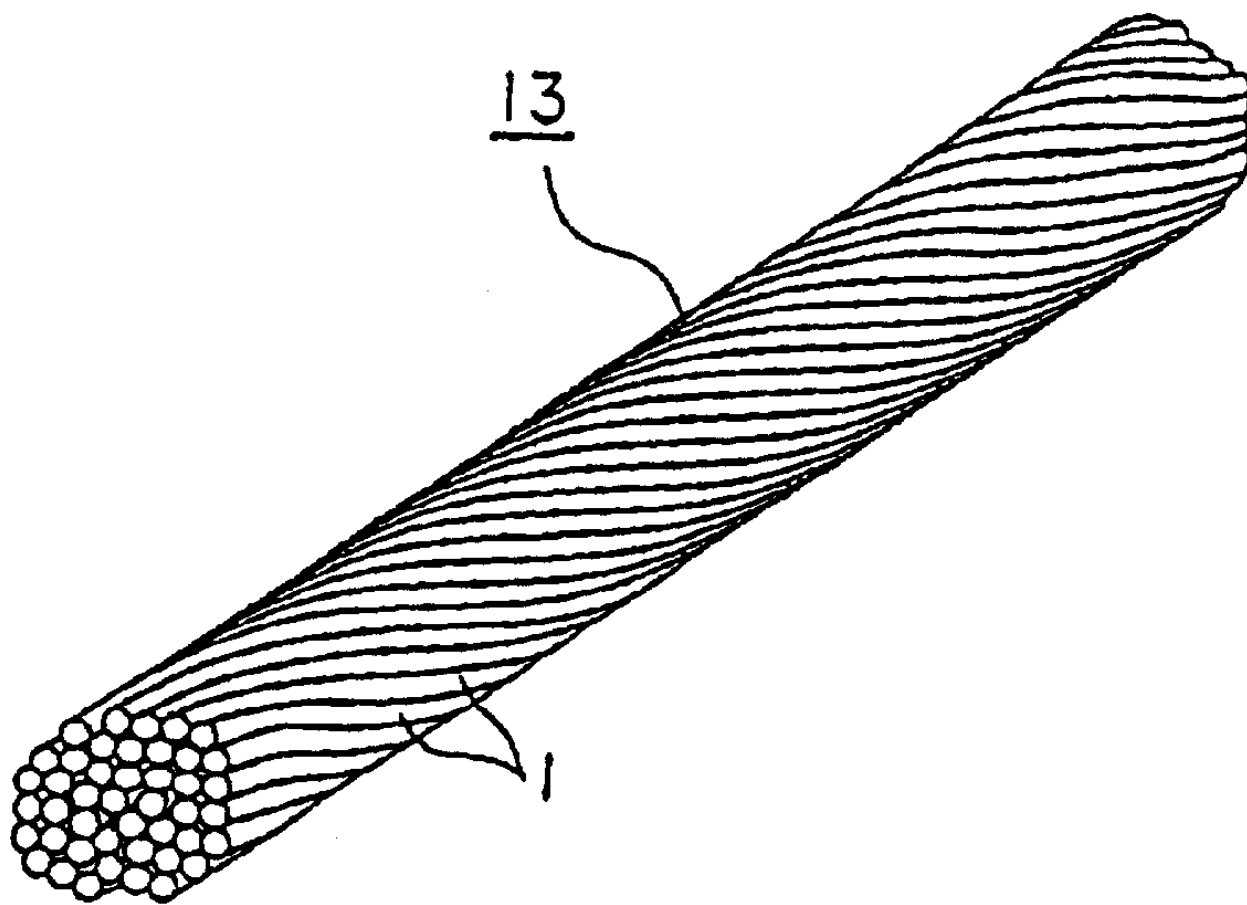

8

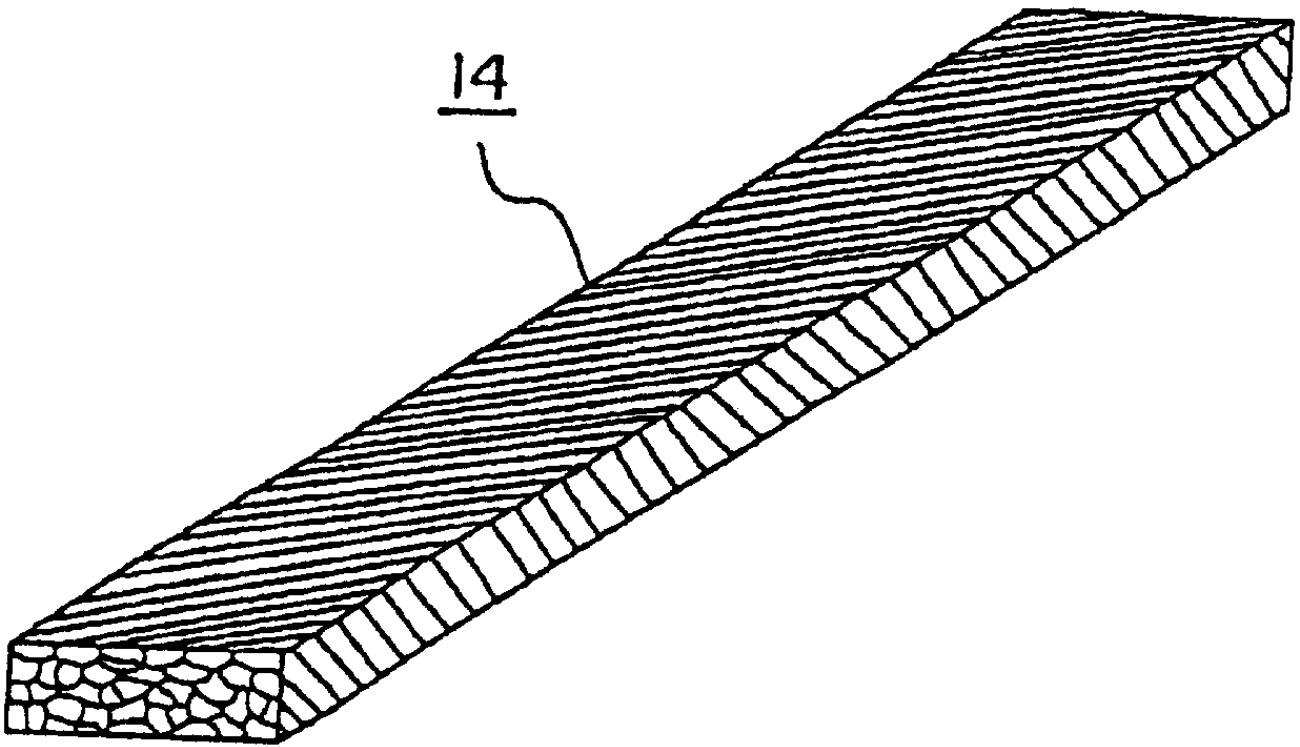

9

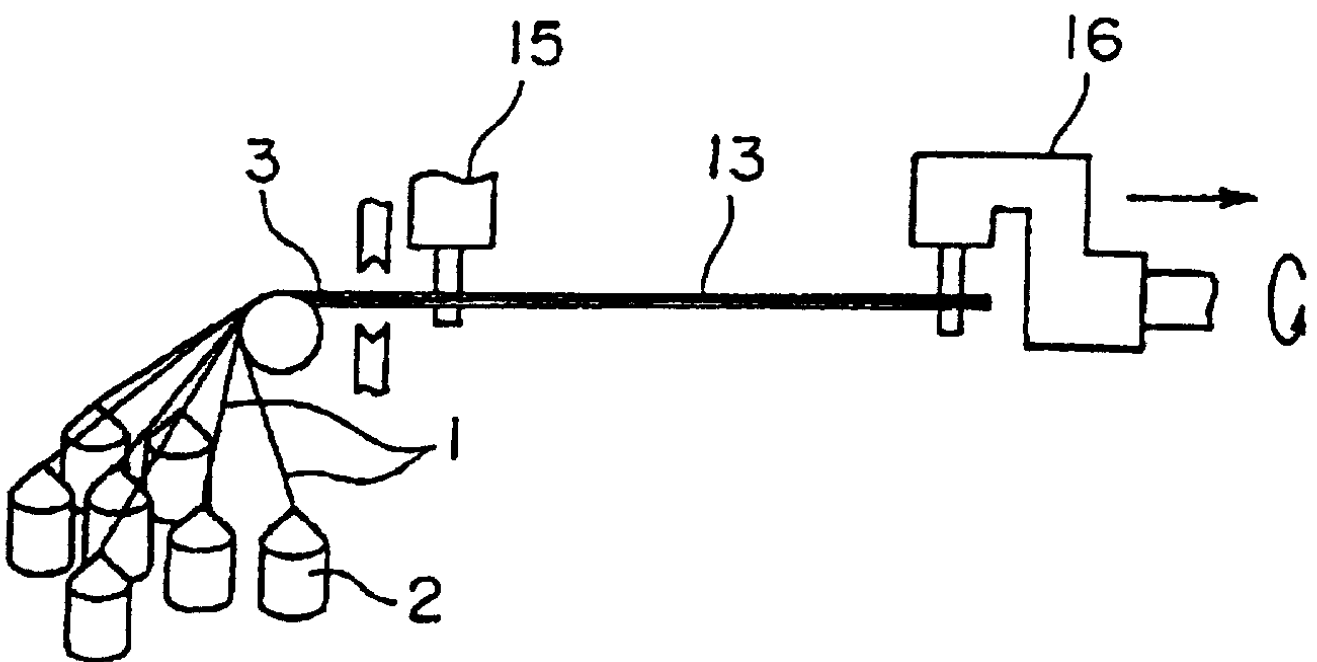

10

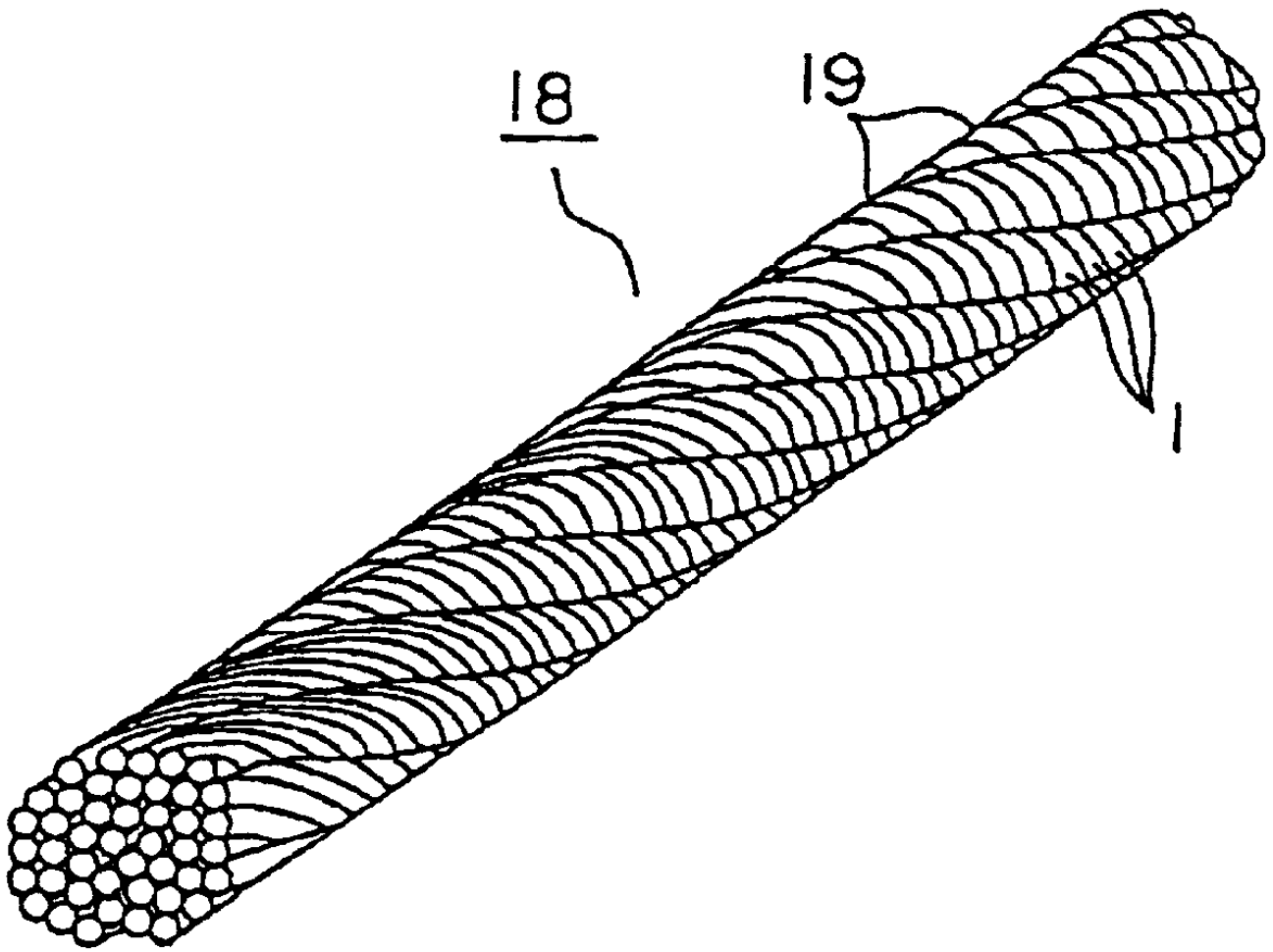

11

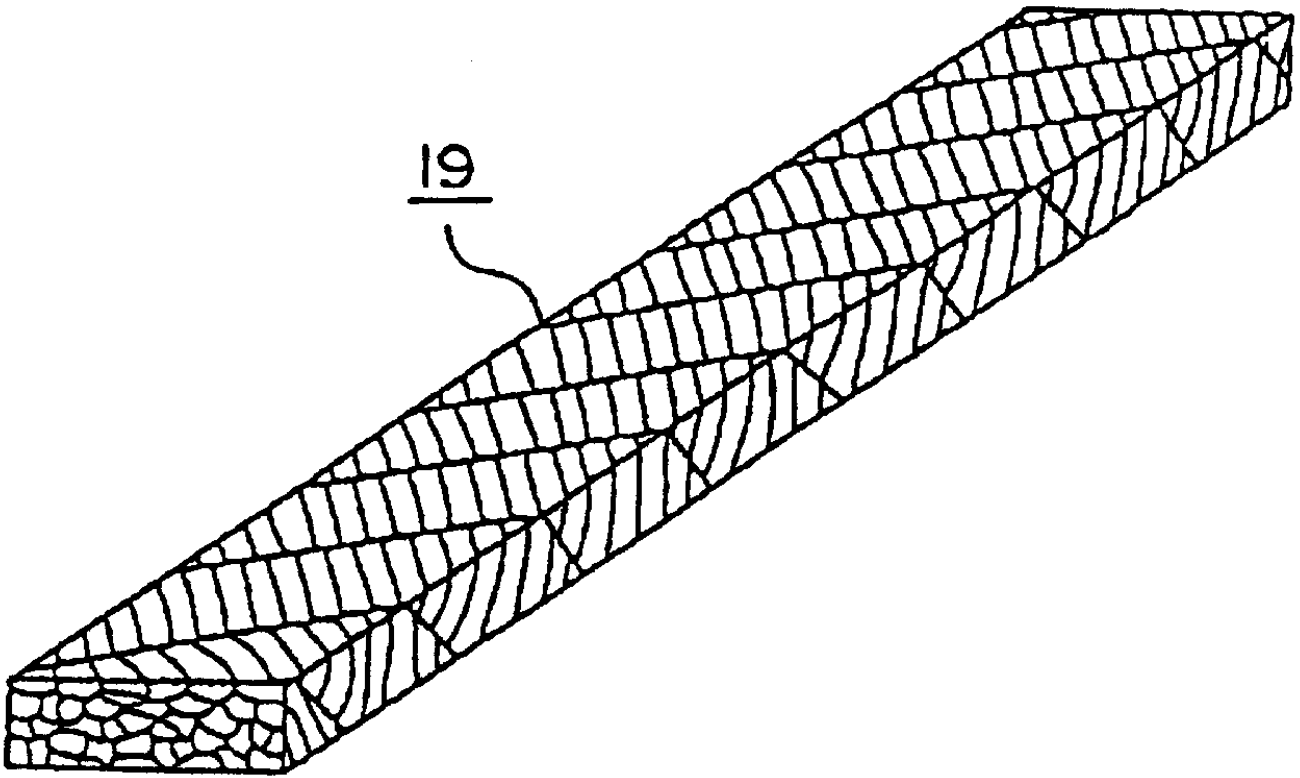

12

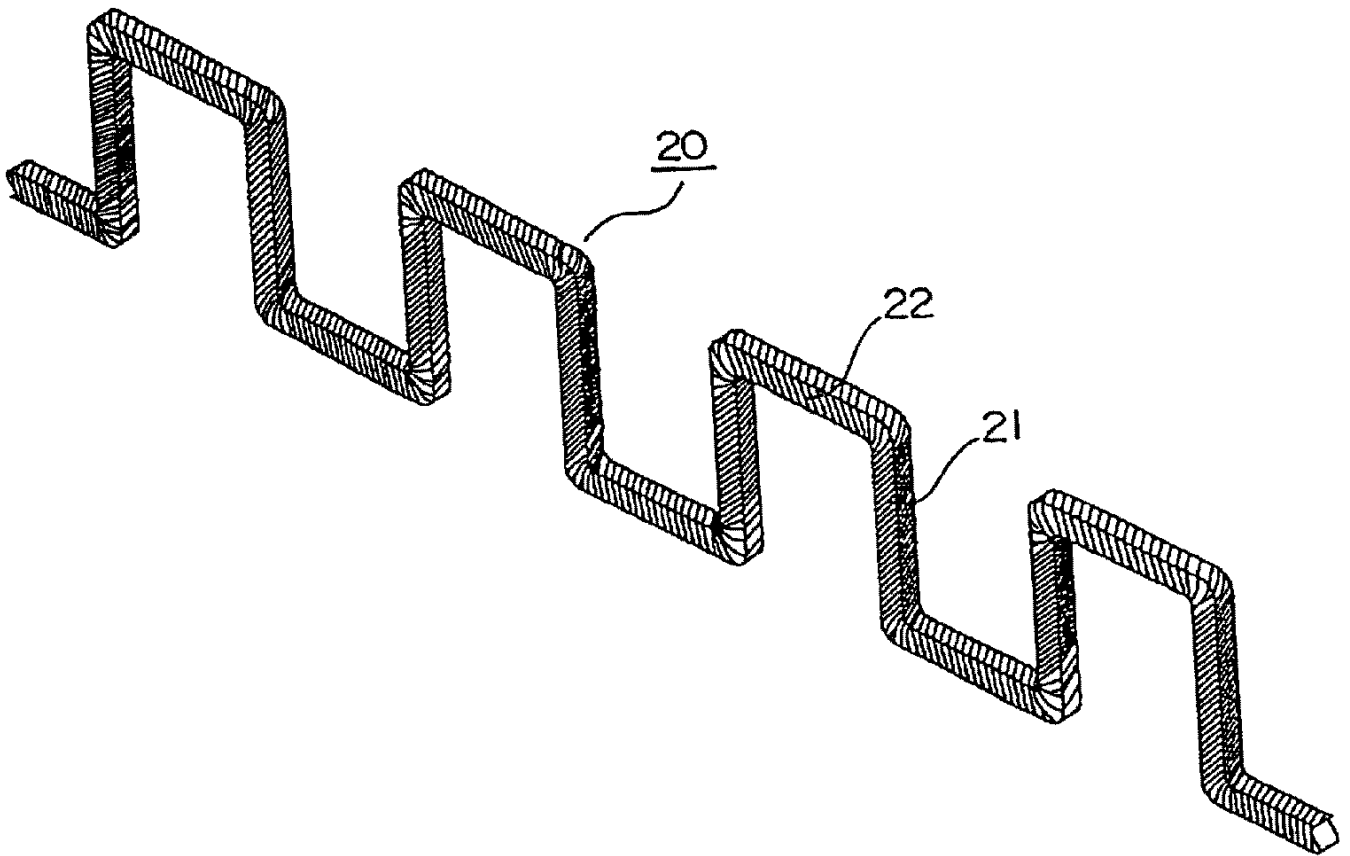

13

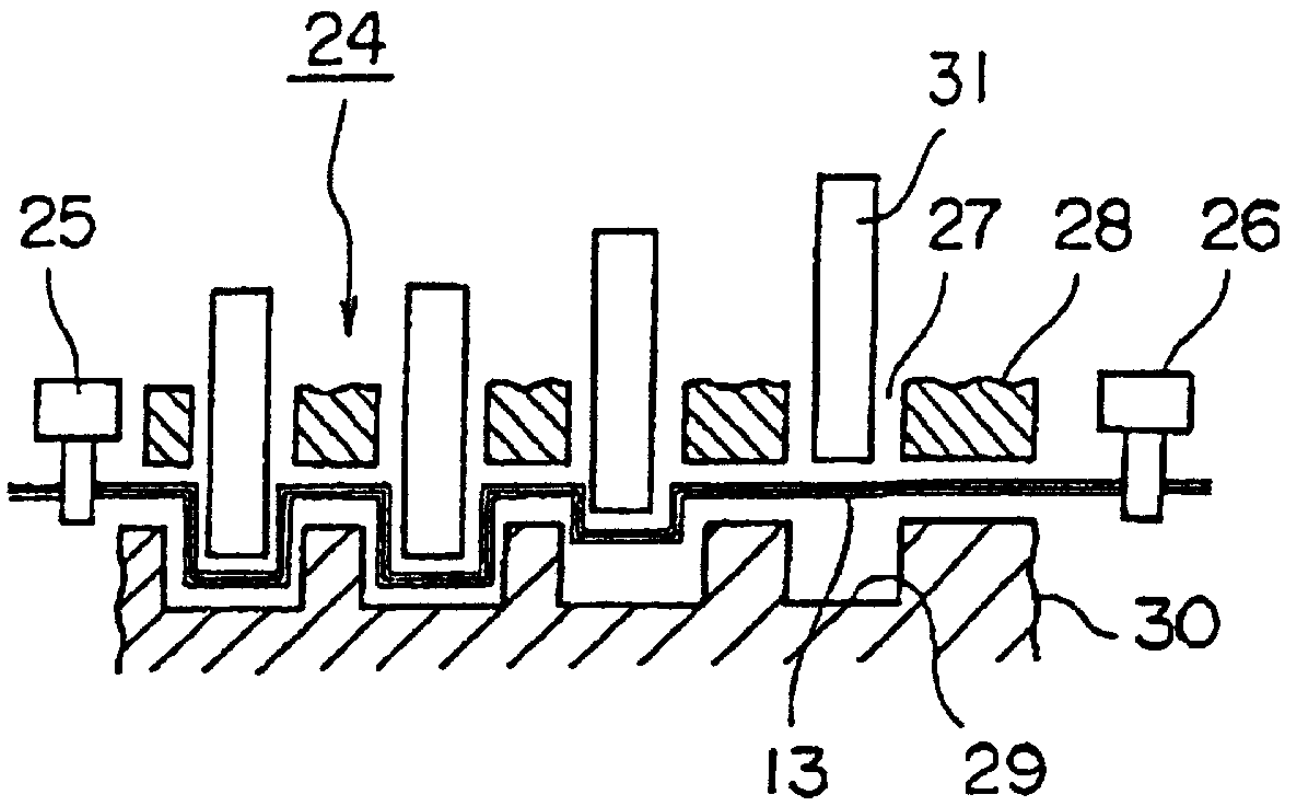

14

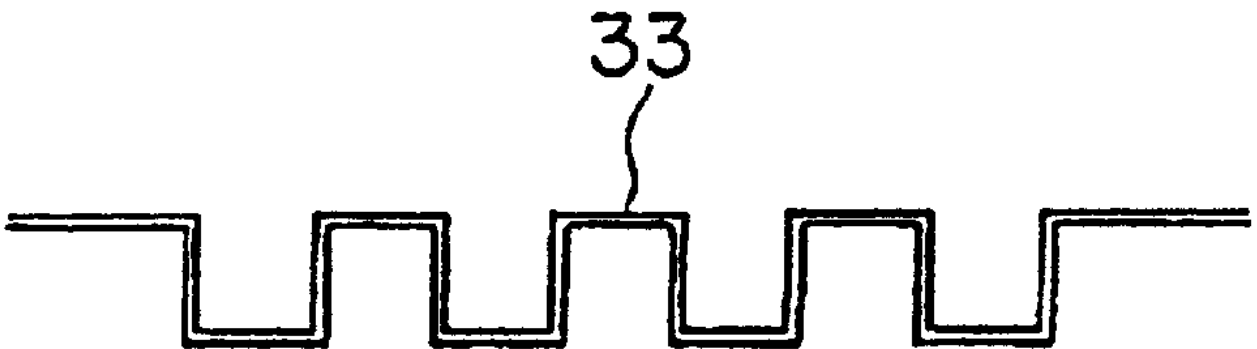

15

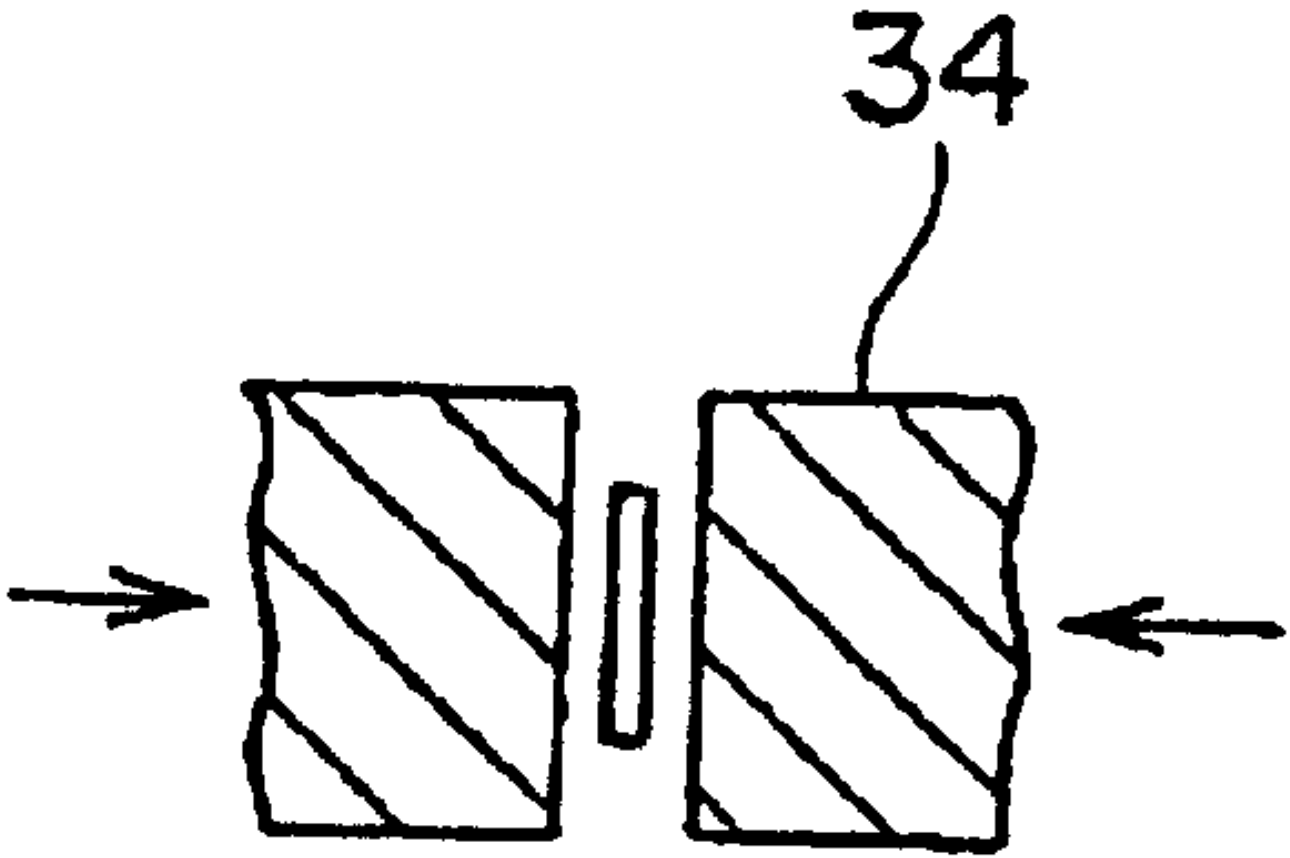

16

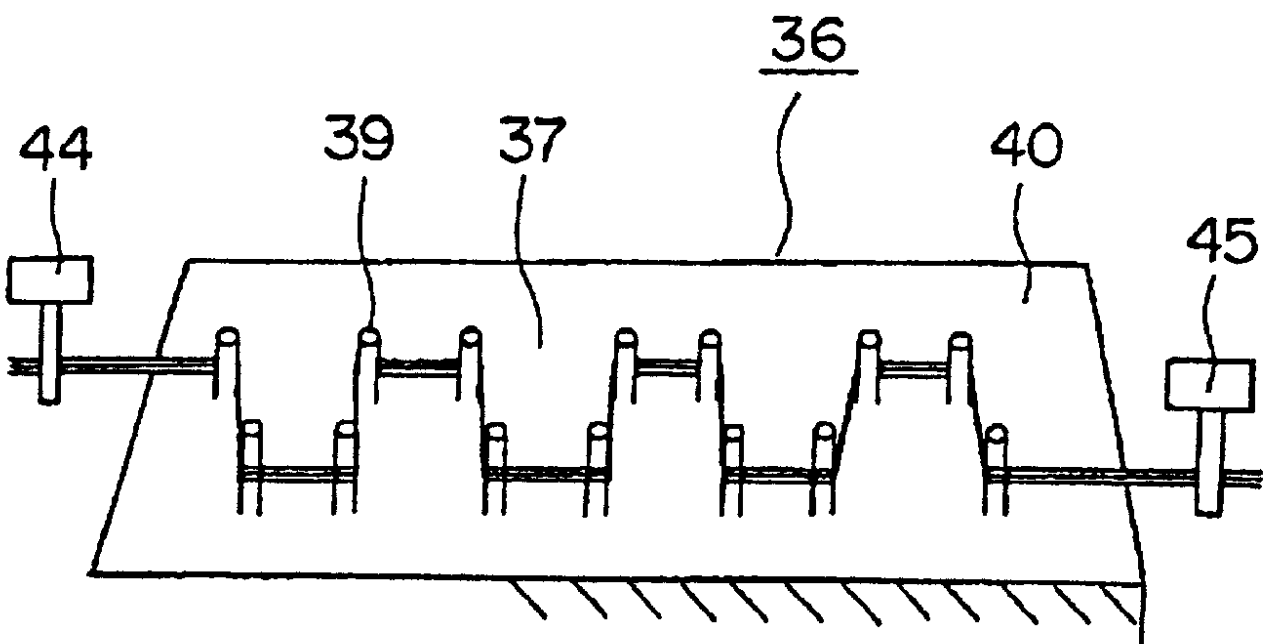

17

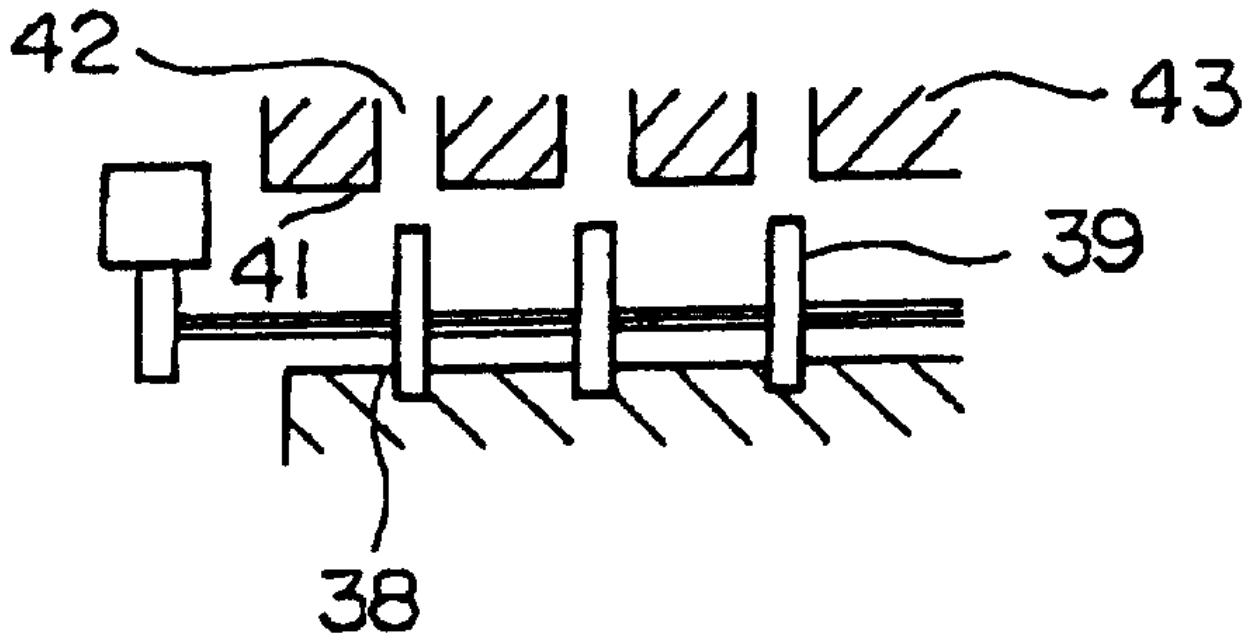

18

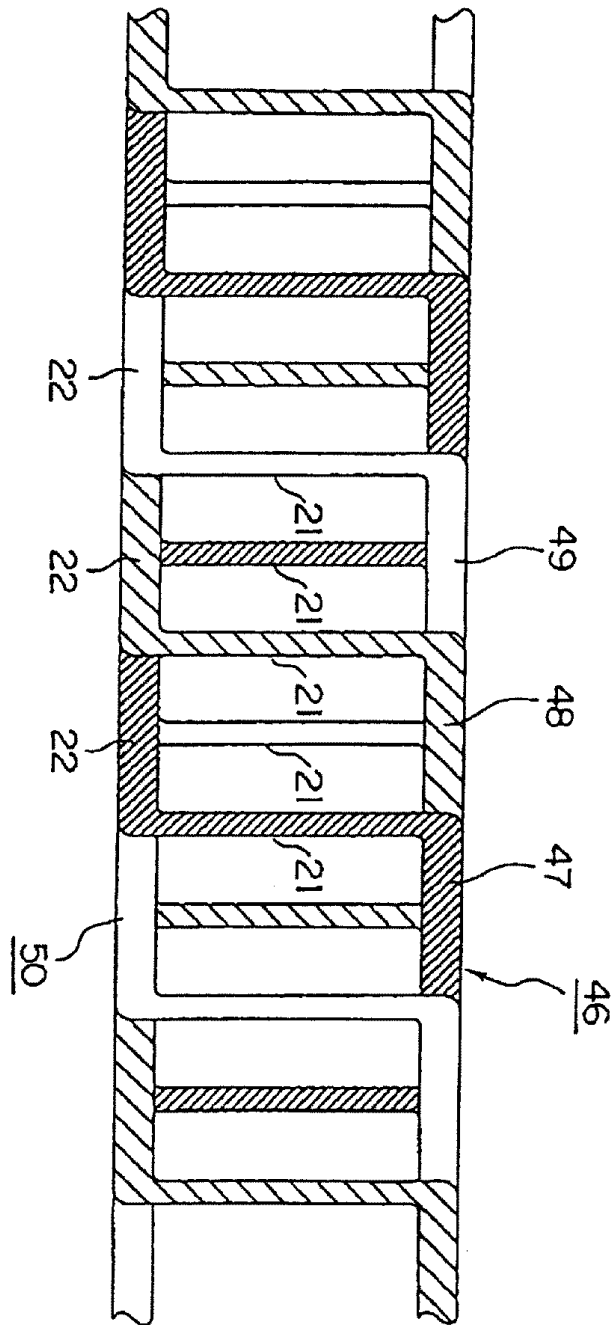

19

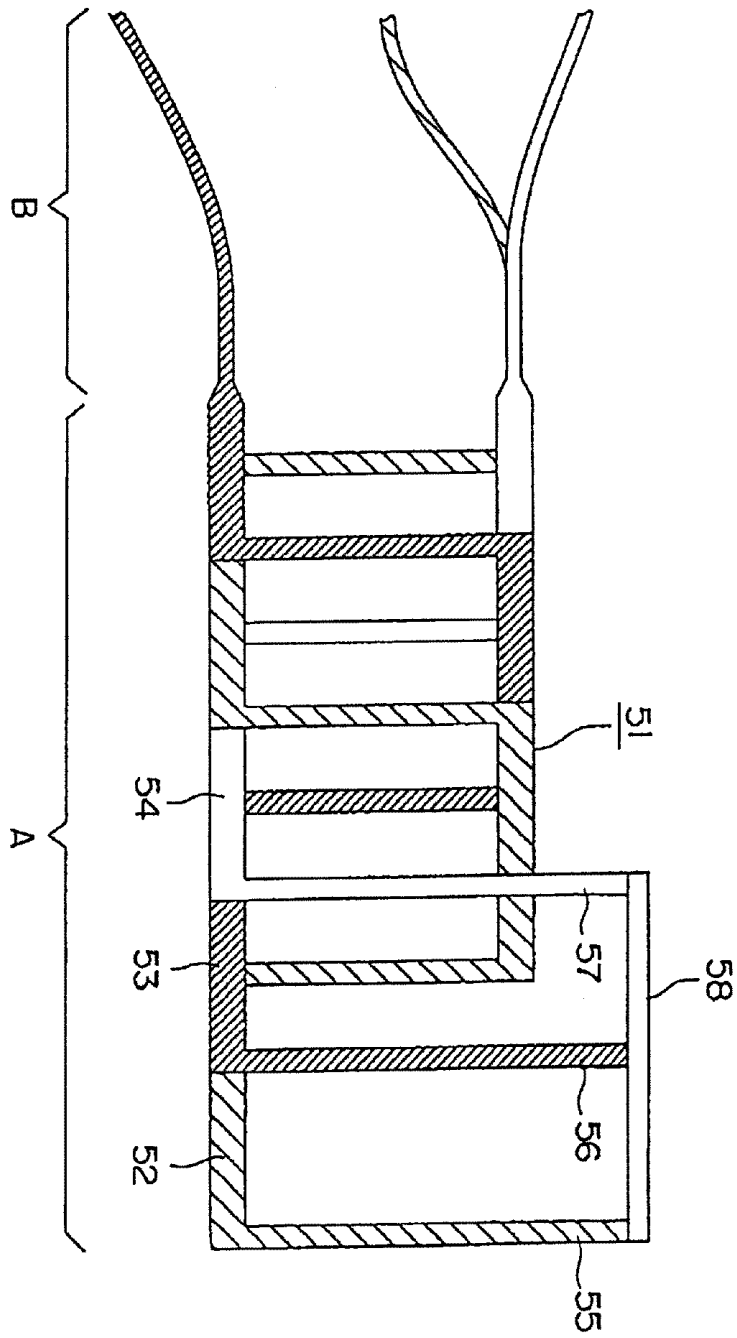

20

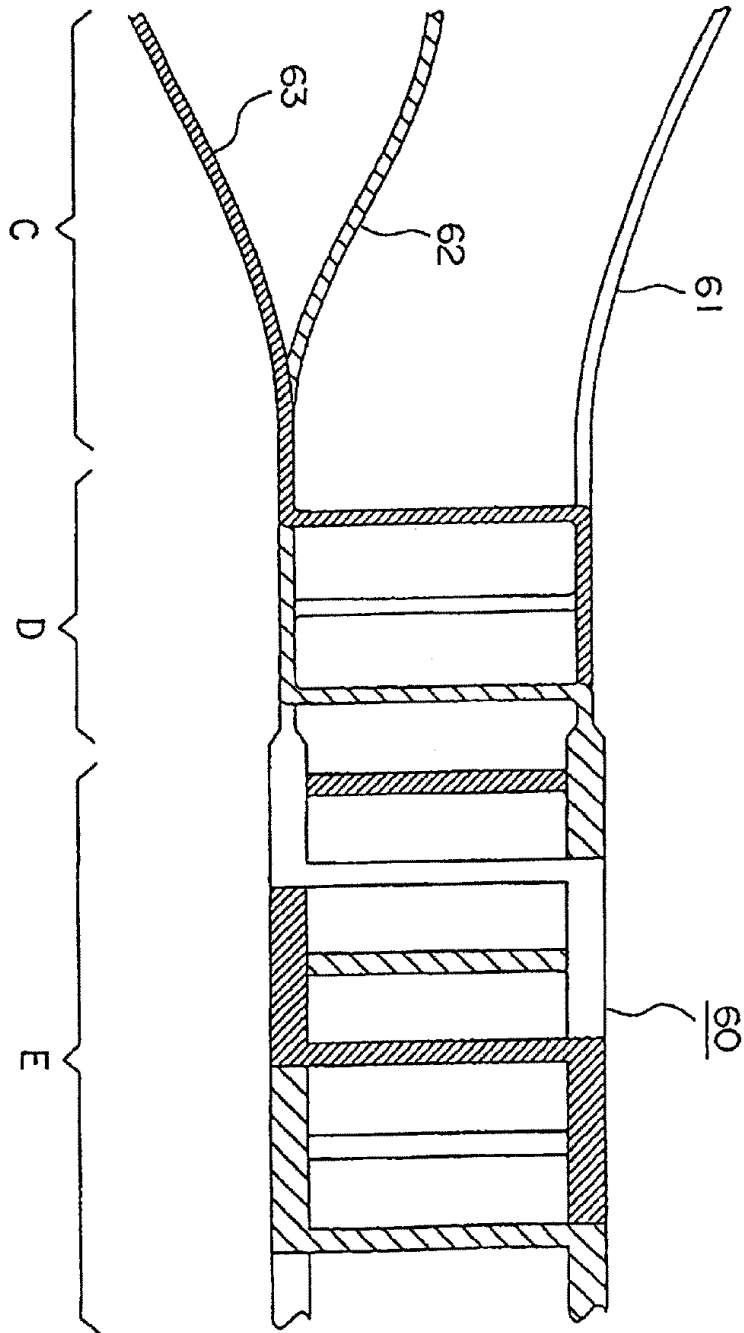

21

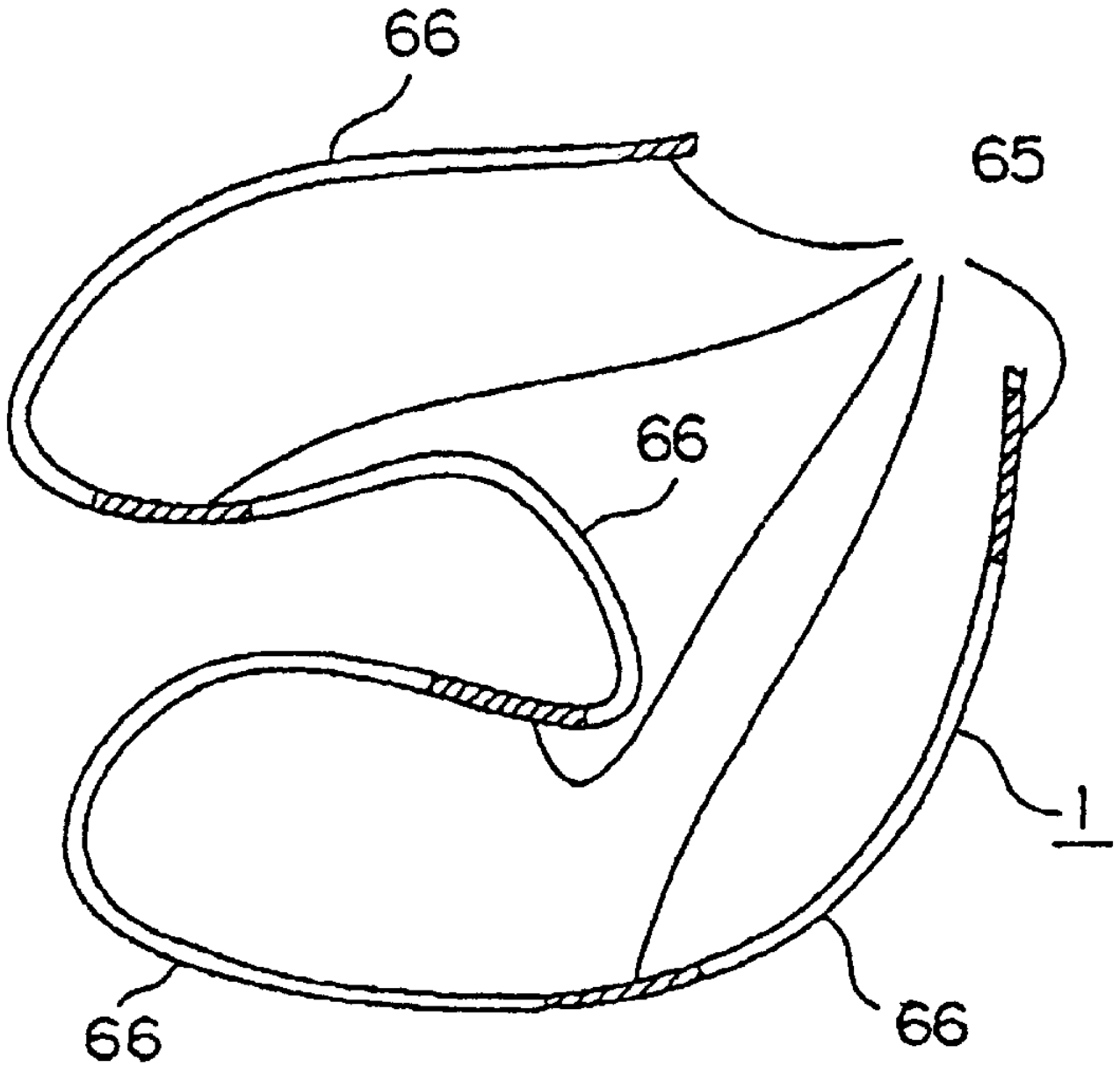

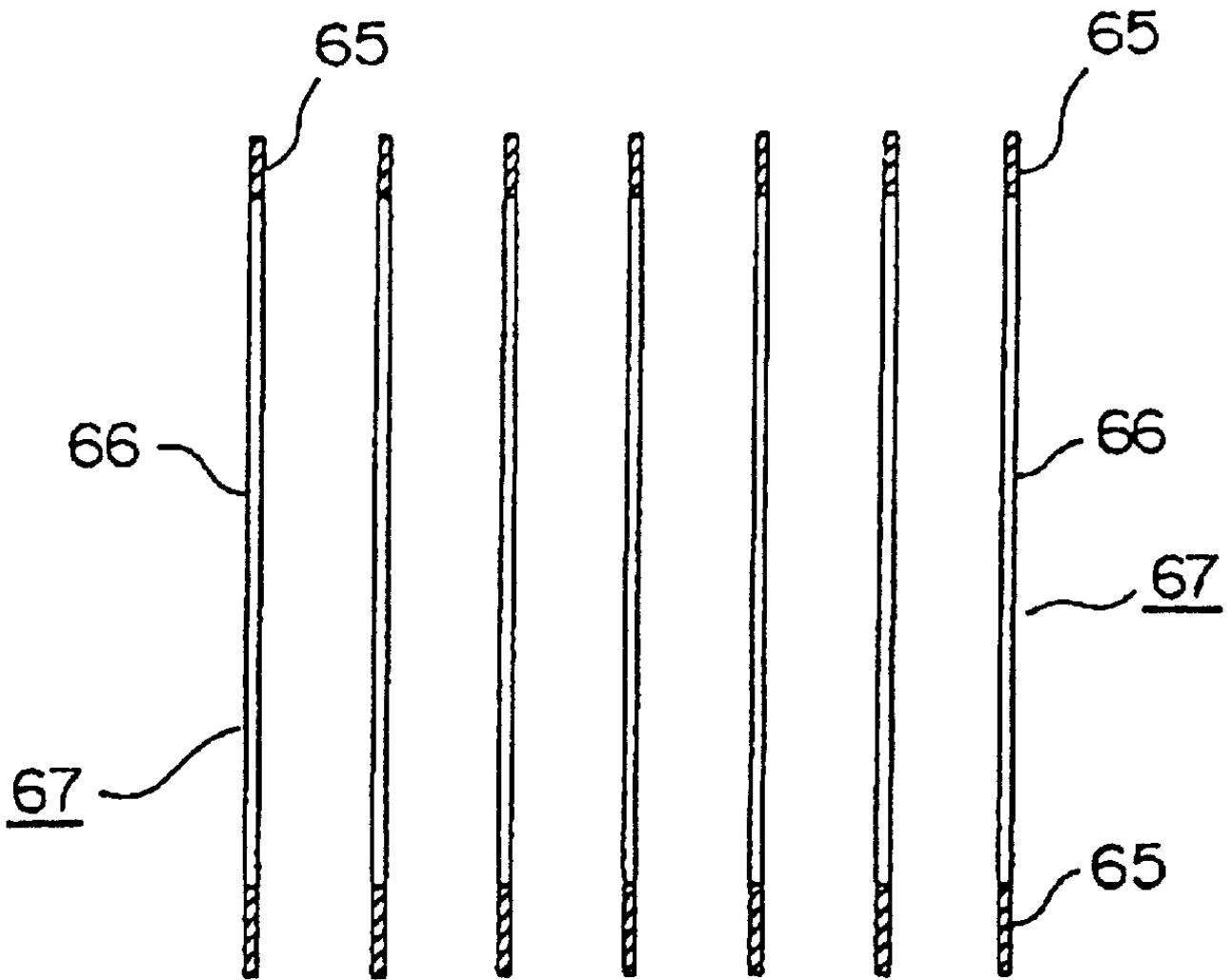

23

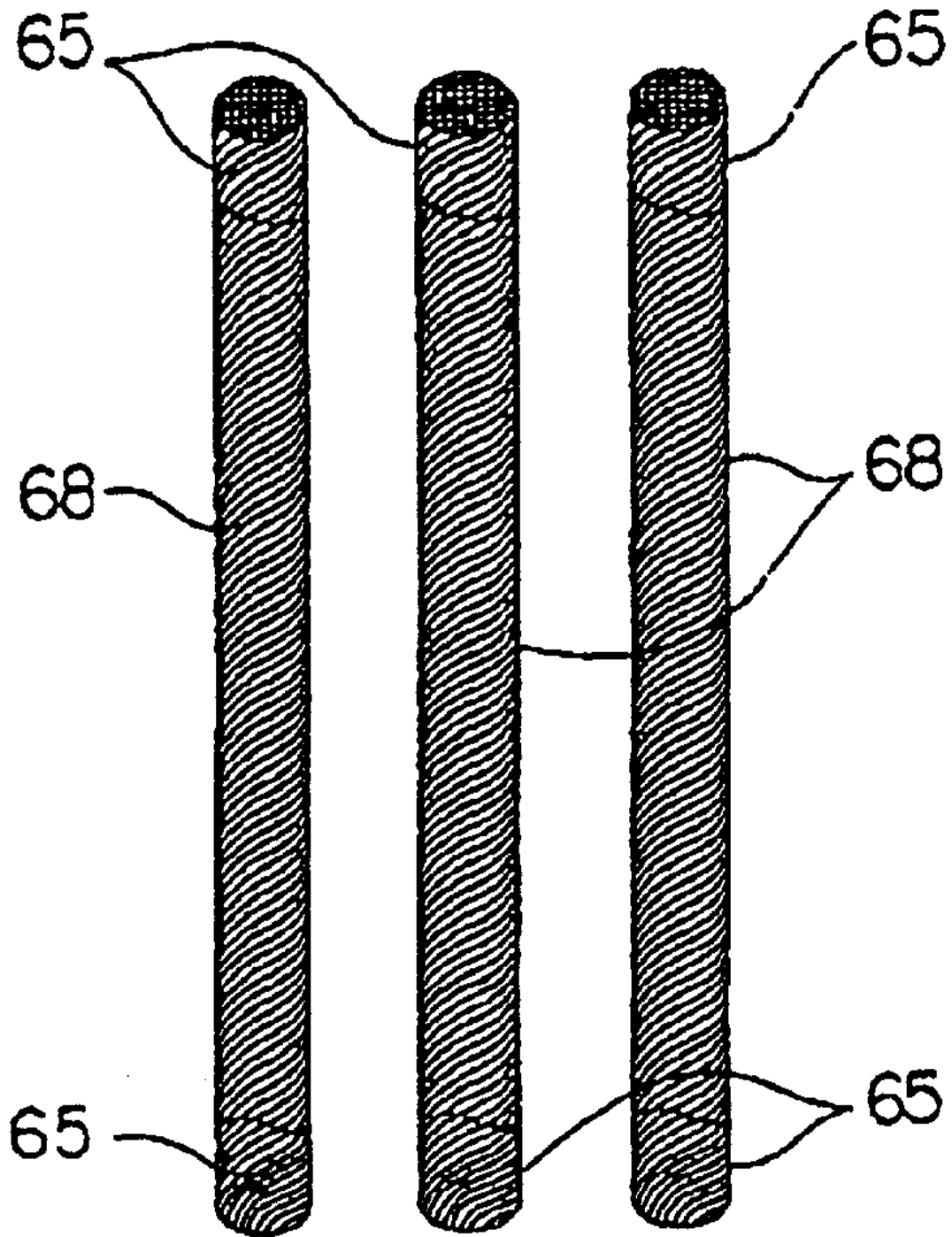

24

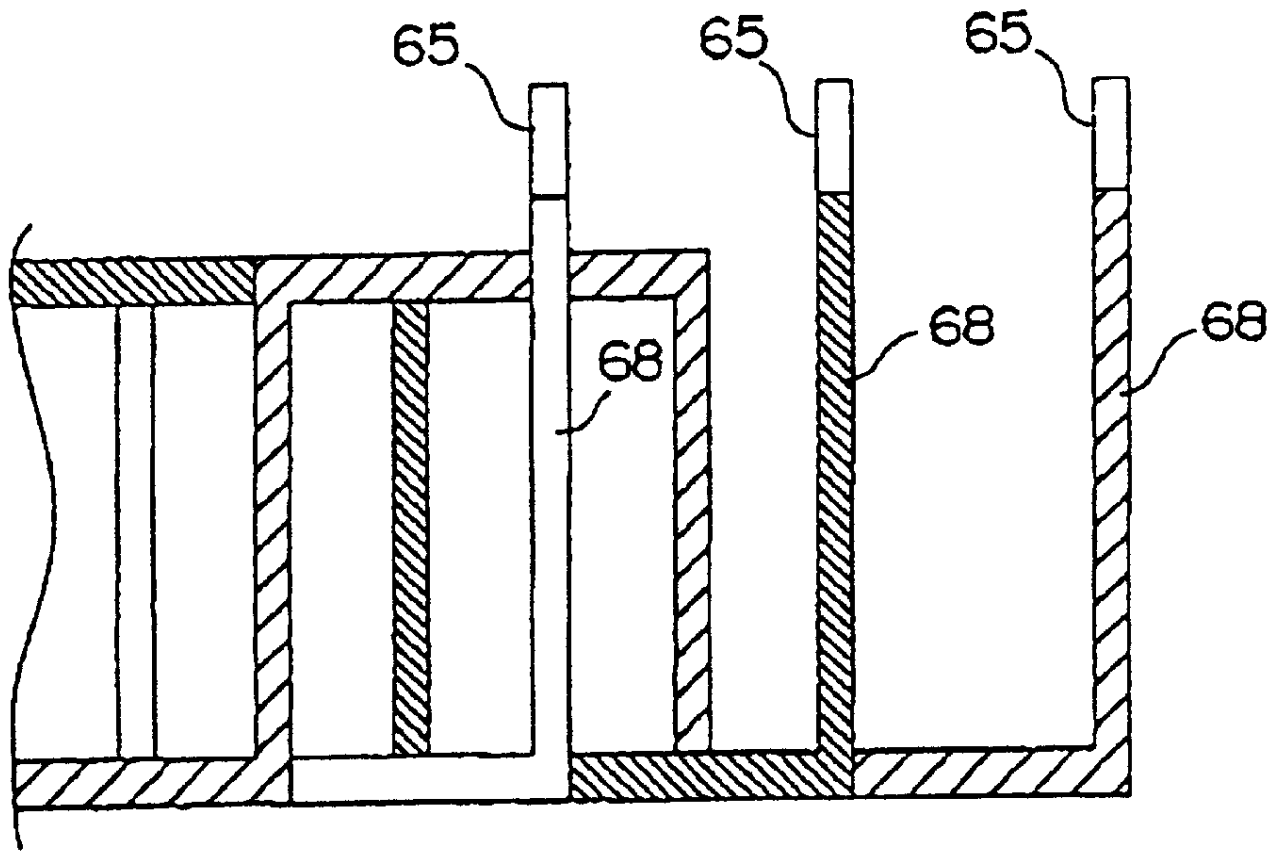

25

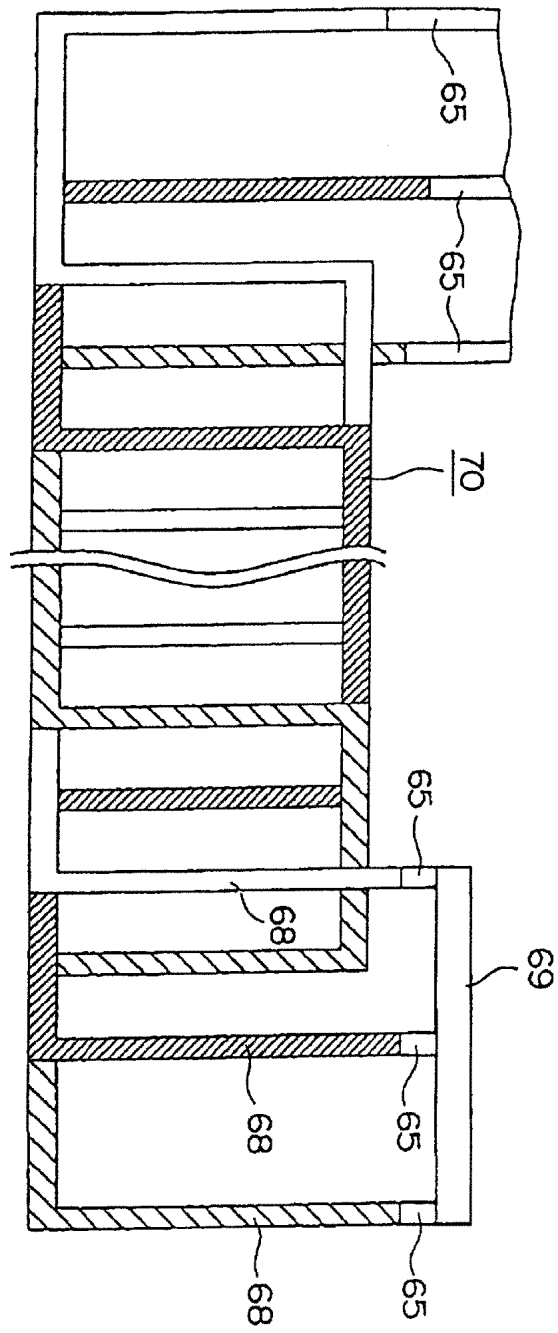

26

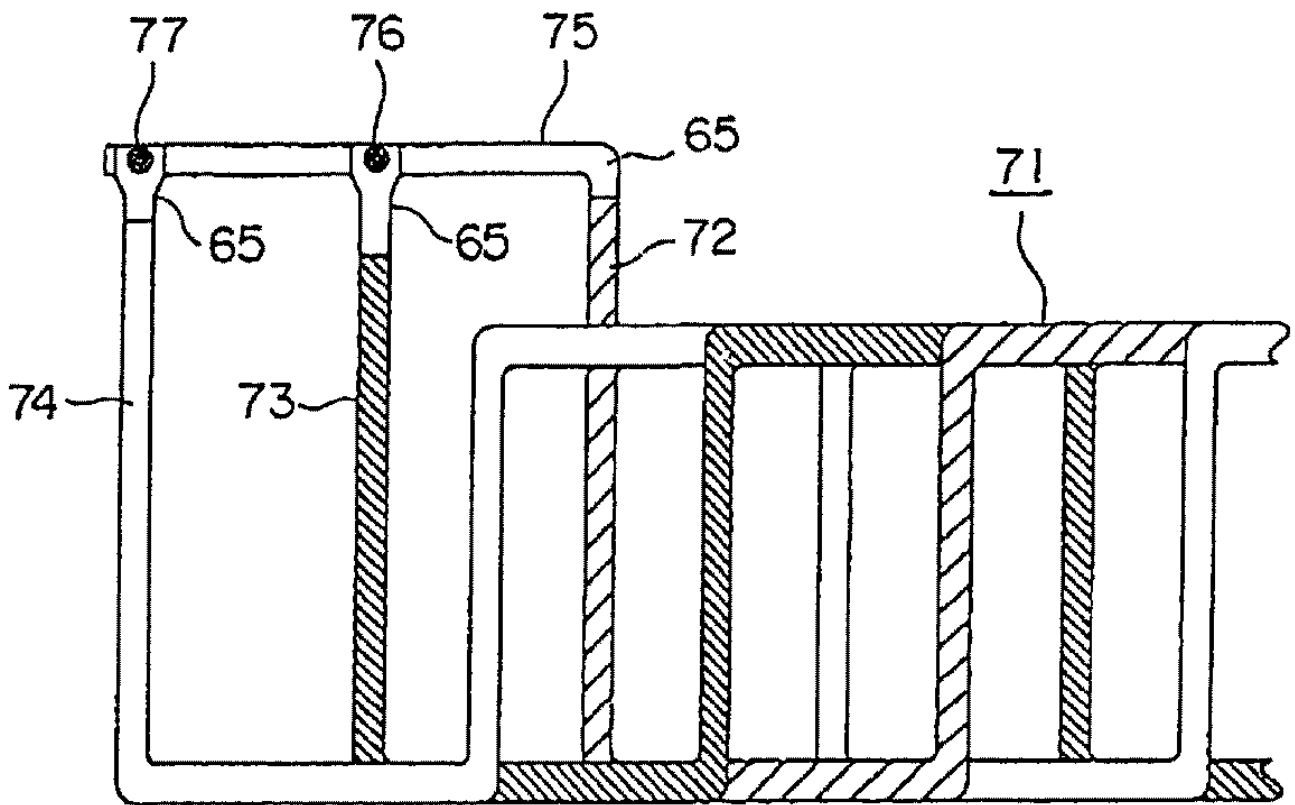

27

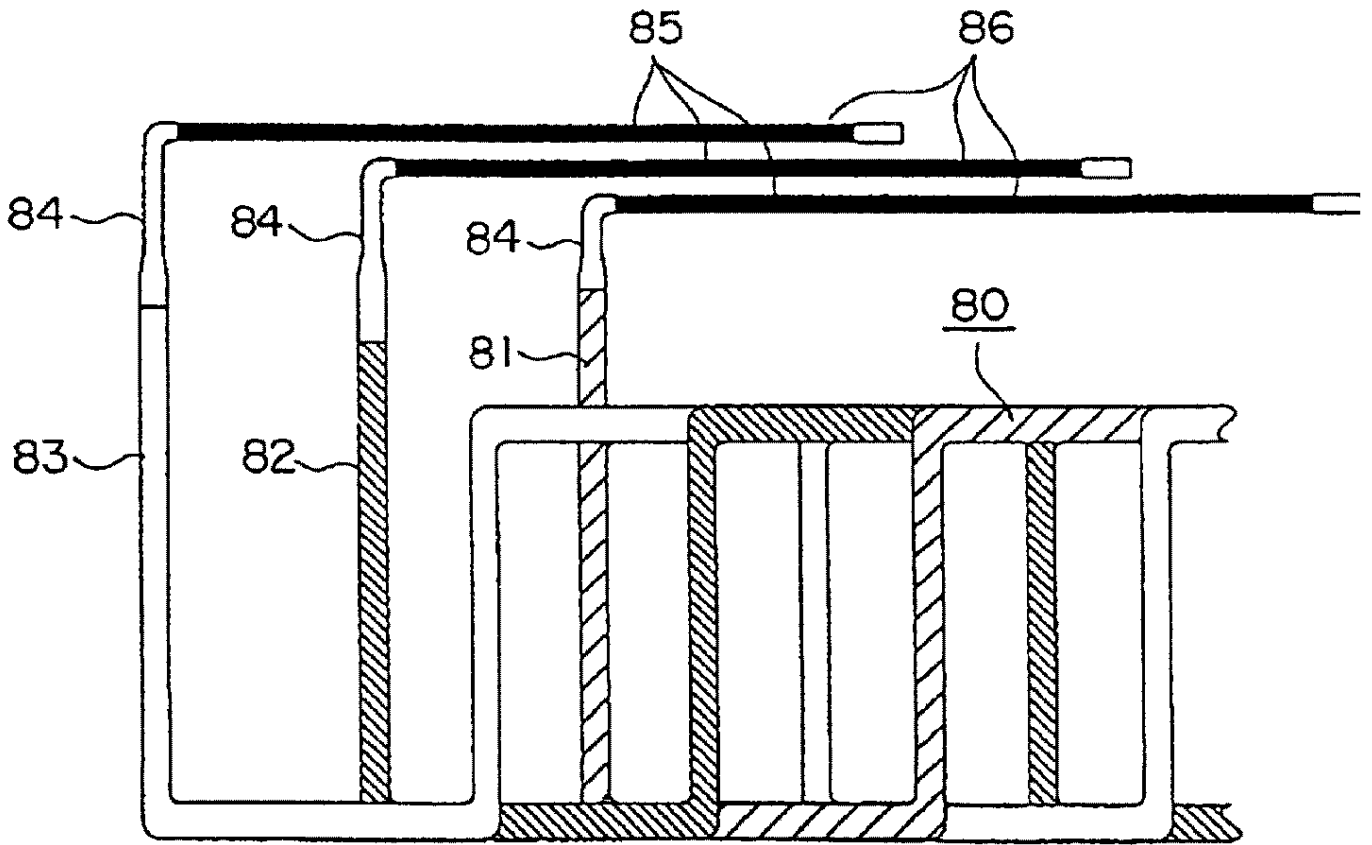

28

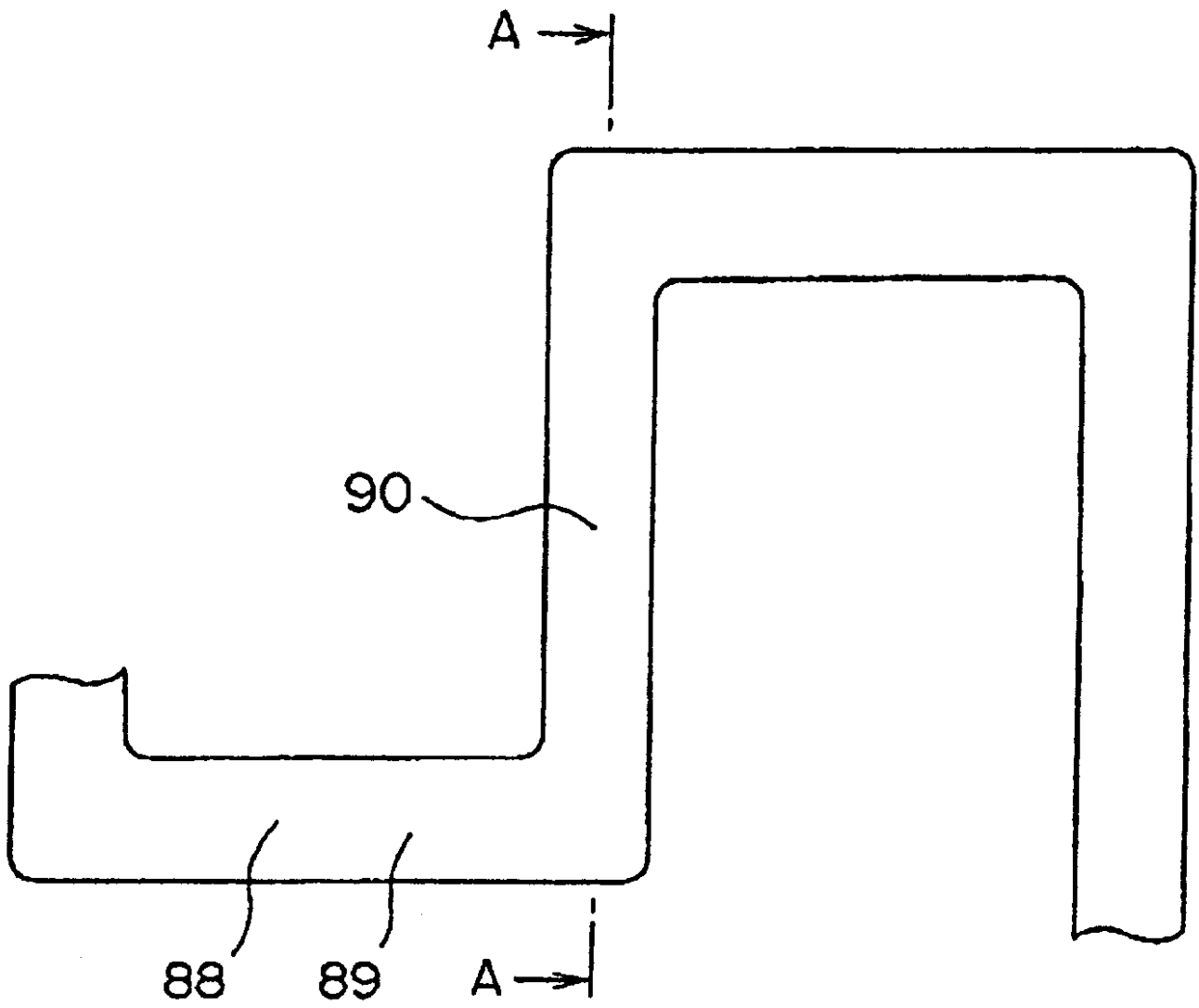

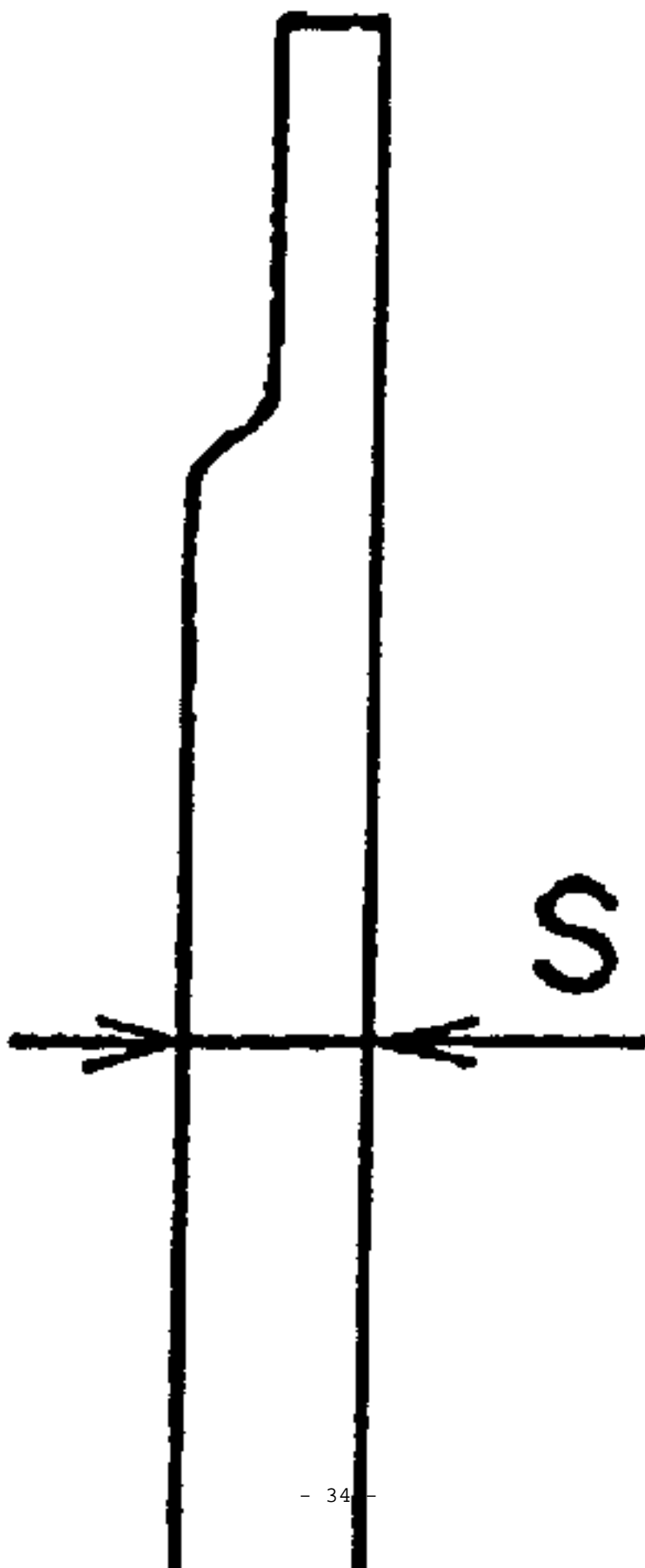

30

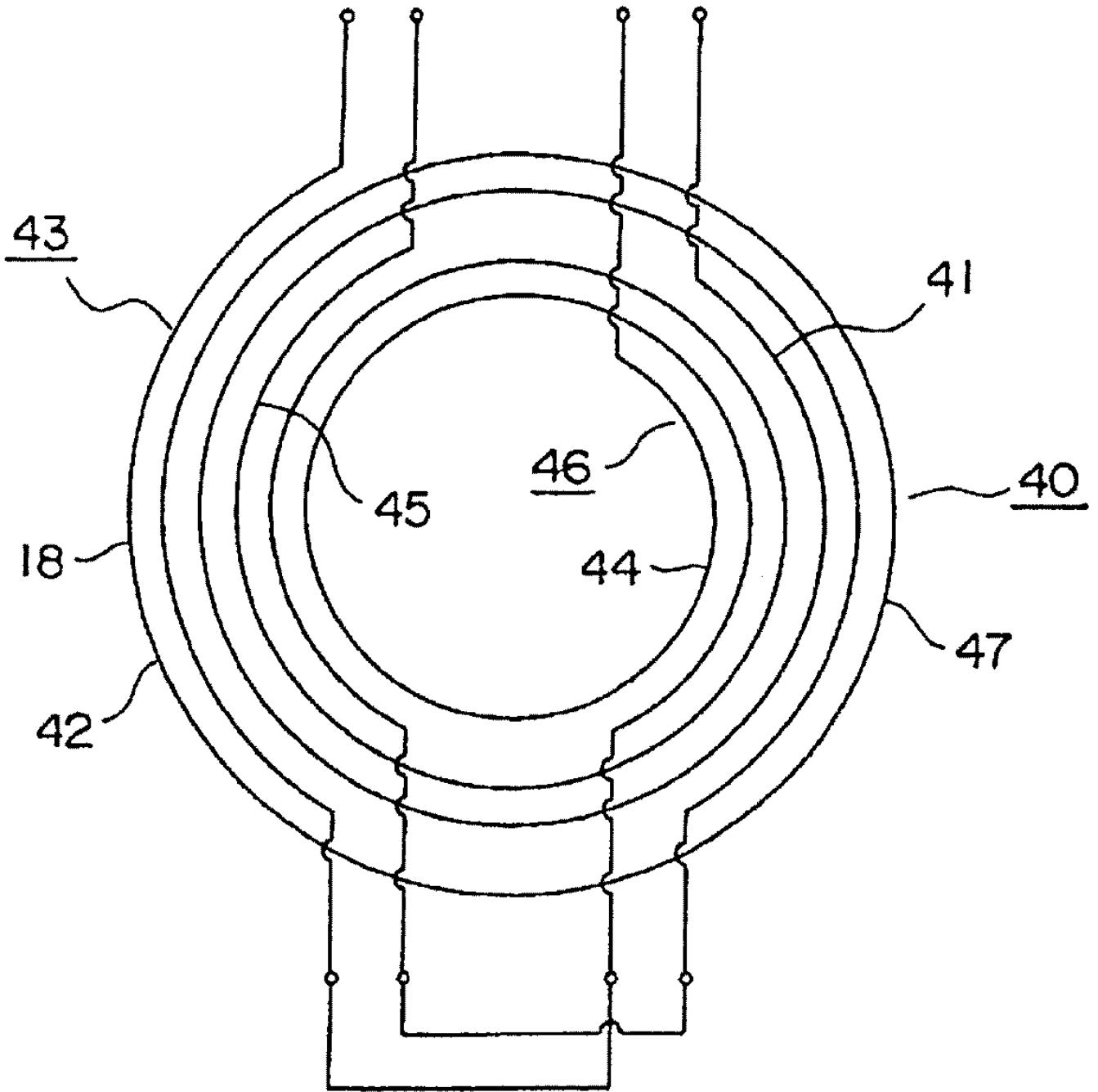

31

