

(No Model.)

3 Sheets—Sheet 1.

J. WOLF, Jr.
CLOTH CUTTING MACHINE.

No. 528,217.

Patented Oct. 30, 1894.

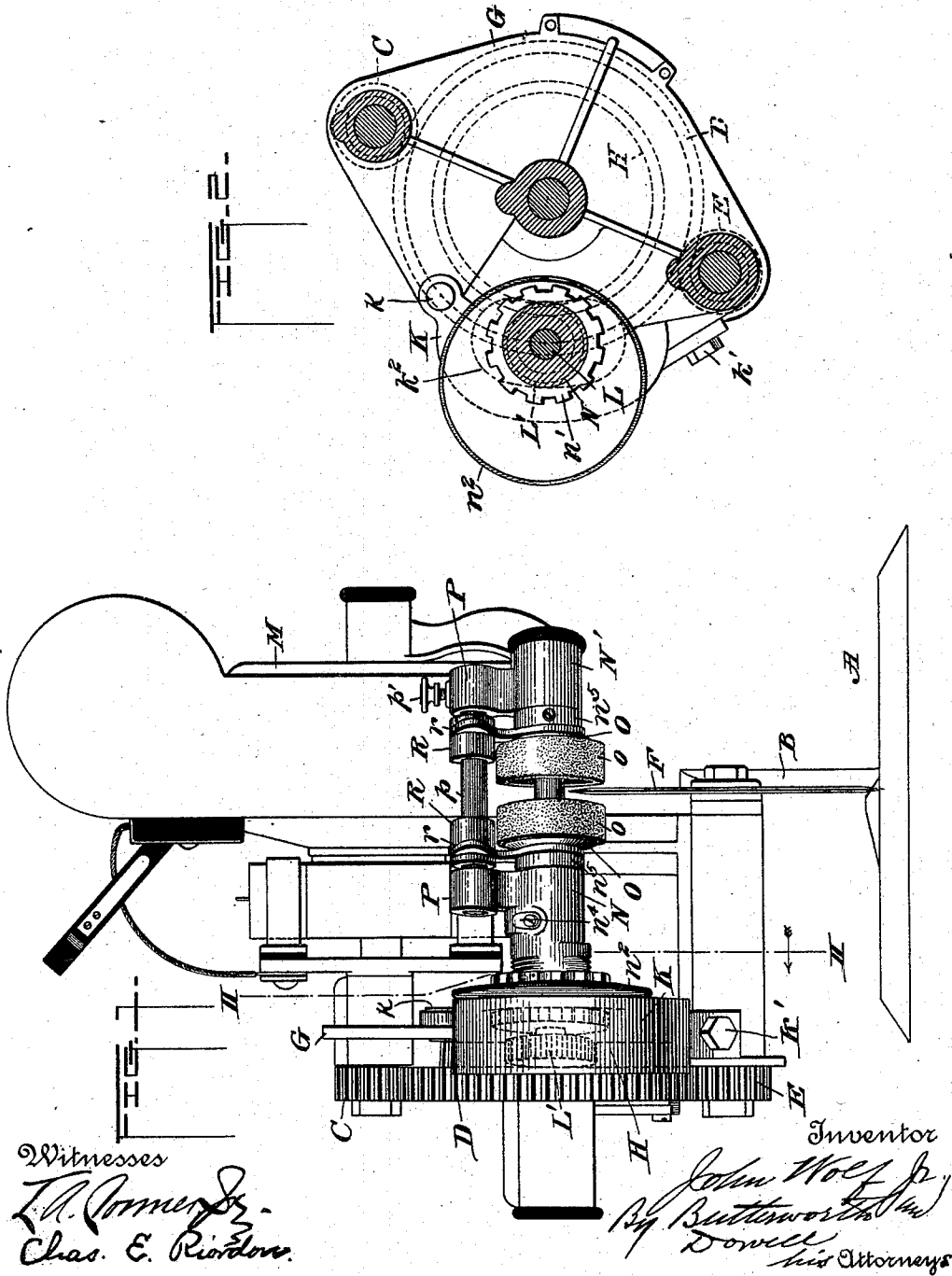

(No Model.)

3 Sheets—Sheet 2.

J. WOLF, Jr.
CLOTH CUTTING MACHINE.

No. 528,217.

Patented Oct. 30, 1894.

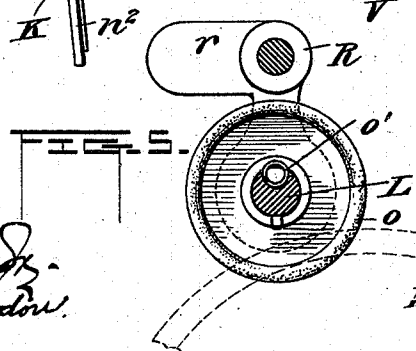
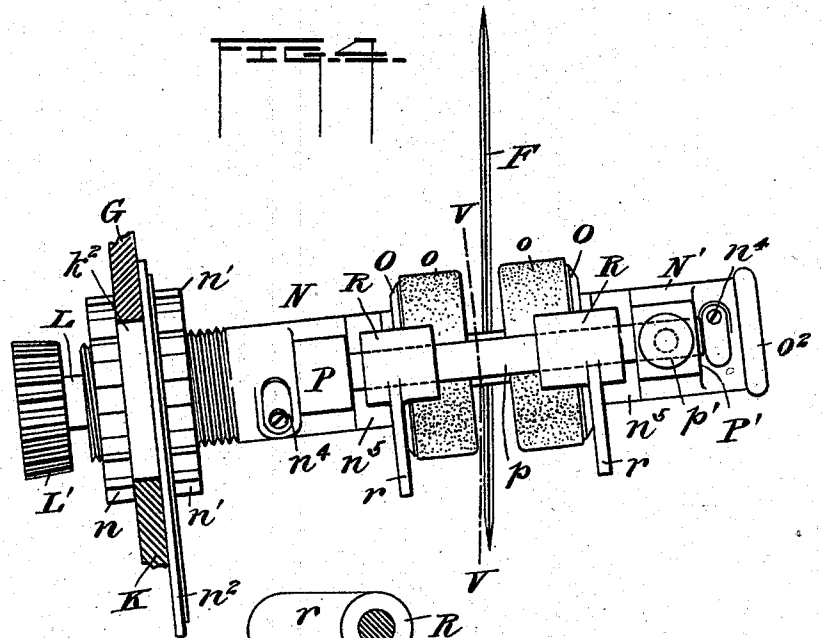
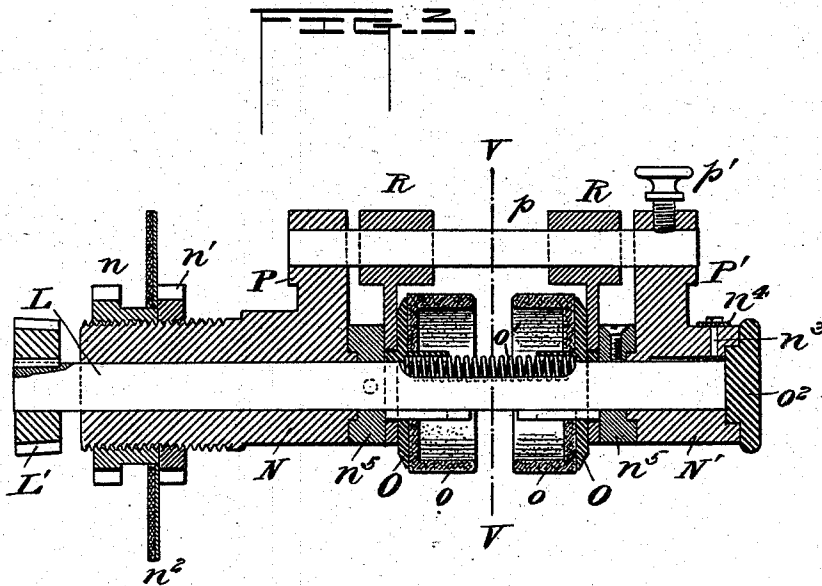

Witnesses
T. A. Comer
Chas. E. Riordan

Inventor
John Wolf Jr.
 By *Bullerworth*
 and *Dowell*
 his Attorneys.

J. WOLF, Jr.
CLOTH CUTTING MACHINE.

No. 528,217.

Patented Oct. 30, 1894.

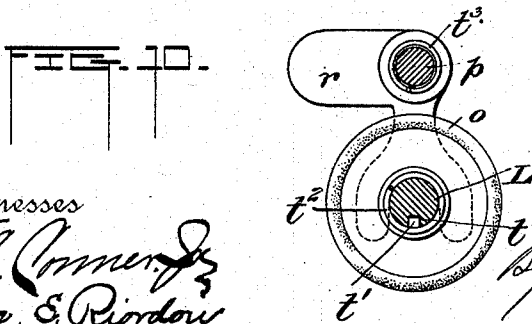
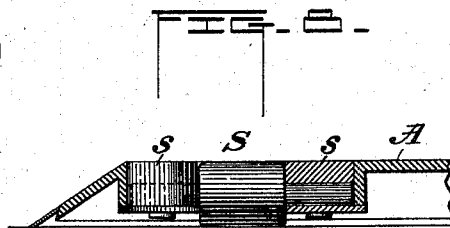
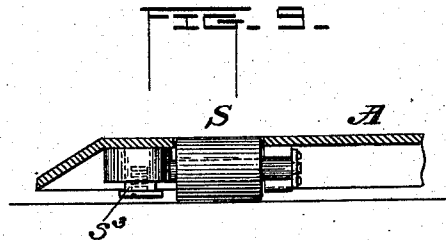
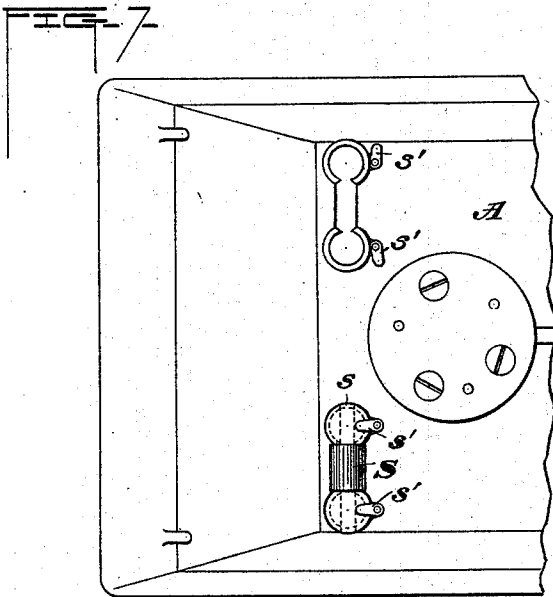
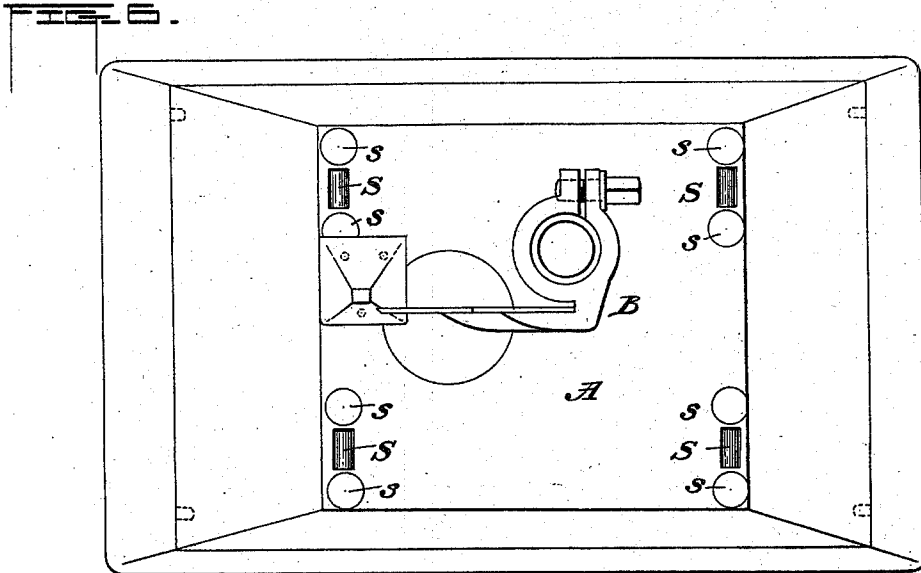

Witnesses
L. A. Conner, Jr.
Chas. E. Riordan.

Inventor
John Wolf, Jr.
 By *Ritterworth & Dowell*
 his Attorneys.

UNITED STATES PATENT OFFICE.

JOHN WOLF, JR., OF CINCINNATI, OHIO, ASSIGNOR TO THE WOLF ELECTRICAL PROMOTING COMPANY, OF SAME PLACE.

CLOTH-CUTTING MACHINE.

SPECIFICATION forming part of Letters Patent No. 528,217, dated October 30, 1894.

Application filed May 31, 1894. Serial No. 513,004. (No model.)

To all whom it may concern:

Be it known that I, JOHN WOLF, Jr., a citizen of the United States, residing at Cincinnati, in the county of Hamilton and State of Ohio, have invented certain new and useful Improvements in Cloth-Cutting Machines; and I do hereby declare the following to be a full, clear, and exact description of the invention, such as will enable others skilled in the art to which it appertains to make and use the same.

This invention relates to machines or devices for cutting textile fabrics and other material, but more particularly to a class of machines especially designed for cutting cloth for the manufacturers of wearing apparel.

The primary object of the invention is to improve certain features in the construction and arrangement of parts of the cloth-cutting machine shown and described in the Letters Patent of the United States granted to myself September 26, 1893, No. 505,690.

Further objects of the invention are to provide simple and effective means whereby the sharpening device may be readily applied to or removed from the machine and adjusted for sharpening the cutter; and to provide rollers for the foot-plate so that the same may be arranged to readily remove any dust or dirt that may accumulate around said rollers.

With these objects in view the invention consists in the construction and combination of the several parts, as will be more fully hereinafter described and then defined in the claims at the end of the description.

Reference being had to the accompanying drawings forming a part of this specification; Figure 1 is a front elevation of the machine illustrating the position the sharpening device assumes with relation to the cutter. Fig. 2 is a vertical sectional elevation on the line II—II of Fig. 1. Fig. 3 is a vertical sectional view of the sharpening device detached from the machine. Fig. 4 is a plan view of the sharpening device, showing how the same is secured to the machine and the relative positions of the cutter to said device. Fig. 5 is a vertical sectional elevation on the line V—V of Figs. 3 and 4. Fig. 6 is a plan view of the

foot-plate and standard with the upper portion of the machine removed, illustrating the position of the rollers. Fig. 7 is a fragmentary inverted plan view of Fig. 6 with one of the rollers in position and the other removed. Fig. 8 is a fragmentary sectional elevation of the foot-plate and the roller and means for retaining the same to the foot-plate. Fig. 9 is a modified form of the roller and means for securing the roller to the foot-plate; and Fig. 10 illustrates a slightly modified form of shaft and means for forcing the cutter disks normally apart.

In the drawings A designates a foot-plate of a suitable construction having extending upwardly therefrom a standard B upon which is supported a frame carrying an electric motor M. This motor has its driving or armature shaft suitably journaled in the frame and has arranged on its end a spur gear C which is in mesh with the intermediate gear D which in turn meshes with the small gear E, the latter being secured to the shaft upon which the cutter F is arranged and by which the said cutter is revolved.

The shafts of the train of gearing pass through and have a bearing in a plate or yoke G substantially diamond shaped in formation and arranged upon the machine frame; the said plate forming a part of the casing which incloses the train of gearing, the casing not being shown in the drawings. The intermediate gear D has a gear wheel H, preferably slightly beveled, arranged upon the same shaft or formed integrally therewith, so as to rotate in unison with said gear. The plate or yoke G is provided with a section or cover K pivotally secured or hinged to said plate at k and which is secured at its lower end to the plate by a bolt k' . This section is so constructed as to provide a flush surface where the edge of same abuts against the edge of the plate G, both plate and section or cover having a slot k^2 partially formed in each and radially arranged with respect to the shaft of the intermediate gear wheel D for the purpose as will presently appear. Passing through the slot k^2 is a shaft L having arranged thereon a pinion L', preferably slightly beveled and adapted to mesh with the gear H by which said shaft is rotated in

an opposite direction to that of the cutter F. The shaft L is arranged obliquely with respect to the shaft of the cutter F and is provided at the ends thereof with sleeves or bearings N, N', the former having a screw-threaded end, engaging which are the nuts n, n' adapted to clamp the plate G and hinged section K between the opposed faces of said nuts, as best shown in Fig. 4. The nuts are preferably provided with a slotted periphery so that a spanner or wrench may be used for turning the nuts, though it is obvious that nuts having a polygonal surface may be employed if desirable. The nut n' has a guard n^2 placed between the abutting face of same and the plate and cover to prevent the passage of dust or other foreign matter through the slot k^2 into the casing which incloses the train of gearing and thereby materially interfering with the proper working of said gearing.

The sleeves N, N', are of sufficient length to form a proper bearing for the shaft L and are provided with apertures n^3 for properly lubricating the shaft, the said apertures having a cover n^4 for preventing the passage of dust through same to the shaft. Secured to the shaft L adjacent to the opposed faces of the sleeves or bearings N, N', are the collars n^5 each preferably provided with an annular groove in which is adapted to fit an annular projecting flange on the bearings which serve to provide a dust-proof joint between the collars and the bearings. Rotatably held and arranged to slide on the shaft by means of keys and splines are the disks O, O, having grinding wheels o, o , secured thereto, which are normally pressed apart by a spiral spring o' , preferably located in a groove in the shaft L and abutting against the opposed faces of said grinding wheel disks. The outer face of the bearing N' is provided with a cap o^2 which serves to close the end thereof. Projecting from the bearings N, N' are the brackets P, P', preferably formed integrally therewith in which is rigidly held a rod or shaft p , by means of a set screw p' or its equivalent. The shaft or rod p serves to retain the sleeves N and N' in a fixed position and in proper alignment with respect to each other. Slidingly held on the rod p are the pendent arms R arranged between the opposed faces of the brackets P, P', which engage with their lower ends the grinding wheel disks and have a handle r extending outwardly from the upper portion of each, for the purpose of readily bringing the grinding wheels together by merely grasping the handles by the hand and pressing them toward each other.

The grinding wheels are arranged at such an angle with relation to the cutter that the front edge of one wheel and the rear edge of the other wheel engage the cutter as they are pressed together, while the edges of the wheels are so rounded as to give the proper

cutting edge to said cutter, as best shown in Figs. 3 and 4. This arrangement permits the grinding device to be readily applied to or removed from the machine by simply unscrewing the nut n' and throwing the pivoted cover K upwardly. The slot k^2 permits the grinding wheels to be lowered to make up for the wear of the cutter while the handles r provide a ready means for placing an edge on the cutter at any time. Further, the wearing parts of the device are thoroughly protected from the dust of the grinding wheels; the said wheels being so secured to the disks O, O, that the same may be removed therefrom and others placed thereon when desired.

The foot-plate A is provided at suitable points with rollers S, having their bearings on the under side of said foot-plate. These rollers are so connected to the foot-plate as to be readily removed from said plate for the purpose of removing any dust that might and usually does collect around the rollers, thereby interfering with their proper working. As shown in Figs. 7 and 8, the shaft of the roller is journaled in boxes s, s , adapted to fit in apertures in the foot-plate; the said boxes being held in the plate by pivoted fingers s' , which when thrown in the position shown in the upper left-hand portion of Fig. 7, will permit the boxes and rollers to be removed at will.

The operation of the machine will be readily understood from the foregoing description.

It is obvious that the grinding device might be applied to other machines than the one referred to, and that it is not confined to be used in connection with rotary cutters.

In Fig. 9 I have shown a slight modification where instead of removing the boxes from the foot-plate, the shaft upon which the roller revolves is pivotally connected at s^3 to the under side of said foot-plate so that when the opposite end of said shaft is free the shaft may be turned on its pivot to remove any collection of dirt or dust.

In Fig. 10 the shaft of the grinding wheels is provided with a spline t on which are adapted to slide the tongues or keys t' , preferably removable, carried by said grinding wheels, and has surrounding said shaft a spiral spring t^2 located between the grinding wheels and by which they are normally pressed apart. The shaft p on which the depending arms R slide is also provided with a spring t^3 surrounding the same and abutting against the inner faces of said arms to serve as an auxiliary means for forcing the grinding wheels apart when they are released.

Instead of the pendent arms surrounding the shaft L, the lower portion may be forked so as to pass on opposite sides of the grinding wheel disks as shown in Fig. 10, or may otherwise engage same so as to move simultaneously with the movement of said arms.

I do not wish to confine myself to the exact construction shown and described as I may

modify same without departing from the character of my invention.

Having thus fully described my invention, what I claim as new, and desire to secure by Letters Patent of the United States, is—

1. In combination with the cutter, the yoke, the sleeves, and means for adjustably securing said sleeves to the yoke, the shaft passing through said sleeves, the grinding wheel disks normally pressed apart and arranged to slide upon the shaft, and arms slidingly held between the sleeves and provided with handles adapted to press said grinding disks together, substantially as described.
2. In a cloth-cutting machine, the combination with the foot-plate, the standard, the yoke or plate, the cutter and means for imparting motion to said cutter, of grinding wheels mounted upon a shaft, means for rotating said shaft, a sleeve or bearing supporting said shaft at one end and provided with means for removably connecting the sleeve or bearing to the yoke or plate, substantially as described.
3. The combination with the frame, the yoke, the cutter and support therefor and means for imparting motion to said cutter, of the sleeve and nuts arranged on the end thereof for securing same to said yoke, a shaft passing through the sleeve and means for rotating said shaft, grinding wheels slidingly held on the shaft, and means for normally pressing said grinding wheels apart, substantially as described.
4. In combination with the rotary cutter and the yoke or plate, the sleeve secured to said yoke so as to be radially adjustable thereon, a shaft passing through said sleeve, grinding wheels slidingly held on said shaft, together with means for holding the wheels normally apart, substantially as described.
5. The combination with the rotary cutter and the yoke or plate, of the sleeve passing through a slot in said yoke and secured to the yoke so as to be radially adjustable thereon, a dust guard arranged to cover the slot through which the sleeve passes, a shaft journaled in said sleeve, grinding wheels slidingly held on said shaft, together with means for

holding the wheels normally apart, substantially as described.

6. In combination with the cutter and the yoke or plate having a pivoted section or cover thereon, a sleeve passing through a slot in said yoke and cover and secured to the yoke so as to be radially adjustable thereon, a shaft journaled in said sleeve, grinding wheels slidingly held on said shaft, together with means for pressing the wheels in engagement with the cutter, substantially as described.

7. The combination with the frame, the cutter and the yoke or plate and means for imparting motion to the cutter, of the sleeve passing through a radial slot in said yoke, nuts arranged on the end of said sleeve on opposite sides of the yoke for adjustably securing same to said yoke, a shaft journaled in the sleeve, together with grinding wheels slidingly held on said shaft, substantially as described.

8. In a cloth-cutting machine, the combination with the foot-plate, the standard, the yoke, the rotary cutter and means for imparting motion to said cutter, of the grinding wheels mounted upon a shaft which extends obliquely to the axis of the cutter, means for imparting motion to said shaft, and a sleeve in which said shaft is journaled; the said sleeve having nuts for securing the same to the yoke in such manner as to be radially adjustable with relation to the cutter, substantially as described.

9. In combination with the rotary knife, the sleeves and means for securing same in the desired position, the shaft passing through the sleeves, collars secured to the shaft adjacent to and bearing against the sleeves, the said sleeves having projections fitting into annular grooves in the collars to provide a dust-proof joint, together with grinding wheels slidingly held on the shaft between the collars, substantially as described.

In testimony whereof I affix my signature in presence of two witnesses.

JOHN WOLF, JR.

Witnesses:

JOS. H. LITTELL,
DAVID WERTHEIM.