

T. SMART, Jr.

THIMBLE SKIN AND BOX FOR VEHICLES.

No. 109,066.

Patented Nov. 8, 1870.

Fig. 1.

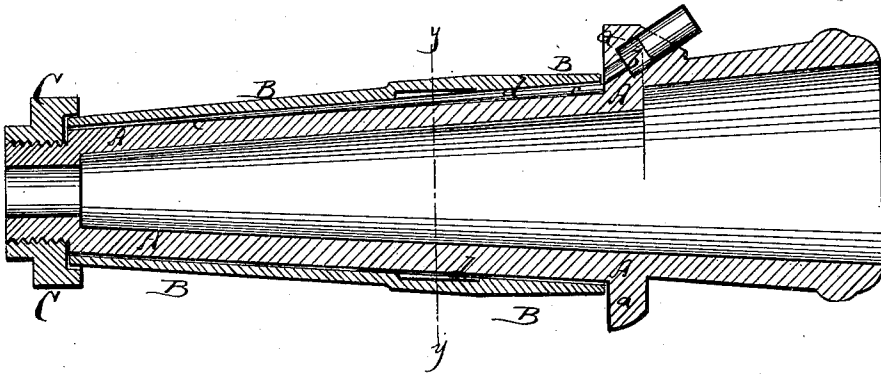
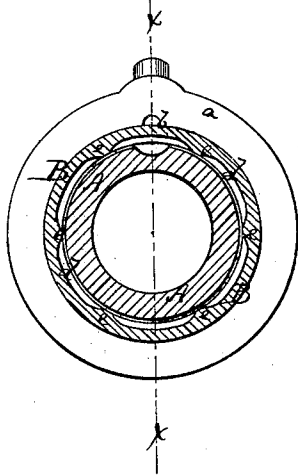

Fig. 2.



Witnesses:

E. Wall
L. S. Baker

Inventor:

T. Smart, Jr.
PER *M. M. C.*
Attorneys.

UNITED STATES PATENT OFFICE.

THOMAS SMART, JR., OF BROCKVILLE, CANADA, ASSIGNOR TO HIMSELF
AND EDWARD SMART, OF PITTSBURG, PENNSYLVANIA.

IMPROVEMENT IN THIMBLE-SKEINS AND BOXES FOR VEHICLES.

Specification forming part of Letters Patent No. 109,066, dated November 8, 1870.

To all whom it may concern:

Be it known that I, THOMAS SMART, JR., of Brockville, in the county of Leeds and Dominion of Canada, have invented a new and Improved Thimble-Skein and Box for Wheeled Vehicles; and I do hereby declare that the following is a full, clear, and exact description thereof, which will enable others skilled in the art to make and use the same, reference being had to the accompanying drawings, forming part of this specification, in which—

Figure 1 represents a longitudinal section of my improved thimble-skein, *x x*, Fig. 2, being the section-line. Fig. 2 is a vertical transverse section of the same, *y y*, Fig. 1, being the section-line.

Similar letters of reference indicate corresponding parts.

This invention relates to a new self-lubricating axle-box or thimble-skein for wheeled vehicles; and it consists in such a construction of the skein and box that the lubricating material will, by the box, be distributed transversely, and on the skein longitudinally, so as to be thereby brought in contact with every portion of the surface to be lubricated.

A in the drawings represents the thimble-skein fitted upon the end of a wooden or other axle.

B in the axle-box, held in the hub and revolving around the skein. The inner end of the box B abuts against a shoulder, *a*, of the skein, said shoulder having in its upper part an inclined aperture, *b*, leading from the back to a longitudinal groove, *c*, on the upper face of the skein. The aperture *b* is enlarged at its outer part to constitute a chamber or reservoir for the lubricating material. The

groove *c* extends from the shoulder *a* forward, and becomes gradually smaller toward the outer end in the same proportion as the diameter of the skein is reduced, so that the supply of lubricating material will thereby be properly regulated. The inner side of the box B contains a recess or enlarged chamber, *d*, around the superior parts of the skein, and in this recess are longitudinal ribs *e e*. The lubricating material is poured into the chamber *b*, which is then properly closed. From the chamber *b* it flows into the groove *c*, and along the same to the outer end. When the groove is filled, the material will overflow to lubricate the entire circumference of the skein. The oil is then collected at the bottom of the box and flows to the large end of the same, into the chamber *d*, where it is taken up by the ribs *e* and carried again into the groove, to be used over. In this manner the apparatus will be made self-lubricating without perceptible waste, as the front joint of the skein and box is closed by a flanged nut, C, which overlaps the end of the box, as is clearly shown in Fig. 1.

Having thus described my invention, I claim as new and desire to secure by Letters Patent—

The combination, with the ordinary oil-channel *c*, (in an axle-box,) of the transverse chamber *d* and longitudinal ribs *e*, passing therethrough, to take up the superfluous oil and gradually convey it to the end of hub for distribution, as described.

THOMAS SMART, JR.

Witnesses:

T. R. SHEFFIELD,
W. S. SENKLER.