

(19) World Intellectual Property Organization
International Bureau



(43) International Publication Date
27 July 2006 (27.07.2006)

PCT

(10) International Publication Number
WO 2006/077486 A1

- (51) **International Patent Classification:**
A61M 15/00 (2006.01) A61J 1/00 (2006.01)
A61M 11/00 (2006.01)
- (21) **International Application Number:**
PCT/IB2006/000084
- (22) **International Filing Date:** 19 January 2006 (19.01.2006)
- (25) **Filing Language:** English
- (26) **Publication Language:** English
- (30) **Priority Data:**
60/645,095 20 January 2005 (20.01.2005) US
60/671,220 14 April 2005 (14.04.2005) US
- (71) **Applicant (for all designated States except US):**
TRUDELL MEDICAL INTERNATIONAL [CA/CA];
725 Third Street, London, Ontario N5V 5G4 (CA).
- (72) **Inventors:** **LU, Winston;** 286 Bankside Drive, Kitchener, Ontario N2N 3J9 (CA). **MORTON, Robert;** 110 St. Bees Court, London, Ontario N6G 4C1 (CA). **PICKARD, Mark;** 98 Wintergarden Road, London, Ontario N5Y 5M3 (CA). **BALLES, Joaquim;** 2029 Whipoorwill Place, London, Ontario N6G 5L7 (CA).

- (81) **Designated States (unless otherwise indicated, for every kind of national protection available):** AE, AG, AL, AM, AT, AU, AZ, BA, BB, BG, BR, BW, BY, BZ, CA, CH, CN, CO, CR, CU, CZ, DE, DK, DM, DZ, EC, EE, EG, ES, FI, GB, GD, GE, GH, GM, HR, HU, ID, IL, IN, IS, JP, KE, KG, KM, KN, KP, KR, KZ, LC, LK, LR, LS, LT, LU, LV, LY, MA, MD, MG, MK, MN, MW, MX, MZ, NA, NG, NI, NO, NZ, OM, PG, PH, PL, PT, RO, RU, SC, SD, SE, SG, SK, SL, SM, SY, TJ, TM, TN, TR, TT, TZ, UA, UG, US, UZ, VC, VN, YU, ZA, ZM, ZW.
- (84) **Designated States (unless otherwise indicated, for every kind of regional protection available):** ARIPO (BW, GH, GM, KE, LS, MW, MZ, NA, SD, SL, SZ, TZ, UG, ZM, ZW), Eurasian (AM, AZ, BY, KG, KZ, MD, RU, TJ, TM), European (AT, BE, BG, CH, CY, CZ, DE, DK, EE, ES, FI, FR, GB, GR, HU, IE, IS, IT, LT, LU, LV, MC, NL, PL, PT, RO, SE, SI, SK, TR), OAPI (BF, BJ, CF, CG, CI, CM, GA, GN, GQ, GW, ML, MR, NE, SN, TD, TG).

Published:

- with international search report
- before the expiration of the time limit for amending the claims and to be republished in the event of receipt of amendments

For two-letter codes and other abbreviations, refer to the "Guidance Notes on Codes and Abbreviations" appearing at the beginning of each regular issue of the PCT Gazette.

(54) **Title:** DISPENSING DEVICE

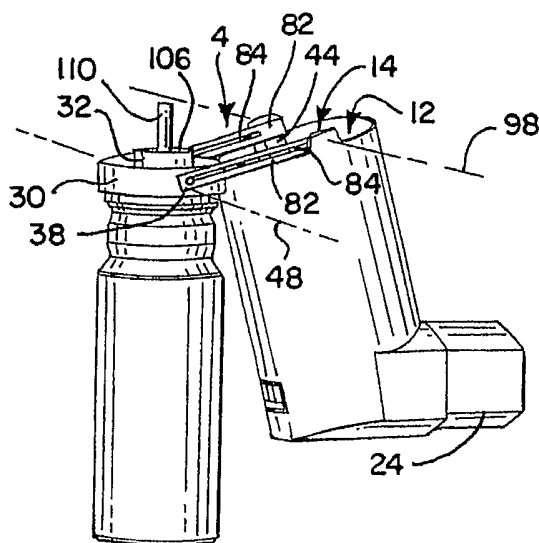

(57) **Abstract:** A dispenser includes a dispenser housing, an indicating device connected to the dispenser housing and a container removably engaged with the dispenser housing. A connector maintains a connection between the container and the dispenser housing as the container is moved between an engaged position and a disengaged position relative to the dispenser housing. In another aspect, a dispenser includes a dispenser housing, a key device adapted to be mounted to a container and an indicating device. The key device is moveable between an engaged position wherein it is engaged with the indicating device and a disengaged position wherein it is disengaged from the indicating device.

WO 2006/077486 A1

DISPENSING DEVICE

[0001] This application claims the benefit of U.S. Provisional Patent Application Serial Number 60/671,220, filed April 14, 2005 and entitled “Dispensing Device,” and U.S. Provisional Patent Application Serial Number
5 60/645,095, filed January 20, 2005 and entitled “Dispensing Device,” the entire disclosures of which are hereby incorporated herein by reference.

FIELD OF THE INVENTION

[0002] The present invention relates generally to a dispensing device, and in particular, to a dispensing device having a dosage indicator for indicating the
10 number of metered dosages that have been dispensed from, or remain in, a container that is associated with that particular dispensing device.

BACKGROUND

[0003] Aerosol dispensing devices have been developed that include a dose indicating device to indicate the number of metered doses that have been
15 dispensed from the device, or to indicate the number of doses remaining therein. For example, patients have certain conditions that can be treated with medicaments dispensed in an aerosol and administered to the patient by inhalation. In one format, the aerosol with medicaments are contained in a container, and dispensed in metered, or measured, dosages with an inhalation device, or actuator
20 boot. In such an arrangement, it can be important for the patient to be able to ascertain the number of metered doses remaining in the container, either by an indication of the number remaining therein or by knowledge of the number already dispensed therefrom, such that the patient is not caught unaware with an empty container when in need of the medicament. Thus, it may be important for the
25 inhalation device to provide an accurate indication of either the number of doses remaining in the container, or the number of doses already dispensed therefrom.

[0004] In addition, a particular actuator boot may be particularly suited or specially configured for dispensing a particular medicament from the container.

Therefore, it may also be important for the container and/or actuator boot to be configured to work with only a corresponding or associated actuator boot and/or container.

[0005] Typically, a conventional aerosol container includes a body and a valve stem that can be depressed relative to the body so as to emit the metered dose of aerosol and medicament. The container typically is supplied with a predetermined number of metered doses, generally on the order of about 200, such that the counting of the number of valve stem depressions, and corresponding number of dispensed metered doses, can be directly correlated with the number of doses remaining in the container.

[0006] In operation, the container is typically received within a housing of the inhalation device, wherein the valve is brought into engagement with a support block in the housing. The user administers the medicament by moving the container relative to the housing so as to depress the valve stem and internal valve and thereby release a metered dose, which is typically administered to the user through a port or mouthpiece extending from the housing. After the dose is administered, the valve stem, which is typically spring loaded, biases the container away from the support block so as to again move the container relative to the housing. In this way, a metered dose of medicament is administered by each cycle of linear reciprocal movement of the container relative to the housing.

[0007] Some actuator boots, or other devices attached to the medicament container, have indicating devices that convert the linear reciprocal movement of the container relative to the housing into a one-way, or single-cycle, movement of an indicator, wherein the indicator identifies the relative fullness of the container, the number of metered doses remaining therein or the number of doses already administered. Often, the indicator is disposed inside the actuator boot. If the container is removed from the actuator boot, for example to clean the actuator boot, a different container may inadvertently be inserted into the actuator boot, thereby corrupting the count or adversely affecting the ability of the actuator boot to properly dispense the substance.

[0008] To solve this problem, some devices, including the indicator, are secured to the container, as shown for example in U.S. Patent No. 6,431,168 to Rand. In the '168 patent to Rand, however, the indicators move with the container as it moves relative to the actuator boot. Therefore, the indicator member moves
5 relative to the viewing window in the actuator boot, which can be a distraction and can create confusion and difficulties in reading the device, thereby calling into question the accuracy and robustness of the device.

SUMMARY

[0009] Briefly stated, in one aspect the invention is directed to a dispenser that
10 dispenses dosages of a substance. The dispenser includes a container having an end portion and a valve stem extending from the end portion. A dispenser housing includes a top, a bottom and a longitudinally extending cavity defining an opening in the top. The bottom defines a well. An indicating device is connected to the dispenser housing and includes an indicator with dosage indicia. A connector
15 connects the dispenser housing and the container. The container is moveable between an engaged position, wherein the valve stem is disposed in the well and a disengaged position, wherein the valve stem is removed from the well. The connector maintains a connection between the container and the dispenser housing as the container is moved between the engaged and the disengaged positions.

20 [0010] In one embodiment, the connector includes a track and follower formed on one of a mounting portion mounted to the container and the dispenser housing. In one embodiment, the connector further includes an extension member connecting the mounting portion and the dispenser. The extension member can also include a track and/or one or more followers.

25 [0011] In an alternative embodiment, the connector includes a tether connecting the container and the dispenser housing. In one embodiment, the tether is made of a stretchable material.

[0012] In another aspect, the dispenser includes the dispenser housing, the indicating device and a connector having a mounting portion adapted to be
30 connected to the container. The connector is connected to the dispenser housing

with the mounting portion being moveable between a first position and a second position spaced from the first position.

[0013] In yet another aspect, a method for removing at least a portion of a container from a dispenser housing includes moving the container from an engaged position to a disengaged position and thereby removing the valve stem from the well. The connector maintains a connection between the container and the dispenser housing as the container is moved to the disengaged position.

[0014] In yet another aspect, a dispenser includes a dispenser housing, a key device and an indicating device. The key device has a mounting portion adapted to be connected to the container, and includes first and second rotatable rings. The indicating device is connected to the dispenser housing and includes an indicator having dosage indicia and first and second gears. One of the first ring and the first gear has a first key portion and the other of the first ring and the first gear has a first key passageway. Likewise, one of the second ring and the second gear has a second key portion and the other of the second ring and the second gear has a second key passageway. The key device is moveable between an engaged position wherein the first and second key portions are positioned in the first and second key passageways respectively and a disengaged position wherein the first and second key portions are removed from the first and second key passageways respectively.

[0015] In yet another aspect, the dispenser further includes the container, which has a canister and a valve stem. The valve stem is reciprocally moveable relative to the canister to release a dose of substance. The container is moveable between an engaged position wherein the first and second key portions are positioned in the first and second key passageways respectively and the valve stem is engaged with the dispenser housing, and a disengaged position wherein the first and second key portions are removed from said first and second key passageways respectively and the valve stem is removed from the well.

[0016] In yet another aspect, a method for operating a dispenser includes reciprocally moving the canister relative to the valve stem and dispensing a dosage of substance from the container upon each reciprocal movement of the canister.

The method further includes rotating the first gear a first incremental amount in response to each reciprocal movement of the canister, selectively engaging the second gear with the first gear upon a predetermined number of reciprocal movements of the canister, and rotating the second gear a second incremental amount with the first gear. The method further includes moving the container from an engaged position, wherein the first and second key portions are positioned in the first and second key passageways respectively and the valve stem is engaged with the dispenser housing, to a disengaged position, wherein the first and second key portions are removed from the first and second key passageways respectively and the valve stem is removed from the well.

[0017] The various embodiments provide simple, robust and inexpensive solutions for providing the user with information allowing them to ascertain the number of metered doses remaining in the container, either by an indication of the number remaining therein or by knowledge of the number already dispensed therefrom. In addition, in some of the embodiments, the container remains connected to the dispenser housing, even if it is removed therefrom, thereby ensuring that the integrity of the dose count for the container is preserved and also that the container will be used with a properly configured dispenser housing. Alternatively, other embodiments are configured such that a particular container can be associated only with a particular dispenser housing and indicating device by way of a key device connected to that container.

[0018] The foregoing paragraphs have been provided by way of general introduction, and are not intended to limit the scope of the following claims. The various preferred embodiments, together with further advantages, will be best understood by reference to the following detailed description taken in conjunction with the accompanying drawings.

BRIEF DESCRIPTION OF THE DRAWINGS

[0019] FIGURE 1 is a perspective view of a dispensing device including a dispensing housing with a viewing window revealing dosage indicia and a container positioned in an engaged position.

[0020] FIGURE 2 is a perspective view of the dispensing device shown in Figure 1 with the container in a first disengaged position.

[0021] FIGURE 3 is an exploded perspective view of the dispenser housing, container, indicating device and connector shown in Figure 1.

5 [0022] FIGURE 4 is a perspective view of the dispensing device shown in Figure 1 with the container in a second first disengaged position.

[0023] FIGURE 5 is a top perspective view of the dispensing device shown in Figure 4.

[0024] FIGURE 6 is a perspective view of one embodiment of a mounting member portion of a connector.

[0025] FIGURE 7 is a perspective view of one embodiment of an extension member.

[0026] FIGURE 8 is an exploded perspective view of an alternative embodiment of a connector with the dispenser housing shown in partial cross-section.

[0027] FIGURE 9 is an exploded perspective view of an alternative embodiment of a connector with the dispenser housing shown in partial cross-section.

[0028] FIGURE 10 is an exploded perspective view of an alternative embodiment of a connector with the dispenser housing shown in partial cross-section.

[0029] FIGURE 11 is a perspective view of a dispensing device including a dispensing housing, a container positioned in an engaged position and a hinged mouthpiece.

25 [0030] FIGURE 12 is a perspective view of the dispensing device shown in Figure 11 with the mouthpiece positioned in a cleaning position.

[0031] FIGURE 13 is a cross-sectional perspective view of the dispensing device shown in Figure 11.

[0032] FIGURE 14 is a perspective view of one embodiment of the mouthpiece.

30

- [0033] FIGURE 15 is a perspective view of one embodiment of the dispenser housing.
- [0034] FIGURE 16 is an exploded perspective view of an alternative embodiment of a dispensing device including a dispenser housing, a container, an
5 indicating device and a key device.
- [0035] FIGURE 17 is an enlarged, partial, perspective view of the indicating device and key device.
- [0036] FIGURE 18 is a bottom, exploded, perspective view of the indicating device, key device and container.
- 10 [0037] FIGURE 19 is a perspective view of one embodiment of a first gear of the indicating device.
- [0038] FIGURE 20 is a perspective view of one embodiment of a second gear of the indicating device.
- [0039] FIGURE 21 is a perspective view of one embodiment of a ring of the
15 key device.
- [0040] FIGURE 22 is a top perspective view of one embodiment of the indicating device without the first and second gears.
- [0041] FIGURE 23 is a partial, top perspective view of the indicating device shown in Figure 22 without a top cover member and first and second gears.
- 20 [0042] FIGURE 24 is a perspective view of an actuator member.
- [0043] FIGURE 25 is a side view of an alternative embodiment of a dispensing device with the container in a disengaged position.
- [0044] FIGURE 26 is a bottom perspective view of one embodiment of a tether cap member.
- 25 [0045] FIGURE 27 is a side view of another embodiment of a tether cap member.
- [0046] FIGURE 28 is a partial, cut-way view of another embodiment of a tether cap member.
- [0047] FIGURE 29 is a top perspective view of another embodiment of a tether
30 cap member.

- [0048] FIGURE 30 is a bottom perspective view of another embodiment of a tether cap member.
- [0049] FIGURE 31 is a side perspective view of another embodiment of a dispensing device with a cap member affixed thereto.
- 5 [0050] FIGURE 32 is a partial cross-sectional cut-away view of the dispensing device shown in Figure 31.
- [0051] FIGURE 33 is a side perspective view of another embodiment of a dispensing device.
- [0052] FIGURE 34 is a partial perspective view of the dispensing device
10 shown in Figure 33 with a top portion of the dispenser housing not shown.
- [0053] FIGURE 35 is a top perspective view of the bottom portion of the dispensing device shown in Figure 33.
- [0054] FIGURE 36 is a partial side cut-away view of the top portion of the dispenser housing shown in Figure 33.
- 15 [0055] FIGURE 37 is a cross-sectional side view of another embodiment of a dispensing device.
- [0056] FIGURE 38 is a top view of the dispensing device shown in Figure 37 with the container and connector not shown.
- [0057] FIGURE 39 is a top perspective view of the connector shown in Figure
20 37.
- [0058] FIGURE 40 is an exploded side view of a dispensing device.
- [0059] FIGURE 41 is a partial, cut-away view of the dispensing device shown in Figure 40 without the upper portion of the dispenser housing.
- [0060] FIGURE 42 is a partial, cut-away view of the dispensing device shown
25 in Figure 40 without the upper portion of the dispenser housing or the canister portion of the container.
- [0061] FIGURE 43 is a perspective view of the lower portion of the dispenser housing shown in Figure 40.
- [0062] FIGURE 44 is a perspective view of an alternative embodiment of a
30 dispenser housing lower portion.

[0063] FIGURE 45 a partial view of a dispensing device incorporating the lower portion of Figure 44 but without the upper portion of the dispenser housing or the canister portion of the container.

[0064] FIGURE 46 is a partial, cut-away view of a dispensing device
5 incorporating the lower portion shown in Figure 44.

[0065] FIGURE 47 is a partial, exploded perspective view of one embodiment of a dispensing device.

DETAILED DESCRIPTION OF THE PRESENTLY PREFERRED EMBODIMENTS

10 [0066] Referring to the drawings, and in particular FIGS. 1-5, a dispensing device, or dispenser, is shown as including a housing 10, or actuator boot, and a container 100 disposed therein. The housing has a longitudinally extending cavity 12 shaped to receive the container. A top portion of the housing is generally open such that the container can be inserted in the housing through opening 14 and be
15 installed therein with a bottom end 102 of the container protruding from the housing and exposed to the user for actuation.

[0067] The term "longitudinal" as used herein is intended to indicate the direction of the reciprocal movement of the container relative to the housing. The terms "top," "bottom," "upwardly" and "downwardly" are intended to indicate
20 directions when viewing the inhalation devices as shown in the Figures, but with the understanding that the container is inverted such that the top surface thereof is located adjacent the bottom of the housing and vice versa.

[0068] As shown in FIGS. 5, 13, 15, 41 and 46, a support block 16 having a well 18 is formed in a bottom portion 22 of the housing. An orifice 20 penetrates
25 the support block to communicate with a bottom portion of the well. Referring to FIGS. 2-4, a mouthpiece 24, intended for insertion into the mouth of a patient, forms an exhaust port 26 that communicates with the orifice and well. The mouthpiece 24 extends laterally from the housing so as to facilitate insertion of the mouthpiece into the mouth of the patient.

[0069] The container 100 is formed as a cylindrical canister 104 having a 106 hub disposed on a top surface 108 thereof. The container also has a shoulder 180 and a neck portion 188. A valve stem 110 extends longitudinally from the hub. The valve stem extends coaxially from the canister and is biased outwardly
5 therefrom by a spring (not shown) mounted within the canister. The container 100 is mounted in the housing by press fitting the valve stem 110 in the well 18 of the support block, which defines an "engaged" position of the container. The container is in a "disengaged" position when the valve stem 110 is removed from the well 18 of the support block.

10 [0070] It should be understood that the container can be configured in a variety of shapes and sizes, and that the substance contained therein can be released by any number of valve systems that are well known in the art. It should also be understood that the valve system can be actuated by a variety of actuators, including, but not limited to, various pumps, levers, actuator boots, buttons and the
15 like. In such embodiments, the valve system can be actuated by an actuator moveable relative to the container and housing such that the container remains stationary relative to the housing.

[0071] In a preferred embodiment, the container 100 is filled with a substance which is dispensed therefrom in specific metered doses by depressing or moving
20 the valve stem 110 from an extended closed position to a depressed open position, which in turn opens the valve or valve system. Preferably the substance is a medicament, although it should be understood that the container should be used to hold a variety of non-medicinal substances, including, but not limited to, various liquids, foams or aerosols. A single metered dose is dispensed from the container
25 by each reciprocal, longitudinal movement of the valve stem and attendant opening and closing of the valve.

[0072] In operation, the opening of the valve stem and valve is effected by moving the container 100 reciprocally within the housing 10 along a longitudinal axis, defined by the valve stem and the reciprocal movement of the container, by
30 depressing the exposed bottom end 102 of the canister relative to the housing 10 so as to move the valve stem 110 to the open position as it is supported within the

well by the support block. Alternatively, an actuator can be moved to open the valve system of the container, which can remain stationary with respect to a supporting housing, a cap and/or an indicating device mounted thereto. For example, the actuator can be attached to the end of the container in the form of a pump device or the like.

5 [0073] As the valve stem is moved to the open position, the container dispenses a metered dose of the substance in aerosol form through the well 18 and orifice 20 and into the exhaust port. The substance in aerosol form is then transmitted to the user through the exhaust port of the mouthpiece by way of either
10 a self-generated or assisted airflow. Alternatively, metered doses of liquids and the like can be dispensed from the container.

In other delivery systems, the housing and holder for the container are attached to a component having a chamber with an output end. Examples of these kinds of delivery systems are shown for example in U.S. Patent 5,012,803, issued
15 May 7, 1991, and U.S. Patent 4,460,412, issued September 11, 1984, the entire disclosures of which are hereby incorporated herein by reference. (No license, expressed or implied, is intended to be granted to either of these patents by reason of the incorporation by reference herein.) In these kinds of delivery systems, the component having the chamber can be adapted to receive the mouthpiece of the
20 housing, or it can be integrally connected with a holder supporting the container. In either embodiment, the metered dose of substance, preferably a medicament, in aerosol is first dispensed from the container into the chamber, and thereafter inhaled by the user.

[0074] In a preferred embodiment, the container 100 is intended to dispense a
25 predetermined number of metered doses of substance. For example, conventional inhaler containers typically hold on the order of 100 to 200 metered doses. In operation, it is important that the user be aware of the number of metered doses remaining in the container such that the user is not caught unaware with an empty canister when in need of the substance, such as a medicament.

30 [0075] Now referring to FIGS. 1-5, the dispenser is shown as including the housing 10, the container 100 mounted therein as described above and an indicator

assembly **2**. The indicator assembly can take many forms, as disclosed for example and without limitation in U.S. Patent Nos. 6,142,339, 6,161,724, 6,435,372 and 6,561,384, the entire disclosures of which are hereby incorporated herein by reference. The indicator assembly can include a single indicator member, or a plurality of (i.e., more than one) indicator members, shown for example as three co-axially mounted indicator members **50** in the various embodiments of FIGS. 1-4, 16, 22, 23, 32, 34, 37, 40, 41 and 46. In addition, the indicator assembly can be configured as a mechanical device or an electrical device, or a combination thereof, and can include without limitation various analog and digital readouts and indicia.

[0076] Referring to FIGS. 3, 17, 22, 32 and 37, an actuator member **70** is configured as a post member **72** moveably supported in the housing along an axis parallel to the longitudinal axis defined by the reciprocal movement of the container within the housing. A spring **88** is disposed around the post and biases the actuator member upwardly against the top surface **108** of the canister, or against a mounting portion secured thereto. Although a compression spring is shown in the Figures, it should be understood that cantilever, torsion, leaf and tension springs, and the like, would also work to bias the actuator member upwardly into engagement with the container. The springs can be made of metal or plastic.

[0077] In operation, the container is moved longitudinally within the housing so as to depress the valve stem to the open position and thereby open the valve as explained above. As the container is moved downwardly within the housing, the actuator member **70** is moved longitudinally downward. When the container is released by the user, the spring (not shown) within the container biases the container upwardly within the housing along the longitudinal axis such that the valve stem **110** is moved to the closed position within the container so as to close the valve, while the spring biases the actuator member upwardly. As the actuator is reciprocally moved, it selectively engages a ratchet gear **72**, which in turn operably moves one or more the indicator members upon a predetermined number of reciprocal movements.

[0078] The indicator members **50** are provided with indicia that are visible through one or more viewing windows **52**. The indicia indicate to the user the number of doses that remain in or have been dispensed from the container. In one embodiment, the indicia take the form of a color code, where, for example, a portion of the wheel is colored green to indicate the starting full position, a portion is colored yellow to indicate a medium fullness and a portion is colored red to indicate that the container is empty. Obviously, other colors, shading or alpha-numerical indicia can be provided on the indicator wheel to indicate the relative fullness or emptiness of the container.

10 [0079] In one embodiment, the indicator assembly includes three indicator members **50** coaxially mounted on an axle **56** and rotatable thereabout. Each of the indicator members is configured as an indicator wheel having a circumferential skirt with an outer circumferential surface **60** on which indicia (shown as numbers) are applied. In this embodiment, the ratchet gear **72** is coaxially mounted with the indicator wheel. The ratchet gear **72** includes a plurality of teeth formed around its periphery. In one embodiment, the ratchet gear is integrally molded with the indicator wheel, although it should be understood that the gear and wheel can be made separately and thereafter attached one to the other by welding, adhesive and the like.

15 [0080] In one embodiment, the first indicator member includes a resilient advancement member **62** that overlies the ratchet gear teeth of the second indicator member. Likewise, the second indicator member includes an advancement member that overlies the ratchet gear teeth of the third indicator member. It should be understood by one of skill in the art that one or more indicator members may be used to provide an indication of dosages used or available, and that the three indicator members shown in the Figures is meant to be illustrative, rather than limiting. In addition, it should be understood that a plurality of indicator members refers to any number of indicator members greater than one.

20 [0081] Referring to FIG. 38, a housing **10** is shown as having a pair of engagement members **64** formed integrally with the housing and including ramped surfaces. A plurality of non-return members **66** extend from the housing and

selectively engage the ratchet gear to ensure unidirectional rotation of the indicator member. Although the engagement members and non-return members are shown as being formed in or extending from a module housing, shown in FIGS. 3 and 16 and as described below, one of skill in the art should understand that those
5 members or equivalent features could also be formed in or connected to the dispenser housing or actuator boot that supports the container as shown in FIG. 34, 37 and 38 or disposed on or connected to the container itself.

[0082] In operation, the container is moved longitudinally within the housing **10** so as to depress the valve stem **110** to the open position so as to open the valve
10 as explained above. As the container is reciprocally moved within the housing, the actuator **70** engages the ratchet gear **72** secured to the first indicator member and rotates the first indicator member a predetermined angular or incremented amount corresponding to the pitch of the teeth disposed around the periphery of the ratchet gear.

[0083] The reciprocal movement of the container relative to the housing is
15 repeated until the first indicator member **50**, and its ratchet gear **72**, are rotated one complete revolution. The predetermined number of reciprocal movements required to advance the first indicator member one revolution is equal to the number of teeth disposed about the periphery of the ratchet gear **72**. As the first
20 indicator member is rotated by successive movements of the container relative to the housing, the advancement member **62** of the first indicator member is brought into selective engagement with the engagement member **64**, configured with the ramped surface formed in the housing. In particular, the engagement member **64** biases a tooth portion of the advancement member **62** into engagement with one of
25 the teeth of the ratchet gear **72** on the second indicator member.

[0084] As the first indicator member is further rotated by successive
movements of the container relative to the housing, whether it be the dispenser housing for the container or the module housing described below, the advancement member **62** engages one of the teeth on the ratchet gear **72** of the
30 adjacent (i.e., second) indicator member and advances the indicator member a predetermined incremental angular amount corresponding to the pitch of the

ratchet gear teeth. The term incremental is meant to refer to the angular amount the indicator member is moved by the advancement of one actuation, which corresponds to the movement of one tooth, regardless of whether the indicating device is indicating the number of doses left (e.g., counting down) or indicating the number of doses administered (e.g., counting up).

[0085] As the resilient advancement member **62** clears the engagement member **64**, it springs away from the ratchet gear such that further advancements of the first indicator member do not effect a rotation of the second indicator member until the first indicator member completes yet another cycle so as to again bring the advancement member into engagement with the next tooth of the second indicator member ratchet gear, and so on. The second indicator member with its advancement member similarly interacts with a second engagement member overlying the teeth of the third indicator member so as to selectively engage and advance the third indicator member a predetermined incremental amount for each complete rotation of the second indicator member. It should be understood that more indicator members could be similarly assembled to provide an incremental indicating device.

[0086] Referring to FIGS. 40, 41 and 46, a secondary or warning indicator member **300** is rotatably supported in the dispenser housing adjacent the indicator members about an axis parallel to and spaced apart from the axis of the indicator members **50**. The warning indicator **300** has an outer circumferential surface with warning dosage indicia applied thereto. Preferably, the warning dosage indicia takes the form of a color coding, for example a portion or zone of the surface is green, while another portion or zone is red. Preferably a plurality of zones is used, for example and without limitation two zones of green and red respectively, or three zones of green, yellow and red. Alternatively, alphanumeric characters, text messages etc. as herein described can be used as indicia. It should be understood that a surface of the indicator member perpendicular to the axis of rotation also can be configured with the indicia. The surface of the indicator member is visible through a viewing window **302** formed in the dispenser housing.

[0087] The second indicator member **300** further includes at least one driven member **306**, and preferably a plurality of driven members, configured in one embodiment as a teeth extending radially outward from the second indicator member on one side of the circumferential indicia surface. Taking into account
5 the spacing between the axes of rotation for the first and second indicator members **50**, **300**, a drive member coupled to one of the indicator members and the driven members are configured and have sufficient lengths so as to mesh after a predetermined number of rotations of the first indicator member **50** configured with the drive member. The second indicator member **300** is also provided with a
10 plurality of ratchet teeth **308** formed circumferentially around the axis of rotation on the side of the indicator member opposite the drive member. A non-return member extends from the dispenser housing or module housing and successively, selectively engages one or more of the ratchet teeth **308** so as to allow the second indicator member **300** to rotate in only one direction. Various embodiments
15 incorporating a warning indicator are further disclosed in U.S. Patent Application No. 10/968,815, filed October 18, 2004 and entitled Indicating Device With Warning Dosage Indicator, the entire disclosure of which is hereby incorporated herein by reference.

[0088] In a preferred embodiment of the dispenser, shown in FIGS. 3 and 16-
20 18, the indicator assembly is arranged in an indicator module **90**. The indicator module **90** is shaped to be received within the housing where it is disposed around a portion of the support block **16**. In particular, the support block is spaced apart from the wall of the dispenser housing, otherwise referred to as the actuator boot, so as to form a donut-shaped socket in the bottom of the housing. The module
25 includes a module housing **92** having an inner concave surface that is shaped to mate with an outer convex surface of the cylindrical support block and an outer convex surface that is shaped to mate with the inner concave surface of the housing which is also generally cylindrical. In this way, the module housing is shaped to be received within the socket formed around the support block.
30 Preferably, the module housing has a semicircular shape and fits around a portion of the support block opposite the orifice opening so as to not interfere with the

dispensing of the medicament, or the airflow transmitting the medicament to the patient. In this way, the module is maintained rearwardly of the midpoint of the support block. One of skill in the art should understand, however, that the module, or module housing, can be configured in any number of different sizes and shapes so as to be accommodated in a variety of housings or cap assemblies, with or without support blocks and the like. The module housing can be made of a single piece, or from two or more pieces joined to form the housing.

5 [0089] It should be understood, however, that the module can be secured within the housing by any number of conventional means, including the use of fasteners or adhesive. Alternatively, the module can simply be press fit into the socket formed between the support block and housing wall.

[0090] In various embodiments, as explained above, the indicia are applied to a circumferential surface 60 of the indicator wheel, for example in the form of numbers ranging from 0 to 9, with the ratchet gear on the indicator member having 10 teeth. In operation, it should be understood that the three, or more or less, indicator members can be preset to the maximum number of dosages contained within the container, with the indicia, or in this case numbers, arranged about the periphery of the indicator wheel, such that successive, sequential actuations of the container cause the indicator members to count down.

15 [0091] Alternatively, the indicator members are assembled such that the zero (0) of each indicator member is displayed in the viewing window to the user. The container is then actuated by the user such that the first indicator member rotates within the housing to sequentially display the number of doses that have been dispensed from 1 to 9. Upon the tenth actuation, the indicator member completes a single revolution, by virtue of the ten teeth preferably formed about the ratchet gear which correspond to the predetermined number of actuations, and causes the second indicator member to advance one number from 0 to 1 as the first indicator member again displays a 0 such that the two members together indicate that 10 dosages have been dispensed. The first indicator member is again rotated by successive actuations until another single rotation is completed to further rotate the second indicator to reveal the 2, so as to indicate that 20 dosages have been

dispensed. Upon a complete rotation of the second indicator member, corresponding to 100 actuations, the third indicator member is advanced to reveal a 1 in the viewing window with the first and second indicator members revealing a 0, and so on.

5 [0092] Although the indicator assembly embodiments of FIGS. 1-5, for example, are shown as being mounted in the indicator module, one of skill in the art should understand that the assembly, including the axle, indicator members, ratchet gears, actuator member and spring could be mounted directly in the dispenser housing or actuator boot that supports the container, as shown for
10 example in FIG. 34, 41 and 46. Similarly, the engagement member, or members, and non-return member, or members, could be formed in the dispenser housing that supports the container, otherwise referred to as the actuator boot, as shown in FIG. 38.

[0093] Referring to the embodiments of FIGS. 1-7, a connector 4 connects the
15 container and the dispenser housing, and maintains the connection therebetween as the container is moved between the engaged and disengaged positions. The term "connected" as used herein means that two or more members or components are coupled, whether directly or indirectly, for example with an intervening member or component. For example, it should be understood that the container is
20 connected to the dispenser housing when it is connected to the indicator assembly, which in turn is connected to the dispenser housing. The term "fixedly connected," or variations thereof, means that one component connected to another is not meant to be disconnected during the normal operation of the device and without undue force, while "releasably connected," means that one component is
25 meant to be disconnected during such normal operation and without undue force.

[0094] In one embodiment, the connector includes mounting portion 30
mounted to the container. The mounting portion, shown in FIG. 6, includes a locking ring or collar 32 that is engaged with the hub 106, for example by snap-fit, and an annular wall that surrounds the end portion of the container. The mounting
30 portion can include a longitudinal slit to allow the collar to be snap fit onto the container. The mounting portion includes a pair of follower members 34

extending from the annular wall on opposite sides thereof. Each follower member includes a stem **36** and cap portion **38**.

[0095] The connector further includes a pair of longitudinally extending guide portions **40** formed along an interior of the dispenser housing. Each guide defines a track **42**. The guides include a top portion **44** that extends longitudinally from the top of the dispenser housing. The track **42** terminates at an upper portion of the guide **44** to define a travel limiting stop **46**.

[0096] In one embodiment, shown in FIGS. 11-15, the follower members **34** formed on the mounting portion are directly mounted in the track **42**, with the head or cap portions **38** being retained by the guide **40**, such that the container can be translated relative to the guide in the track between the engaged and disengaged positions. At the uppermost position of the container relative to the dispenser housing, and depending on the length of the top portions **44** of the guide, the container can also be rotated relative to the dispenser housing about an axis **48** defined by the follower members so as to provide access to the interior of the dispenser housing **10**.

[0097] Alternatively, or in addition thereto, the mouthpiece **24** is rotatably connected to an upper portion **6** of the dispenser housing. In one embodiment, the upper portion, which also includes the support block **16**, includes a pair of axles **8** extending laterally outward from an exterior thereof. In addition, the housing includes a catch component **54** formed along a top of a mouthpiece opening **78**. The mouthpiece includes a pair of tabs **74** defining openings **76** or sockets shaped to receive the axles **8**. The mouthpiece further includes a catch component **58**, that releasably engages the catch component **54** on the upper housing portion to releasably secure the mouthpiece in a closed, operable dispenser condition. The mouthpiece can be rotated or pivoted about an axis **80** defined by the axles to a cleaning position, wherein the user is provided with access to the interior of the upper portion of the dispenser housing, including the support block.

[0098] In another embodiment, shown in FIGS. 1-7, the connector further includes a pair of extension members **82**. Each extension member has a follower member **86** protruding laterally therefrom and a longitudinal track **84**, having

terminal upper and lower ends **94**, **96** defining travel limiting stop portions. The follower members **34** on the mounting portion are mounted in the tracks **84** of the extension members respectively and translate relative thereto. In addition, the follower members **34** can be rotated about the axis **38** relative to the extension members. At the same time, the extension members **82** can be translated by moving the follower members **86** thereof in the tracks **42** formed in the dispenser housing. The extension members **82** can also be rotated relative to the dispenser housing, as shown in FIGS. 4 and 5, by rotating the extension members about an axis **98** defined by the follower members **86** thereof.

10 [0099] In operation, the container **100** is moved from the engaged to the disengaged position. As the container is translated out of the dispenser housing, as shown in FIG. 2, the container **100** translates relative to the extension member **82**, while the extension member translates relative to the dispenser housing **10** after the mounting portion follower members **34** are engaged with the top travel
15 limiting stop portion **96**. As the container is completely removed from the dispenser housing, the container **100** can be rotated relative to the dispenser housing **10** and the extension members **82**. Likewise, once the extension members are fully translated relative to the dispenser housing such that the follower members **86** are engaged with the upper travel limiting stop portion **46**, the
20 extension member **82** can also be rotated relative to the dispenser housing **10**. In this way, the container can be translated and rotated, or moved, so as to provide access to the cavity **12** of the dispenser housing, for example to clean the housing, while maintaining a connection between the container and the dispenser housing.

[00100] In an alternative embodiment, shown in FIG. 8, the mounting
25 portion **130** includes a wall portion that extends longitudinally along the side of the container. The mounting portion forms a pair of guides each having a track **132**. In turn, a pair of follower members **134** extend laterally inward from an interior surface of the dispenser housing and are engaged in the tracks. In operation, the container and mounting portion, which is attached to the container,
30 are translated relative to the follower members **134** and dispenser housing **10**. In one embodiment (not shown), the follower members are formed on an extension

portion of the dispenser housing that extends from the top thereof such that the container and mounting portion can also be rotated relative to the dispenser housing.

[00101] In another embodiment, shown in FIG. 10, the extension member **82** of FIG. 7 is incorporated into the embodiment of FIG. 8, but with the follower member **86** of the extension members engaged in the tracks **132** of the mounting portion and the follower members **134** of the dispenser housing engaged in the tracks **84** of the extension members. During operation, the container and mounting portion **130** can be translated and/or rotated relative to the extension members **82** while the extension members can be translated and rotated relative to the dispenser housing **10**.

[00102] In yet another embodiment shown in FIG. 9, the dispenser housing includes a pair of guides **40** each defining a track **42**. A pair of extension members **182** each include a pair of longitudinally spaced follower members **184**, **186** extending from opposite sides of the extension member on opposite ends thereof. The follower members **184**, **186** are engaged respectively with the tracks **132**, **42** formed on the mounting portion and dispenser housing to allow the container and mounting portion to be translated and rotated relative to the extension member and dispenser housing, and also to allow the extension member **182** to be translated and rotated relative to the dispenser housing **10**, such that the container can be completely removed from the dispenser housing, but remain connected thereto.

[00103] It should be understood that although a pair of extension members, tracks, guides, follower members etc. are shown, that one or more than two such members can also be used to connect the container and the dispenser housing.

[00104] The various embodiments of FIGS. 1-15 maintain the connection between the container **100** and dispenser housing **10** so as to avoid a count corruption of the indicating device relative to the container, but also permit the container to be moved to a disengaged position so as to allow the dispenser housing to be cleaned.

[00105] In another embodiment, shown in FIGS. 37-39, a mounting portion 112 includes a plurality (shown as three) longitudinally extending arms 114 each having a catch portion 120 formed on a free end thereof. A collar portion 116 of the mounting portion includes longitudinal slits 122, allowing the collar portion to be snap fitted around the neck 188 of the container.

[00106] The dispenser housing includes a corresponding plurality of guides 118 each defining an opening or track. The arms 114 are disposed through the guides 118 such that the catch portions 120 engage a bottom of the guides and prevent the container from being removed therefrom when moved to a disengaged position. Alternatively, the catch portions 120 engage the bottom of the guides 118 as the container is moved to the engaged condition and thereafter maintains the container in the engaged position, thereby precluding it from being moving to the disengaged position. The arms 114 move relative to the guides 118 as the container 100 is reciprocally moved relative to the support block 16. In this embodiment, the indicator assembly is mounted directly in the bottom of the dispenser housing, although it should be understood that a module housing could also be used.

[00107] For example, and referring to the embodiment of FIG. 47, the arms 114 and catch portions 120 are inserted through openings 91 formed in the top of a module housing 90 and defining guides. The catch portions 120 engage a bottom of the top wall of the housing and prevent the container from being disengaged from the module housing 90 when the container is moved to a disengaged position. Alternatively, the catch portions 120 engage the module housing 90 as the container is moved to the engaged condition and thereafter maintains the container in the engaged position, thereby precluding it from being moving to the disengaged position. The arms 114 move relative to the openings 91 and module housing 90 as the container 100 is reciprocally moved relative to the support block 16. The module housing 90 can be fixedly secured to the dispenser housing, for example by snap-fit engagement with one or more tabs 93 that engage, for example and without limitation, a front, vertical surface and a top surface of the

module housing **90**. The module housing can also be attached by friction fit, welding (e.g., sonic), with adhesives, or some combination of the above.

[00108] In this way, in some embodiments, the dispenser housing **10** does not need to be modified or otherwise altered from a configuration wherein a dose indicator is not used. Rather, the user simply secures the module housing **90** in the bottom of the dispenser housing **10**, for example with adhesives or friction fit, and thereafter secures the container **100** to the module housing **90**, for example with the arms **114**.

[00109] Referring to the embodiment of FIGS. 33-36, the indicating device is mounted in a bottom portion **124** of the dispenser housing, either directly or with a module housing. An upper portion **126** of the dispenser housing is connected to the bottom portion. It should be understood that the bottom and upper portions can be made as separate members, which are affixed to one another for example with mechanical fasteners (e.g., snap fit), adhesives, ultrasonic welding or the like. The upper portion includes a plurality of downwardly inclined lugs **128** or arms that snap fit around the container **100** as the neck of the container is slid past the lugs and as the valve stem **110** is inserted into the support block **16**, with the lugs engaging the shoulder **180** of the container. The lugs, or catch portions, can be spaced from the support block such that they maintain the container in an engaged position at all times, or they can be spaced upwardly such that the container can be moved to a disengaged position, but cannot be removed from the dispenser housing. The catch portions engage the ferrule portion of the container to prevent it from being disengaged from the dispenser housing, while allowing the container to move downwardly relative to the catch portions to dispense a dose of substance.

[00110] Referring to the embodiment of FIGS. 44-46, the lugs or arms **128**, i.e. catch portions, can be formed in the lower portion **124**, which can include an integrally formed mouthpiece, or can have a separate mouthpiece **24** rotatably or pivotally connected thereto. The lugs **128** function in the same way as described above, but in this embodiment permit the removal of the upper portion **126** of the dispenser housing, for example to permit cleaning of the device. One of the upper

or lower portions can be configured with a stepped in wall **214** and shoulder **216**, which receives the other portion by way of a friction fit. Alternatively, one or the other of the upper and lower portion can be provided with one or more bumps or protuberances to frictionally or snap-fittingly engage the other component.

5 **[00111]** Referring to FIGS. 40-43, the dispenser housing includes a lower or bottom portion **124**, an upper portion **126** and a mouthpiece **24** rotatably connected to the lower portion **124**. In another embodiment, the mouthpiece is formed integrally with the lower portion **124**. In one embodiment, the upper portion **126** is made of a clear plastic, or is otherwise see-through, such that the
10 user can view the container, for example to read a label or prescription applied thereto. The entirety of the upper portion can be made see-through, or it can be provided with a see-through viewing window permitting viewing of a portion of the container, with the remainder of the upper portion not being see-through. The see-through aspect of the upper portion can be important, for example, if the upper
15 portion and container are fixed to the lower portion such that they are not removeable therefrom, for example to permit viewing of the label affixed to the container. Of course, the lower portion and mouthpiece can also be made see-through.

[00112] In one embodiment, the upper portion **126** is removably attached to
20 the lower portion **124** to facilitate cleaning of the device. For example, one of the upper or lower portions can be configured with a stepped in wall **214** and shoulder **216**, which receives the other portion by way of a friction fit. Alternatively, one or the other of the upper and lower portion can be provided with one or more bumps or protuberances to frictionally or snap-fittingly engage the other component.

25 **[00113]** A locking ring **202** is secured in the lower portion, for example and without limitation by friction fit, snap fit, welding, adhesives and/or some combination thereof. The ring has a central opening **204** formed by a scalloped inner periphery **206** defined by a circular opening **208** having a plurality (shown as six) of semi-circular openings **210** spaced around the periphery of the circular
30 opening. The combination of openings forms a plurality (shown as six) of gripping tabs **212** or catch portions. The tabs **212** engage the container, and in

particular surround the neck **188** thereof, with a snap-fit, such that the container is maintained in an engaged position with the support block, but cannot be disengaged from the lower portion by way of the locking ring **202** engaging the shoulder **180** of the container. The circulatory openings **210** or cut-outs permit air flow past or through the ring during actuation of the container. It should be understood that more or less openings could be formed. Alternatively, the ring can be formed with a single, central circular opening to receive the container, with other openings formed through the ring and spaced from the central opening if necessary to permit air flow.

5
10 **[00114]** Referring to FIGS. 31 and 32, another embodiment of a dispensing device includes a cap member **136** formed from a resilient, flexible material, such as rubber. The cap is secured over the container once it is positioned in the engaged position. The cap can be fixedly secured to the dispenser housing with adhesives, fasteners and the like. The user actuates the container by pushing on the rubber cap, which deforms as the container moves longitudinally downward relative to the dispenser housing. The dispenser housing is provided with a plurality of vent holes **138** that allow air to escape when the cap member is depressed to actuate the container.

15
20 **[00115]** It should be understood that the embodiments of FIGS. 31-46 can be configured so as to maintain the container in the engaged position once it is installed in the dispenser housing, meaning that it cannot be moved to the disengaged position with the valve stem removed from the support block. In this way, a single container is associated with a corresponding indicating device such that the count of dosages cannot be corrupted by removing the container from the dispenser housing and using it with a different housing. At the same time, the mounting arrangement permits the container to reciprocally move in the longitudinal direction relative to the support block so as to allow dosages of substance to be dispensed.

25
30 **[00116]** Referring to FIGS. 25-30, another embodiment of a dispensing device includes a connector including a tether **140**. A cap member **142**, or other mounting portion, includes an anchor **144**. The cap member **142** is mounted to the

container, either fixedly or releasably. In one embodiment, shown in FIG. 26, the cap member 142 includes a plurality of interior radially extending ribs 148 that engage the end of the container with a friction fit. In another embodiment, shown in FIG. 27, the cap member 142 includes a plurality of resilient tabs or fingers 150, which act as engagement members to engage the container.

[00117] Referring to FIG. 28, the cap member 242 is formed in a disc shape, with a bottom of the cap being attached to the bottom of the container with adhesives, or other suitable attachment devices. On the top of the cap, an anchor 144 is provided for connection to one end of the tether 140.

10 [00118] Referring to FIG. 29, the cap member 242 has a key hole formed therein and defining an anchor, with the key hole including a slot 244 and a hole 246 formed in a bottom of the cap member. The tether 140 includes a knot or stop portion formed on an end thereof which extends through the hole 246 in an engaged configuration, while the tether lies in the slot and extends from the cap member through an opening 248 in the side thereof defined by the slot. The opposite end of tether is secured to an anchor on the dispenser housing as explained below.

[00119] Referring to FIG. 30, the cap member 142 includes a slot 244 opening to the side thereof at an opening 248 such that the tether lies in the slot between the cap member and the bottom of the container and extends through the slot. The cap member further includes a hole 246 configured to secure an enlarged end of the tether.

[00120] The dispenser housing includes an anchor 146, which can be located on the exterior or interior of the housing. In one embodiment, the tether is made of a stretchable material, such as an elastomeric material, e.g. rubber or silicone. In other embodiments, the tether is made of a non-extensible material, which may or may not be contained in a retraction mechanism that winds and stores the tether. Opposite ends of the tether 140 are secured to the anchors 144, 146.

[00121] In operation, the user moves the container 100 from an engaged position to a disengaged position, which can include removing the entire container from the dispenser housing, for example to clean the housing. At the same time,

the tether maintains the connection of the container with the dispenser housing such that the dosage count is not corrupted.

[00122] Referring to the embodiment of FIGS. 17-24, a dispenser device includes a dispenser housing **10**, a key device **152** and an indicating device **90**.

5 The key device **152** has a mounting portion **158** connected to the container, for example by snap fit to the hub or neck of the container. IN one embodiment, the mounting portion **158** includes a collar **32** as disclosed above with respect to FIG. 6.

[00123] Referring to FIGS. 17-24, the key device **152** further includes first
10 and second rotatable rings **154**, **156**, shown for example in FIG. 21, which are rotatably secured to the mounting portion with the first ring disposed circumferentially around the second ring. In one embodiment, the mounting portion includes an edge portion on the bottom thereof that supports the rings. Each ring **154**, **156** includes an opening **160**, **162**, or key passageway, formed in a
15 bottom surface thereof. In an alternative embodiment, one or both of the rings includes a key portion extending downwardly therefrom. The key portion can be configured as a triangular tab member for example and without limitation.

[00124] The indicating device is connected to the dispenser housing as explained above. The indicating device further includes first and second gears
20 **164**, **166** rotatably mounted to the top thereof, e.g. sit in the base housing, and are rotatable about the longitudinal axis. The first and second gears include first and second key portions **168**, **170** extending upwardly therefrom. It should be understood that one or both of the first and second gears could also be configured with a key passageway. The key portions **168**, **170** are disposed in the key
25 passageways **160**, **162** as the container is moved to an engaged position with the valve stem engaged with the dispenser housing. Initially, the key passageways and key portions are aligned, for example side by side. When the container is moved to the disengaged position, the first and second key portions are removed from said first and second key passageways respectively.

30 [00125] Each of the first and second gears **164**, **166** includes a plurality of gear teeth extending from a bottom thereof and arranged circumferentially around

the gears. The teeth of the outer, first gear 164 are engaged with a drive gear 172 rotatably mounted in the module housing, as shown in FIGS. 23. The drive gear is coaxially mounted with a ratchet gear 174. The actuator 70, shown in FIG. 24, includes a finger or tab member 176 that selectively engages the teeth of the ratchet gear 174 and rotates the gear an incremental amount upon each reciprocal movement of the actuator 70 and container 100. In turn, the drive gear 172 rotates with the ratchet gear 174 and thereby rotates the outer gear 164 an incremental amount. The key portion 168 engages the ring 154 in the key passageway 160 and moves the ring on the container mounting portion.

5 [00126] Upon one complete revolution of the outer gear 164, an advancement member 178 extending radially and circumferentially along the inside of the outer gear, is biased inwardly by an engagement member formed on the indicator housing 92 into engagement with one of the teeth formed on the inside gear 166 so as to advance the inside gear 166. The inside gear 166 in turn rotates the second ring 156 by way of engagement of the key portion 170 with the key passageway 162.

[00127] In operation, the user reciprocally moves the container 100 relative to the valve stem 110 and dispenses a dosage of substance from the container upon each reciprocal movement of the canister. The first gear 164 is rotated by the drive gear 172 a first incremental amount in response to each reciprocal movement of the canister, and selectively engages the second gear 166 with the first gear upon a predetermined number of reciprocal movements of the canister. The first gear rotates the second gear a second incremental amount. As the first and second gears, and corresponding first and second rings, are moved to different positions, they define a changing unique key pattern corresponding to the number of doses that have been dispensed. Accordingly, only a container that has had the same number of doses dispensed therefrom can be reengaged with the dispenser housing, since the key portions 168, 170 must mate with the key passageways 160, 162 before the valve stem can be engaged with the support block.

20 [00128] In one embodiment, the container 100 is configured with a unique indicia that matches a corresponding unique indicia located on the housing 10, the

indicating device or assembly, or a combination of the housing and indicating device. For example, the container and housing can be configured with a matching color or alpha numeric character, or a combination of both, such that the user is advised that a particular container is associated with a particular housing.

5 For example and without limitation, both the container and housing can be configured with a label having a particular color (e.g., red) and an alpha-numeric indicia, e.g., "B263." In this way, the user is advised that the container matches the dispenser and is assured that the count indication on the indicating device associated with that dispenser corresponds to that container. In this way, there is
10 additional assurance of the number of doses remaining in the container, or the number of doses already dispensed therefrom. This identification system can be used by itself, i.e. as a primary linking/identification tool, or as an auxiliary identification tool used in cooperation with the other embodiments and connector devices disclosed herein.

15 **[00129]** In one embodiment, each container and corresponding housing/indicating device is provided with a unique indicia that is not duplicative of indicia used with any other housing/indicating device. In another embodiment, the indicia may be reused after the passage of time, for example a certain time beyond the expiration of any particular lot of medicament, such that an infinite
20 number of indicia is not required. In yet another embodiment, containers and housings/indicating devices dispensed to a particular user are configured with unique indicia, for example by having the pharmacy or other retailer maintaining records and assigning new indicia to refills and new prescriptions so as to preserve the uniqueness relative to that particular user. In this embodiment, other users
25 may randomly be assigned the same indicia as the indicia used by a particular user, but the uniqueness is preserved for each user.

[00130] Although the present invention has been described with reference to preferred embodiments, those skilled in the art will recognize that changes may be made in form and detail without departing from the spirit and scope of the
30 invention. As such, it is intended that the foregoing detailed description be regarded as illustrative rather than limiting and that it is the appended claims,

including all equivalents thereof, which are intended to define the scope of the invention.

WHAT IS CLAIMED IS:

1. A dispenser that dispenses dosages of a substance comprising:
a container comprising an end portion and a valve stem extending from
said end portion;
5 a dispenser housing comprising a top, a bottom and a longitudinally
extending cavity defining an opening in said top, said bottom defining a well;
an indicating device connected to said dispenser housing, said indicating
device comprising an indicator comprising dosage indicia; and
a connector connecting said dispenser housing and said container;
10 wherein said container is moveable between an engaged position wherein
said valve stem is disposed in said well and a disengaged position wherein said
valve stem is removed from said well, and wherein said connector maintains a
connection between said container and said dispenser housing as said container is
moved between said engaged and said disengaged positions.
15
2. The dispenser of claim 3 wherein said connector comprises a
mounting portion mounted to said container, wherein said mounting portion is
connected to said dispenser housing.
- 20 3. The dispenser of claim 2 wherein said mounting portion comprises a
collar engaging said end portion of said container.
4. The dispenser of claim 2 wherein one of said dispenser housing and
said mounting portion comprises at least one longitudinally extending guide, and
25 wherein the other of said dispenser housing and said mounting portion is
moveably connected to said guide and is moveable relative to said guide as said
container is moved between said engaged and said disengaged positions.
5. The dispenser of claim 4 wherein said guide comprises a track.

6. The dispenser of claim 5 wherein said one of said dispenser housing and said mounting portion comprises a follower member movably disposed in said track.

5 7. The dispenser of claim 6 wherein said dispenser housing further comprises a mouthpiece pivotally connected to said bottom of said container, wherein said mouthpiece is pivotable between a dispenser position and a cleaning position.

10 8. The dispenser of claim 5 wherein said connector further comprises an extension member connecting said mounting portion and said dispenser housing.

15 9. The dispenser of claim 8 wherein said extension member is pivotally connected to said mounting portion and to said dispenser housing.

10. The dispenser of claim 9 wherein said extension member comprises at least one follower engaging said track.

20 11. The dispenser of claim 10 wherein said track comprises a first track and said at least one follower comprises a first follower, and wherein said extension member further comprises a second track, and wherein said other of said mounting portion and said dispenser housing comprises a second follower engaging said second track.

25 12. The dispenser of claim 10 wherein said wherein said track comprises a first track and said at least one follower comprises a first follower, and wherein said extension member further comprises a second follower, and wherein said other of said mounting portion and said dispenser housing comprises
30 a second track, said second follower engaging said second track.

13. The dispenser of claim 1 wherein said connector comprises a tether.

14. The dispenser of claim 13 wherein said tether is made of a stretchable material.

5

15. The dispenser of claim 13 further comprising a first anchor secured to said container and a second anchor secured to said dispenser housing, wherein said tether is connected between said first and second anchors.

10 16. The dispenser of claim 15 wherein said first anchor comprises a cap member connected to said container.

17. The dispenser of claim 1 wherein an entirety of said container is moved through said opening in said top and is disposed outside of said cavity when in said disengaged position.

15

18. The dispenser of claim 1 wherein at least a portion of said container remains disposed in said cavity when in said disengaged position.

20 19. The dispenser of claim 1 wherein said indicating device is fixedly secured to said dispenser housing.

20. A dispenser that dispenses dosages of a substance from a container, the dispenser comprising:

25 a dispenser housing comprising a top, a bottom and a longitudinally extending cavity defining an opening in said top, said bottom defining a well;

an indicating device connected to said dispenser housing, said indicating device comprising an indicator comprising dosage indicia; and

30 a connector having a mounting portion adapted to be connected to the container, said connector connected to said dispenser housing wherein said

mounting portion is moveable between a first position and a second position spaced from said first position.

21. The dispenser of claim 20 wherein said mounting portion comprises
5 a collar.

22. The dispenser of claim 20 wherein one of said dispenser housing
and said mounting portion comprises at least one longitudinally extending guide,
and wherein the other of said dispenser housing and said mounting portion is
10 moveably connected to said guide and is moveable relative to said guide as said
mounting portion is moved between said first and second positions.

23. The dispenser of claim 22 wherein said guide comprises a track.

15 24. The dispenser of claim 23 wherein said one of said dispenser
housing and said mounting portion comprises a follower member movably
disposed in said track.

25 25. The dispenser of claim 24 wherein said dispenser housing further
comprises a mouthpiece pivotally connected to said bottom of said container,
wherein said mouthpiece is pivotable between a dispenser position and a cleaning
position.

26. The dispenser of claim 23 wherein said connector further comprises
25 an extension member connecting said mounting portion and said dispenser
housing.

27. The dispenser of claim 26 wherein said extension member is
pivotally connected to said mounting portion and to said dispenser housing.
30

28. The dispenser of claim 27 wherein said extension member comprises at least one follower engaging said track.

5 29. The dispenser of claim 28 wherein said track comprises a first track and said at least one follower comprises a first follower, and wherein said extension member further comprises a second track, and wherein said other of said mounting portion and said dispenser housing comprises a second follower engaging said second track.

10 30. The dispenser of claim 28 wherein said wherein said track comprises a first track and said at least one follower comprises a first follower, and wherein said extension member further comprises a second follower, and wherein said other of said mounting portion and said dispenser housing comprises a second track, said second follower engaging said second track.

15

31. The dispenser of claim 20 wherein said connector comprises a tether connected to said mounting portion.

20 32. The dispenser of claim 31 wherein said tether is made of a stretchable material.

33. The dispenser of claim 31 wherein said mounting portion comprises a cap member.

25 34. A method for removing at least a portion of a container from a dispenser housing, the method comprising:

providing said dispenser housing comprising a top, a bottom and a longitudinally extending cavity defining an opening in said top, said bottom defining a well; a container comprising an end portion and a valve stem extending
30 from said end portion and defining a longitudinal axis, said end portion disposed in said well wherein said container is in an engaged position; an indicating device

connected to said dispenser housing, said indicating device comprising an indicator comprising dosage indicia; and a connector connecting said dispenser housing and said container;

5 moving said container in said cavity from said engaged position to a disengaged position and thereby removing said valve stem from said well, wherein said connector maintains a connection between said container and said dispenser housing as said container is moved to said disengaged position.

10 35. The method of claim 34 wherein said moving said container to said disengaged position comprises maintaining at least a portion of said container in said cavity.

15 36. The method of claim 34 wherein said moving said container to said disengaged position comprises moving an entirety of said container through said opening in said top and disposing said entirety of said container outside of said cavity.

20 37. The method of claim 34 wherein said moving said container to said disengaged position comprises moving said container in a direction along said longitudinal axis.

25 38. The method of claim 37 wherein said moving said container further comprises pivoting said container about a pivot axis oriented substantially perpendicular to said longitudinal axis.

39. The method of claim 38 wherein said pivot axis is disposed outside of said cavity.

30 40. The method of claim 38 wherein said connector comprises an extension member connecting said container and said dispenser housing, wherein

said pivoting said container about said pivot axis comprises pivoting said container relative to said extension member about said pivot axis.

41. The method of claim 40 wherein said pivot axis comprises a first
5 pivot axis, and wherein said moving said container further comprises pivoting said extension member relative to said dispenser housing about a second pivot axis.

42. The method of claim 34 wherein said connector comprises a tether,
and wherein said moving said container to said disengaged position comprises
10 stretching said tether.

43. A dispenser that dispenses dosages of a substance from a container,
the dispenser comprising:

a dispenser housing;
15 a key device having a mounting portion adapted to be connected to the container, said key device comprising first and second rotatable rings; and
an indicating device connected to said dispenser housing, said indicating device comprising an indicator comprising dosage indicia and first and second
gears;

20 wherein one of said first ring and said first gear has a first key portion and the other of said first ring and said first gear has a first key passageway, and wherein one of said second ring and said second gear has a second key portion and the other of said second ring and said second gear has a second key passageway;

25 wherein said key device is moveable between an engaged position wherein said first and second key portions are positioned in said first and second key passageways respectively and a disengaged position wherein said first and second key portions are removed from said first and second key passageways respectively.

30 44. The dispenser of claim 43 wherein said second gear is selectively engaged by said first gear as said first gear is rotated relative to said second gear.

45. The dispenser of claim 44 wherein said second gear comprises a plurality of teeth and wherein said first gear selectively engages one of said teeth of said second gear upon each complete rotation of said first gear.

5

46. The dispenser of claim 45 wherein one of said first and second gears comprises an advancement member and further comprising an engagement member biasing said advancement member into selective engagement with said other of said first and second gears.

10

47. The dispenser of claim 43 further comprising a drive gear engaged with said first gear.

48. The dispenser of claim 47 further comprising a ratchet gear coaxially mounted with said drive gear and an actuator member selectively engaged with said ratchet gear.

15

49. The dispenser of claim 43 wherein first gear and said first ring are rotated at a first rate and said second gear and said second ring are rotated at a second rate, wherein said first rate is different than said second rate.

20

50. A dispenser that dispenses dosages of a substance from a container, the dispenser comprising:

a dispenser housing;

25

a container comprising a canister and a valve stem, said valve stem reciprocally moveable relative to said canister to release a dose of substance;

a key device mounted to said canister, said key device comprising first and second rotatable rings; and

30

an indicating device connected to said dispenser housing, said indicating device comprising an indicator comprising dosage indicia and first and second gears;

wherein one of said first ring and said first gear has a first key portion and the other of said first ring and said first gear has a first key passageway, and wherein one of said second ring and said second gear has a second key portion and the other of said second ring and said second gear has a second key passageway;

5 wherein said container is moveable between an engaged position wherein said first and second key portions are positioned in said first and second key passageways respectively and said valve stem is engaged with said dispenser housing, and a disengaged position wherein said first and second key portions are removed from said first and second key passageways respectively and said valve stem is removed from said well.

51. A method for operating a dispenser comprising:

 providing said dispenser housing and said container, said container comprising a canister and a valve stem, said valve stem reciprocally moveable
15 relative to said canister to release a dose of substance; a key device mounted to said canister, said key device comprising first and second rotatable rings; and an indicating device connected to said dispenser housing, said indicating device comprising an indicator comprising dosage indicia and first and second gears;
 wherein one of said first ring and said first gear has a first key portion and the
20 other of said first ring and said first gear has a first key passageway, and wherein one of said second ring and said second gear has a second key portion and the other of said second ring and said second gear has a second key passageway;

 reciprocally moving said canister relative to said valve stem;

 dispensing a dosage of substance from said container upon each reciprocal
25 movement of said canister;

 rotating said first gear a first incremental amount in response to each reciprocal movement of said canister;

 selectively engaging said second gear with said first gear upon a predetermined number of reciprocal movements of said canister;

30 rotating said second gear a second incremental amount with said first gear;
 and

moving said container from an engaged position, wherein said first and second key portions are positioned in said first and second key passageways respectively and said valve stem is engaged with said dispenser housing, to a disengaged position, wherein said first and second key portions are removed from said first and second key passageways respectively and said valve stem is removed from said well.

52. The method of claim 51 wherein said predetermined number of reciprocal movements is greater than one.

10

53. A dispenser that dispenses dosages of a substance from a container, the dispenser comprising:

a dispenser housing having a top defining an opening;

15 a container with a valve stem engaged with the dispenser housing and an end extending through said opening; and

a resilient, flexible cap fixedly secured to said dispenser housing, said cap covering said container and said opening and preventing said valve stem from being disengaged from said dispenser housing.

20 54. A dispenser that dispenses dosages of a substance from a container, the dispenser comprising:

a dispenser housing having at least one guide;

25 a container with a valve stem engaged with the dispenser housing, said container moveable relative to said valve stem between at least a first and second position; and

a connector comprising at least one arm having a catch portion, said arm disposed through said at least one guide with said catch portion engaged with said guide such that said valve stem is prevented from being disengaged from said dispenser housing, wherein said at least one arm is moveable relative to said guide as said container is moved between said first and second position.

30

55. The dispenser of claim 54 wherein said connector is connected to said container.

56. The dispenser of claim 55 wherein said connector comprises a collar
5 engaging said container.

57. The dispenser of claim 54 wherein said dispenser housing comprises a module housing and an indicator disposed in said module housing, wherein said at least one guide is formed in said module housing.

10

58. A dispenser that dispenses dosages of a substance from a container, the dispenser comprising:

a dispenser housing having at least one catch portion;

)
a container with a valve stem engaged with the dispenser housing and
15 comprising a neck and a ferrule portion, wherein said container is moveable relative to said valve stem between at least a first and second position, wherein said catch portion engages said ferrule portion such said valve stem is prevented from being disengaged from said dispenser housing, and wherein said container is moveable relative to said catch portion as said container is moved between said
20 first and second position.

59. The dispenser of claim 58 wherein said dispenser housing comprises a lower portion and an upper portion.

25 60. The dispenser of claim 59 wherein at least said upper portion is at least partially see-through.

61. The dispenser of claim 59 wherein said at least one catch member is connected to said lower portion.

30

62. The dispenser of claim 61 wherein said lower portion is removably attached to said upper portion.

63. The dispenser of claim 58 comprising a locking ring connected to said dispenser housing, wherein said locking ring comprises said at least one catch
5 portion.

64. The dispenser of claim 63 wherein said locking ring defines at least one central opening shaped to receive said neck and at least one circulatory
10 opening operable to permit air flow past said locking ring.

FIG. 1

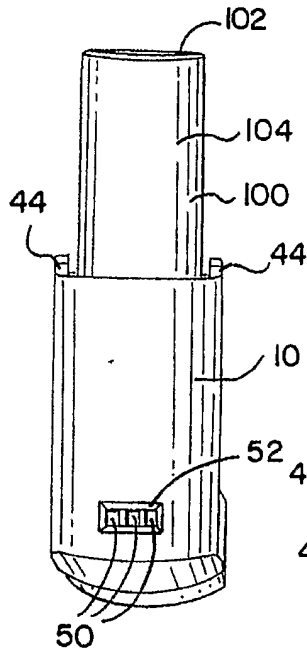

FIG. 2

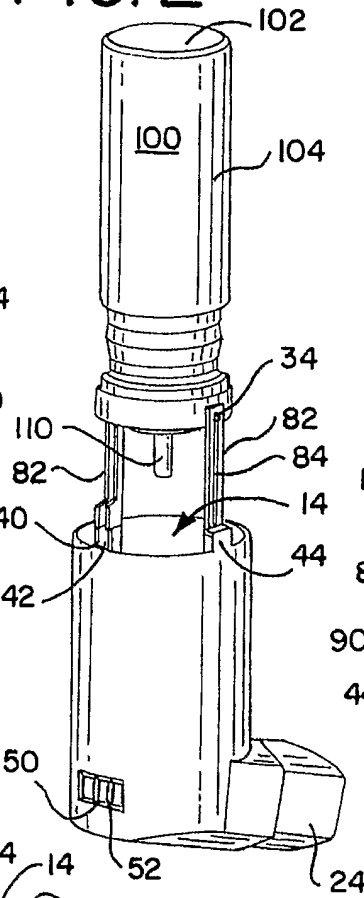

FIG. 3

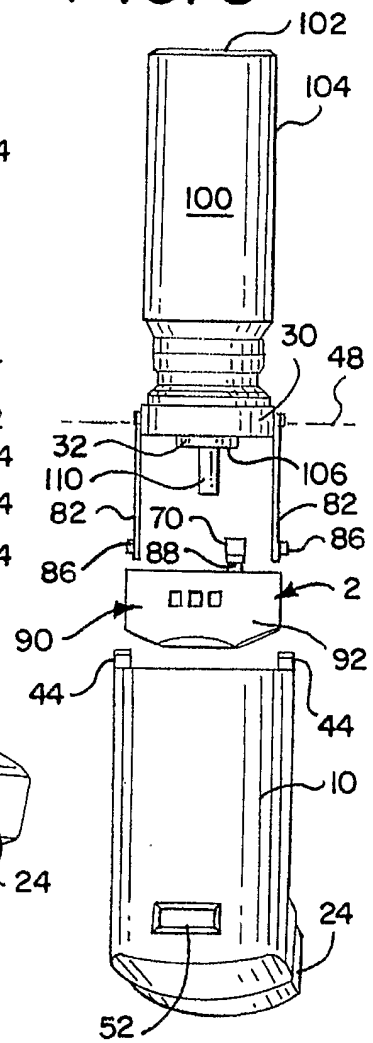

FIG. 4

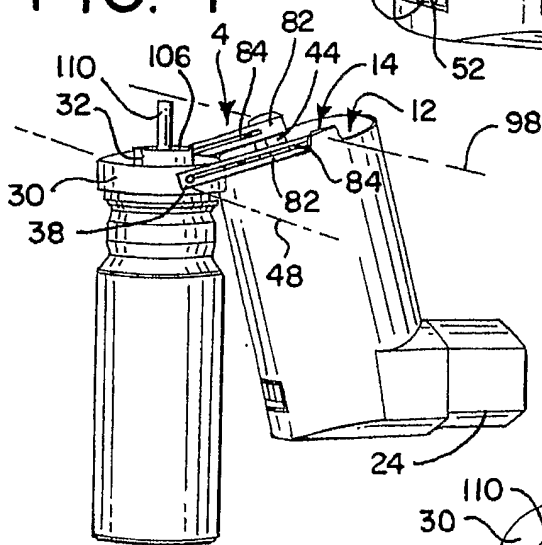
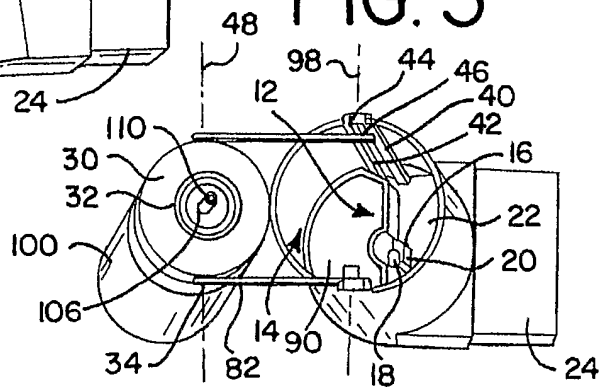

FIG. 5



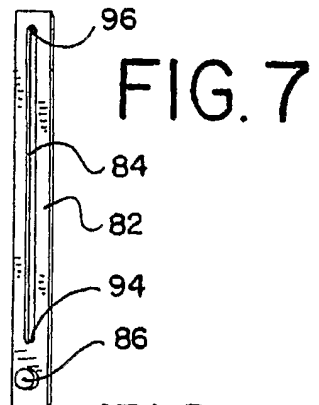

FIG. 7

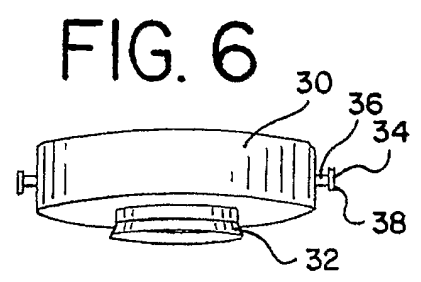

FIG. 6

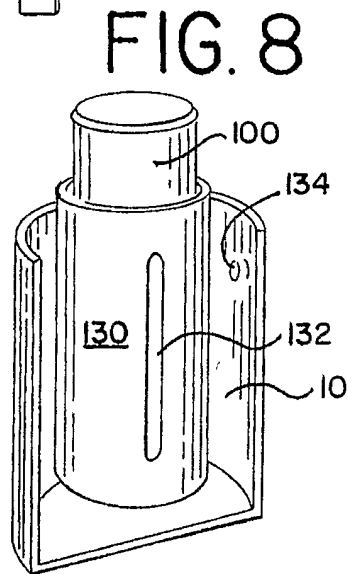

FIG. 8

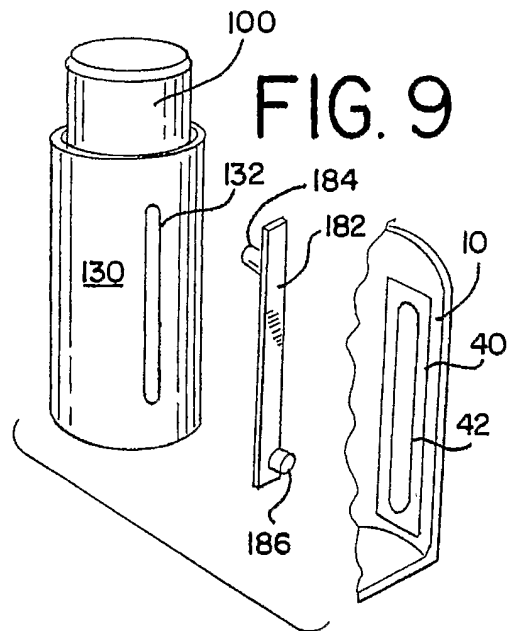

FIG. 9

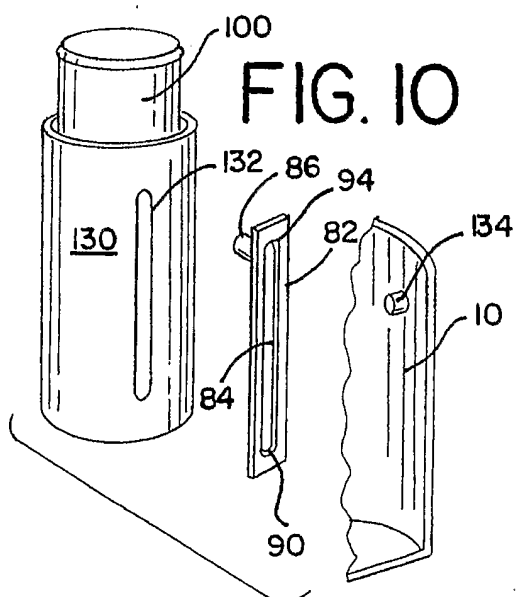

FIG. 10

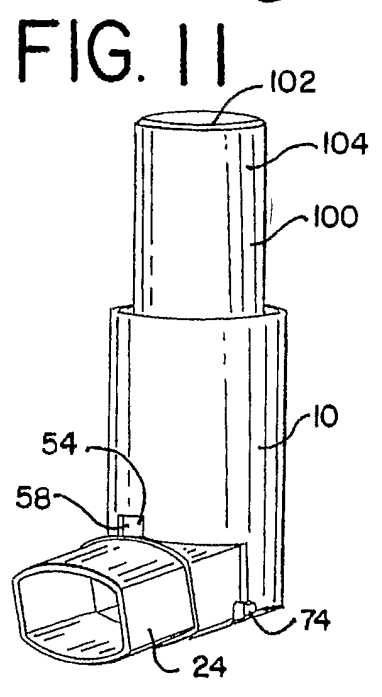

FIG. 11

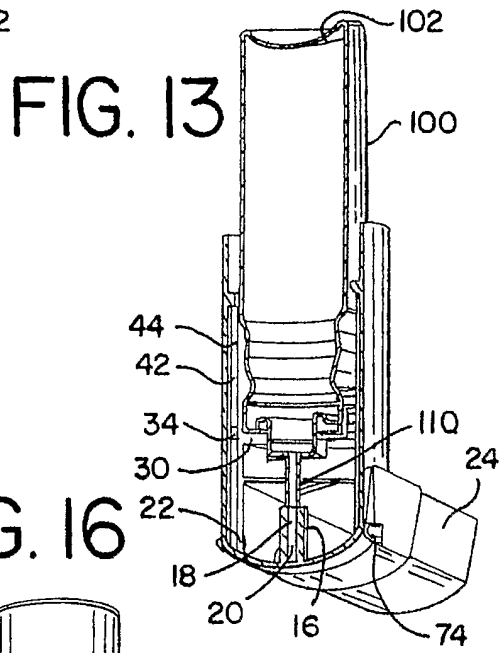
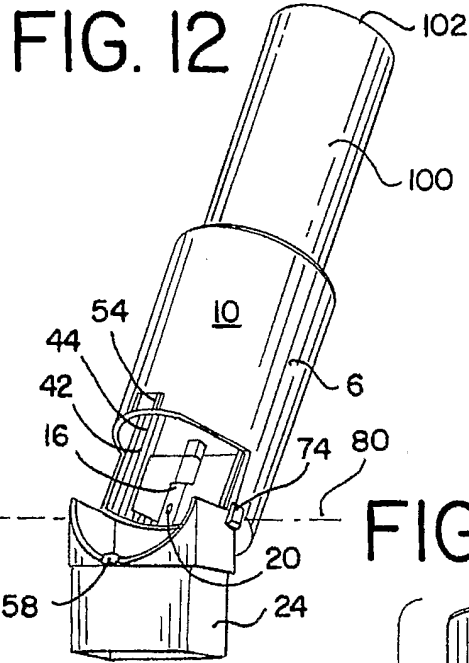

FIG. 16

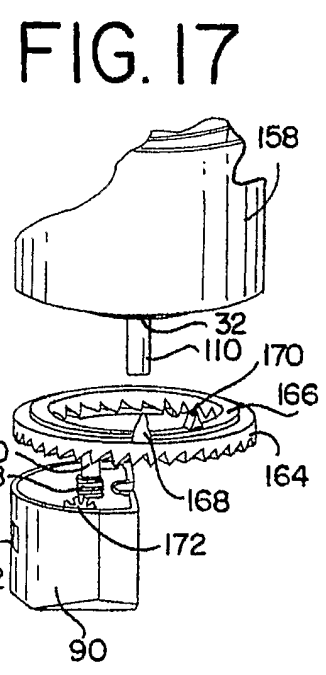
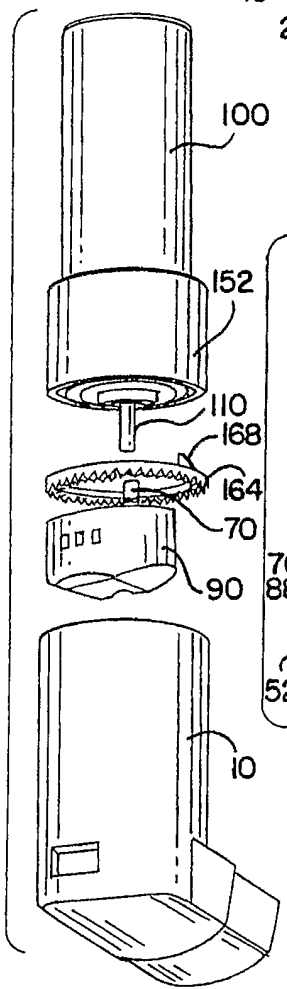
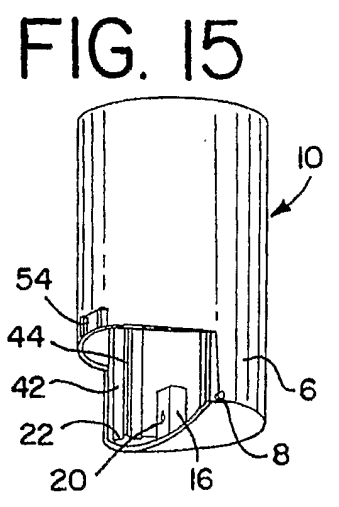
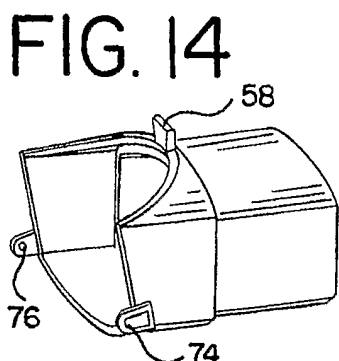

FIG. 18

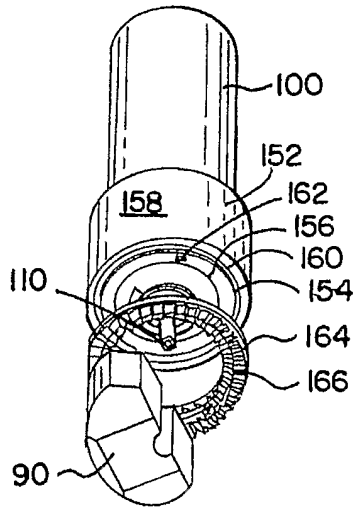

FIG. 19

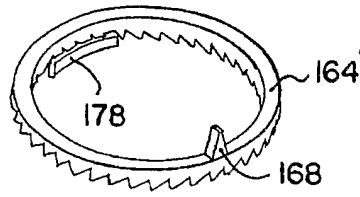

FIG. 20

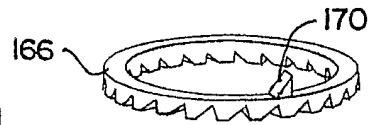

FIG. 21

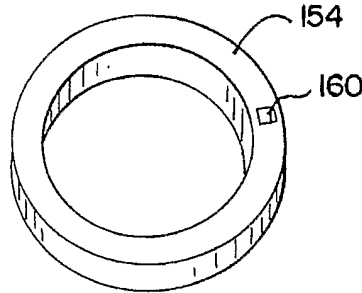

FIG. 22

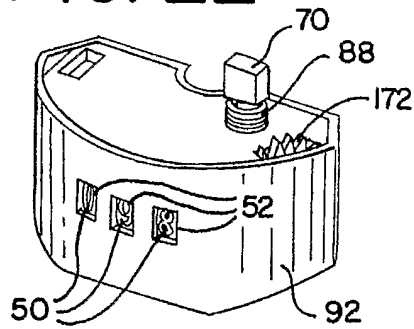

FIG. 23

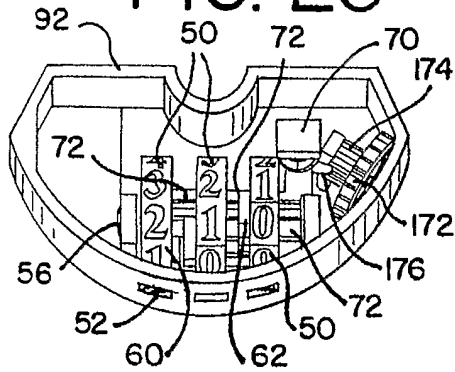

FIG. 24

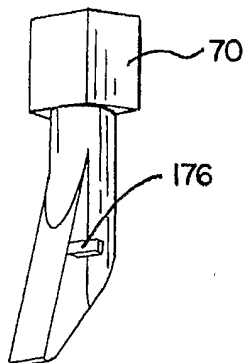
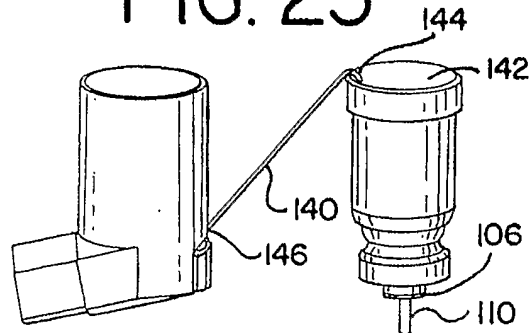

FIG. 25



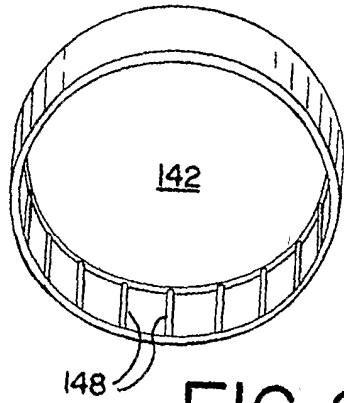

FIG. 26

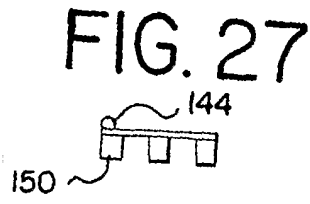

FIG. 27

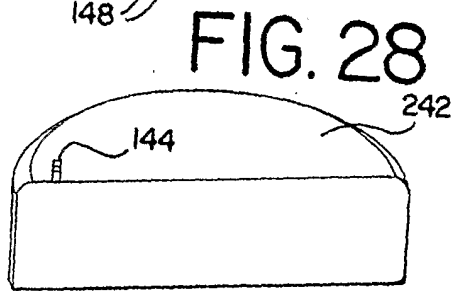

FIG. 28

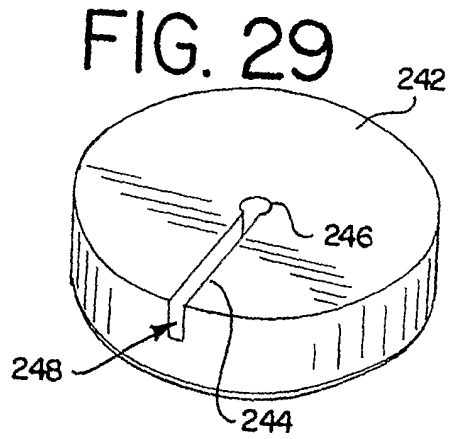

FIG. 29

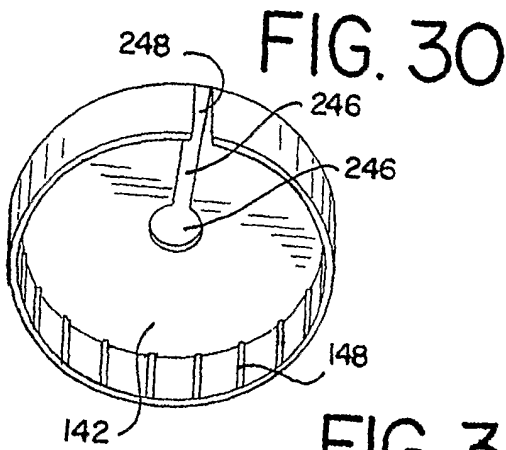

FIG. 30

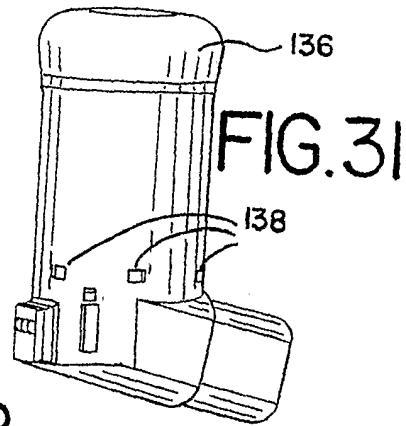

FIG. 31

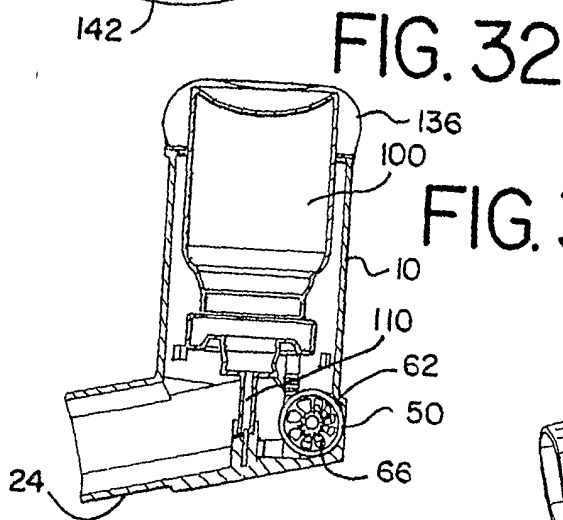

FIG. 32

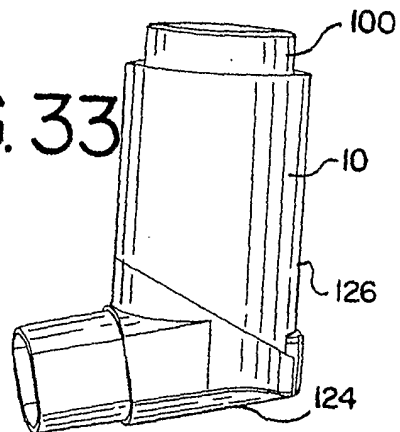

FIG. 33

FIG. 34

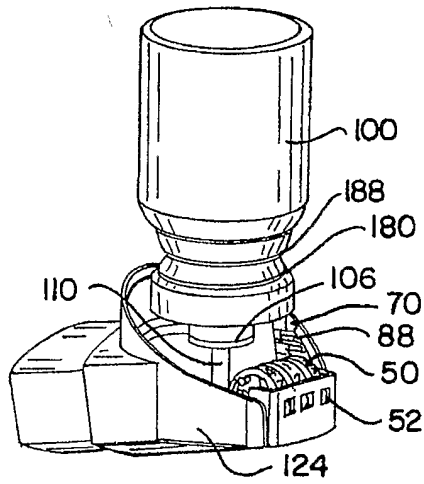

FIG. 35

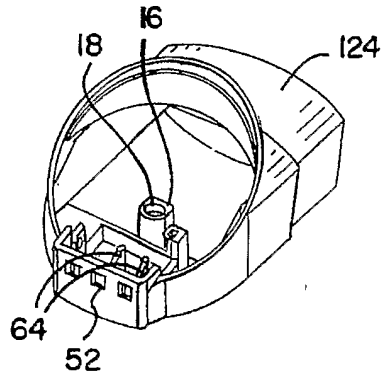

FIG. 37

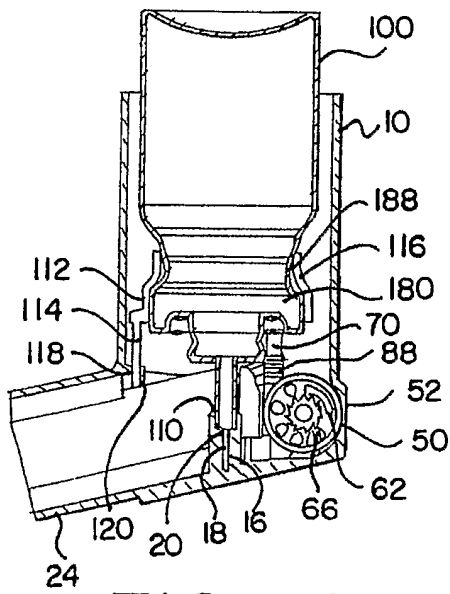

FIG. 36

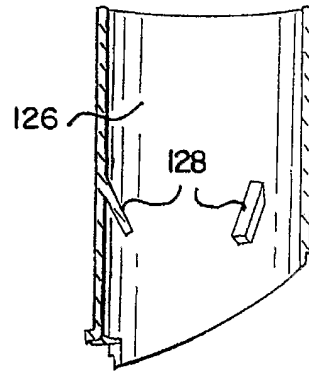

FIG. 39

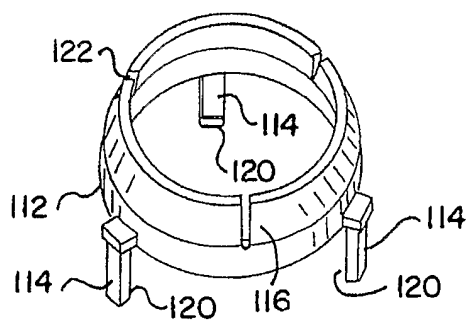
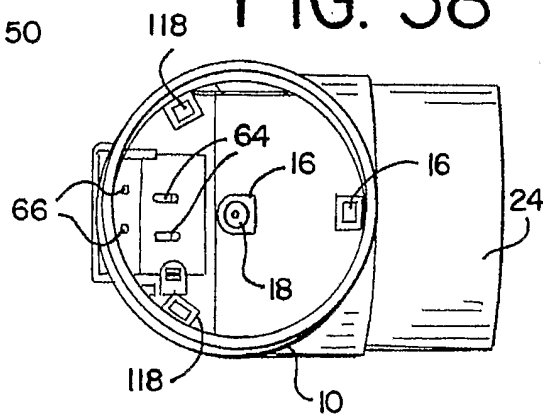

FIG. 38



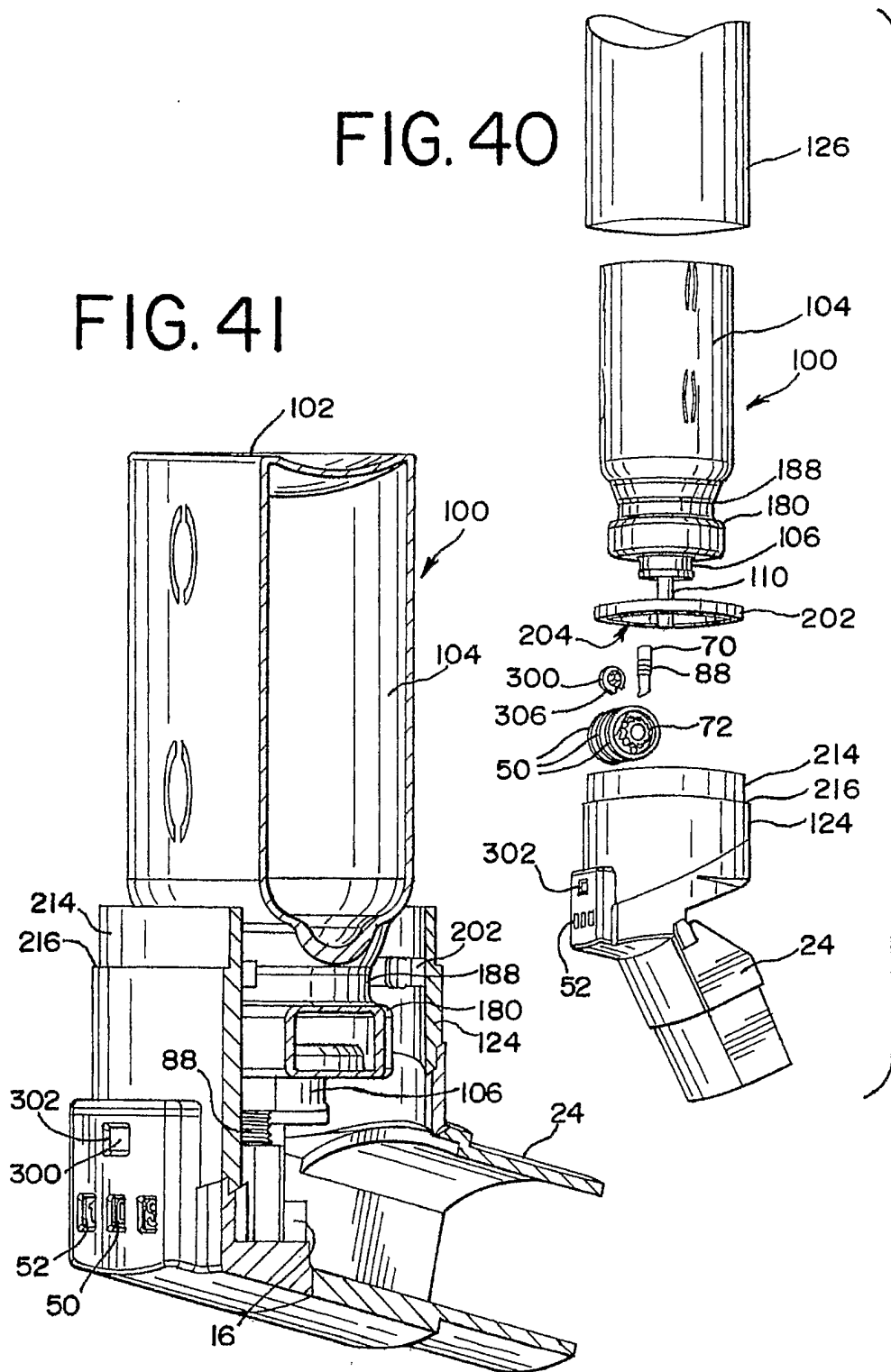

FIG. 42

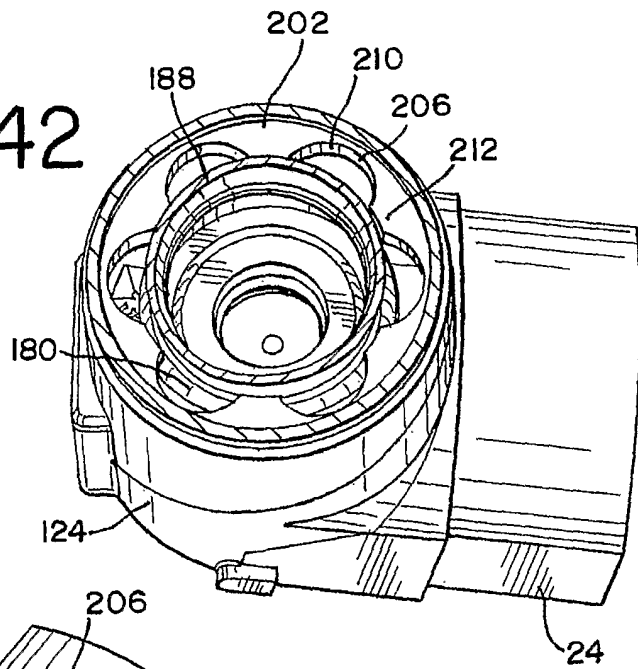

FIG. 43

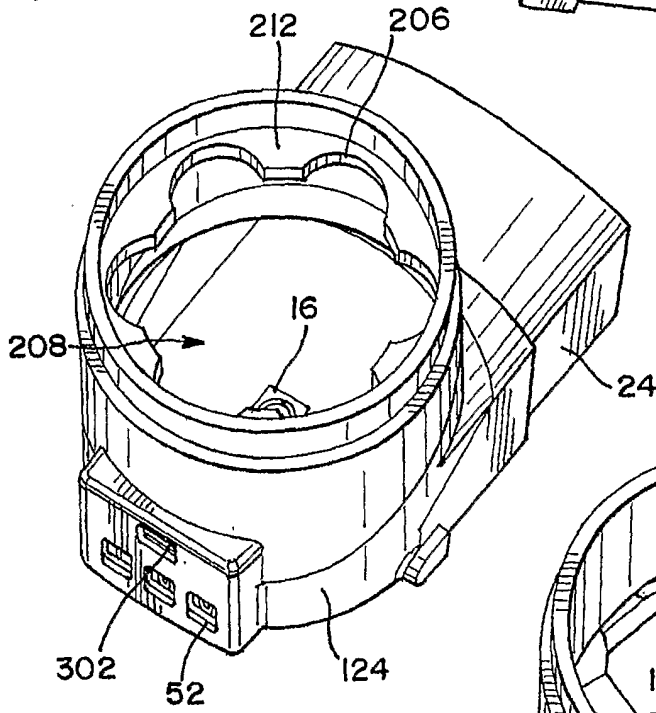
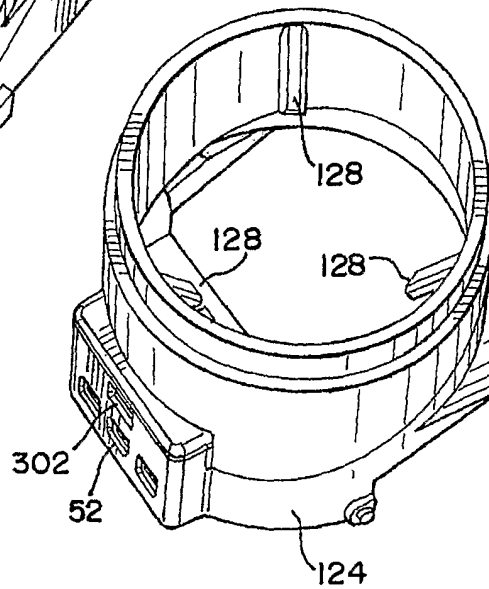
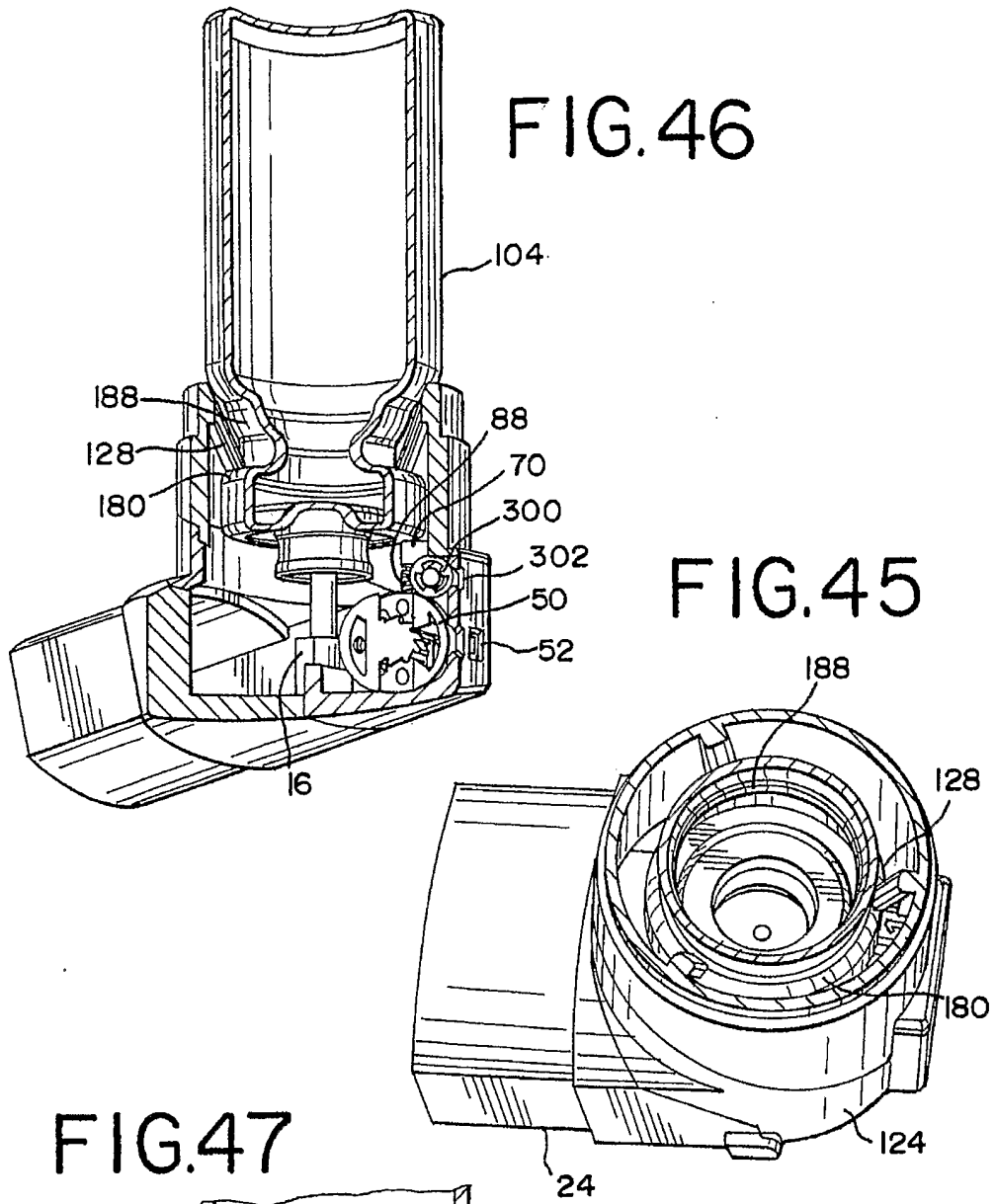

FIG. 44





INTERNATIONAL SEARCH REPORT

International application No.
PCT/IB2006/000084

<p>A. CLASSIFICATION OF SUBJECT MATTER IPC: A61M 15/00 (2006.01) , A61M 11/00 (2006.01) , A61J 1/00 (2006.01) According to International Patent Classification (IPC) or to both national classification and IPC</p>																						
<p>B. FIELDS SEARCHED</p> <p>Minimum documentation searched (classification system followed by classification symbols) IPC (2006.01): A651M 15/09 A61M 11/00 & A61J 1/00. CPC: 128/63, 128/64 & 128/71-73. USPC: 128/200.23 & 222/23</p> <p>Documentation searched other than minimum documentation to the extent that such documents are included in the fields searched</p> <p>Electronic database(s) consulted during the international search (name of database(s) and, where practicable, search terms used) Canadian Patent Database, Espacenet, Delphion, WEST, USPTO, Internet (Google). Keywords (inexhaustive list: indicat*, count*, connect*, tether; key, lock*, security; bulb, cap, squeeze; collar, ring; lug, catch)</p>																						
<p>C. DOCUMENTS CONSIDERED TO BE RELEVANT</p> <table border="1"> <thead> <tr> <th>Category*</th> <th>Citation of document, with indication, where appropriate, of the relevant passages</th> <th>Relevant to claim No.</th> </tr> </thead> <tbody> <tr> <td>A</td> <td>CA 2 486 892 A1 (BONNEY et al) 17 December 1998 (17-12-1998) *the whole document*</td> <td>1 to 42 and 54 to 57</td> </tr> <tr> <td>A</td> <td>CA 2 181 789 (JEWETT et al) 06 June 1996 (06-06-1996) *page 17, lines 13 to 19; figure 1*</td> <td>1 to 42 and 54 to 57</td> </tr> <tr> <td>A</td> <td>CA 2 414 118 (POLLET et al) 17 January 2002 (17-01-2002) *page 7, line 28 to page 11, line 14; figures 4 to 8*</td> <td>13 to 16, 31 to 33 and 42</td> </tr> <tr> <td>A, P</td> <td>GB 2 414 187 A (INGRAM et al) 23 November 2005 (23-11-2005) *the whole document*</td> <td>43 to 52</td> </tr> <tr> <td>A</td> <td>EP 1 369 139 A1 (EDUARD) 10 December 2003 (10-12-2003) *column 12, line 7 to column 20, line 58; figures 4 to 9*</td> <td>43 to 52</td> </tr> <tr> <td>A</td> <td>CA 2 315 777 A1 (BLACKER et al) 22 July 1999 (22-07-1999) *page 34, line 5 to page 38, line 4*</td> <td>43 to 52</td> </tr> </tbody> </table>		Category*	Citation of document, with indication, where appropriate, of the relevant passages	Relevant to claim No.	A	CA 2 486 892 A1 (BONNEY et al) 17 December 1998 (17-12-1998) *the whole document*	1 to 42 and 54 to 57	A	CA 2 181 789 (JEWETT et al) 06 June 1996 (06-06-1996) *page 17, lines 13 to 19; figure 1*	1 to 42 and 54 to 57	A	CA 2 414 118 (POLLET et al) 17 January 2002 (17-01-2002) *page 7, line 28 to page 11, line 14; figures 4 to 8*	13 to 16, 31 to 33 and 42	A, P	GB 2 414 187 A (INGRAM et al) 23 November 2005 (23-11-2005) *the whole document*	43 to 52	A	EP 1 369 139 A1 (EDUARD) 10 December 2003 (10-12-2003) *column 12, line 7 to column 20, line 58; figures 4 to 9*	43 to 52	A	CA 2 315 777 A1 (BLACKER et al) 22 July 1999 (22-07-1999) *page 34, line 5 to page 38, line 4*	43 to 52
Category*	Citation of document, with indication, where appropriate, of the relevant passages	Relevant to claim No.																				
A	CA 2 486 892 A1 (BONNEY et al) 17 December 1998 (17-12-1998) *the whole document*	1 to 42 and 54 to 57																				
A	CA 2 181 789 (JEWETT et al) 06 June 1996 (06-06-1996) *page 17, lines 13 to 19; figure 1*	1 to 42 and 54 to 57																				
A	CA 2 414 118 (POLLET et al) 17 January 2002 (17-01-2002) *page 7, line 28 to page 11, line 14; figures 4 to 8*	13 to 16, 31 to 33 and 42																				
A, P	GB 2 414 187 A (INGRAM et al) 23 November 2005 (23-11-2005) *the whole document*	43 to 52																				
A	EP 1 369 139 A1 (EDUARD) 10 December 2003 (10-12-2003) *column 12, line 7 to column 20, line 58; figures 4 to 9*	43 to 52																				
A	CA 2 315 777 A1 (BLACKER et al) 22 July 1999 (22-07-1999) *page 34, line 5 to page 38, line 4*	43 to 52																				
<p><input checked="" type="checkbox"/> Further documents are listed in the continuation of Box C. <input type="checkbox"/> See patent family annex.</p> <table border="1"> <tbody> <tr> <td>* Special categories of cited documents :</td> <td>"T" later document published after the international filing date or priority date and not in conflict with the application but cited to understand the principle or theory underlying the invention</td> </tr> <tr> <td>"A" document defining the general state of the art which is not considered to be of particular relevance</td> <td>"X" document of particular relevance; the claimed invention cannot be considered novel or cannot be considered to involve an inventive step when the document is taken alone</td> </tr> <tr> <td>"E" earlier application or patent but published on or after the international filing date</td> <td>"Y" document of particular relevance; the claimed invention cannot be considered to involve an inventive step when the document is combined with one or more other such documents, such combination being obvious to a person skilled in the art</td> </tr> <tr> <td>"L" document which may throw doubts on priority claim(s) or which is cited to establish the publication date of another citation or other special reason (as specified)</td> <td>"&" document member of the same patent family</td> </tr> <tr> <td>"O" document referring to an oral disclosure, use, exhibition or other means</td> <td></td> </tr> <tr> <td>"P" document published prior to the international filing date but later than the priority date claimed</td> <td></td> </tr> </tbody> </table>		* Special categories of cited documents :	"T" later document published after the international filing date or priority date and not in conflict with the application but cited to understand the principle or theory underlying the invention	"A" document defining the general state of the art which is not considered to be of particular relevance	"X" document of particular relevance; the claimed invention cannot be considered novel or cannot be considered to involve an inventive step when the document is taken alone	"E" earlier application or patent but published on or after the international filing date	"Y" document of particular relevance; the claimed invention cannot be considered to involve an inventive step when the document is combined with one or more other such documents, such combination being obvious to a person skilled in the art	"L" document which may throw doubts on priority claim(s) or which is cited to establish the publication date of another citation or other special reason (as specified)	"&" document member of the same patent family	"O" document referring to an oral disclosure, use, exhibition or other means		"P" document published prior to the international filing date but later than the priority date claimed										
* Special categories of cited documents :	"T" later document published after the international filing date or priority date and not in conflict with the application but cited to understand the principle or theory underlying the invention																					
"A" document defining the general state of the art which is not considered to be of particular relevance	"X" document of particular relevance; the claimed invention cannot be considered novel or cannot be considered to involve an inventive step when the document is taken alone																					
"E" earlier application or patent but published on or after the international filing date	"Y" document of particular relevance; the claimed invention cannot be considered to involve an inventive step when the document is combined with one or more other such documents, such combination being obvious to a person skilled in the art																					
"L" document which may throw doubts on priority claim(s) or which is cited to establish the publication date of another citation or other special reason (as specified)	"&" document member of the same patent family																					
"O" document referring to an oral disclosure, use, exhibition or other means																						
"P" document published prior to the international filing date but later than the priority date claimed																						
<p>Date of the actual completion of the international search</p> <p>24 May 2006 (24-05-2006)</p>	<p>Date of mailing of the international search report</p> <p>2 June 2006 (02-06-2006)</p>																					
<p>Name and mailing address of the ISA/CA</p> <p>Canadian Intellectual Property Office Place du Portage I, C114 - 1st Floor, Box PCT 50 Victoria Street Gatineau, Quebec K1A 0C9 Facsimile No.: 001(819)953-2476</p>	<p>Authorized officer</p> <p>Kristian Ewen (819) 934-4269</p>																					

INTERNATIONAL SEARCH REPORT

International application No.
PCT/IB2006/000084

C (Continuation). DOCUMENTS CONSIDERED TO BE RELEVANT

Category*	Citation of document, with indication, where appropriate, of the relevant passages	Relevant to claim No.
A	US 4 973 250 (MILMAN) 27 November 1990 (27-11-1990) *the whole document*	53
A	CA 2 420 171 A1 (ODESSKY et al) 07 March 2002 (07-03-2002) *page 4, line 25 to page 8, line 9; figures 1 to 4*	53
A	CA 2 383 425 A1 (SEPPÄLÄ) 29 March 2001 (29-03-2001) *page 7, lines 1 to 31; figures 1 to 6*	53
X	US 5 215 079 (FINE et al) 01 June 1993 (01-06-1993)	58
Y	*column 3, lines 4 to 11; figures 3A and 3B*	59 to 62
Y	US 6 155 251 (HAUSER) 05 December 2000 (05-12-2000) *column 2, lines 57 to 65; figure 4)	59 to 62

INTERNATIONAL SEARCH REPORT
Information on patent family members

International application No.
PCT/IB2006/000084

Patent Document Cited in Search Report	Publication Date	Patent Family Member(s)	Publication Date
CA2486892 A1	17-12-1998	AT215389T T	15-04-2002
		AT251481T T	15-10-2003
		AT274952T T	15-09-2004
		AT305320T T	15-10-2005
		AU741218 B2	29-11-2001
		AU741693 B2	06-12-2001
		AU742913 B2	17-01-2002
		AU8213798 A	30-12-1998
		AU8213898 A	30-12-1998
		AU8436498 A	30-12-1998
		BR9809554 A	20-06-2000
		BR9809980 A	01-08-2000
		BR9809983 A	01-08-2000
		CA2293484 A1	17-12-1998
		CA2293487 A1	17-12-1998
		CA2293488 A1	17-12-1998
		CA2486894 A1	17-12-1998
		CN1150038C C	19-05-2004
		DE69804609D D1	08-05-2002
		DE69804609T T2	12-09-2002
		DE69818819D D1	13-11-2003
		DE69818819T T2	12-08-2004
		DE69826039D D1	07-10-2004
		DE69826039T T2	22-09-2005
		DE69831739D D1	03-11-2005
		DE69831739T T2	27-04-2006
		DK986412T T3	22-07-2002
		DK988077T T3	12-01-2004
		DK1163922T T3	29-11-2004
		EA1396 B1	26-02-2001
		EG21520 A	28-11-2001
		EP0986412 A1	22-03-2000
		EP0988077 A1	29-03-2000
		EP0988078 A1	29-03-2000
		EP1163922 A2	19-12-2001
		EP1475116 A2	10-11-2004
		ES2175737T T3	16-11-2002
		ES2207841T T3	01-06-2004
		ES2227031T T3	01-04-2005
		ES2249834T T3	01-04-2006
		GB9711889D D0	06-08-1997
		GB9721875D D0	17-12-1997
		HK1023956 A1	27-09-2002
		HR980304 A1	30-04-1999
		HU0003328 A2	28-02-2001
		ID24128 A	06-07-2000
		IL133219 A	15-12-2004
IN192609 A1	08-05-2004		
JP3487865B2 B2	19-01-2004		
JP3487866B2 B2	19-01-2004		
JP3487867B2 B2	19-01-2004		

INTERNATIONAL SEARCH REPORT

International application No.
PCT/IB2006/000084

Patent Document Cited in Search Report	Publication Date	Patent Family Member(s)	Publication Date
CA2486892 A1	17-12-1998	AT215389T T	15-04-2002
		MA24562 A1	31-12-1998
		NO996085 A	09-02-2000
		NZ501379 A	26-04-2002
		PL188988B B1	31-05-2005
		PT986412T T	30-09-2002
		PT988077T T	31-03-2004
		PT1163922T T	31-12-2004
		TR9903066T T2	21-07-2000
		TW533865Y Y	21-05-2003
		US6360739 B1	26-03-2002
		US6474331 B1	05-11-2002
		US6601582 B2	05-08-2003
		US2003209239 A1	13-11-2003
		WO9856444 A1	17-12-1998
		WO9856445 A1	17-12-1998
		WO9856446 A1	17-12-1998
		ZA9804944 A	08-12-1999
		CA2181789	06-06-1996
AT238822T T	15-05-2003		
AU687290 B2	19-02-1998		
AU730788 B2	15-03-2001		
AU4236096 A	19-06-1996		
AU7174596 A	29-05-1997		
CA2190204 A1	23-05-1997		
DE69524865D D1	07-02-2002		
DE69524865T T2	29-08-2002		
DE69627786D D1	05-06-2003		
DE69627786T T2	25-03-2004		
DK775499T T3	25-08-2003		
EP0746366 A1	11-12-1996		
EP0775499 A2	28-05-1997		
ES2170814T T3	16-08-2002		
ES2199275T T3	16-02-2004		
JP3307946B2 B2	29-07-2002		
JP3583569B2 B2	04-11-2004		
NO315310B B1	18-08-2003		
NO316356B B1	19-01-2004		
NZ297246 A	22-09-1997		
NZ299619 A	24-11-1997		
PT775499T T	31-10-2003		
US5544647 A	13-08-1996		
US5622163 A	22-04-1997		
WO9616686 A1	06-06-1996		
ZA9510129 A	06-06-1996		

INTERNATIONAL SEARCH REPORT

International application No.
PCT/IB2006/000084

Patent Document Cited in Search Report	Publication Date	Patent Family Member(s)	Publication Date
CA2414118 A1	17-01-2002	AU6620501 A	21-01-2002
		EP1296733 A1	02-04-2003
		GB0016670D D0	23-08-2000
		GB0020600D D0	11-10-2000
		JP2004502503T T	29-01-2004
		US2004089292 A1	13-05-2004
		WO0204056 A1	17-01-2002
GB2414187 A	23-11-2005	GB0411384D D0	23-06-2004
		WO2005113044 A1	01-12-2005
EP1369139 A1	10-12-2003	AU2003233609 A1	19-12-2003
		EP1509269 A1	02-03-2005
		JP2006512103T T	13-04-2006
		US2005209558 A1	22-09-2005
		WO03101514 A1	11-12-2003
CA2315777 A1	22-07-1999	AU753568 B2	24-10-2002
		AU1777499 A	02-08-1999
		DE69918267D D1	29-07-2004
		DE69918267T T2	28-07-2005
		EP1047467 A2	02-11-2000
		EP1449557 A2	25-08-2004
		JP2002528144T T	03-09-2002
		US6161724	19-12-2000
		US6142339 A	07-11-2000
		US6435372 B1	20-08-2002
		US6561384 B2	13-05-2003
		US6938796 B2	06-09-2005
		US6997349 B2	14-02-2006
		US2006086749 A1	27-04-2006
		WO9936115 A2	22-07-1999
ZA9900197 A	27-09-2000		
US4973250	27-11-1990	NONE	
CA2420171 A1	07-03-2002	AU8720901 A	13-03-2002
		CN1452574 A	29-10-2003
		DE10196564T T0	28-08-2003
		GB0306853D D0	30-04-2003
		MXPA03001734 A	10-09-2004
		US6354337 B1	12-03-2002
		WO0218209	07-03-2002
CA2383425 A1	29-03-2001	AU7290800 A	24-04-2001
		EP1231964 A2	21-08-2002
		JP2003509172T T	11-03-2003
		US6886560 B1	03-05-2005

INTERNATIONAL SEARCH REPORTInternational application No.
PCT/IB2006/000084

Patent Document Cited in Search Report	Publication Date	Patent Family Member(s)	Publication Date
---	---------------------	----------------------------	---------------------

US5215079	01-06-1993	NONE	
-----------	------------	------	--

US6155251	05-12-2000	US5904139 A	18-05-1999
-----------	------------	-------------	------------

Box No. II Observations where certain claims were found unsearchable (Continuation of item 2 of the first sheet)

This international search report has not been established in respect of certain claims under Article 17(2)(a) for the following reasons :

1. Claim Nos. :
because they relate to subject matter not required to be searched by this Authority, namely :

2. Claim Nos. :
because they relate to parts of the international application that do not comply with the prescribed requirements to such an extent that no meaningful international search can be carried out, specifically :

3. Claim Nos. :
because they are dependant claims and are not drafted in accordance with the second and third sentences of Rule 6.4(a).

Box No. III Observations where unity of invention is lacking (Continuation of item 3 of first sheet)

This International Searching Authority found multiple inventions in this international application, as follows :

The claims are directed to a plurality of inventions. The claims must be limited to one invention only as set out in PCT Rule 13. Group A: Claims 1 to 42 and 54 to 57 are directed to a connector between a housing and a container with a valve stem. The connector maintains a connection between the container and the housing when the valve stem is disengaged from the housing.

Continued on page 8

1. As all required additional search fees were timely paid by the applicant, this international search report covers all searchable claims.
2. As all searchable claims could be searched without effort justifying additional fees, this Authority did not invite payment of additional fees.
3. As only some of the required additional search fees were timely paid by the applicant, this international search report covers only those claims for which fees were paid, specifically claim Nos. :
4. No required additional search fees were timely paid by the applicant. Consequently, this international search report is restricted to the invention first mentioned in the claims; it is covered by claim Nos. :

Remark on Protest The additional search fees were accompanied by the applicant's protest and, where applicable, the payment of a protest fee.

The additional search fees were accompanied by the applicant's protest but the applicable protest fee was not paid within the time limit specified in the invitation.

No protest accompanied the payment of additional search fees.

Continuation of Box III

Group B: Claims 43 to 52 are directed to a dispenser comprising a housing and featuring a key device having a mounting portion. The key device operates by the interaction of first and second rings on the mounting portion with corresponding first and second key portions on an indicating device housed in said housing. As doses are dispensed, gears connected with first and second key portions are rotated which, in turn, rotate first and second rings on said mounting portion. The result is a unique mating configuration for each dose dispensed.

Group C: Claim 53 is directed to a flexible, resilient cap fixed to an open end of a housing of a dispensing device. The cap prevents the removal of a container from the housing, disallowing a valve stem connected to said container from disengaging from said housing.

Group D: Claims 58 to 64 are directed to a dispenser featuring a catch portion for preventing disengagement of a valve stem connected to a container from being removed from a dispenser housing.