

No. 850,182.

PATENTED APR. 16, 1907.

S. S. POOR.
CIGARETTE BOX.

APPLICATION FILED DEC. 20, 1906.

2 SHEETS—SHEET 1.

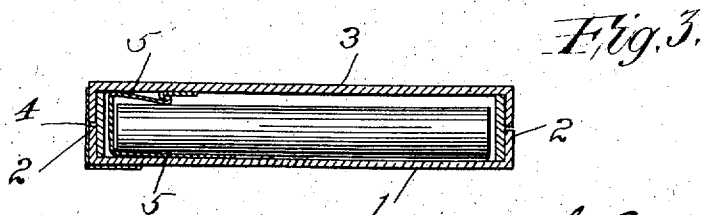
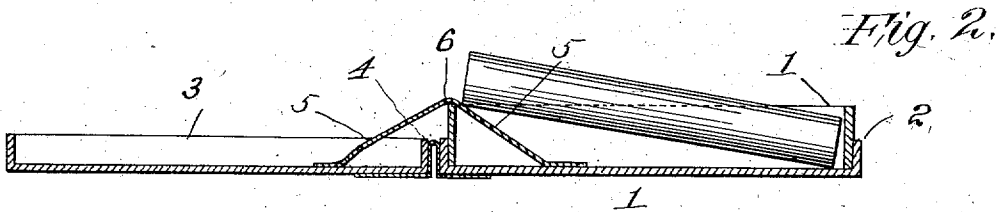
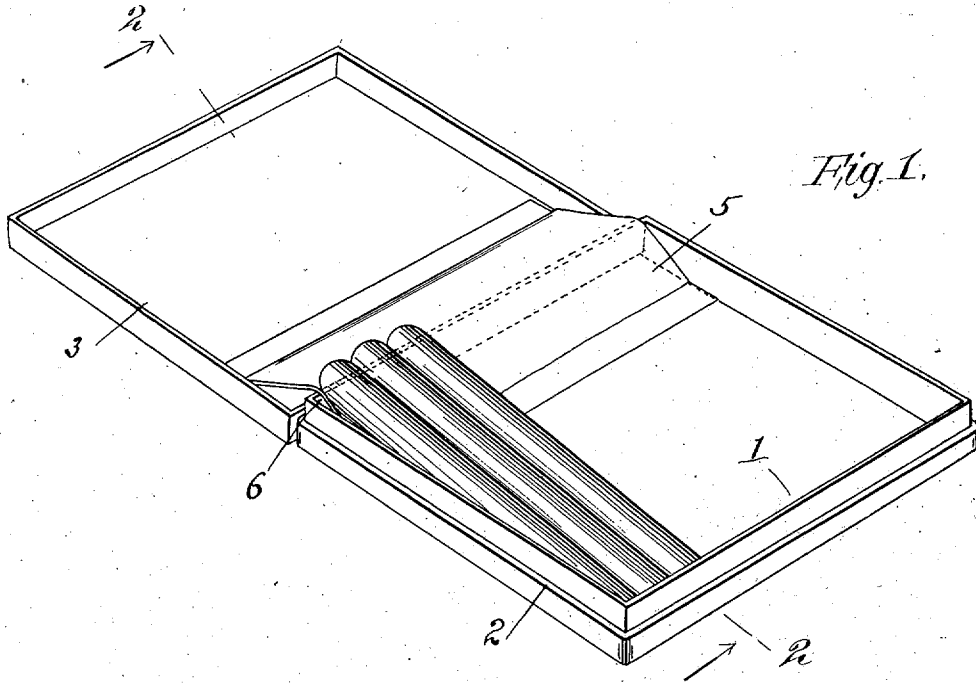

Witnesses
W. H. Benjamin
C. A. Kaufmann

Samuel S. Poor
Inventor
By his Attorney, Davis & Davis

No. 850,182.

PATENTED APR. 16, 1907.

S. S. POOR.
CIGARETTE BOX.

APPLICATION FILED DEC. 20, 1906.

2 SHEETS—SHEET 2.

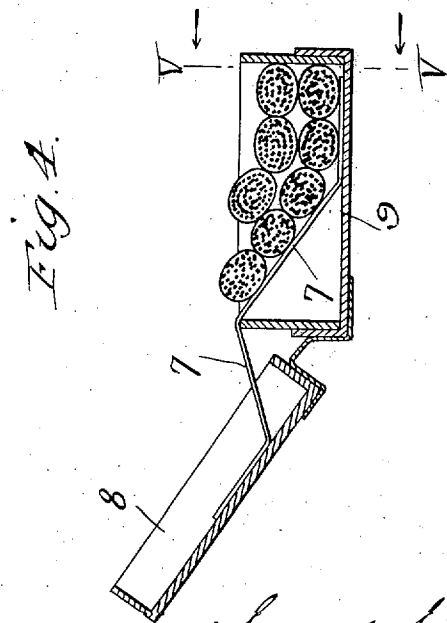
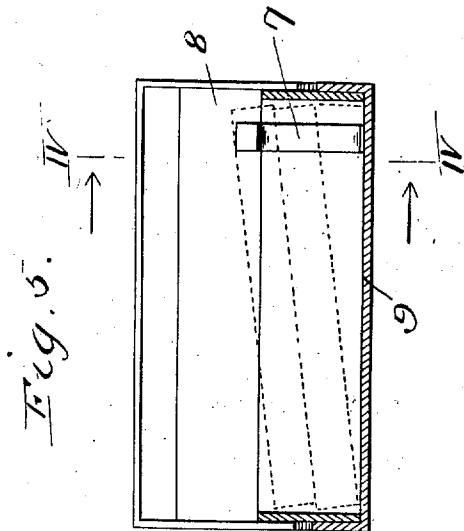

Witnesses
E. H. Kaufmann
Martha Fitzman

Samuel S. Poor
Inventor

By *his* Attorneys *David Davis*

UNITED STATES PATENT OFFICE.

SAMUEL S. POOR, OF WESTFIELD, NEW JERSEY.

CIGARETTE-BOX.

No. 850,182.

Specification of Letters Patent.

Patented April 16, 1907.

Application filed December 20, 1906. Serial No. 348,792.

To all whom it may concern:

Be it known that I, SAMUEL S. POOR, a citizen of the United States, residing at Westfield, county of Union, State of New Jersey, have invented certain new and useful Improvements in Cigarette-Boxes, of which the following is a specification, reference being had therein to the accompanying drawings, in which—

10 Figure 1 is a perspective view of the box open and showing cigarettes therein; Fig. 2, a longitudinal vertical sectional view on the line II II of Fig. 1; Fig. 3, a sectional view showing the box folded and a cigarette therein; Fig. 4, a sectional view on the line IV IV of Fig. 5 of a box, showing a slightly different construction; and Fig. 5, a sectional view taken on the line V V of Fig. 4.

The main object of this invention is to provide means whereby upon the opening of the box-cover one end of each of the cigarettes in the box will be raised above the upper edge of the box in order that one of them may be readily grasped and separated from the adjoining cigarettes and removed from the box.

Other objects of the invention will appear hereinafter.

As cigarettes are ordinarily packed for the retail trade they fit very tightly in the boxes and it is very difficult to remove one of them, it being frequently necessary to grasp several and to force them bodily from the box. This is very objectionable, particularly when the one to open the box offers them to a companion. It is embarrassing to the one to whom the cigarettes are offered to be forced to handle practically all the cigarettes in the box before he can secure one. This invention avoids this objection.

Referring to the various parts by numerals, 1 designates the body of the box, which is provided with the ledge 2 of about one-half the height of the box on the outer side thereof. 3 is the cover of the box, hinged to the body part at the upper edge of the ledge 2, as shown at 4 in Fig. 2. Secured to the bottom of the box parallel with the hinge thereof is a lifting-web 5, which extends entirely across the hinge end of the box. This web 5 extends from its pasted box end along the bottom of the box to the hinge-wall 6, up said hinge-wall, and then along the inner side of the cover, its other end being pasted or otherwise secured to the

cover a suitable distance from the hinge. When the cigarettes are in the box and the cover is closed, said web incloses or extends around the ends of the cigarettes. When the cover is opened, the web is pulled across the upper edge of the hinge-wall, as shown in Fig. 2, said web extending on an incline from the upper edge of said wall downward to the point of attachment in the box. The web is of such length that when the box is open, as shown in Fig. 2, it will be drawn tightly over the upper edge of the hinge-wall and the ends of the cigarettes resting on said web will be raised above the upper edge of the box, as shown clearly in Figs. 1 and 2. When in this position, the upward-projecting ends of the cigarettes may be grasped and any one of them removed from the box. The web 5 is preferably made of thin readily-foldable paper, so that when the box is again closed the cigarettes automatically press the web down into the bottom of the box.

The web 5 not only serves to lift the cigarettes, but also strengthens and braces the joint between the cover and the box when the cover is in its full-open position, as shown in Fig. 2.

Instead of employing a web extending the entire length of the hinge-wall of the box I may employ a cord or ribbon, as shown in Figs. 4 and 5. I prefer to employ this form of device in those boxes in which cigarettes are packed in two layers. In this arrangement of the invention the band or cord 7 is pasted to the cover 8 near one end of the hinge-wall and is carried across the hinge-wall and secured to the inner side of the bottom 9 of the box. In this arrangement the band 7 will lift only one end of the cigarettes, as indicated in dotted lines in Fig. 5.

It will be noted that in the form of the device shown in Fig. 1 the cigarettes are arranged perpendicular to the hinge-wall—that is to say, at right angles thereto—while as shown in Figs. 4 and 5 they are parallel with the hinge-wall of the box and it is only necessary to use the band near one end thereof.

It will be readily understood that the web as shown in Fig. 1 need not extend throughout the entire length of the hinge-wall of the box, as a web broad enough to lift two or three cigarettes would be sufficient. I prefer, however, to use a broad strip, as shown. Having thus described my invention, what

I claim as new, and desire to secure by Letters Patent, is—

1. A cigarette-box comprising a body part, a cover hinged thereto below the upper edge of the box and a flexible cigarette-lifting web secured to the inner side of the bottom of the box parallel with the hinge-wall thereof and a suitable distance inward from the said wall, the other end of said web being secured to the inner side of the cover a suitable distance from the hinge, said web being of such length that when the cover is open it will be drawn taut across the edge of the hinge-wall and lift the ends of the cigarettes lying thereon, and take the strain off the hinge.

2. A box for cigarettes comprising a body part and a cover hinged thereto, of a flexible, foldable lifting-strip secured to the bottom of the box a suitable distance inward from the hinge-wall and on which the cigarettes lie, said strip extending up the hinge-wall and being secured to the cover at a suitable distance from the hinge, whereby when the box is open said strip will be drawn taut across the hinge-wall and lift the cigarettes lying thereon.

3. A cigarette-box comprising a body part and a cover hinged thereto below the upper edge of the box, of a flexible, foldable lifting-web secured to the inner side of the box parallel with the hinge-wall and extending

the entire length thereof and on which one end of the cigarettes lie, said web extending up the hinge-wall and secured at its other end to the cover a suitable distance from the hinge, the free portion of said web being long enough to permit the cover to be opened to bring its top in the same horizontal plane with the bottom of the box, the web being drawn taut over the hinge-wall and lifting the ends of the cigarettes lying thereon, and in its full-open position relieving the cover-hinge of all strain.

4. A cigarette-box comprising a body part and a cover hinged thereto below the upper edge of the box, of a broad lifting-web lying within the box under one end of the cigarettes therein and extending up the hinge-wall thereof and being secured to the inner surface of the cover a suitable distance from the hinge thereof, whereby when the cover is thrown to its open position the lifting-web will be drawn over the edge of the hinge-wall of the box and the cigarettes lying thereon within the box will be raised at their ends adjacent the hinge-wall.

In testimony whereof I hereunto affix my signature, in the presence of two witnesses, this 18th day of December, 1906.

SAMUEL S. POOR.

Witnesses:

WM. R. DAVIS,
E. H. KAUFMANN.