

(19) **DANMARK**

(10) **DK/EP 3785681 T3**



(12) **Oversættelse af
europæisk patentskrift**

Patent- og
Varemærkestyrelsen

-
- (51) Int.Cl.: **A 61 F 5/445 (2006.01)** **A 61 F 5/44 (2006.01)** **A 61 F 5/448 (2006.01)**
- (45) Oversættelsen bekendtgjort den: **2022-11-28**
- (80) Dato for Den Europæiske Patentmyndigheds bekendtgørelse om meddelelse af patentet: **2022-10-19**
- (86) Europæisk ansøgning nr.: **18887227.9**
- (86) Europæisk indleveringsdag: **2018-11-10**
- (87) Den europæiske ansøgnings publiceringsdag: **2021-03-03**
- (86) International ansøgning nr.: **CN2018114929**
- (87) Internationalt publikationsnr.: **WO2020010766**
- (30) Prioritet: **2018-07-10 CN 201810752868**
- (84) Designerede stater: **AL AT BE BG CH CY CZ DE DK EE ES FI FR GB GR HR HU IE IS IT LI LT LU LV MC MK MT NL NO PL PT RO RS SE SI SK SM TR**
- (73) Patenthaver: **ZHENDE MEDICAL CO., LTD., Gaobei Industrial Zone , Gaobu Town , Yuecheng District, Shaoxing, Zhejiang 312035, Kina**
- (72) Opfinder: **HU, Xiuyuan, Gaobei Industrial Zone, Gaobu Town, Yuecheng District, Shaoxing, Zhejiang 312035, Kina**
ZHANG, Rui, Gaobei Industrial Zone, Gaobu Town, Yuecheng District, Shaoxing, Zhejiang 312035, Kina
LI, Zheng, Gaobei Industrial Zone, Gaobu Town, Yuecheng District, Shaoxing, Zhejiang 312035, Kina
- (74) Fuldmægtig i Danmark: **NORDIC PATENT SERVICE A/S, Bredgade 30, 1260 København K, Danmark**
- (54) Benævnelse: **STOMIAFFALDSMATERIALEOPSAMLINGSANORDNING**
- (56) Fremdragne publikationer:
CN-A- 102 481 201
CN-A- 104 434 372
CN-Y- 2 683 075
US-A1- 2003 220 621
US-A1- 2013 197 458

DESCRIPTION

FIELD OF THE INVENTION

[0001] This invention relates to a field of a medical product and, more particularly, to an ostomy waste matter collection device, according to claim 1.

BACKGROUND OF THE INVENTION

[0002] The ostomy is generally aimed at lesions of the rectal and the bladder (such as rectal cancer, bladder cancer, intestinal obstruction, etc.). In order to save the patient's life, the doctor surgically removes the lesions. For example, the rectum and anal canal are removed for the rectal cancer, and the bladder is removed for the bladder cancer, then an opening is made on the left or right side of the patient's abdomen. The stool or urine is involuntarily excreted through the ostomy. This kind of patients will need to attach a pouch to the ostomy to place the waste matter after leaving the hospital, and this pouch is usually called an ostomy pouch. Currently, the ostomy pouch is usually adhered to the skin surrounding the ostomy through a hydrocolloid flange (or other sticky flanges). The incidence of problems of the skin surrounding the ostomy is as high as 60%, which seriously affects the quality of life of the person with the ostomy. These problems of the skin include irritant dermatitis and allergic dermatitis caused by the sticky flange, mechanical damage caused by peeling the sticky flange from the skin, and skin impregnation and fungal infection caused by leakage of the waste matter. A hole with the same size as the ostomy is cut in the center of the existing ostomy pouch flange on the market, and a gap between the opening of the flange and the ostomoy is coated with a leakage-proof paste. The main problem is that the waste matter is exposed on the exposed ostomy, and the waste matter leaks inward along the exposed ostomy and reaches the skin surrounding the ostomy, thereby causing a fester of the skin surrounding the ostomy. This invention will solve these problems. US2013/197458 discloses an ostomy waste matter collection device according to the preamble of claim 1.

BRIEF SUMMARY OF THE INVENTION

[0003] To solve deficiencies in the prior art, this invention provides an ostomy waste matter collection device as claimed in claim 1. The second sealing ring and the sealing member cooperate to improve the sealing property, thereby avoiding leakage of the waste matter; by disposing the discharge valve, the discharge of the waste matter in the intestine can be controlled, such that the patient with the ostomy can regularly discharge the waste matter; and by disposing the ostomy protection assembly, the waste matter in the intestine can be effectively controlled and prevented from leaking to the skin surrounding the ostomy, thereby avoiding ulceration of the skin and ensuring health of the patient. The elastic bag preferably is

coated with a lubricating and sealing reagent.

[0004] An absorbent material is preferably disposed between the turning horn mouth and the ostomy exposed portion.

[0005] The ostomy waste matter collection device may further include an extension tube connected with the ostomy connection tube.

[0006] The ostomy waste matter collection device may further include a collection pocket connected with the extension tube, and one end of the collection pocket may be provided with a discharge controlling assembly.

[0007] The discharge controlling assembly may include: a sealing pocket extended from the collection pocket, a self-sealing strip fixed at the sealing pocket, a soft magnetic strip disposed at a lower end of the self-sealing strip, and a handle fixed at the sealing pocket and located at a lower end of the soft magnetic strip.

[0008] Benefits of this invention are as follow.

[0009] In this invention, after the second sealing ring enters the ostomy, the second sealing ring opens the intestinal wall and is tightly close to the abdominal wall, and the second sealing ring and the elastic ostomy connection tube cooperate to form a first section sealing; the elastic bag is inflated through the second inflatable connection tube, and the elastic bag is tightly close to the intestinal wall forming a second section sealing; and the first section sealing and the second section sealing cooperate to prevent the waste matter in the intestine from leaking along the intestinal wall.

[0010] The discharge valve is the multi-cavity inflatable bag, the multi-cavity inflatable bag is inflated, and bags expand inward to close the cavity of the ostomy connection tube. In this way, the discharge of the waste matter in the intestine can be controlled, such that the patient with the ostomy can regularly discharge the waste matter.

[0011] By disposing the ostomy protection assembly, the structure that is turned outward along the ostomy can protect the ostomy intestinal tissue exposed outside the abdominal wall, and the waste matter in the intestine can be effectively controlled and prevented from leaking to the skin surrounding the ostomy, thereby avoiding ulceration of the skin and ensuring health of the patient.

[0012] The second sealing ring and the sealing member cooperate, such that the ostomy connection tube can be fixed in the ostomy stably, and the sticky flange is avoided to be adhered around the ostomy, thereby improving comfort and eliminating skin problems brought by the sticky flange.

BRIEF DESCRIPTION OF THE DRAWINGS

[0013]

FIG. 1 is a structural schematic diagram of one embodiment according to this invention;

FIG. 2 is a structural schematic diagram of one embodiment when a discharge valve is not inflated according to this invention;

FIG. 3 is a structural schematic diagram of one embodiment when the discharge valve is inflated according to this invention;

FIG. 4 is a structural schematic diagram of one embodiment during usage according to this invention;

FIG. 5 is a schematic diagram of an ostomy; and

FIG. 6 is a structural schematic diagram of one embodiment of a collection pocket according to this invention.

[0014] Figure reference numerals:

1 ostomy connection tube, 2 first sealing ring, 3 elastic bag, 4 second inflatable connection tube, 5 multi-cavity inflatable bag, 6 first inflatable connection tube, 7 second sealing ring, 8 absorbent material, 9 ostomy exposed portion, 10 abdominal wall, 11 intraabdominal intestinal tract, 12 turning horn mouth, 13 extension tube, 14 collection pocket, 15 self-sealing strip, 16 sealing pocket, and 17 handle.

DETAILED DESCRIPTION OF THE INVENTION

[0015] This invention is described in detail below in combination with the accompanying drawings and specific embodiments.

[0016] An ostomy waste matter collection device includes: an ostomy connection tube 1 fixed in an ostomy, a discharge valve disposed in the ostomy connection tube 1 and used for controlling the discharge of the waste matter, a sealing member disposed between the ostomy connection tube 1 and the abdominal wall for sealing, a turning outward line disposed between the discharge valve and the sealing member, and an ostomy protection assembly covering the ostomy exposed outside the abdominal wall and being connected with the ostomy connection tube 1. As a preferred way, the ostomy connection tube 1 is tubular taking an elastic film as the wall.

[0017] The discharge valve includes a multi-cavity inflatable bag 5 disposed in the ostomy connection tube 1 and a first inflatable connection tube 6 connected with the multi-cavity

inflatable bag. FIG. 2 shows an opening state when the multi-cavity inflatable bag 5 is not inflated. There are four cavities in the circle, and blanks around the center of the circle are waste matter passages. FIG. 3 shows a closed state when the multi-cavity inflatable bag 5 is inflated. There are four cavity bags 5-1, 5-2, 5-3, and 5-4 in the circle, the four cavity bags expand inward after being inflated, and the waste matter passages are closed.

[0018] The sealing member includes an annular elastic bag 3 disposed at the ostomy connection tube 1 and a second inflatable connection tube 4 connected with the elastic bag 3. In order to improve the sealing and comfort between the elastic bag 3 and the abdominal wall, the elastic bag 3 is coated with a lubricating and sealing reagent; as an embodiment, the lubricating and sealing reagent includes Vaseline or gel.

[0019] The ostomy protection assembly includes a turning horn mouth 12 extended at the ostomy connection tube 1 and used for covering an ostomy exposed portion, and a first sealing ring 2 disposed at ends of the turning horn mouth 12. It should be noted that in order to enable the ostomy connection tube 1 to be fixed in the ostomy in a sealing way, the diameter of the first sealing ring 2 is larger than the size of the ostomy. An absorbent material 8 is disposed between the turning horn mouth 12 and the ostomy exposed portion. It should be noted that the absorbent material adopted in this invention absorbs liquid of which the weight is more than 15 times heavier than the weight of the absorbent material. As an embodiment, the absorbent material 8 includes a PU foam, a superabsorbent nonwoven fabric (SAP), a hydrophilic fiber nonwoven fabric gelled after absorbing liquid, and the like. A second sealing ring 7 fixed in the ostomy is disposed at the turning outward line.

[0020] As shown in FIG. 1, the ostomy connection tube 1 is an elastic tube taking the elastic film as the wall, and one side of the tube is horn-shaped, that is, the turning horn mouth 12. Ends of the turning horn mouth 12 has a first sealing ring 2 made of the same elastic film as the tube, as a preferred way, the first sealing ring 2 is a first elastic O-shaped ring. The other end of the ostomy connection tube 1 is connected with a collection pocket 14, and the ostomy connection tube 1 can be connected with the collection pocket 14 as a whole or as two separate parts. There is an elastic bag 3 full of gas (liquid) 2-5 cm away from one side of the turning horn mouth 12 with the smaller diameter, and a second inflatable connection tube 4 of the elastic bag 3 is above the outer side of the ostomy connection tube 1. On the right side of the elastic bag 3, the multi-cavity inflatable bag 5 is disposed inside the ostomy connection tube 1, and the number of cavities of the multi-cavity inflatable bag 5 may be 2-10, preferably 4. The first inflatable connection tube 6 of the multi-cavity inflatable bag 5 is below the outer side of the elastic tube, and a second sealing ring 7 is disposed in the middle of the elastic bag 3 and the multi-cavity inflatable bag 5. As a preferred way, the second sealing ring 7 is a second elastic O-shaped ring. As an embodiment, the second elastic O-shaped ring can be connected with the ostomy connection tube 1 as a whole or as two separate parts.

[0021] As shown in FIG. 4, the process of use is as follow. During usage, the turning outward line is taken as the center line, and the turning horn mouth 12 with the first sealing ring 2 is turned outward till the elastic bag 3 is aligned with or close to the multi-cavity inflatable bag 5.

The outer wall of the elastic bag 3 is coated with the vaseline or gel for lubricating and sealing, and a layer of an annular superabsorbent material 8 is disposed at the right side of the outer side of the elastic bag 3. Then the second sealing ring 7 and the ostomy connection tube 1 are put inside the ostomy together, as shown in FIG. 5, 9 is the ostomy exposed portion, 10 is the abdominal wall, and 11 is an intraabdominal intestinal tract. After the second sealing ring 7 enters the ostomy, the second sealing ring 7 opens the intestinal wall and is tightly close to the abdominal wall, and the second sealing ring 7 and the elastic ostomy connection tube 1 cooperate to form a first section sealing; the elastic bag 3 is inflated through the second inflatable connection tube 4, and the elastic bag 3 is tightly close to the intestinal wall forming a second section sealing; and the first section sealing and the second section sealing is to prevent the waste matter in the intestine from leaking along the intestinal wall. The annular superabsorbent material 8 is disposed at an outlet of the ostomy outside the abdominal wall, which can absorb the waste matter in the intestine leaking slowly. The ostomy outside the abdominal wall is to suture the everted intestine at the abdominal wall, the first sealing ring 2 and the turning horn mouth 12 are turned outward toward the abdominal wall in the direction of the everted intestine, and the ostomy exposed outside the abdominal wall are covered, thereby protecting the exposed ostomy; and the multi-cavity inflatable bag 5 is inflated through the first inflatable connection tube 6, and four bags (5-1, 5-2, 5-3, 5-4) expand inward to close the cavity of the ostomy connection tube 1. In this way, the discharge of the waste matter in the intestine can be controlled, such that the patient the ostomy can regularly discharge the waste matter.

[0022] It should be noted that the second sealing ring 7 is disposed at the turning outward line. As one embodiment, the second sealing ring 7 is taken as the turning outward line, the turning horn mouth 12 with the first sealing ring 2 is turned outward, and two layers of the elastic material is sealed together to form the elastic bag 3 by a welding process or a heat sealing process in the position aligned with or close to the multi-cavity inflatable bag 5. As another embodiment, the second sealing ring 7 is not disposed, this position is taken as the turning outward line, the turning horn mouth 12 with the first sealing ring 2 is turned outward, and two layers of the elastic material is sealed together to form the elastic bag 3 by the welding process or the heat sealing process in the position aligned with or close to the multi-cavity inflatable bag 5.

[0023] As shown in FIG. 6, the ostomy waste matter collection device also includes an extension tube connected with the ostomy connection tube; and the person with the ostomy can put the extension tube in the waste matter collector. As one embodiment, the extension tube is connected with a collection pocket, and one end of the collection pocket is provided with a discharge controlling assembly. The discharge controlling assembly includes a sealing pocket 16 extended from the collection pocket, a self-sealing strip 15 fixed at the sealing pocket 16, a soft magnetic strip disposed at a lower end of the self-sealing strip 15, and a handle 17 fixed at the sealing pocket 16 and located at a lower end of the soft magnetic strip. The soft magnetic strip is designed to facilitate aligning the self-sealing strip 15 with the uneven position, which facilitates sealing and improves the sealing property; and the handle 17 is disposed to help open the sealing pocket 16 and the self-sealing strip 15, thereby discharging the waste matter.

This design makes it easy to discharge the waste matter and reuse it. When the person with the ostomy is unwilling to defecate regularly or it is inconvenient to defecate, the multi-cavity inflatable bag 5 can be inflated to temporarily leave the waste matter in the collection pocket 14.

[0024] This invention provides the ostomy waste matter collection device. The second sealing ring 7 and the sealing member cooperate to improve the sealing property, thereby avoiding the leakage of the waste matter; by disposing the discharge valve, the discharge of the waste matter in the intestine can be controlled, such that the patient with the ostomy can regularly discharge the waste matter; by disposing the ostomy protection assembly, the waste matter in the intestine can be effectively controlled and prevented from leaking to the skin surrounding the ostomy, thereby avoiding ulceration of the skin and ensuring health of the patient.

REFERENCES CITED IN THE DESCRIPTION

Cited references

This list of references cited by the applicant is for the reader's convenience only. It does not form part of the European patent document. Even though great care has been taken in compiling the references, errors or omissions cannot be excluded and the EPO disclaims all liability in this regard.

Patent documents cited in the description

- US2013197458A [0002]

Patentkrav

1. Stomiaffaldsmaterialeopsamlingsanordning omfattende en stomiforbindelsesslange (1), der er tilpasset til fastgørelse i en stomi, en udledningsventil, der er placeret i stomiforbindelsesslangen (1) og anvendes til styring af udledning af et affaldsmateriale, et tætnende element, der er placeret mellem stomiforbindelsesslangen (1) og en bugvæg (10), i anvendelse, til tætning, en ledning, der drejer udefter, og som er placeret mellem udledningsventilen og tætningselementet, og en stomibeskyttelsesanordning til afdækning af stomien, der er eksponeret uden for bugvæggen (10) og forbundet med stomiforbindelsesslangen (1),
- 5
- 10 **kendetegnet ved, at** udledningsventilen omfatter en oppustelig multihulrumspose (5), der er placeret i stomiforbindelsesslangen (1), og en første oppustelig forbindelsesslange (6), der er forbundet med den oppustelige multihulrumspose (5), hvilken oppustelig multihulrumspose (5) kan ekspanderes indefter for at lukke et hulrum i stomiforbindelsesslangen (1), når den oppustelige multihulrumspose (5) er oppustet;
- 15 hvor tætningselementet omfatter en elastisk pose (3), der er placeret ved stomiforbindelsesslangen (1), og en anden, oppustelig forbindelsesslange (4), der er forbundet med den elastiske pose (3);
- 20 hvor stomibeskyttelsesanordningen omfatter en drejende hornmunding (12), der udgår fra stomiforbindelsesslangen (1) og anvendes til afdækning af en stomieksponeret del (9), og en første tætningsring (2), der er placeret ved en ende af den drejende hornmunding (12);
- 25 hvor en anden tætningsring (7), der er fastgjort i stomien, i anvendelse, placeres ved den udefter drejende ledning;
- 30 hvor den udefter drejende ledning er en midterledning, når den drejende hornmunding (12) med den første tætningsring (2) drejes udefter, indtil den elastiske pose (3) flugter med eller er tæt på den oppustelige multihulrumspose (5);
- hvor den anden tætningsring (7) er tilpasset til at åbne en tarmvæg og være tæt på bugvæggen (10), efter at den anden tætningsring (7) trænger ind i stomien, og den anden tætningsring (7) og den elastiske stomiforbindelsesslange (1) er tilpasset til at samvirke for at danne en første sektionstætning; hvor den elastiske pose (3) kan oppustes via den anden oppustelige forbindelsesslange (4), og den elastiske pose (3) er tilpasset til at være tæt på tarmvæggen for at danne en anden sektionstætning; og den

første sektionstætning og den anden sektion er tilpasset til at samvirke tætnende for at forhindre affaldsmateriale i tarmen at lække langs med tarmvæggen.

- 5 **2.** Stomiaffaldsmaterialeopsamlingsanordning ifølge krav 1, hvor den elastiske pose (3) er coatet med et smørende og tætnende reagens.
- 3.** Stomiaffaldsmaterialeopsamlingsanordning ifølge krav 1, hvor et absorberende materiale er placeret mellem den drejende hornmunding (12) og den stomiekxponerede del (9).
- 10
- 4.** Stomiaffaldsmaterialeopsamlingsanordning ifølge krav 1, der endvidere omfatter en forlængesslange (13), der er forbundet med stomiforbindelsesslangen (1).
- 5.** Stomiaffaldsmaterialeopsamlingsanordning ifølge krav 4, der endvidere omfatter en opsamlingspose (14) forbundet med forlængesslangen (13), hvor én ende af opsamlingslommen (14) er forsynet med en udledningsstyringsanordning.
- 15
- 6.** Stomiaffaldsmaterialeopsamlingsanordning ifølge krav 5, hvor udledningsstyringsanordningen omfatter: en tætningslomme (16), der udgår fra opsamlingslommen (14), et selvtættende bånd (15), der er fastgjort ved tætningslommen (16), et blødt, magnetisk bånd, der er placeret ved en nedre ende af det selvtættende bånd (15), og et greb (17), der er fastgjort ved tætningslommen (16) og placeret ved en nedre ende af det bløde, magnetiske bånd (15).
- 20

DRAWINGS

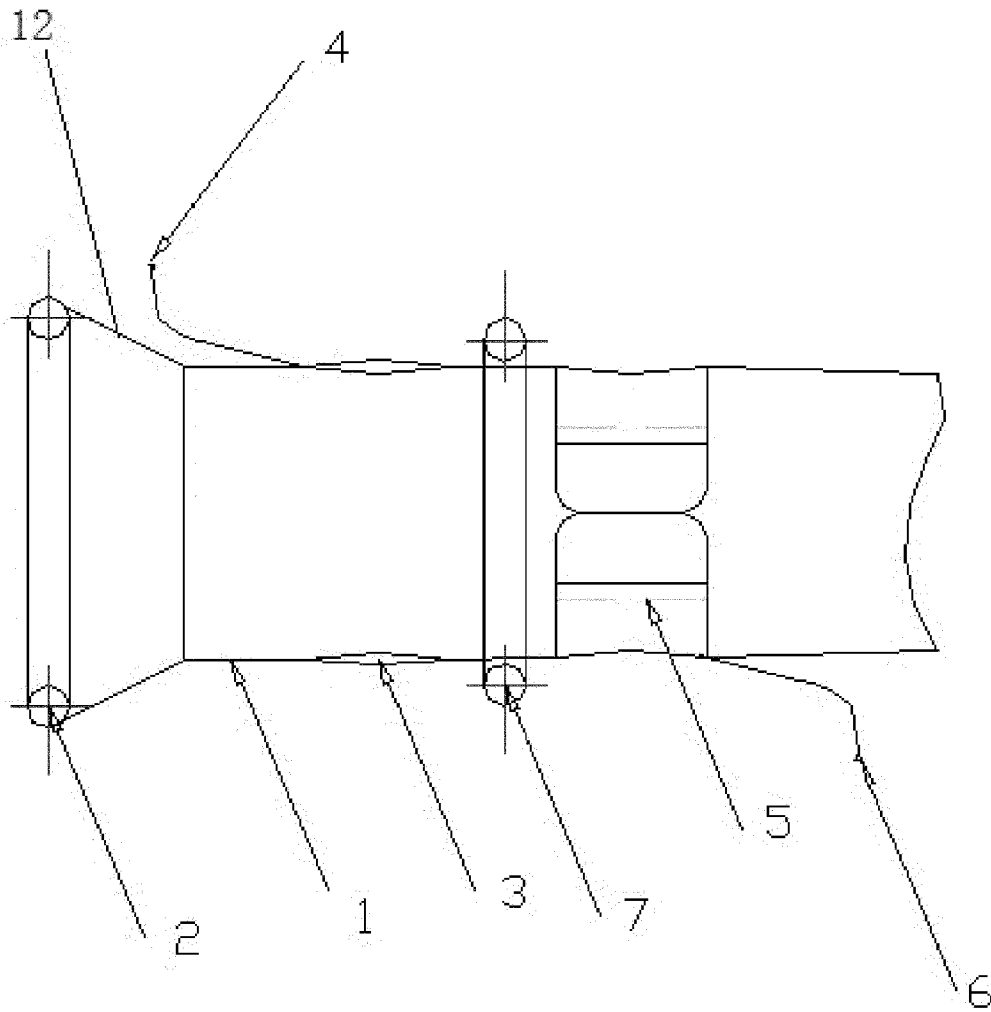

FIG. 1

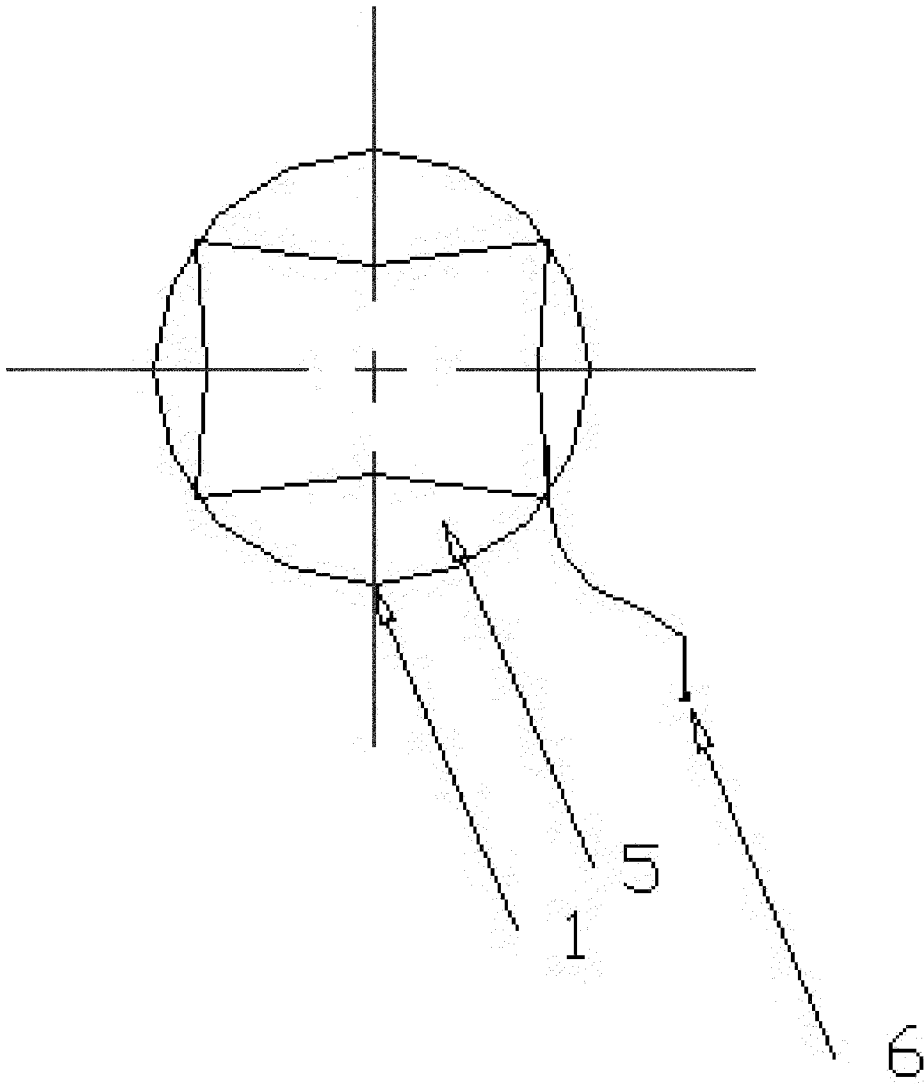

FIG. 2

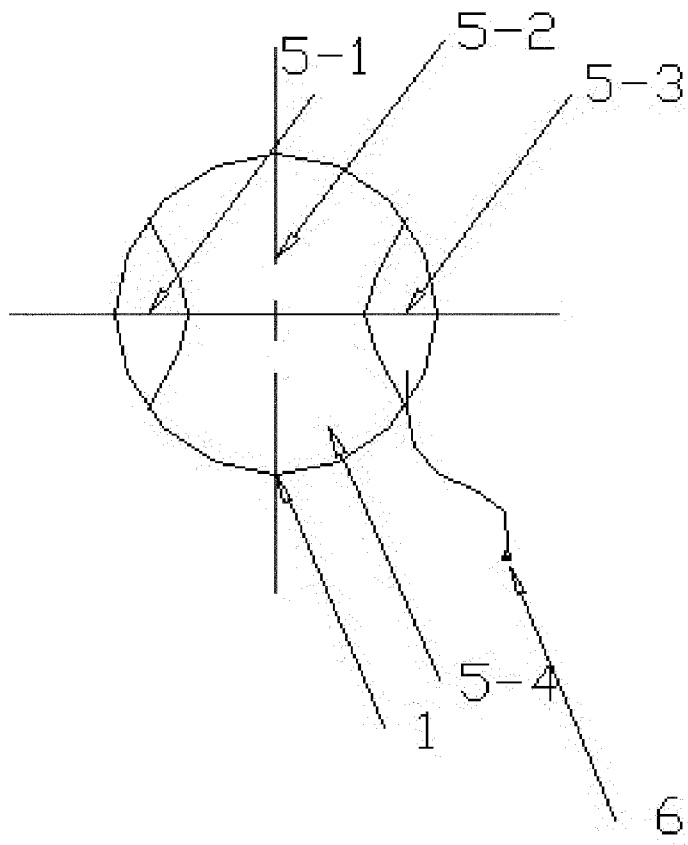

FIG. 3

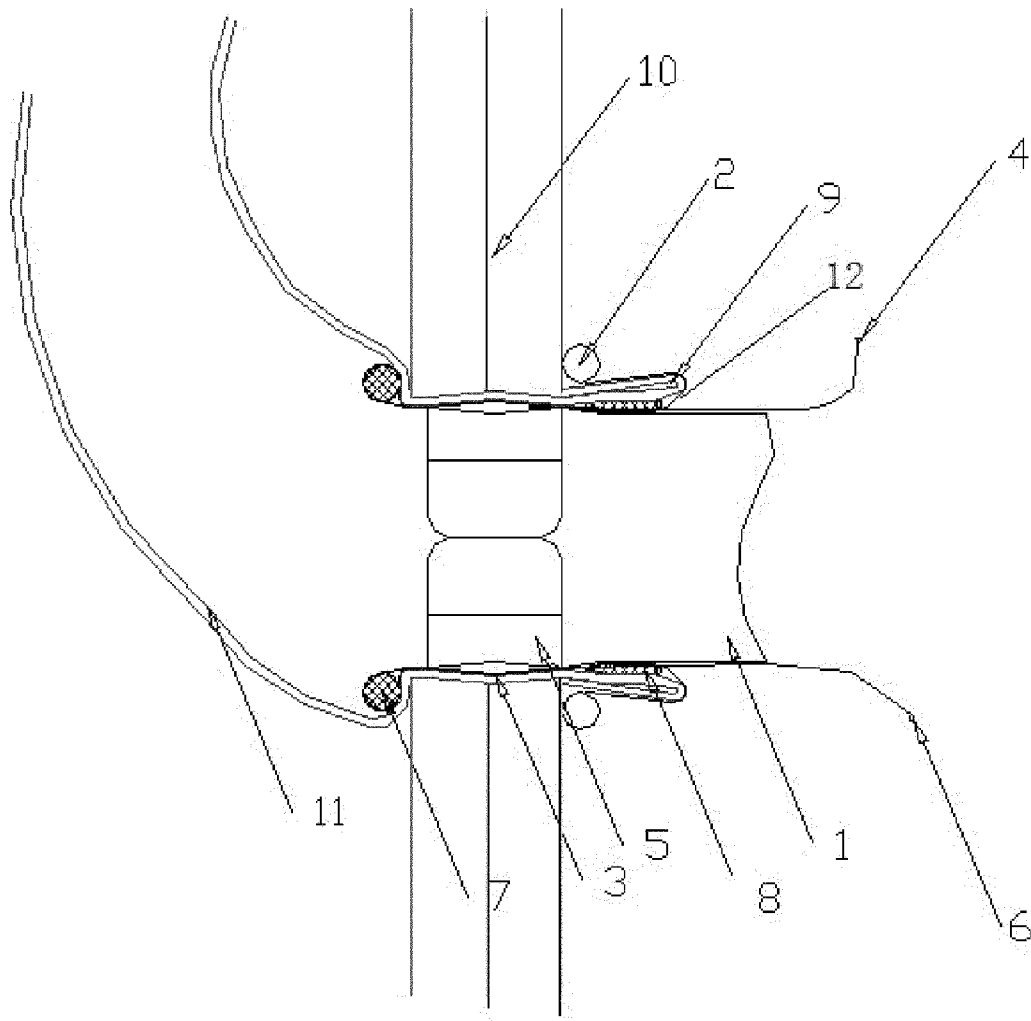

FIG. 4

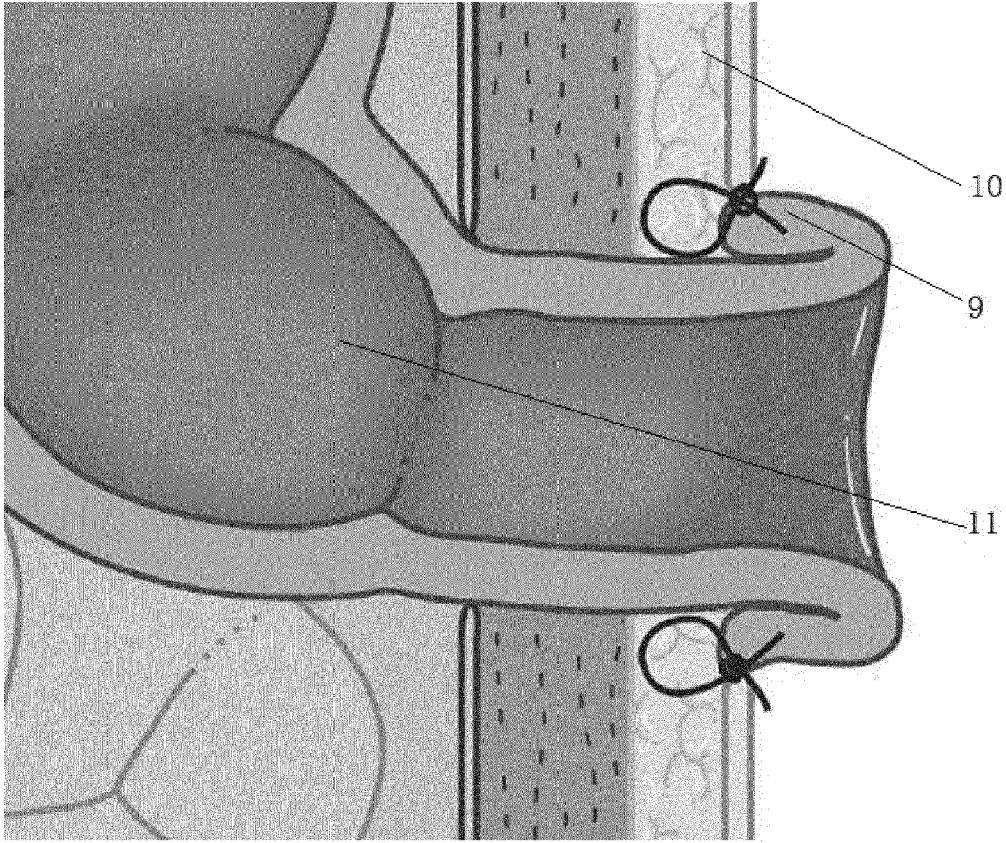

FIG. 5

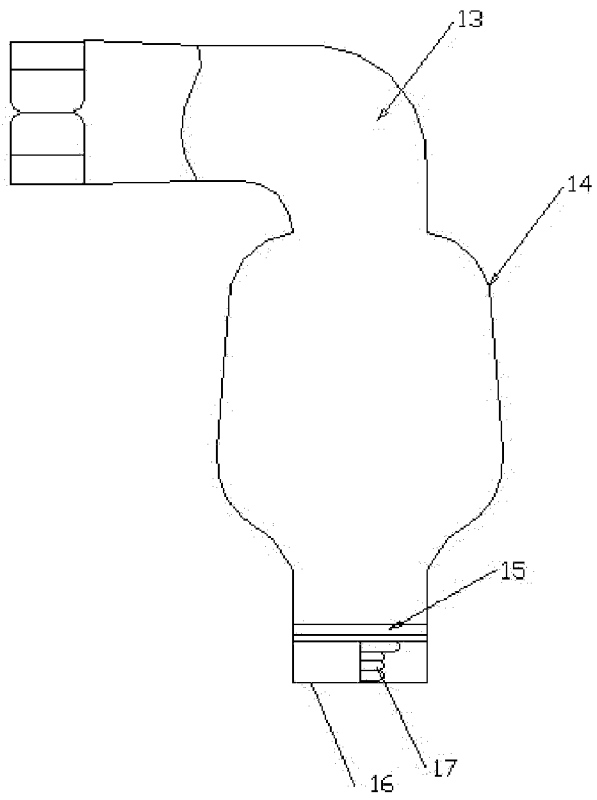

FIG. 6