



(22) Date de dépôt/Filing Date: 2003/09/26

(41) Mise à la disp. pub./Open to Public Insp.: 2005/03/26

(51) Cl.Int.⁷/Int.Cl.⁷ E04D 5/00

(71) Demandeur/Applicant:
FABRENE INC., CA

(72) Inventeurs/Inventors:
HAAS, CHRISTINE, CA;
MORAS, GUY, CA

(74) Agent: EVERITT, PETER R.

(54) Titre : SUPPORT DE COUVERTURE

(54) Title: ROOFING UNDERLAYMENT

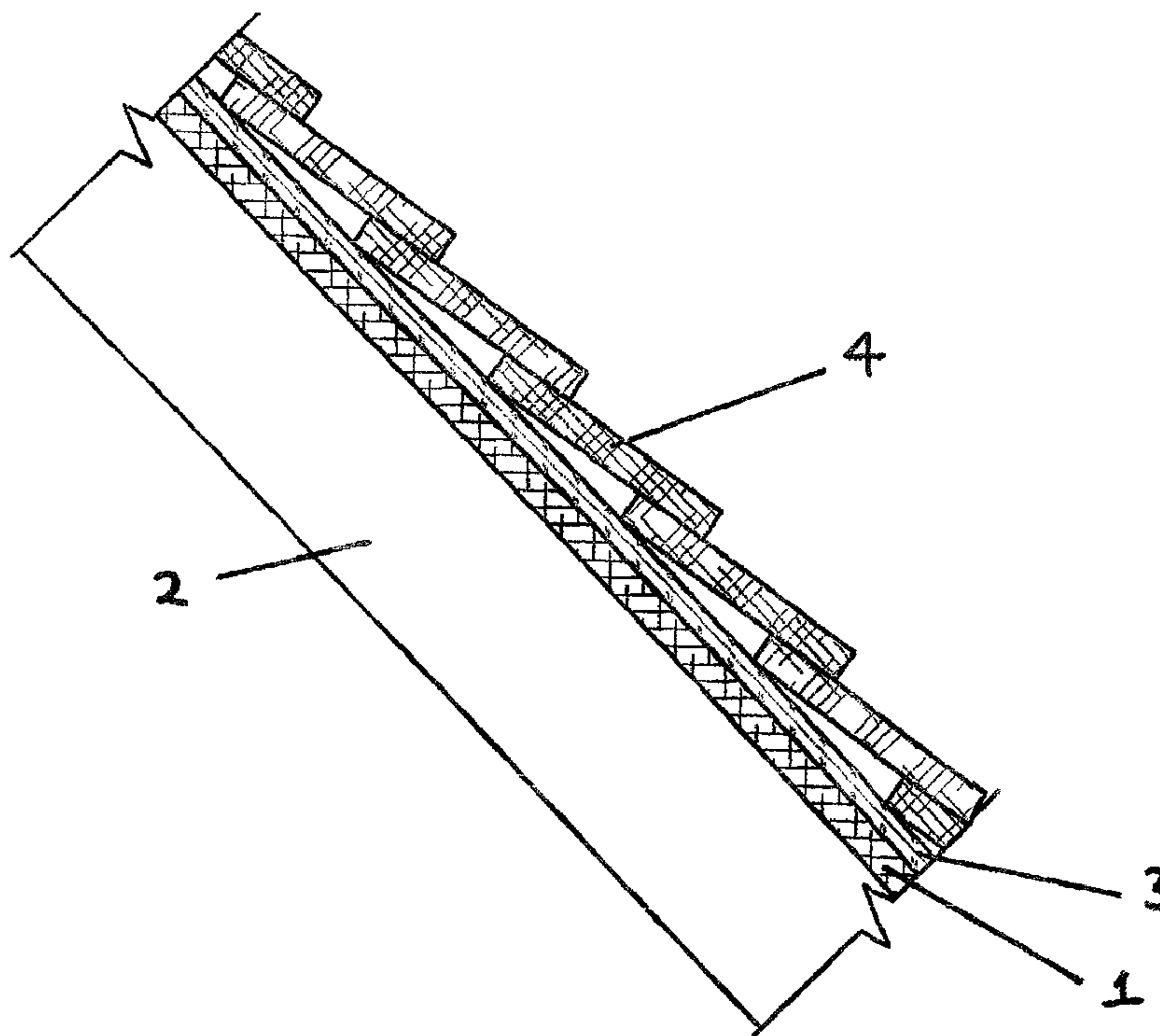

(57) Abrégé/Abstract:

A roofing underlayment for placement over a roof substrate prior to the application of shingles, tiles or other roofing materials. The underlayment comprises a sheeting material having an upper surface and a lower surface. The underlayment contains a grid that is visually identifiable from above the underlayment when the underlayment is received over the roof substrate with its lower surface adjacent to the roof substrate. The grid assists in the alignment of the underlayment with the roofing substrate during application of the underlayment to the substrate and further assists in the alignment of roofing materials applied over the underlayment.

ABSTRACT OF THE DISCLOSURE

A roofing underlayment for placement over a roof substrate prior to the application of shingles, tiles or other roofing materials. The underlayment comprises a sheeting
5 material having an upper surface and a lower surface. The underlayment contains a grid that is visually identifiable from above the underlayment when the underlayment is received over the roof substrate with its lower surface adjacent to the roof substrate. The grid assists in the alignment of the underlayment with the roofing substrate during application of the underlayment to the substrate and further assists in the alignment of
10 roofing materials applied over the underlayment.

KVAS MILLER EVERITT

CANADA

File No. 273-FAB12

TITLE: ROOFING UNDERLAYMENT

APPLICANT: FABRENE INC

TITLE: Roofing Underlayment

FIELD OF THE INVENTION

This invention relates generally to the field of roofing materials, and in particular to a
5 new and improved roofing underlayment.

BACKGROUND OF THE INVENTION

In the construction of a pitched roof, it is highly desirable from both an aesthetic and a
10 functional stand point to ensure that roofing materials are applied in a manner so that
they are "square" with the ridge of the roof, and so that they are arranged in a generally
parallel or "straight" configuration. For example, where asphalt shingles are to be
applied to a roof, alignment of the shingles in equally spaced rows that are generally
horizontal and parallel to the ridge of the roof ensures an aesthetically pleasing
15 appearance and allows the shingles to function in the manner in which they were
designed; namely, to shed water and prevent leakage. Misalignment of shingles creates
both an unattractive finished product and presents the potential for water to penetrate
through the roof and into the building. Whether the exterior roofing material is
comprised of asphalt shingles, tiles, galvanized or other metallic sheeting, wooden
20 shakes, slate or any one of a wide variety of other commonly used roofing materials,
there exists a need to apply the roofing material in an aligned and "square" fashion.

To ensure the alignment of roofing materials when applied to a roof substrate, installation personnel typically resort to one of a variety of common construction methods that enable subsequent rows of roofing materials to be aligned with previously applied rows. For example, carpenters and roofers will often mark parallel lines across the roofing substrate (which in wooden construction is typically plywood, exterior wooden sheeting, or roofing boards) through the use of a pencil, marker or chalk line. In other instances the installer may use a tape measure to physically measure the distance between respective rows of roofing materials as each row is laid down. While both of these methods may be effective, they are also labour intensive and introduce the potential for error as there is a constant requirement for individuals to take measurements and mark the position for subsequent rows of roofing materials. Failure to measure or mark accurately can result in an alignment problem.

The alignment of roofing materials can be further complicated by the fact that a liner or underlayment is commonly applied to the roof substrate prior to the application of shingles, shakes, tiles or other roofing materials. Such underlayments may be comprised of a wide variety of products including roofing paper (generally comprised of a petroleum coated cellulose product and often referred to as tar paper), roofing felt (comprised generally of asphalt saturated organic felt which may be coated or uncoated), rubber or rubberized membranes, and an equally wide variety of synthetic underlayments (both woven and extruded). Regardless of the particular form of underlayment that is

utilized, its function is essentially the same; to provide a secondary barrier to water and moisture beneath the shingles, tiles or other roofing materials and next to the roof substrate. Commonly the underlayment is applied to the roof substrate in a series of horizontal rows and is secured to the roof through the use of nails, staples or an adhesive. Once applied, the underlayment obscures the roof substrate from view making it even more difficult for a roofer to properly align the overlying roofing materials.

SUMMARY OF THE INVENTION

The invention therefore provides a product and a method that allows for the installation of shingles and other roofing materials in an aligned pattern that is "square" with the roof structure, that is cost effective, and that minimizes the potential for human error and the misalignment of roofing materials.

Accordingly, in one embodiment of the invention there is provided a roofing underlayment for placement over a roof substrate prior to the application of shingles, tiles or other roofing materials, the underlayment comprising a sheeting material having an upper surface and a lower surface, said underlayment containing a grid that is visually identifiable from above said underlayment when said underlayment is received over said roof substrate with said lower surface of said underlayment adjacent to said roof substrate, said grid assisting in the alignment of said underlayment with said roofing

substrate during application of said underlayment to said substrate and further assisting in the alignment of roofing materials applied over said underlayment.

5 In a further aspect the invention provides a roofing underlayment for placement over a roof substrate prior to the application of shingles, tiles or other roofing materials, the underlayment comprising a sheeting material having an upper surface and a lower surface, said underlayment containing a grid that is visually identifiable from above said underlayment when said underlayment is received over said roof substrate with said lower surface of said underlayment adjacent to said roof substrate, said grid comprised
10 of a series of equally spaced apart lines that are parallel to the longitudinal axis of said underlayment and a series of equally spaced apart lines that are perpendicular to the longitudinal axis of said underlayment, said grid assisting in the alignment of said underlayment with said roofing substrate during application of said underlayment to said substrate and further assisting in the alignment of roofing materials applied over said
15 underlayment.

In yet a further aspect the invention provides a roofing underlayment for placement over a roof substrate prior to the application of shingles, tiles or other roofing materials, the underlayment comprising a sheeting material having an upper surface and a lower
20 surface, said underlayment containing a grid that is visually identifiable from above said underlayment when said underlayment is received over said roof substrate with said

lower surface of said underlayment adjacent to said roof substrate, said grid comprised of a series of spaced apart and parallel lines extending over at least a portion of said upper surface of said underlayment, said grid assisting in the alignment of said underlayment with said roofing substrate during application of said underlayment to said substrate and further assisting in the alignment of roofing materials applied over said underlayment.

The invention also provides a roofing underlayment for placement over a roof substrate prior to the application of shingles, tiles or other roofing materials, the underlayment comprising a sheeting material having an upper surface and a lower surface, said underlayment containing a grid that is visually identifiable when said underlayment is received over said roofing substrate with said lower surface of said underlayment adjacent to said substrate, said grid comprised of a series of spaced apart longitudinal lines that are parallel to the longitudinal axis of said underlayment and a series of spaced apart perpendicular lines that are perpendicular to the longitudinal axis of said underlayment, said longitudinal and said perpendicular lines coloured to distinguish said lines from said sheeting material.

In a further aspect the invention concerns a roofing underlayment for placement over a roof substrate prior to the application of shingles, tiles or other roofing materials, the underlayment comprising a sheeting material having an upper surface and a lower

surface, said underlayment containing a grid that is visually identifiable when said underlayment is received over said roofing substrate with said lower surface of said underlayment adjacent to said substrate, said grid comprised of a series of spaced apart longitudinal lines that are parallel to the longitudinal axis of said underlayment and a
5 series of spaced apart perpendicular lines that are perpendicular to the longitudinal axis of said underlayment, said longitudinal lines being of at least a first colour contrasting to the colour of said underlayment, said perpendicular lines being of at least a second colour contrasting to the colour of said underlayment.

10 Further aspects and advantages of the invention will become apparent from the following description taken together with the accompanying drawings.

BRIEF DESCRIPTION OF THE DRAWINGS

15 For a better understanding of the present invention, and to show more clearly how it may be carried into effect, reference will now be made, by way of example, to the accompanying drawings which show the preferred embodiments of the present invention in which:

20 Figure 1 is a side sectional view through a portion of a typical pitched roof showing one embodiment of the present invention;

Figure 2 is an upper side perspective view of a pitched roof having a series of horizontal rows of a roof underlayment applied thereto;

5 Figure 3 is an upper perspective view of a roll of roofing underlayment according to one embodiment of the present invention;

Figure 4 is an upper perspective view of a roll of roofing underlayment according to a second embodiment of the present invention;

10 Figures 5A, 5B and 5C are upper perspective views of rolls of roofing underlayment according to a third, fourth and fifth embodiment of the present invention;

15 Figure 6 is a front view of a portion of a pitched roof showing the application of a roofing underlayment in accordance with a preferred embodiment of the present invention and as used in association with asphalt shingles;

Figure 7 is a magnified detail view of a portion of a roofing underlayment according to an embodiment of the present invention where the underlayment is formed from a woven scrim;

20

Figure 8 is a magnified detail side sectional view of a portion of a roofing underlayment according to an embodiment of the present invention where the upper surface of the underlayment has a grid pattern embossed thereon;

5 Figure 9 is a magnified detail side sectional view of a portion of a roofing underlayment according to an embodiment of the present invention where the upper surface of the underlayment includes a grid pattern formed from a series of tapes, yarns or filaments.

DESCRIPTION OF THE PREFERRED EMBODIMENT

10

The present invention may be embodied in a number of different forms. However, the specification and drawings that follow describe and disclose only some of the specific forms of the invention and are not intended to limit the scope of the invention as defined in the claims that follow herein.

15

The typical structure of a standard pitched roof (as constructed in wood framed buildings) is shown in cross section in Figure 1. In general such roofs are comprised of a wooden substrate 1 fastened to a series of trusses or rafters 2. A roofing underlayment 3 is commonly laid over substrate 1. Thereafter roofing materials 4 are applied to form the finished roof. In most instances substrate 1 would be comprised of plywood, exterior sheathing, or a series of wooden boards. However, it will be appreciated that the

20

scope and application of the present invention will not be limited to a particular form of substrate. Similarly, while roofing materials 4 may be comprised of asphalt shingles as shown in Figure 1, the roofing material may equally be any one of a wide variety of exterior roofing products, including clay or cement tiles, wooden shakes, metal roofing materials, slate, etc. As in the case of substrate 1, the scope of the present invention is not limited to any particular roofing material.

It is expected that in most cases underlayment 3 will be comprised of a relatively thin and flexible material formed into rolls (see Figures 3, 4 and 5) that may be cut to length as necessary. While underlayment 3 may be manufactured to practically any desired dimension, for handling and transportation purposes rolls of a width of between 30 and 80 inches are most desirable. Where rolls of this size range are utilized a series of horizontally oriented rows of underlayment will be applied to the roof in order to fully cover substrate 1. Preferably the rows of underlayment material are applied beginning along the lower edge of the roof working toward the top such that each subsequent row that is higher up on the roof overlaps the adjacent lower row to allow any moisture that may come into contact with the underlayment to be shed as it flows downwardly along the pitch of the roof. In other embodiments of the invention substantially larger rolls of material could be manufactured such that a single sheet of underlayment is capable of covering the entire exterior surface of substrate 1. Alternatively, the substrate could be formed into a rigid or semi-rigid sheeting material that is applied to the roof in a manner

similar to the application of the substrate material.

The composition and structure of underlayment 3 may vary substantially depending upon the particular application in question. The underlayment may range from a
5 common tar paper or roofing felt structure, to a plastic or rubberized or PVC ice and water shield, to a single ply thermoplastic (for example polyolefin) membrane, to a high strength woven product comprised of a series of woven tapes, yarns and/or filaments (identified generally as 12 in Figure 7). The underlayment may also be coated on one or both sides to enhance abrasion resistance, to increase strength and water resistance,
10 and/or to present a slip resistant surface. Depending upon the environment within which the roof structure is located, the type of roofing material to be applied over the underlayment, the required useful life of the roof, and considering differences in costs, it may be desirable to use one particular composition and structure of underlayment over and above the others. It will be appreciated from a complete understanding of the
15 present invention that the preferred embodiment of the invention is not limited to one form of underlayment or a particular method of manufacture.

In accordance with a preferred embodiment of the invention underlayment 3 is comprised of a sheeting or sheet-like material having an upper surface 5 and a lower
20 surface 6 that is received over roof substrate 1. Typically underlayment 3 is secured to substrate 1 through the use of nails, staples or an adhesive. Of particular importance to

the invention is the fact that at least the upper surface 6 of underlayment 3 contains a visually identifiable grid 7. Grid 7 assists in both the alignment of the underlayment with the roof substrate (and with subsequent rows of underlayment) during application of the underlayment to the roof, and also assists in the subsequent alignment of roofing materials that are applied over the underlayment. It will be understood that there are a variety of manners in which grid 7 may be applied or adhered to underlayment 3, including printing or embossing the grid upon upper surface 6 of the underlayment. Where grid 7 is embossed on the surface of underlayment 3 the effect may be the formation of small linear indentations 11 across the surface of the underlayment (see Figure 8). Grid 7 may also be printed, embossed or otherwise applied to both upper surface 5 and lower surface 6 allowing either of the outer surfaces of the underlayment to be placed adjacent to roof substrate 1. Where grid 7 is embossed on underlayment 3 the embossed surface will also tend to exhibit anti-skid characteristics further enhancing the characteristics of the product.

15

In alternate embodiments of the invention, grid 7 may be comprised of a series of yarns, tapes and/or filaments 10 that are woven into the underlayment where the underlayment is a woven scrim (See generally Figure 7). The yarns, tapes and/or filaments 10 are preferably coloured a contrasting colour to the scrim and may be superimposed or adjacent to the yarns, tapes and/or filaments 12 of the scrim. Alternatively yarns, tapes and/or filaments 10 may be otherwise adhered to either the upper and/or the lower

20

surface of the underlayment (for example see Figure 9) through the use of an adhesive, or during a coating process where the underlayment is a coated product.

In one of the preferred embodiments of the invention grid 7 is comprised of a series of
5 equally spaced apart lines 8 that are parallel to the longitudinal axis of the sheeting material from which the underlayment is made (see Figure 3). Alternately, grid 7 may be comprised of a series of equally spaced apart lines 9 that are perpendicular to the longitudinal axis of the sheeting material (see Figure 4). In yet a third embodiment grid 7 may be comprised of both a series of equally spaced apart lines 8 that are parallel to
10 the longitudinal axis of the sheeting material, and a series of equally spaced apart lines 9 that are perpendicular to the longitudinal axis of the sheeting material (see Figures 5A, 5B and 5C).

Regardless of the particular grid structure that is used, the lines that comprise grid 7
15 must be visually identifiable, and to that extent they are preferably of a colour other than that of the sheeting material from which the underlayment is constructed (or other than the coating material where the underlayment is a coated product). For example, where the sheeting material of underlayment 3 is white or a light colour, grid 7 may be black, green, red or some other contrasting colour making the lines of the grid clearly
20 identifiable upon the surface of the product. In addition, the lines comprising grid 7 may in some fashion alternate in colour between a first colour and a second colour to present

a further visual identification and distinction between adjacent or groups of lines. In these regards, one variation of grid 7 that could be utilized comprises a one inch spacing between lines that are parallel to the longitudinal axis of the underlayment with the lines alternating in colour between green and black. In another variation, grid 7 may be
5 comprised of lines that are parallel to the longitudinal axis of the underlayment and that are spaced apart by one inch increments, and lines that are perpendicular to the longitudinal axis of the underlayment and also spaced apart in one inch increments. The longitudinally oriented lines may be black with the perpendicular lines green, presenting a visual distinction between the rows of lines that will effectively be oriented vertically
10 and horizontally when underlayment 3 is placed in a generally horizontal configuration across roof substrate 1. The alternating colours of the lines forming in grid 7 helps to present a visual distinction between adjacent lines and assists in the alignment of underlayment 3 and roofing materials 4.

15 Further possible variations of grid 7 are shown in Figures 5A and 5B. In the embodiment shown in Figure 5A grid 7 is comprised of lines that are parallel to the longitudinal axis of the underlayment with adjacent parallel lines alternating in colour. The grid is further comprised of lines that are perpendicular to the longitudinal axis of the underlayment with adjacent perpendicular lines alternating in colour.

20

In Figure 5B, an embodiment is shown wherein grid 7 is comprised of a series of lines parallel to the longitudinal axis of the underlayment and equally spaced apart in one inch increments. The longitudinally oriented lines alternate in colour in six inch blocks creating groups of lines of like colours that alternate every six inches. The grid further comprises a series of lines perpendicular to the longitudinal axis of the underlayment and also spaced apart in one inch increments. As in the case of the longitudinally oriented lines, the perpendicular lines alternate in colour in six inch blocks. The grouping of the perpendicular and parallel lines in six inch blocks, and the further subdividing of those six inch blocks into one inch segments, has been found to provide the roofing installer with a visually identifiable grid that allows for the measurement of larger distances through counting six inch blocks, while at the same time providing for relatively precise measurement and alignment through reference to individual lines spaced apart in one inch increments.

It will of course be appreciated that while the embodiment depicted in Figure 5B contemplates a line spacing of one inch with six inch groupings in both the longitudinal and perpendicular directions, the individual line spacing, and/or the grouping of lines of a common colour, could vary depending upon the particular end use of the product. For example, when applying particular types of roofing materials it may be desirable to use an alternate line spacing and/or an alternate grouping of lines of different colours to more closely conform to the physical dimensions of the particular roofing materials in

question. In some cases the line spacing may be as low as 1/8 inch while in other cases a spacing as high as 24 inches may be desirable. Further, where both vertical and horizontal lines are utilized, the spacing of the horizontal lines may be different than that of the vertical lines. For example, it may be advantageous for the horizontal lines to have an incremental spacing of one inch whereas the vertically oriented lines may be spaced apart at intervals of 12 inches. It should also be noted that grid 7 may be comprised of lines that are solid, broken or patterned (for example small dots, squares, etc.).

10 Through the utilization of a roofing underlayment as described herein, it will be appreciated that a roofer is provided with a means by which the underlayment itself can be easily aligned with the roof substrate, and in particular the ridge of the roof. Where the underlayment is applied in a series of horizontal rows, the roofing installer is able to quickly and easily align adjacent rows with one another so that they maintain their horizontal attitude and to ensure that each subsequent row positioned higher up on the roof is both parallel to the lower adjacent row and over laps the lower row by sufficient degree. Once the underlayment has been applied to the roof the grid pattern that is visually identifiable thereon presents the roofer with an ability to quickly and accurately align shingles or other roofing materials with both one another and with the roof. An example showing how underlayment 3 may be used to assist in the alignment of shingles is shown in Figure 6.

It will thus be appreciated that utilization of underlayment 3 will remove the necessity for roofers to use chalk lines, straight edges, measuring tapes and other implements to ensure alignment of roofing materials as they are applied. The invention also removes the need for measuring, and the associated potential for error in either failing to measure properly or failing to mark a measurement properly upon the roof. The roofer need only align the shingles or the roofing materials with the grid pattern upon underlayment 3 to ensure that the roofing materials are installed in a horizontal and parallel configuration with adequate overlap. Where the underlayment exhibits anti-skid characteristics its application over a roof substrate will also present an inherently safer work surface for roofing installers.

It is to be understood that what has been described are the preferred embodiments of the invention and that it may be possible to make variations to these embodiments while staying within the broad scope of the invention. Some of these variations have been discussed while others will be readily apparent to those skilled in the art. For example, while the grid patterns discussed and shown in the attached Figures represent what are believed to be some of the most likely practical embodiments of the invention, a variety of other grid patterns could equally be utilized, including grid patterns that are comprised of non-uniformly spaced apart lines.

20

WE CLAIM:

1. A roofing underlayment for placement over a roof substrate prior to the application of shingles, tiles or other roofing materials, the underlayment comprising a sheeting material having an upper surface and a lower surface, said underlayment containing a grid that is visually identifiable from above said underlayment when said underlayment is received over said roof substrate with said lower surface of said underlayment adjacent to said roof substrate, said grid assisting in the alignment of said underlayment with said roofing substrate during application of said underlayment to said substrate and further assisting in the alignment of roofing materials applied over said underlayment.
2. The underlayment as claimed in claim 1 wherein said underlayment is a thin rolled material.
3. The underlayment as claimed in claim 1 wherein said grid is printed on said upper surface of said underlayment.
4. The underlayment as claimed in claim 1 wherein said grid is embossed on said upper surface of said underlayment.

5. The underlayment as claimed in claim 1 wherein said grid is comprised of a series of equally spaced apart lines that are parallel to the longitudinal axis of said underlayment.
- 5 6. The underlayment as claimed in claim 1 wherein said grid is comprised of a series of equally spaced apart lines that are perpendicular to the longitudinal axis of said underlayment.
- 10 7. The underlayment as claimed in claim 1 wherein grid is comprised of a series of equally spaced apart lines that are parallel to the longitudinal axis of said underlayment and a series of equally spaced apart lines that are perpendicular to the longitudinal axis of said underlayment.
- 15 8. The underlayment as claimed in claim 5 wherein adjacent lines alternate in colour between a first colour and a second colour.
9. The underlayment as claimed in claim 6 wherein adjacent lines alternate in colour between a first colour and a second colour.
- 20 10. The underlayment as claimed in claim 7 wherein said lines that are parallel to said longitudinal axis of said underlayment are of a first colour and said lines

that are perpendicular to said longitudinal axis of said underlayment are of a second colour.

- 5
11. The underlayment as claimed in claim 1 wherein said sheeting material is tar paper, roofing felt, rubber, extruded plastic, woven or extruded polyolefin or PVC.
12. The underlayment as claimed in claim 1 wherein said sheeting material is rigid.
- 10
13. The underlayment as claimed in claim 1 wherein said grid is comprised of a series of yarns, tapes or filaments.
14. The underlayment as claimed in claim 13 wherein said underlayment is a first colour and said yarns, tapes or filaments are a contrasting colour.
- 15
15. The underlayment as claimed in claim 14 wherein said underlayment is a woven scrim and said yarns, tapes or filaments are woven into said scrim.
16. The underlayment as claimed in claim 14 wherein said yarns, tapes or filaments are adhered to said upper surface of said scrim.
- 20

17. The underlayment as claimed in claim 14 wherein at least said upper surface of said sheeting material is coated, said yarns, tapes or filaments embedded within said coating on said upper surface.
- 5 18. The underlayment as claimed in claim 1 wherein said grid is comprised of a series of solid, broken or patterned lines.
- 10 19. A roofing underlayment for placement over a roof substrate prior to the application of shingles, tiles or other roofing materials, the underlayment comprising a sheeting material having an upper surface and a lower surface, said underlayment containing a grid that is visually identifiable from above said underlayment when said underlayment is received over said roof substrate with said lower surface of said underlayment adjacent to said roof substrate, said grid comprised of a series of equally spaced apart lines that are parallel to the longitudinal axis of said underlayment and a series of equally spaced apart lines that are perpendicular to the longitudinal axis of said underlayment, said grid assisting in the alignment of said underlayment with said roofing substrate during application of said underlayment to said substrate and further assisting in the alignment of roofing materials applied over said underlayment.

20

20. The underlayment as claimed in claim 19 wherein said lines that are parallel to said longitudinal axis of said underlayment are of a first colour, said lines that are perpendicular to said longitudinal axis of said underlayment are of a second colour, and said sheeting material is of a third colour.

5

21. A roofing underlayment for placement over a roof substrate prior to the application of shingles, tiles or other roofing materials, the underlayment comprising a sheeting material having an upper surface and a lower surface, said underlayment containing a grid that is visually identifiable from above said underlayment when said underlayment is received over said roof substrate with said lower surface of said underlayment adjacent to said roof substrate, said grid comprised of a series of spaced apart and parallel lines extending over at least a portion of said upper surface of said underlayment, said grid assisting in the alignment of said underlayment with said roofing substrate during application of said underlayment to said substrate and further assisting in the alignment of roofing materials applied over said underlayment.

10

15

22. A roofing underlayment for placement over a roof substrate prior to the application of shingles, tiles or other roofing materials, the underlayment comprising a sheeting material having an upper surface and a lower surface, said underlayment containing a grid that is visually identifiable when said

20

- underlayment is received over said roofing substrate with said lower surface of said underlayment adjacent to said substrate, said grid comprised of a series of spaced apart longitudinal lines that are parallel to the longitudinal axis of said underlayment and a series of spaced apart perpendicular lines that are perpendicular to the longitudinal axis of said underlayment, said longitudinal and said perpendicular lines coloured to distinguish said lines from said sheeting material.
- 5
23. The underlayment as claimed in claim 22 wherein said longitudinal lines are spaced apart in pre-defined increments and arranged in blocks of lines of like colour, said grid including a plurality of said blocks of longitudinal lines with adjacent blocks of longitudinal lines alternating in colour.
- 10
24. The underlayment as claimed in claim 22 wherein said perpendicular lines are spaced apart in pre-defined increments and arranged in blocks of lines of like colour, said grid including a plurality of said blocks of perpendicular lines with adjacent blocks of perpendicular lines alternating in colour.
- 15
25. The underlayment as claimed in claim 22 wherein said longitudinal lines are spaced apart in pre-defined increments and arranged in blocks of lines of like colour and said perpendicular lines are spaced apart in pre-defined increments
- 20

and arranged in blocks of lines of like colour, said grid including a plurality of said blocks of longitudinal lines and a plurality of said blocks of perpendicular lines, said adjacent blocks of longitudinal lines alternating in colour and said adjacent blocks of perpendicular lines alternating in colour.

5

26. A roofing underlayment for placement over a roof substrate prior to the application of shingles, tiles or other roofing materials, the underlayment comprising a sheeting material having an upper surface and a lower surface, said underlayment containing a grid that is visually identifiable when said underlayment is received over said roofing substrate with said lower surface of said underlayment adjacent to said substrate, said grid comprised of a series of spaced apart longitudinal lines that are parallel to the longitudinal axis of said underlayment and a series of spaced apart perpendicular lines that are perpendicular to the longitudinal axis of said underlayment, said longitudinal lines being of at least a first colour contrasting to the colour of said underlayment, said perpendicular lines being of at least a second colour contrasting to the colour of said underlayment.

10

15

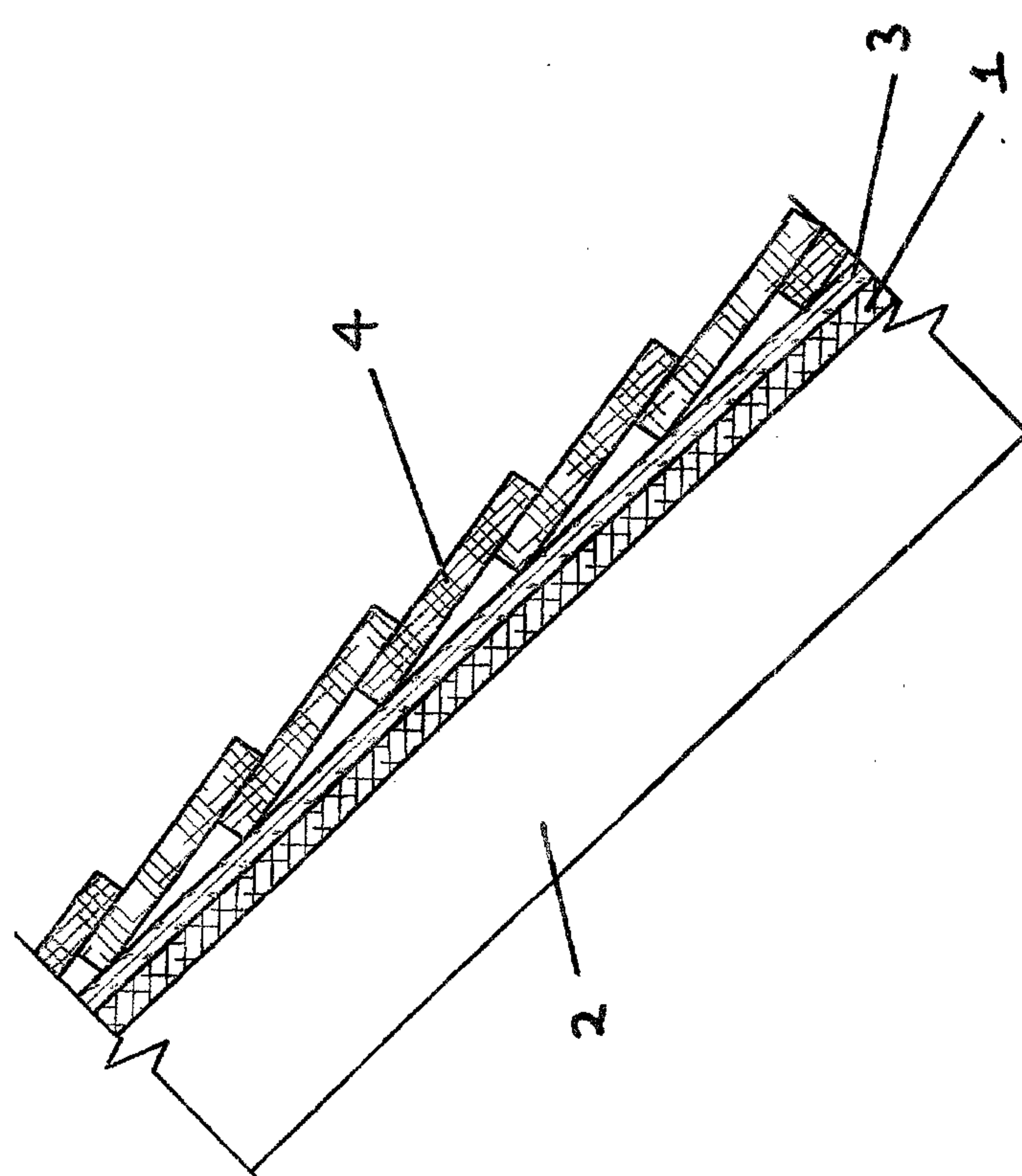

FIG. 1

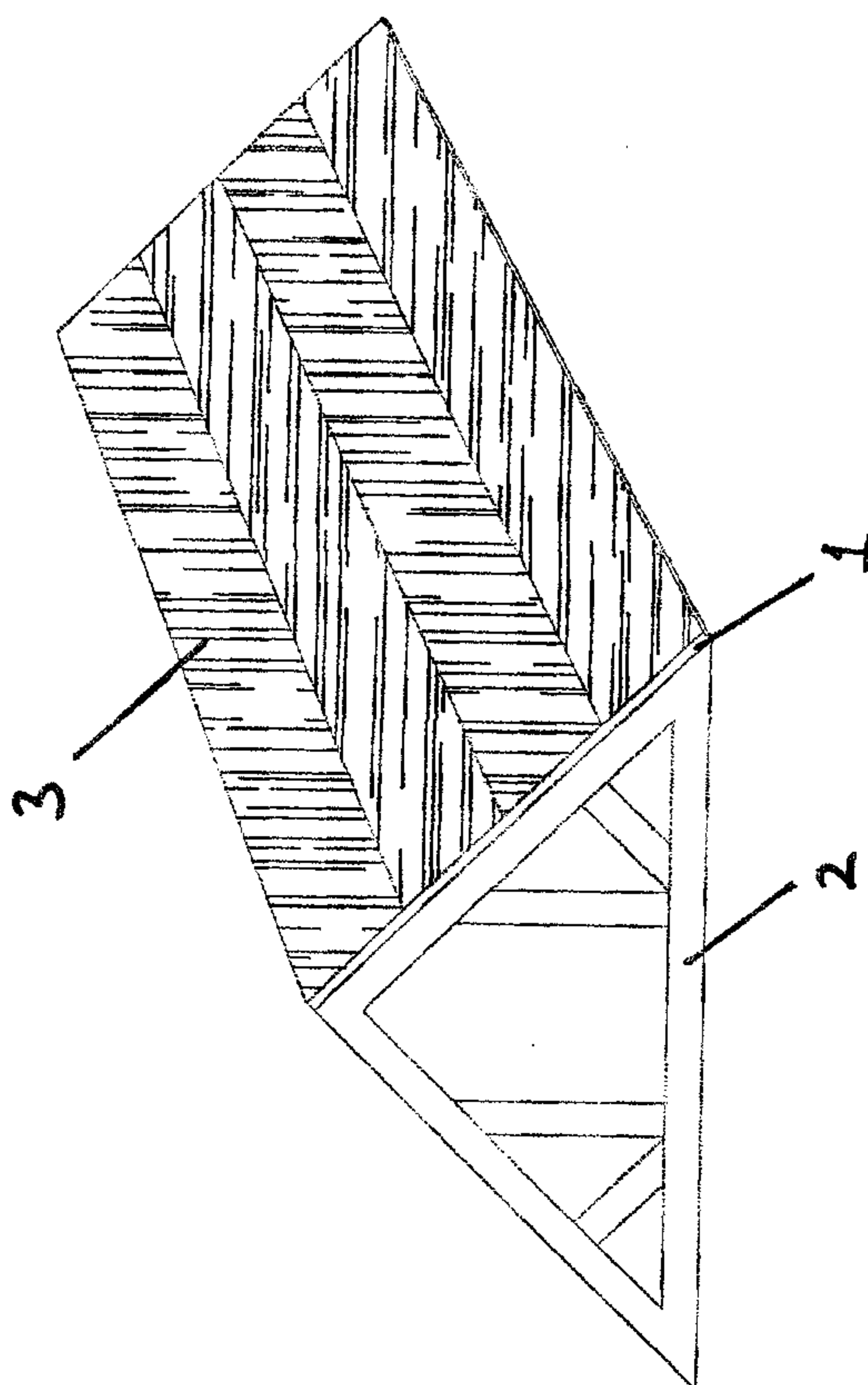

FIG. 2

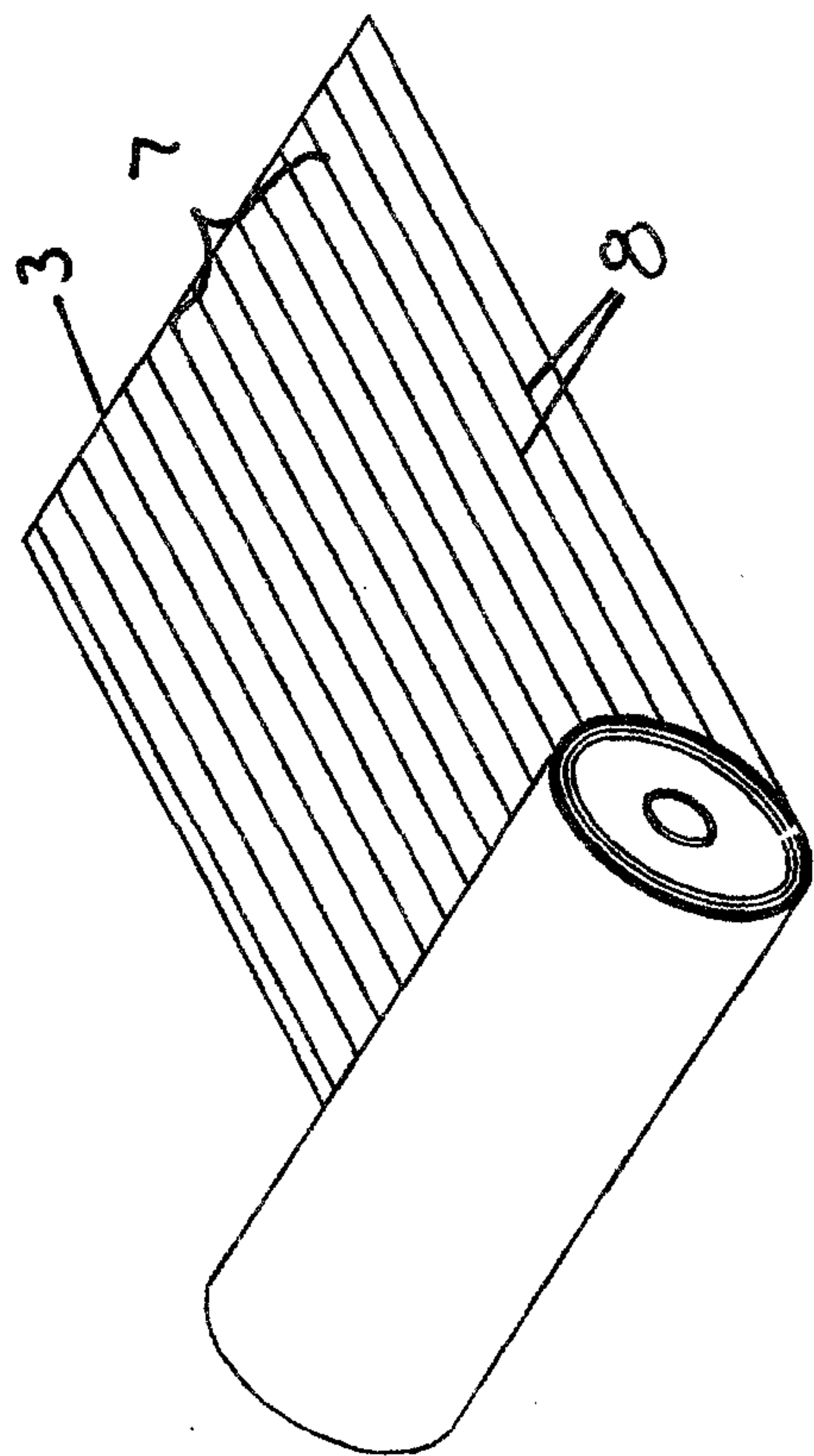

FIG. 3

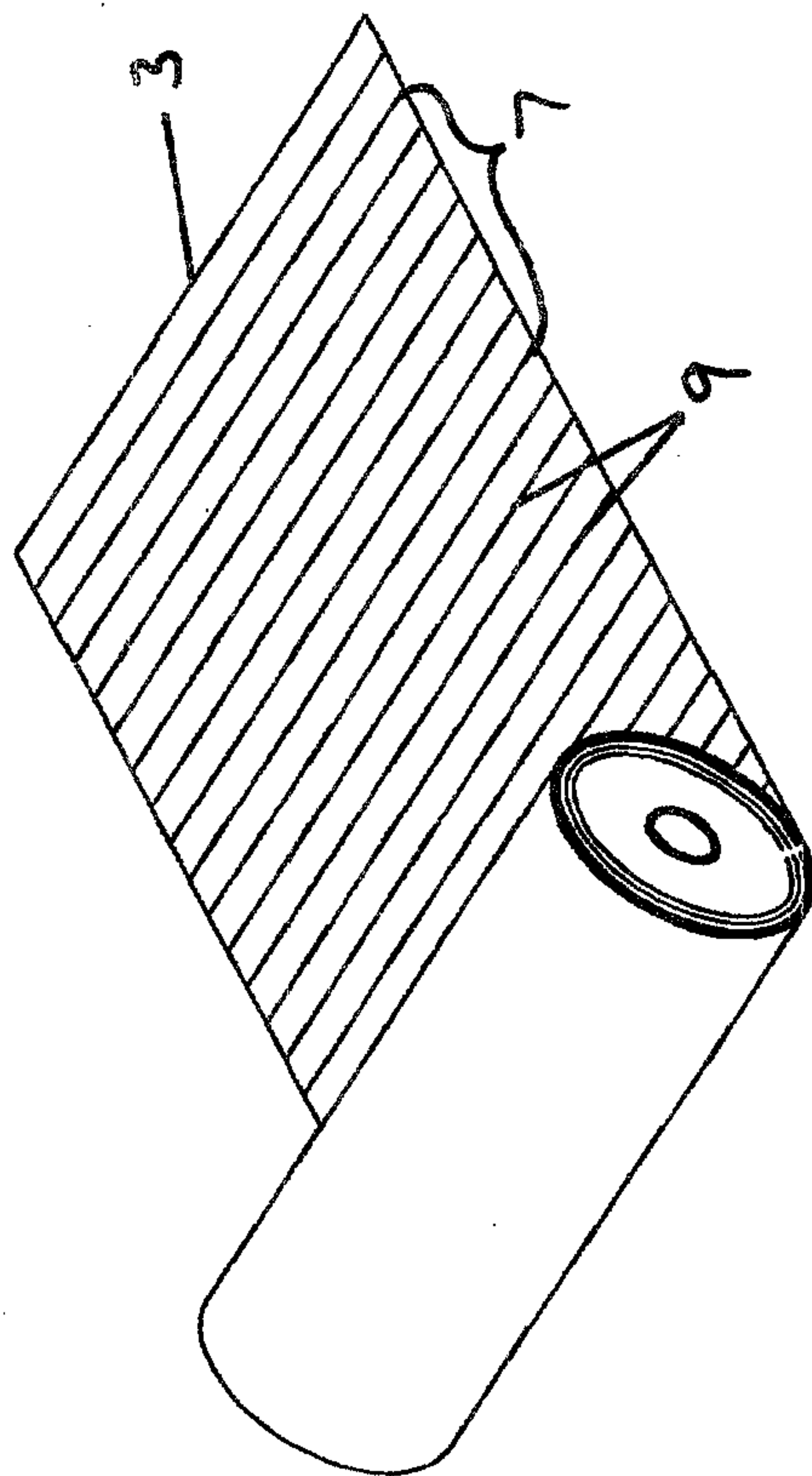

FIG. 4

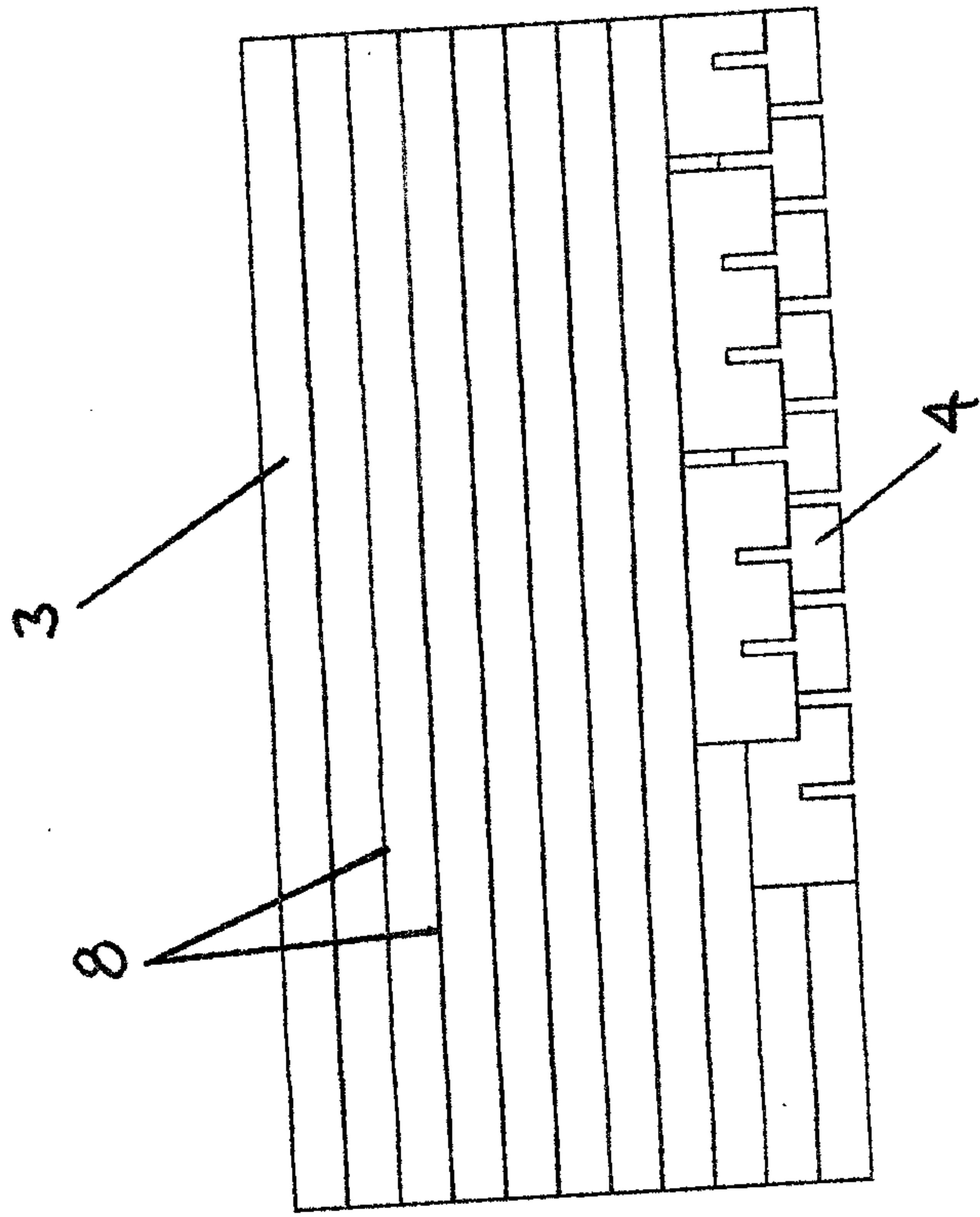

FIG. 6

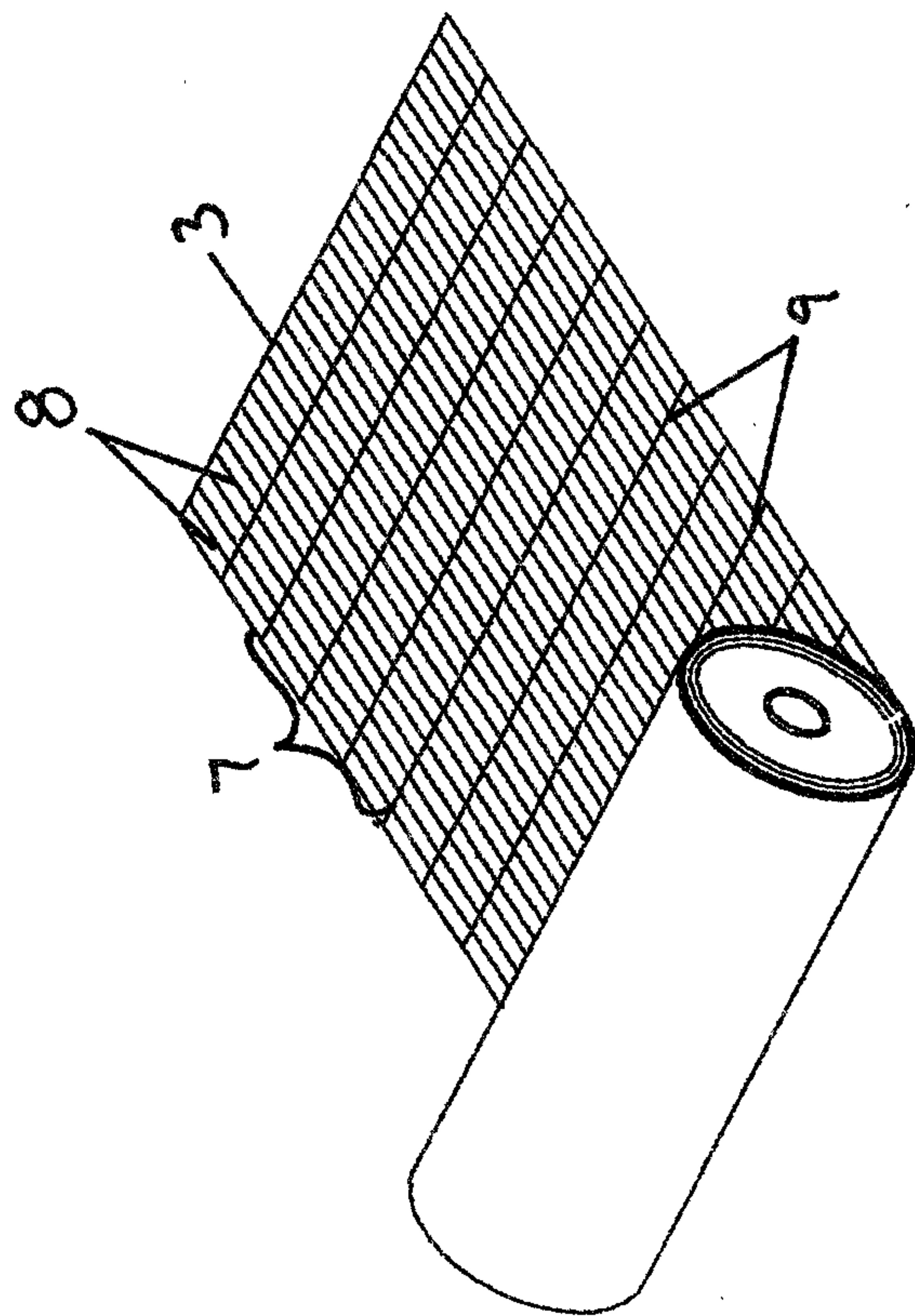

FIG. 5A

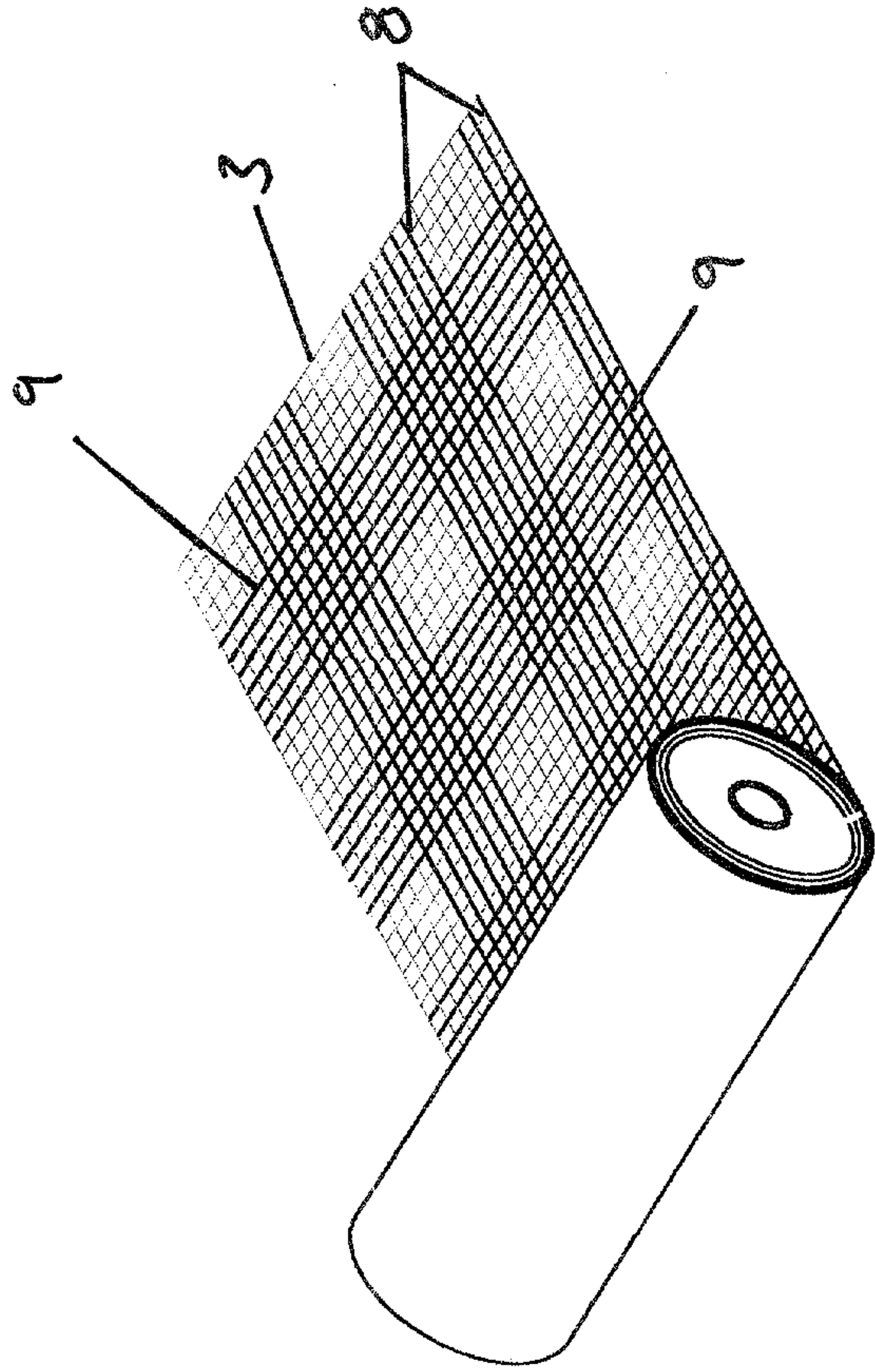

FIG. 5C

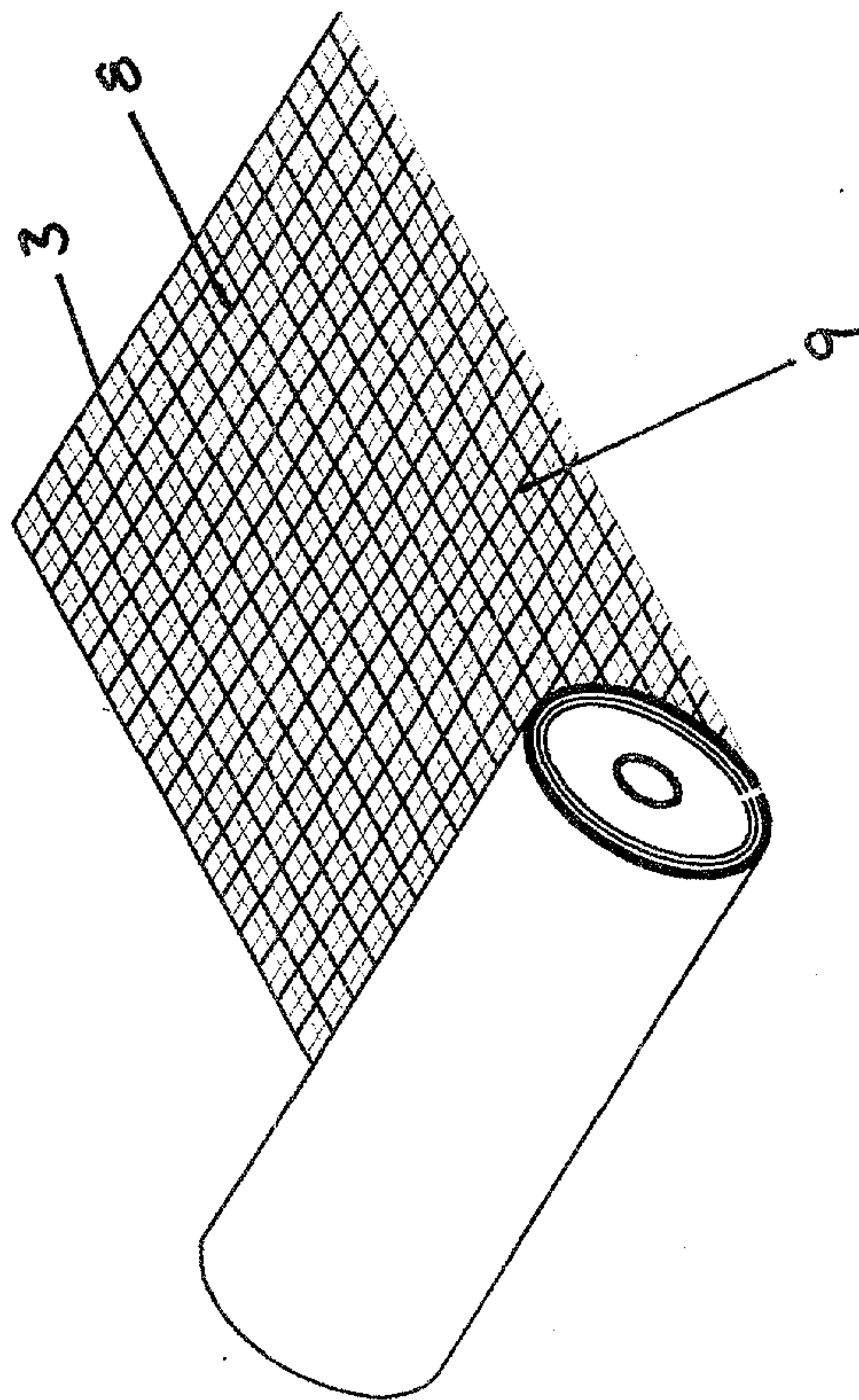

FIG. 5B

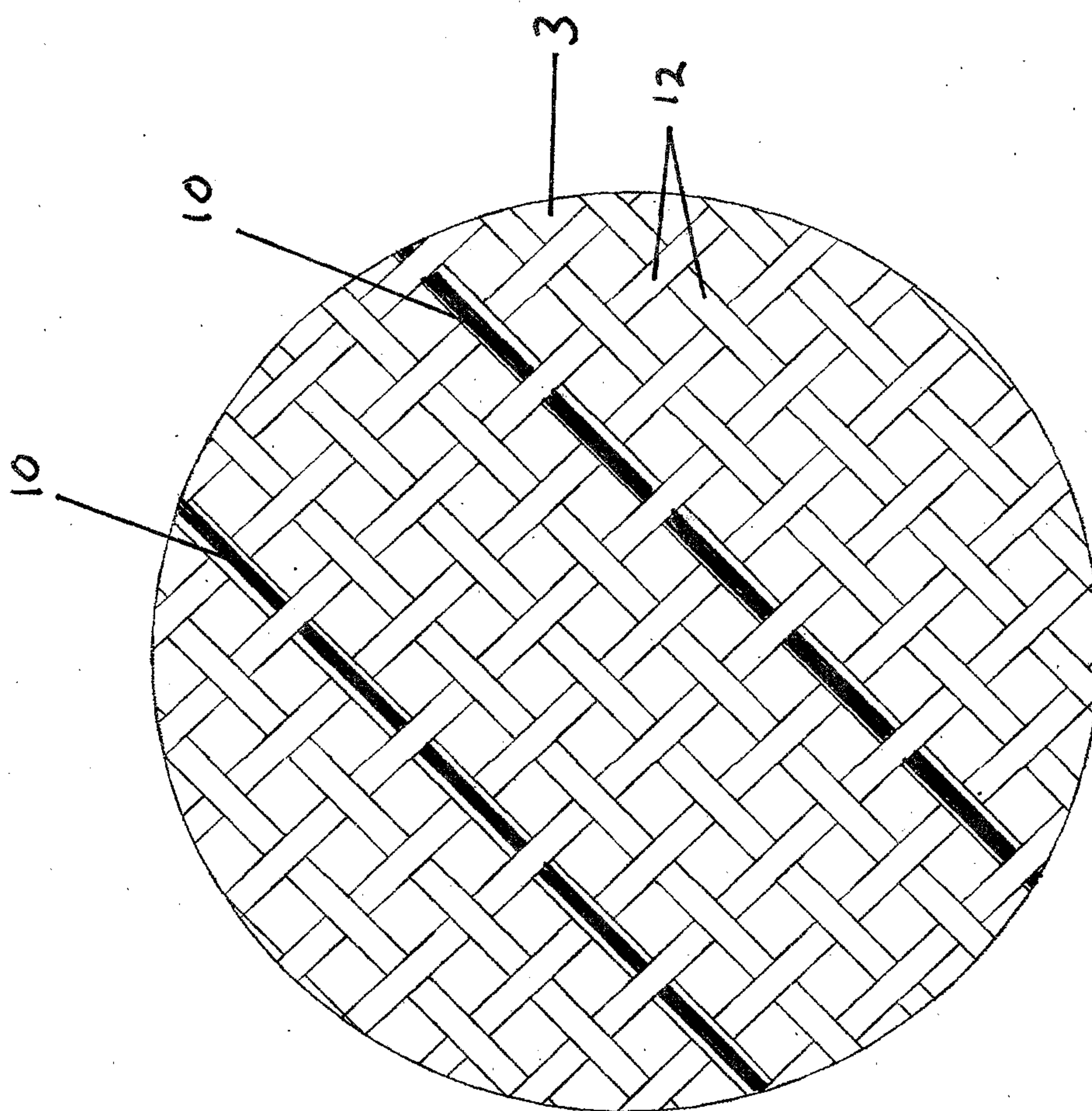

FIG. 7

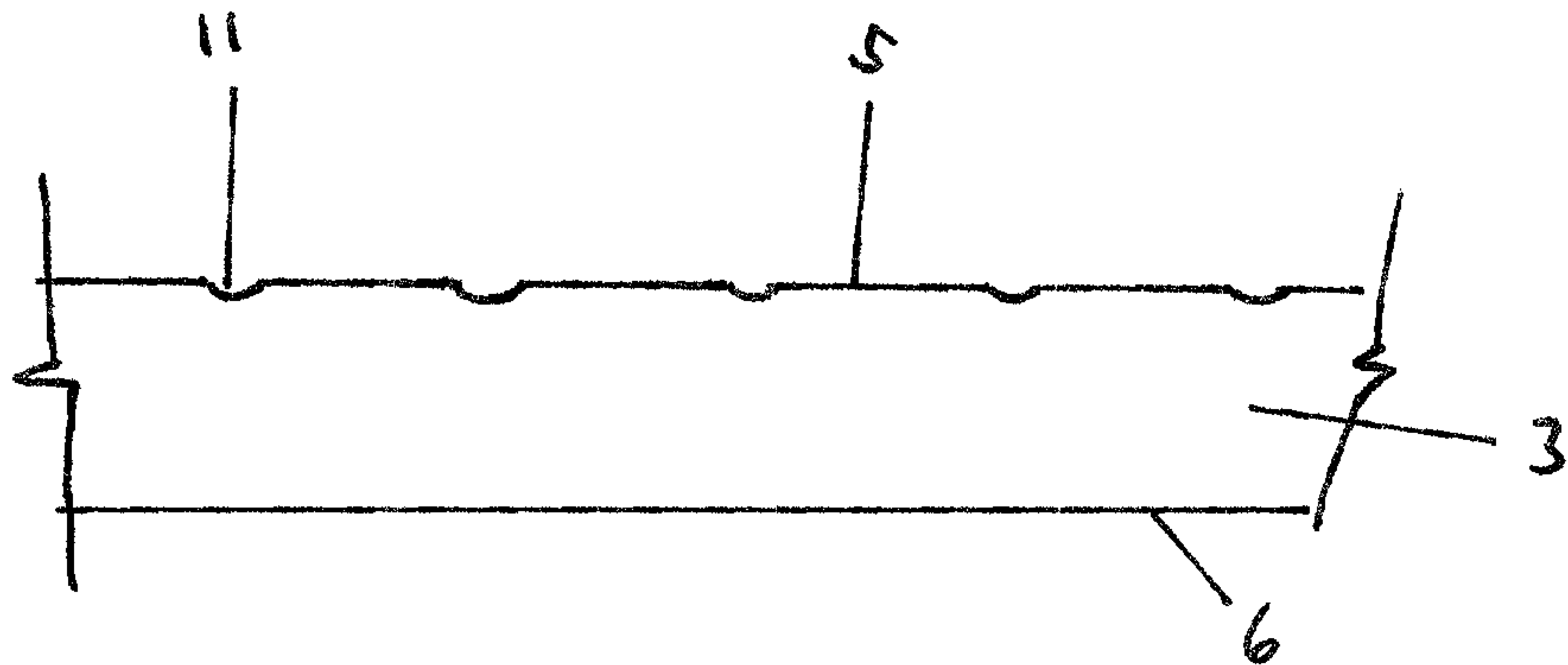

Fig 8

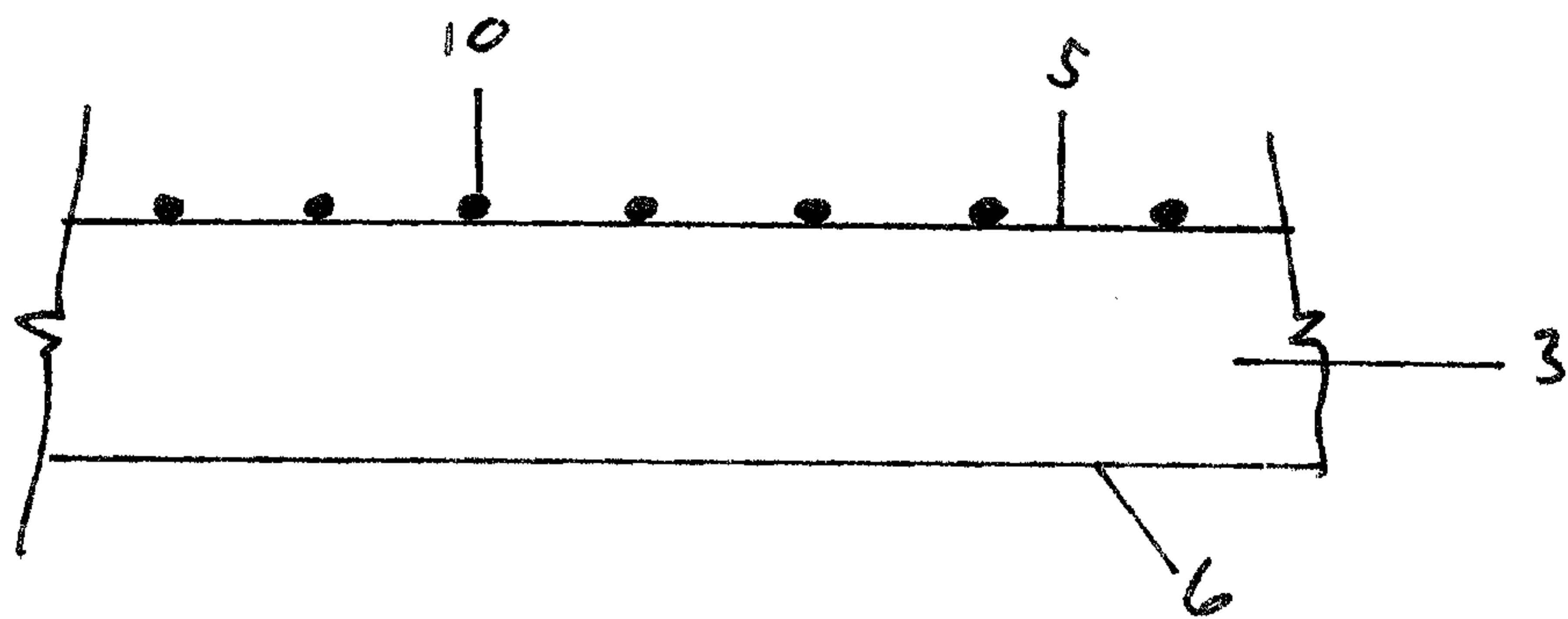

Fig 9

