

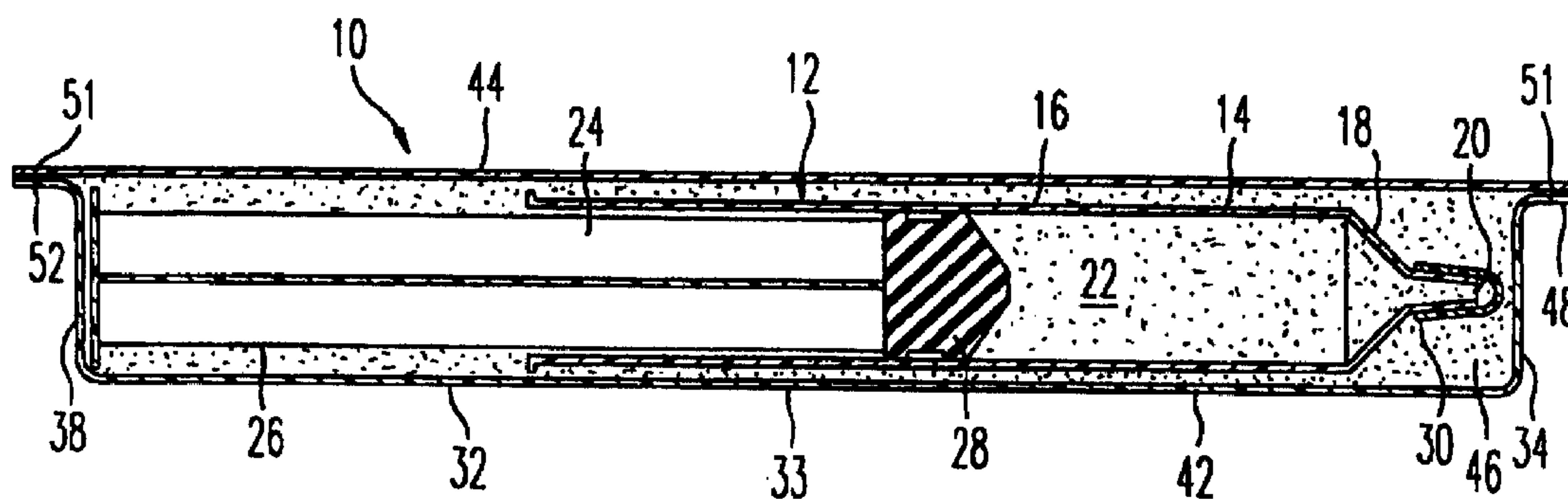

(72) LAMBORNE, ANDREW N., US
(72) DEJUAN, EUGENE M. D., JR., US
(71) THE JOHNS HOPKINS UNIVERSITY, US
(51) Int.Cl.⁶ B65D 85/20
(30) 1997/04/19 (08/838,824) US
(54) **SERINGUE A GAZ ET SON EMBALLAGE**
(54) **GAZ SYRINGE AND PACKAGE THEREFOR**



(57) L'invention concerne une seringue (12) à dose unitaire remplie de gaz, laquelle est remplie d'un gaz et conditionnée dans un matériau (10) formant barrière au gaz avant d'être utilisée, afin d'en augmenter la durée de vie, c'est-à-dire afin de réduire la fuite du gaz et la dilution du contenu de la seringue. La seringue (12) est remplie d'un gaz sélectionné et contenu de manière étanche à l'intérieur d'un récipient (10) composé d'un matériau présentant une étanchéité élevée au gaz. Le récipient a été également rempli du gaz sélectionné. Le matériau du récipient est choisi de manière à présenter une vitesse de transmission de gaz suffisante pour empêcher que le gaz choisi ne se diffuse à l'extérieur du récipient jusque dans l'atmosphère. La pression du volume de gaz se trouvant dans le récipient est supérieure à la pression atmosphérique de manière à empêcher les contaminants atmosphériques de pénétrer dans le récipient et dans la seringue.

(57) A unit dose, gas-filled syringe (12) is provided which is filled with a gas and packaged in a gas barrier material (10) prior to use to increase shelf-life, that is, to minimize gas leakage and dilution of the contents of the syringe. The syringe (12) is filled with a selected gas and sealed inside a container (10) made from a high gas barrier material. The container is also filled with the selected gas. The container material is selected to have a gas transmission rate sufficient to prevent the selected gas from diffusing out of the container into the atmosphere. The volume of the gas in the container is greater than the atmospheric pressure to prevent the atmospheric contaminants from entering the container and syringe.

PCT

WORLD INTELLECTUAL PROPERTY ORGANIZATION
International Bureau

INTERNATIONAL APPLICATION PUBLISHED UNDER THE PATENT COOPERATION TREATY (PCT)

(51) International Patent Classification ⁶ : B65D 85/20	A1	(11) International Publication Number: WO 98/45191 (43) International Publication Date: 15 October 1998 (15.10.98)
<p>(21) International Application Number: PCT/US98/07071</p> <p>(22) International Filing Date: 10 April 1998 (10.04.98)</p> <p>(30) Priority Data: 08/838,824 10 April 1997 (10.04.97) US</p> <p>(71) Applicant: JOHNS HOPKINS UNIVERSITY [US/US]; 720 Rutland Avenue, Baltimore, MD 21205 (US).</p> <p>(72) Inventors: LAMBORNE, Andrew, N.; 4212 Evans Chapel Road, Baltimore, MD 21211 (US). DEJUAN, Eugene, M., D., Jr.; 13721 Poplar Hill Road, Phoenix, MD 21131 (US).</p> <p>(74) Agents: LONGANECKER, Stacey, J. et al.; Roylance, Abrams, Berdo & Goodman, L.L.P., Suite 315, 1225 Connecticut Avenue, N.W., Washington, DC 20036 (US).</p>	<p>(81) Designated States: AL, AM, AT, AT (Utility model), AU, AZ, BA, BB, BG, BR, BY, CA, CH, CN, CU, CZ, CZ (Utility model), DE, DE (Utility model), DK, DK (Utility model), EE, EE (Utility model), ES, FI, FI (Utility model), GB, GE, GH, HU, IL, IS, JP, KE, KG, KP, KR, KZ, LC, LK, LR, LS, LT, LU, LV, MD, MG, MK, MN, MW, MX, NO, NZ, PL, PT, RO, RU, SD, SE, SG, SI, SK, SK (Utility model), SL, TJ, TM, TR, TT, UA, UG, UZ, VN, YU, ZW, ARIPO patent (GH, GM, KE, LS, MW, SD, SZ, UG, ZW), Eurasian patent (AM, AZ, BY, KG, KZ, MD, RU, TJ, TM), European patent (AT, BE, CH, CY, DE, DK, ES, FI, FR, GB, GR, IE, IT, LU, MC, NL, PT, SE), OAPI patent (BF, BJ, CF, CG, CI, CM, GA, GN, ML, MR, NE, SN, TD, TG).</p> <p>Published <i>With international search report.</i> <i>With amended claims.</i></p>	

(54) Title: GAZ SYRINGE AND PACKAGE THEREFOR

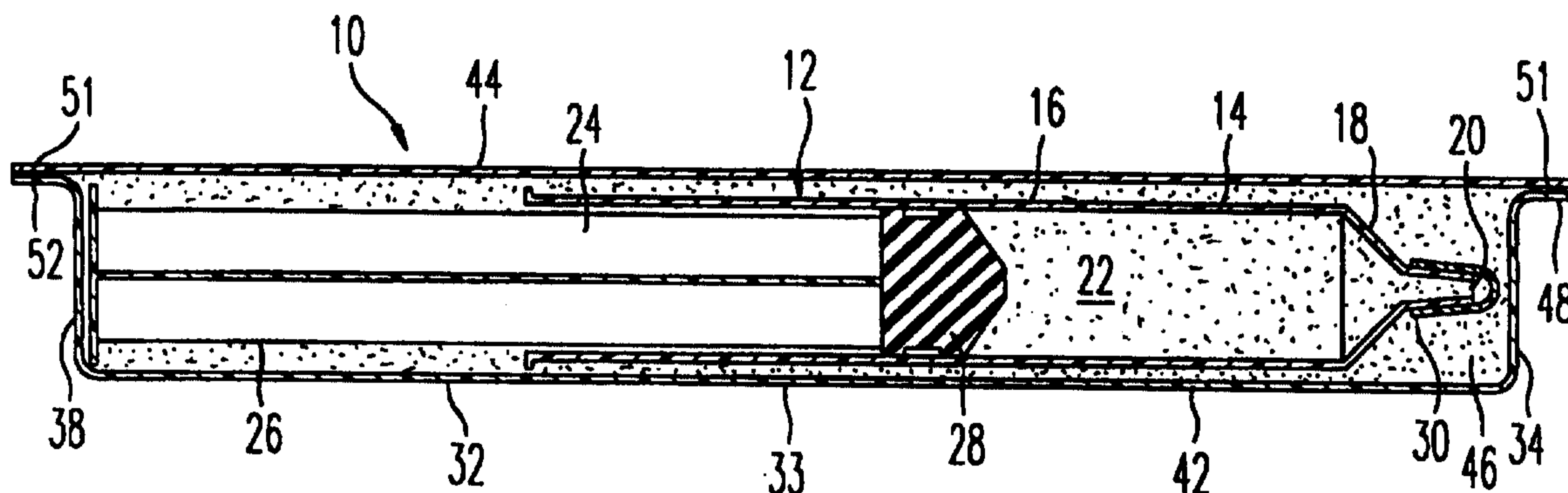

(57) Abstract

A unit dose, gas-filled syringe (12) is provided which is filled with a gas and packaged in a gas barrier material (10) prior to use to increase shelf-life, that is, to minimize gas leakage and dilution of the contents of the syringe. The syringe (12) is filled with a selected gas and sealed inside a container (10) made from a high gas barrier material. The container is also filled with the selected gas. The container material is selected to have a gas transmission rate sufficient to prevent the selected gas from diffusing out of the container into the atmosphere. The volume of the gas in the container is greater than the atmospheric pressure to prevent the atmospheric contaminants from entering the container and syringe.

GAS SYRINGE AND PACKAGE THEREFOR

Field of the Invention:

The invention relates generally to a pre-filled package containing a unit dose of medical gas and a method of making same.

- 2 -

Background of the Invention:

Gas-filled syringes are useful for a number of applications such as surgical procedures involving the injection of a gas bubble into a patient's body. For example, a retinal tear can be treated using an intraocular surgical procedure during which a gas such as sulfur hexafluoride (SF_6) or perfluoropropane (C_3F_8) is injected into the eye for gas tamponage. Carbon dioxide (CO_2) gas can be injected into a blood vessel to facilitate percutaneous angioscopy. Nitric oxide (NO) gas and NO-releasing compounds can also be used to treat a number of medical conditions. For example, NO and NO-releasing compounds can be used for treatment of male impotence, inhibition of DNA synthesis and mitochondrial respiration in tumor cells, and relaxation of vascular smooth muscle for control of hypertension.

Gases used for surgery are often expensive and not available for purchase in ready-to-use form. Currently, gases for surgical procedures are purchased in a pressurized tank. Syringes are filled directly from the tank using a filling line. When a syringe is disconnected from the filling line, the gas in the filling line is released into the atmosphere. Thus, this method of preparing syringes for surgery is disadvantageous because a significant amount of gas is wasted. Due to the busy environment of a hospital, shut-off valves on gas tanks are frequently left open accidentally, causing an even greater amount of gas to be wasted than when gas syringes are being filled.

In addition to the problem of wasting expensive gases, a more serious clinical problem associated with filling

- 3 -

syringes from gas tanks is dilution of the gas in the syringe prior to surgery. Syringes are sometimes prepared on the morning of the day they are to be used in surgery. The syringes are then placed in the operating room with
5 other surgical devices until they are needed, which can be several hours later. Experiments have shown that leakage of gas from a syringe over a relatively short period of time can cause clinically significant dilution of the gas dose and therefore increase the risk of surgical complications.
10 For instance, the concentration of sulfur hexafluoride in a plastic syringe has been observed to decrease from 97% at 30 seconds after aspiration to 76% at 60 minutes and 2% at 18 hours past aspiration.

15 Summary of the Invention:

The present invention overcomes the above-described disadvantages associated with known methods for preparing gas-filled syringes, while also realizing a number of advantages. In accordance with one aspect of the invention,
20 a unit dose, gas-filled syringe is provided which is filled with gas and packaged in a gas barrier material prior to use to increase shelf-life, that is, minimize gas leakage and dilution of the contents of the syringe. The syringe is initially filled with a selected gas and sealed inside a
25 container made from a high gas barrier material. The container is then also filled with the selected gas. The container material is selected to have a gas transmission rate sufficient to prevent the selected gas from diffusing out of the container into the atmosphere and to prevent
30 atmospheric gas contaminants from entering the container.

- 4 -

In accordance with another aspect of the present invention, a method of packaging a gas-filled syringe is provided which comprises the steps of forming a container from a gas barrier material to enclose the syringe, placing
5 the gas-filled syringe in the container, filling the container with the same gas as in the pre-filled gas syringe, and sealing the container to retain the gas and the syringe therein.

In accordance with yet another aspect of the present
10 invention, a method of packaging a gas-filled syringe is provided which comprises the steps of forming a container from a gas barrier material to enclose the syringe, the container comprising a valve, placing the gas-filled syringe
15 in the container, sealing the container to retain the syringe therein, evacuating the sealed container, and filling the container with the same gas as in the syringe using the valve.

In accordance with still yet another aspect of the present invention, a method of preparing a gas-filled
20 syringe is provided which comprises the step of filling a container with a predetermined volume of a selected gas via an opening therein. The container is formed from a high gas barrier material to prevent gas from escaping from the container once the opening is sealed. The method further
25 comprises the step of puncturing the container with the syringe needle and drawing the gas into the syringe by retracting the syringe plunger.

Brief Description of the Drawings:

These and other features and advantages of the present invention will be more readily apprehended from the following detailed description when read in connection with the appended drawings, in which:

Fig. 1 is an isometric view of a container and cover constructed in accordance with an embodiment of the present invention for containing a gas and enclosing a syringe filled with gas;

Fig. 2 is a side cross-sectional view of the container and cover depicted in Fig. 1 showing the syringe contained therein;

Fig. 3 is a top view of the container depicted in Fig. 1 without the cover or syringe;

Fig. 4 is an isometric view of a container constructed in accordance with an embodiment of the present invention for containing a gas and enclosing a syringe filled with gas;

Fig. 5 is a side cross-sectional view of the container depicted in Fig. 4 showing the syringe contained therein; and

Fig. 6 is a side cross-sectional view of a container constructed in accordance with another embodiment of the present invention for containing a gas.

Detailed Description of the Preferred Embodiments:

With reference to Fig. 1, a container 10 for enclosing a gas syringe 12 is shown in accordance with an embodiment of the present invention. Before describing the container 10, an exemplary syringe 12, as shown in Fig. 2, will be

- 6 -

described. It is to be understood that other types of gas-filled syringes can be used in accordance with the present invention. The exemplary gas syringe 12 comprises a tubular housing 14 having longitudinally cylindrical section 16, a frustoconical section 18 and a gas dispensing tip 20 which are all preferably formed as an integral, unitary member. The tubular housing can be formed from a material with a high degree of gas impermeability such as glass. The tubular housing, however, can be a gas permeable material such as plastic since the container 10 of the present invention is designed to prevent dilution and contamination of the syringe contents, as will be described in further detail below.

With continued reference to Fig. 2, the interior circumference of the tubular housing 14 defines a cavity 22 which can be filled with a selected gas in a conventional manner. The gas is retained within the cavity 22 by a plunger 24. The end of the plunger 24 that is proximal with respect to the frustoconical section 18 of the housing 14 can be provided with a stopper 28 which is dimensioned to slidably engage the inner circumference of the cylindrical section 16 of the tubular housing 14 to controllably change the level of gas pressurization within the cavity 22. The tip 20 can be fitted with a removable cap 30. The syringe, however, can be open at the tip 20, or have a cannula or needle on the tip 20, or have an integral needle or tube molded on the front of the syringe. In any case, the container 10 is designed to prevent the gas in the syringe 12 from being diluted or contaminated regardless of whether the cavity 22 is completely sealed.

- 7 -

With reference to Figs. 1, 2 and 3, the container 10 comprises a bottom portion 32 and a top portion 44. In accordance with an embodiment of the present invention, the bottom portion 32 is preferably molded or otherwise formed to create a trough or open container dimensioned to at least accommodate the syringe 10 having its plunger 24 at least partially withdrawn from the cavity 22 of the housing 14. For example, the bottom portion 32 can comprise a bottom wall 38 and four side walls 34, 36, 38 and 40 which preferably form a unitary, integral member defining a cavity 46 in which the syringe is placed. The tops of the side walls 34, 36, 38 and 40 are each provided with a flange 48, 50, 52 and 54. The top portion 44 is dimensioned to cover the opening 56 of the bottom portion 32 of the container 10, as well as engage each flange 48, 50, 52 and 54. The top portion 44 and the bottom portion therefore can be sealed together using, for example, an adhesive 51 on the flanges 48, 50, 52 and 54. Alternatively, the material from which the top portion 44 and the bottom portion 32 are formed can be fused together via heat sealing, as indicated at 53 in Fig. 5. In either case, the sealed joint formed at the flanges 48, 50, 52 and 54 satisfies the gas barrier criteria sufficient to maintain the purity of the contents (i.e., gas) in the container 10 and syringe 12, if a syringe is placed in the container 10.

Although the bottom portion 32 of the container is shown as rectangular in shape and having a rectangular recess or trough, a variety of shapes can be used. For example, the bottom portion 32 of the container can be formed into a more complicated shape than a rectangle to

- 8 -

approximately conform to the shape of its contents (e.g., a syringe 12). In addition, the top portion 44 need not be planar. For example, as shown in Figs. 4 and 5, the top portion 44 and the bottom portion 32 of the container 10 can both be nonplanar and configured to form the cavity 46 when adhered together. Further, the top portion 44 and the bottom portion 32 of the container 10 can be configured to have a curvilinear cross-section (Fig. 4) with tapered ends 58 and 60, and 62 and 64, respectively (Fig. 5). The ends are adhered together along the flanges 48, 50, 52 and 54 of the bottom portion and corresponding flanges 66, 68, 70 and 72 of the top portion 44 of the container 10. Alternatively, the top portion 44 and bottom portion 32 of the container 10 can be formed as a unitary and integral piece of high gas barrier material designated as 74 in Fig. 6 which is folded on one side 76 thereof. The two, free ends 78 and 82 are then sealed with an adhesive layer 83 or by heat sealing depending on the material used to form the container 10.

In accordance with an embodiment of the invention, the container 10 is preferably made of a high gas barrier material such as a metallized polymer laminate which can be sealed to retain a selected gas inside the container. The syringe 12 is filled in a conventional manner with a unit dose of the selected gas (e.g., sulfur hexafluoride or nitric oxide). The syringe 12 is then placed within the bottom portion 32 of the container 10 with the plunger 24 at least partially withdrawn from the cavity 22. The container 10 is then filled with preferably the same gas as the syringe 12 and sealed using the top portion 44 (e.g., by

- 9 -

applying an adhesive or heat sealing along the flanges 48, 50, 52 and 54 of the bottom portion 32 to adhere to the edges of the top portion 44). Alternatively, the container 10 can be made from a sheet 74 of high gas barrier material that is folded. A gas-filled syringe can be placed between the two free ends 78 and 82 of the sheet 74. The space between the free ends is then filled with the same gas and sealed to enclose the gas and gas-filled syringe. Thus, the sealed container 10 provides a sufficient gas barrier to prevent the gaseous content of the container, and therefore the syringe, from leaking outside the container, and to prevent gaseous contaminants from diffusing into the container and the syringe. Further, the use of the same gas inside the container as well as inside the syringe facilitates the maintenance of the selected gas within the syringe since any gas exchange occurring through the walls of the syringe does not dilute the unit gas dose therein.

As stated previously, the high gas barrier material for the container 10 prevents diffusion of gas molecules from the atmosphere through the container walls and therefore dilution or contamination of the unit gas dose within the syringe 12. The shelf life of the unit gas dose is determined by the rate at which gaseous contaminants such as oxygen molecules from the surrounding atmosphere diffuse into the container 10, or the rate at which the selected gas inside the container 10 diffuses out. The following formula can be used to calculate the maximum allowable gas transmission rate GTR_{MAX} for the container material:

- 10 -

$$GTR_{MAX} = V \times \frac{(1 - P)}{A \times S}$$

where V is the volume of the container 10, P is the minimum
5 acceptable purity of the unit gas dose in the syringe 12, A
is the surface area of the container 10, and S is the
desired shelf life of the unit gas dose in the syringe 12.

By way of an example, a unit dose of sulfur
hexafluoride of at least ninety-five percent (i.e., P = 95%)
10 purity is desired. The syringe 12 is packaged in a
container 10 having a volume V of 20 cubic inches and a
surface area A of 64 square inches. A one year shelf life
is desired. The maximum allowable gas transmission rate
GTR_{MAX} for the container 10 material is therefore 0.0156
15 cubic inches per square inches per year (or 0.07 cc per 100
square inches per 24 hours). A purity level of 95% in the
example above was chosen for illustrative purposes only.
The minimum acceptable purity level of gas can vary,
depending on the type of gas used and the application for
20 its use. Embodiments providing higher or lower priority
levels are covered under the scope of the present invention.

Suitable materials for the container 10 can include,
but are not limited to, metal foils such as aluminized foil
laminates. Other examples of container 10 material include
25 laminates having one or more metallized layers of nylon,
oriented polypropylene (OPP), polyethylene (PE), ethylene
vinyl alcohol (EVOH), polyethylene terephthalate (PET), low
density polyethylene (LDPE), medium density polyethylene
(MDPE), and/or cellophane. A lacquer coating can also be
30 used to create a cold seal.

- 11 -

Some of the gases used in surgery have large molecules which cannot pass through polymeric or metallic films as readily as oxygen. Oxygen and other gaseous contaminants cannot dilute the unit gas dose in the syringe 12 unless one of two conditions exists. First, if the container 10 material allows some of the selected gas in the container to diffuse out into the atmosphere, then the volume of gas lost in the container 10 is replaced with other gas constituents from the atmosphere. Second, if the pressure in the container 10 is less than atmospheric pressure outside the container, then the gaseous contaminants may diffuse into the container regardless of whether any interior container gas diffuses out. If the pressure in the container 10 is essentially maintained above the atmospheric pressure, then the container material can be chosen on the basis of the transmission rate of the gas in the container. In cases where the selected gas is characterized by large molecules, materials providing considerably lower gas barriers can be used as compared with materials providing barriers to gases with relatively small molecules. If the pressure in the container is not maintained above atmospheric pressure, then the highest relevant gas transmission rate, which is typically the gas transmission rate of oxygen in the surrounding atmosphere, is preferably used as the basis for selecting a container material.

A controlled atmosphere of a selected gas inside the container 10 can be achieved in a number of ways. For example, a form/fill/seal machine can be used. The form/fill/seal machine provides an evacuated assembly area therein which is filled with the selected gas. The web(s)

- 12 -

of a high gas barrier material selected to construct one or more containers 10 is feed into the area. One part of the container can be formed, for example, with a recess or trough of sufficient size to accommodate a pre-filled gas syringe therein. The container construction is then completed by enclosing the syringe within the container using, for example, another piece of the web to cover the recess. The other piece of the web can be sealed against the first part of the web using an adhesive or heat sealing. The controlled gaseous assembly area, therefore, ensures that the container is filled with the same gas as the syringe to avoid the aforementioned-mentioned problem of dilution caused by gas contaminants mixing with the contents of the syringe inside the container 10.

Alternatively, a controlled atmosphere of a selected gas inside the container 10 can be achieved by providing the container with a valve which permits evacuation of a sealed container having a pre-filled gas syringe enclosed therein and subsequent filling of the container with the selected gas. Further, the container 10 need not be provided with a syringe 12 at all. In accordance with an embodiment of the present invention, the container 10 can be filled with a selected gas (e.g., using a form/fill/seal machine that does not insert a syringe prior to sealing, or by evacuation, ejection with a selected gas and sealing). The container 10 containing the selected gas can then be drawn into an empty syringe by puncturing the container 10 with a needle and drawing the gas into the syringe cavity 22 with the plunger 24. Alternatively, a syringe can be constructed with a sufficiently gas impermeable tubular housing 14, stopper 28

and cap 30 combination to obviate the need for a container 10. The syringe can therefore be pre-filled with a selected gas prior to use and prevent contamination of the gas therein until the cap 30 is removed.

5 The container 10, whether it is provided with a syringe 12 therein or not, is preferably sterilized so it can be used in surgery, for example. A number of methods for sterilization can be used. The container 10 can be sterilized, for example, as it is being formed inside a
10 form/fill/seal machine. The syringe can be sterilized before it is inserted into a sterile chamber in the form/fill/seal machine, or the syringe 12 and new formed container 10 can both be sterilized as they are assembled together. A container 10 containing only gas and no syringe
15 can be sterilized inside a form/fill/seal machine or be sterilized after it is assembled and before it is filled with gas if an atmosphere-controlled assembly and fill area is not available.

In accordance with the present invention, a pre-filled
20 package containing a unit dose of medical gas and method of making same is provided. The pre-filled package can be a package, a package containing a syringe or a syringe having a gas impermeable chamber. The pre-filled package prevents contamination of the gas therein for use in a number of
25 applications, such as injection of a gas bubble into a patient's eye for treating a retinal tear, or injection of carbon dioxide into a blood vessel to displace blood and allow an improved field of view during percutaneous angiography. The material with which the package is made is
30 selected to maintain a desired purity level of gas within

- 14 -

the package. Further, the aforementioned problems associated with dispensing expensive gases from a tank in preparation for a medical procedure are avoided.

5 While certain advantageous embodiments have been chosen to illuminate the invention, it will be understood by those skilled in the art that various changes and modifications can be made herein without departing from the scope of the invention as defined in the appended claims.

AMENDED CLAIMS

[received by the International Bureau on 7 August 1998 (07.08.98);
original claim 1 amended; new claim 25 added; remaining claims
unchanged (2 pages)]

1. A gas syringe apparatus comprising:
 - a pre-filled gas syringe comprising a unit dose of a selected gas; and
 - a container constructed from a gas barrier material and configured to enclose said gas syringe to protect said gas syringe from contaminants in the atmosphere external to said container, said container comprising a predetermined volume of said selected gas therein, said container having pressure at least substantially equal to atmospheric pressure to reduce diffusion of said contaminants into said container, said gas barrier material being characterized by a maximum allowable gas transmission rate sufficient to substantially reduce diffusion of said selected gas from within said container.

2. A gas syringe apparatus comprising:
 - a pre-filled syringe comprising a unit dose of a selected gas; and
 - a container constructed from a gas barrier material and configured to enclose said syringe to protect said syringe from contaminants in the atmosphere external to said container, said container comprising a predetermined volume of said selected gas therein, said container having less than atmospheric pressure, said gas barrier material being characterized by a maximum allowable gas transmission rate sufficient to substantially reduce diffusion of said contaminants into said container.

- 16 -

3. A method of preparing a gas-filled syringe prior to its use, comprising the steps of:

filling a syringe with a selected gas;

forming a container from a gas barrier material to
5 enclose said syringe;

placing said syringe in said container;

filling said container with said selected gas; and

sealing said container to retain said selected gas and
said syringe therein and protect said syringe from
10 contaminants in the atmosphere external to said container.

4. A method as claimed in claim 3, said container has pressure at least substantially equal to atmospheric pressure and said gas barrier material is characterized by a
15 maximum allowable gas transmission rate sufficient to substantially reduce diffusion of said selected gas from within said container.

5. A method as claimed in claim 3, wherein said container
20 has less than atmospheric pressure and said gas barrier material is characterized by a maximum allowable gas transmission rate sufficient to substantially reduce diffusion of said contaminants into said container.

25 6. A method as claimed in claim 3, further comprising the step of sterilizing at least one of said syringe, said gas barrier material and the combination of said syringe inside said container.

- 17 -

7. A method of preparing a gas-filled syringe prior to its use, comprising the steps of:

filling a syringe with a selected gas;

forming a container from a gas barrier material to
5 enclose said syringe, said container comprising a valve;

placing said syringe in said container;

sealing said container to retain said syringe therein
and protect said syringe from contaminants in the atmosphere
external to said container;

10 evacuating said sealed container via said valve; and

filling said container with said selected gas using
said valve.

8. A method as claimed in claim 7, wherein said gas
15 barrier material is characterized by a maximum allowable gas
transmission rate sufficient to substantially reduce
diffusion of said selected gas from within said container.

9. A method as claimed in claim 7, wherein said filling
20 step comprises the step of providing a predetermined volume
of said selected gas in said container, said container
having less than atmospheric pressure, said gas barrier
material being characterized by a maximum allowable
transmission rate sufficient to substantially reduce
25 diffusion of said contaminants into said container.

10. A method as claimed in claim 7, further comprising the
step of sterilizing at least one of said syringe, said gas
barrier material and the combination of said syringe inside
30 said container.

- 18 -

11. A method of preparing a pre-filled gas syringe prior to its use, comprising the steps of:

forming a container from a gas barrier material to
5 enclose said syringe;

placing said syringe in said container;

filling said container with the same gas as in said
pre-filled gas syringe; and

sealing said container to retain said gas and said
10 syringe therein and protect said syringe from contaminants
in the atmosphere external to said container.

12. A method as claimed in claim 11, wherein said gas
barrier material is characterized by a maximum allowable gas
15 transmission rate sufficient to substantially reduce
diffusion of said selected gas from within said container.

13. A method as claimed in claim 11, wherein said container
has less than atmospheric pressure, said gas barrier
20 material being characterized by a maximum allowable
transmission rate sufficient to substantially reduce
diffusion of said contaminants into said container.

14. A method as claimed in claim 11, further comprising the
25 step of sterilizing at least one of said syringe, said gas
barrier material and the combination of said syringe inside
said container.

15. A method of preparing a pre-filled gas syringe prior to
30 its use, comprising the steps of:

- 19 -

forming a container from a gas barrier material to enclose said syringe, said container comprising a valve;

placing said syringe in said container;

sealing said container to retain said syringe therein
5 and protect said syringe from contaminants in the atmosphere external to said container;

evacuating said sealed container; and

filling said container with the same gas as in said syringe using said valve.

10

16. A method as claimed in claim 15, wherein said gas barrier material is characterized by a maximum allowable gas transmission rate sufficient to substantially reduce diffusion of said selected gas from within said container.

15

17. A method as claimed in claim 15, wherein said container has less than atmospheric pressure, said gas barrier material being characterized by a maximum allowable transmission rate sufficient to substantially reduce
20 diffusion of said contaminants into said container.

18. A method as claimed in claim 15, further comprising the step of sterilizing at least one of said syringe, said gas barrier material and the combination of said syringe inside
25 said container.

19. A method of preparing a gas-filled syringe having a needle, a chamber for containing a gas, and a plunger, comprising the steps of:

- 20 -

filling a sealable container with a selected gas, said container comprising a metallized polymer laminate having a maximum allowable gas transition rate sufficient to limit diffusion of said gas from said container to a desired
5 level;

sealing said container;

puncturing said container using said needle; and

retracting said plunger from within said chamber to draw said selected gas into said chamber.

10

20. A method as claimed in claim 19, further comprising the step of sterilizing said container.

21. A method as claimed in claim 19, further comprising the
15 steps of:

removing said needle from said container;

inserting said needle into a patient's body; and

at least partially inserting said plunger into said chamber to dispense said selected gas from said chamber into
20 said patient's body via said needle.

22. A method of using a pre-filled package containing a unit dose of medical gas comprising the steps of:

puncturing said package using a needle on a syringe
25 having a chamber and a plunger;

withdrawing said plunger from within said chamber to draw said gas from said package into said chamber;

removing said needle from said package;

inserting said needle into a patient's body; and

- 21 -

at least partially inserting said plunger into said chamber to dispense said gas from said chamber into said patient's body.

5 23. A method of dispensing a unit dose of medical gas from a syringe having a needle, a plunger and a chamber for enclosing the unit dose of medical gas comprising the steps of:

10 opening a package, said package being sealed to contain said syringe therein and comprising a metallized polymer laminate having a gas transition rate sufficient to limit at least one of the diffusion of said gas in said syringe from said package and the diffusion of contaminants from the atmosphere into said package until said package is opened;

15 removing said syringe from said package;

inserting said needle into a patient's body; and

at least partially inserting said plunger into said chamber to dispense said gas from said chamber into said patient's body.

20

24. A gas syringe comprising:

a tubular housing having an open end and a gas dispensing end;

25 a removable cap configured to be detachably mounted on said gas dispensing end of said tubular housing;

a plunger having a first end configured to be inserted into said open end of said tubular housing and having a circumference dimensioned to slidably engage said inner perimeter of said tubular housing, said removable cap and
30 said plunger being configured to substantially prevent

diffusion of a gas from within said tubular housing, said plunger being inserted into and retracted from said tubular housing through said open end thereof to change the pressure of said gas within said tubular housing; said tubular housing, said removable cap and said plunger each being constructed from at least one gas barrier material to substantially prevent diffusion of said gas from within said gas syringe, and diffusion of contaminants from the atmosphere external to said gas syringe into said gas syringe, until said removable cap is removed.

25. A gas syringe apparatus as claimed in claim 1, wherein said gas barrier material is selected to have a maximum allowable gas transmission rate determined using $V \times (1 - p) / (A \times S)$ wherein V is the volume of said container, p is the minimum accepted impurity of said unit dose of said selected gas, A is the surface area of said container, and S is the desired shelf life of said unit dose of said selected gas in said gas syringe.

1/3

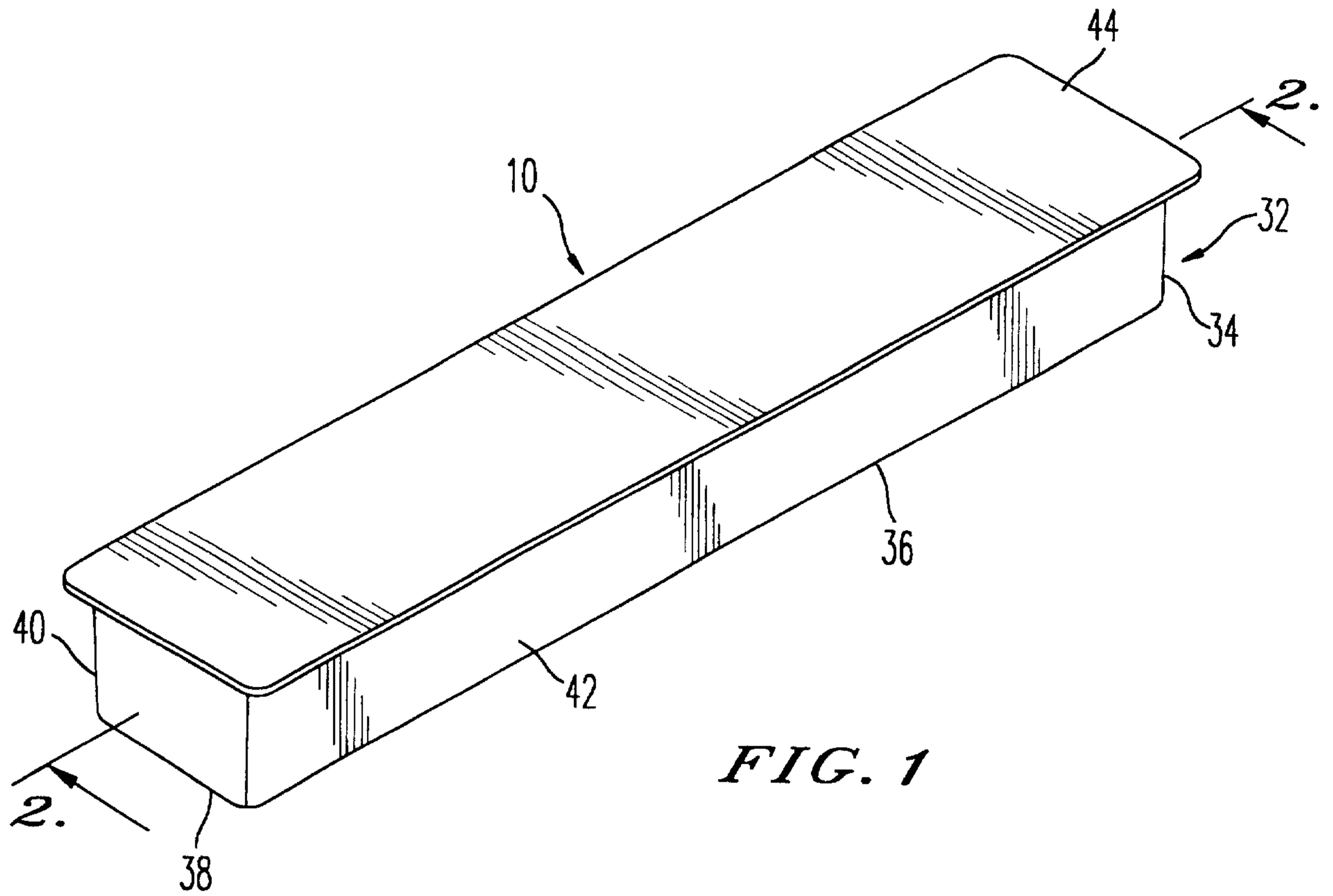

FIG. 1

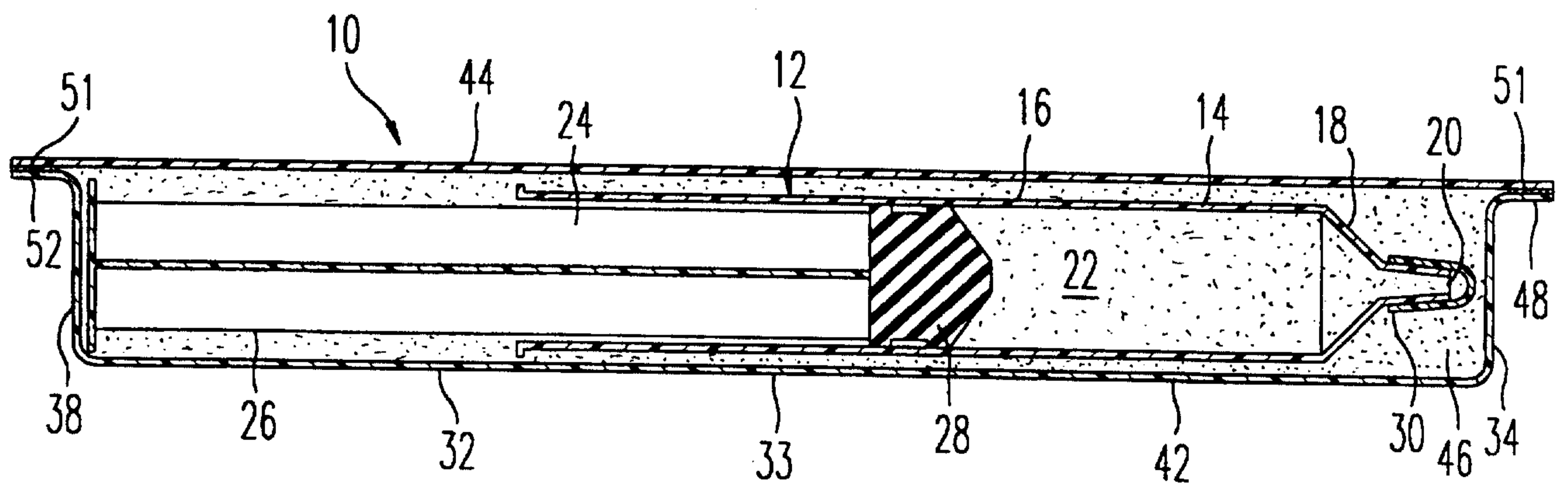

FIG. 2

2/3

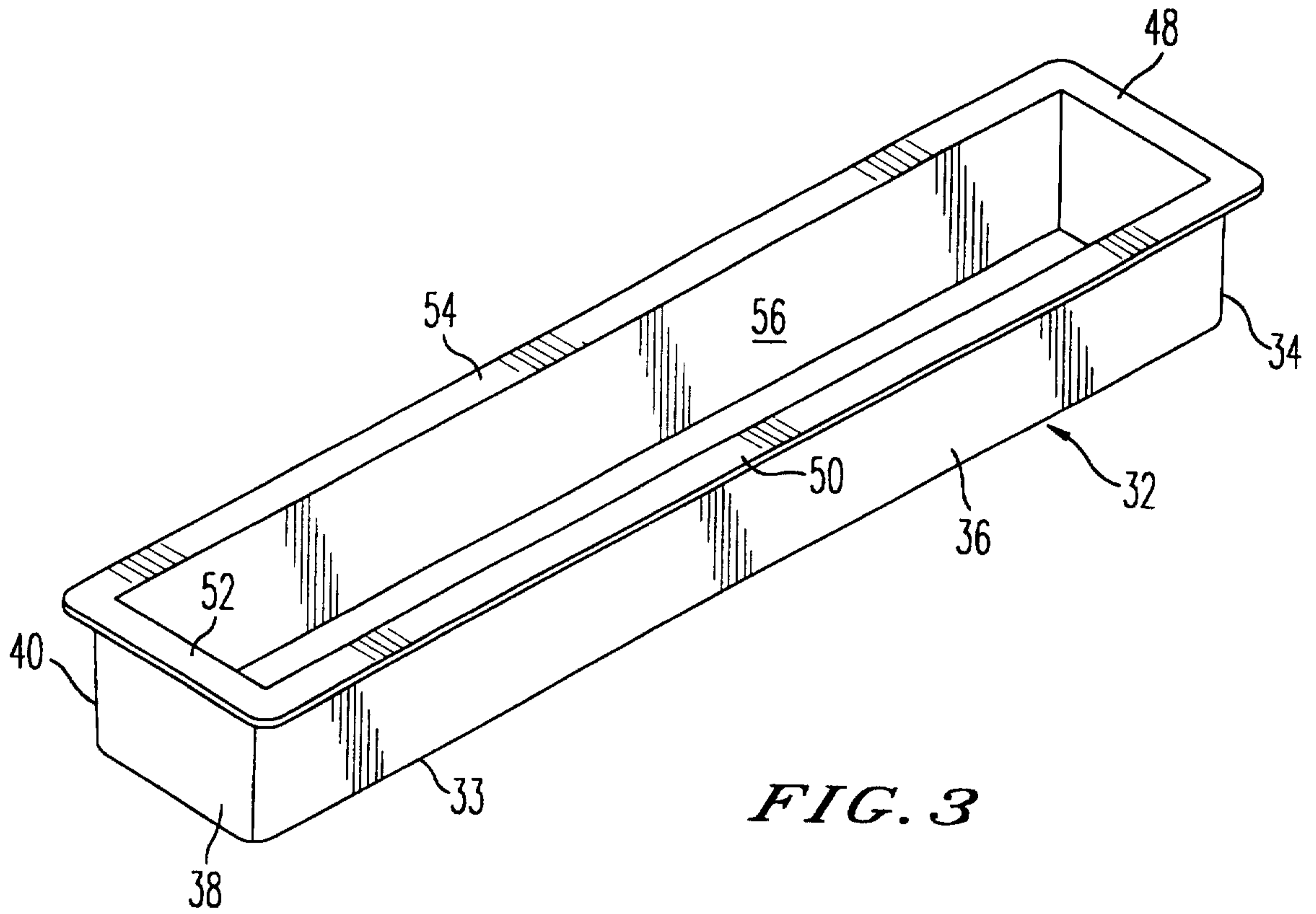

FIG. 3

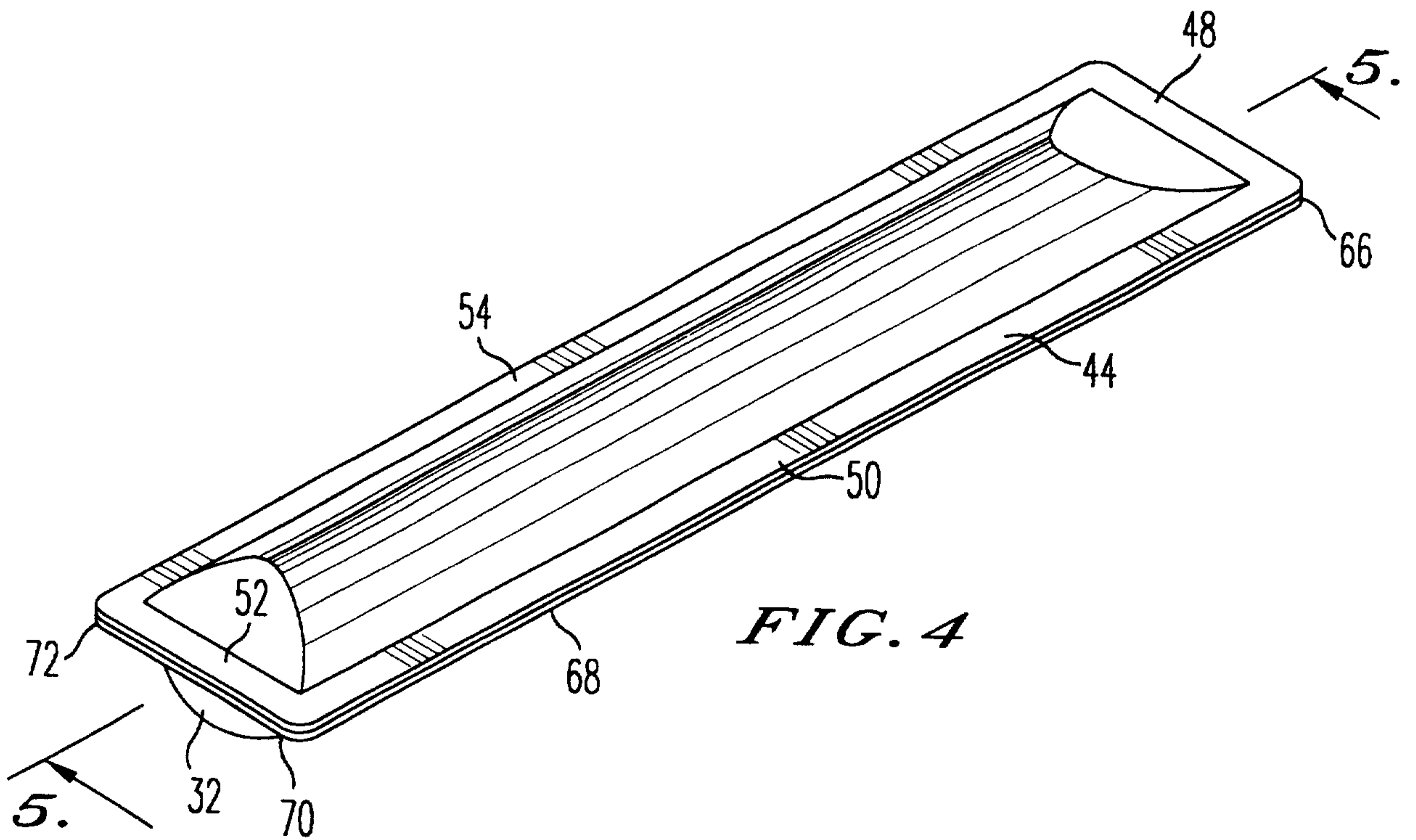

FIG. 4

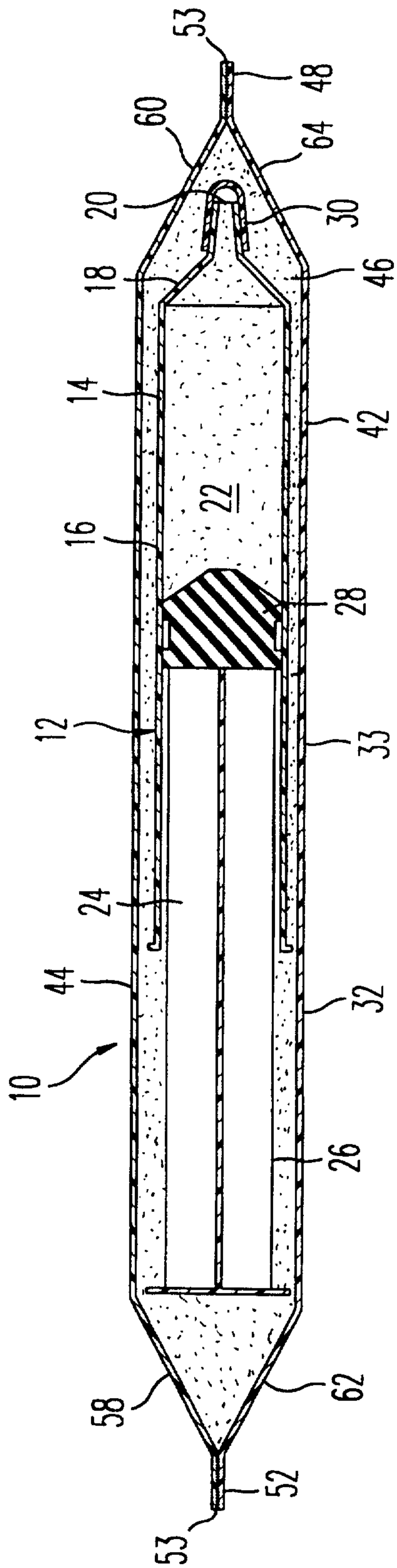

FIG. 5

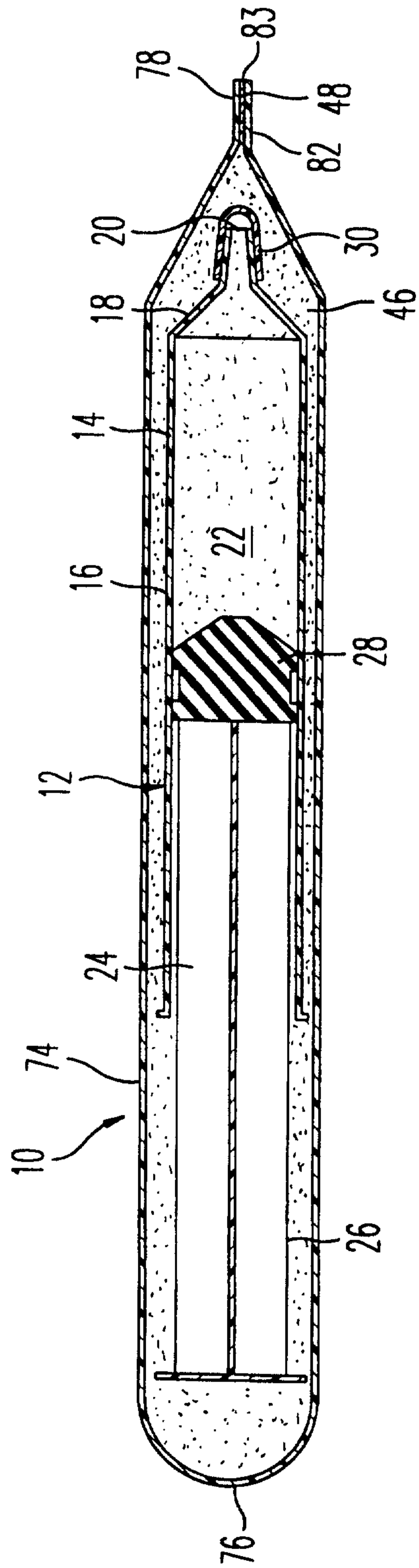

FIG. 6