



(86) Date de dépôt PCT/PCT Filing Date: 2007/07/25
 (87) Date publication PCT/PCT Publication Date: 2008/07/31
 (45) Date de délivrance/Issue Date: 2018/05/15
 (85) Entrée phase nationale/National Entry: 2009/01/23
 (86) N° demande PCT/PCT Application No.: US 2007/074320
 (87) N° publication PCT/PCT Publication No.: 2008/091377
 (30) Priorité/Priority: 2006/07/25 (US11/492,423)

(51) Cl.Int./Int.Cl. *C22C 19/05* (2006.01),
B22D 25/00 (2006.01), *C22F 1/10* (2006.01)
 (72) Inventeurs/Inventors:
BIONDO, CHARLES, US;
STROHL, J. PAGE, US;
SAMUELSON, JEFFERY W., US;
FUCHS, GERHARD E., US;
WLODEK, RAMONA T., US
 (73) Propriétaire/Owner:
ANSALDO ENERGIA IP UK LIMITED, GB
 (74) Agent: SMART & BIGGAR

(54) Titre : ALLIAGE A BASE DE NICKEL POUR APPLICATIONS DE TURBINES A GAZ
 (54) Title: NICKEL-BASE ALLOY FOR GAS TURBINE APPLICATIONS

**Typical Blade
Creep Rupture Life (Equiaxed)**

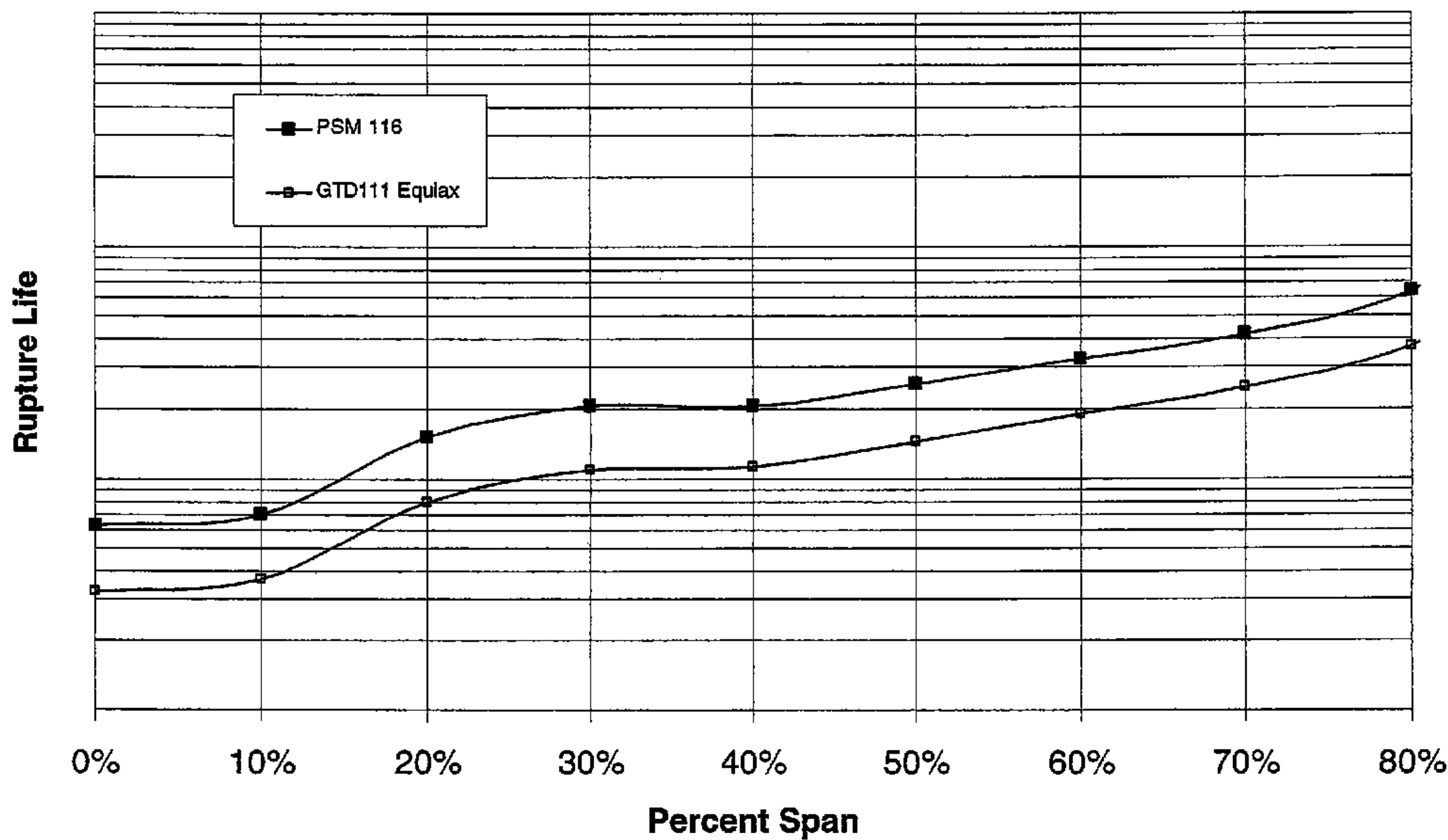

(57) **Abrégé/Abstract:**

A nickel-based alloy suitable for casting gas turbine components having a lower density and basic heat treating process while achieving improved strength is disclosed. Multiple embodiments of the alloy are disclosed capable of providing both directionally-solidified and equiaxed castings. Also disclosed is a method of making a cast and heat treated article utilizing the improved nickel-base alloy.

(12) INTERNATIONAL APPLICATION PUBLISHED UNDER THE PATENT COOPERATION TREATY (PCT)

(19) World Intellectual Property Organization
International Bureau(43) International Publication Date
31 July 2008 (31.07.2008)

PCT

(10) International Publication Number
WO 2008/091377 A3(51) International Patent Classification:
C22C 19/03 (2006.01)(21) International Application Number:
PCT/US2007/074320

(22) International Filing Date: 25 July 2007 (25.07.2007)

(25) Filing Language: English

(26) Publication Language: English

(30) Priority Data:
11/492,423 25 July 2006 (25.07.2006) US(71) Applicant: POWER SYSTEMS MFG., LLC [US/US];
1440 West Indiantown Road, Jupiter, FL 33458 (US).(72) Inventors: BIONDO, Charles; 5663 Holly Lane, Jupiter,
FL 33458 (US). STROHL, J., Page; 2443 S.W. Impala
Way, Stuart, FL 34997 (US). SAMUELSON, Jeffery, W.;
324 River Edge Road, Jupiter, FL 33477 (US). FUCHS,
Gerhard, E.; 9331 SW 33rd Road, Gainesville, FL 32608
(US). WLODEK, Stanley, T. (deceased). WLODEK, Ra-
mona, T. (heirress of the deceased inventor); 17810 Pueblo
Vista Lane, San Diego, CA 92127 (US).(74) Agents: MACK, Brian, R. et al.; Shook, Hardy & Bacon
L.L.P., 2555 Grand Blvd., Kansas City, MO 64108-2613
(US).(81) Designated States (unless otherwise indicated, for every
kind of national protection available): AE, AG, AL, AM,
AT, AU, AZ, BA, BB, BG, BH, BR, BW, BY, BZ, CA, CH,
CN, CO, CR, CU, CZ, DE, DK, DM, DO, DZ, EC, EE, EG,
ES, FI, GB, GD, GE, GH, GM, GT, HN, HR, HU, ID, IL,
IN, IS, JP, KE, KG, KM, KN, KP, KR, KZ, LA, LC, LK,
LR, LS, LT, LU, LY, MA, MD, ME, MG, MK, MN, MW,
MX, MY, MZ, NA, NG, NI, NO, NZ, OM, PG, PH, PL,
PT, RO, RS, RU, SC, SD, SE, SG, SK, SL, SM, SV, SY,
TJ, TM, TN, TR, TT, TZ, UA, UG, UZ, VC, VN, ZA, ZM,
ZW.(84) Designated States (unless otherwise indicated, for every
kind of regional protection available): ARIPO (BW, GH,
GM, KE, LS, MW, MZ, NA, SD, SL, SZ, TZ, UG, ZM,
ZW), Eurasian (AM, AZ, BY, KG, KZ, MD, RU, TJ, TM),
European (AT, BE, BG, CH, CY, CZ, DE, DK, EE, ES, FI,
FR, GB, GR, HU, IE, IS, IT, LT, LU, LV, MC, MT, NL, PL,
PT, RO, SE, SI, SK, TR), OAPI (BF, BJ, CF, CG, CI, CM,
GA, GN, GQ, GW, ML, MR, NE, SN, TD, TG).**Published:**

- with international search report
- before the expiration of the time limit for amending the
claims and to be republished in the event of receipt of
amendments

[Continued on next page]

(54) Title: NICKEL-BASE ALLOY FOR GAS TURBINE APPLICATIONS

Typical Blade Creep Rupture Life (Equiaxed)

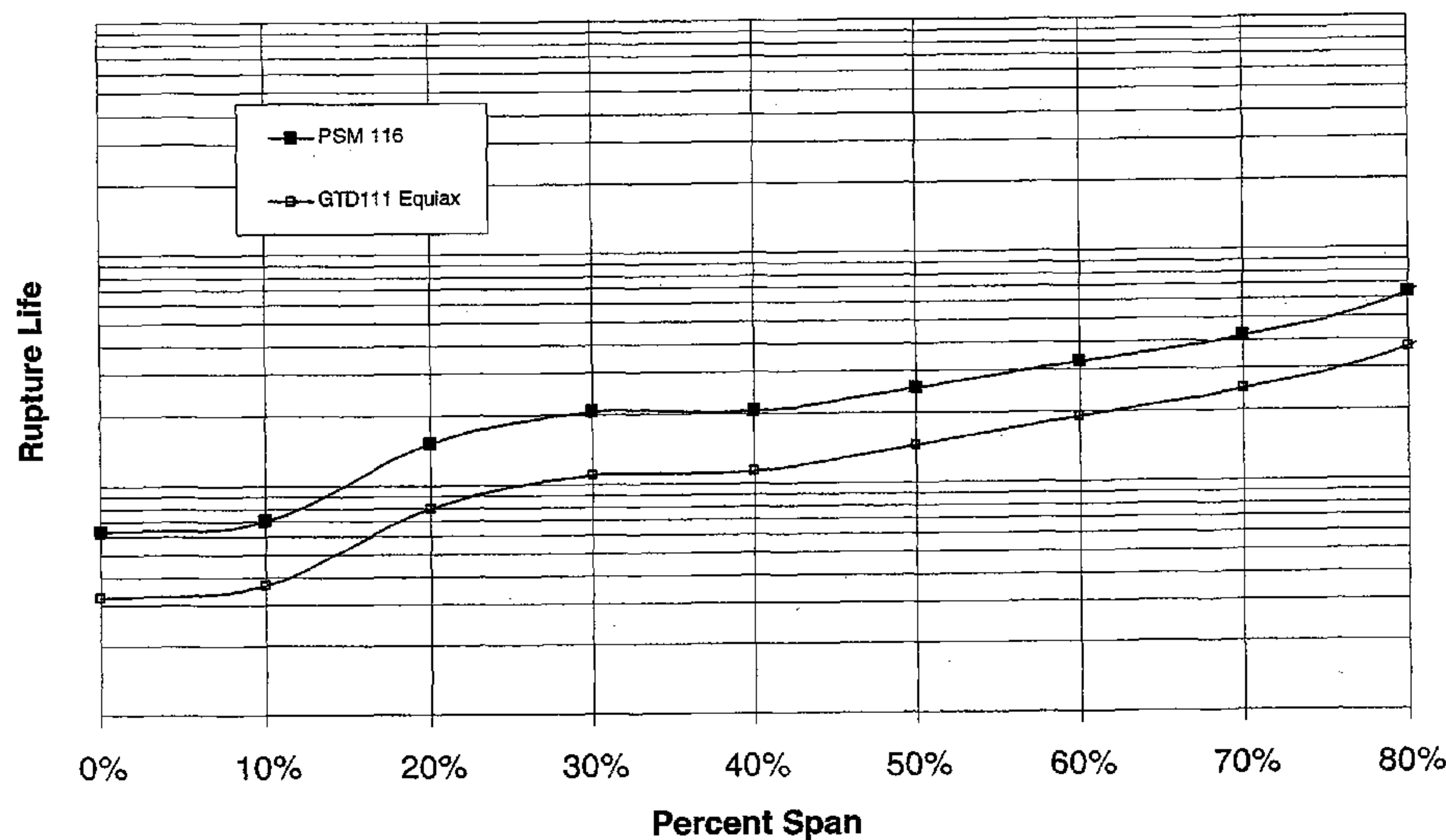

FIG.12

(57) Abstract: A nickel-based alloy suitable for casting gas turbine components having a lower density and basic heat treating process while achieving improved strength is disclosed. Multiple embodiments of the alloy are disclosed capable of providing both directionally-solidified and equiaxed castings. Also disclosed is a method of making a cast and heat treated article utilizing the improved nickel-base alloy.

WO 2008/091377 A3

WO 2008/091377 A3



(88) Date of publication of the international search report:
24 December 2008

NICKEL-BASE ALLOY FOR GAS TURBINE APPLICATIONS

FIELD OF THE INVENTION

The present invention relates to gas turbines. More particularly, embodiments
5 of the present invention relate to nickel-based alloys for use in casting gas turbine components.

BACKGROUND OF THE INVENTION

Gas turbine engines are known to operate in extreme environments exposing
the engine components, especially those in the turbine section, to high operating temperatures
10 and stresses. In order for the turbine components to endure these conditions, it is necessary
that they are manufactured from a material having properties capable of withstanding
prolonged exposure to such elevated temperatures and operating stresses, while receiving
adequate cooling to lower their effective operating temperatures. This is especially true for
the turbine buckets, or blades, as well as nozzles, or vanes, which are directly in the hot gas
15 path stream of a combustion section.

In an effort to improve the efficiency of a gas turbine engine, operating
temperatures can be increased in the combustion section so as to more completely burn the
fuel. As a result, the temperatures in the turbine section are increased as well. For turbine
materials to operate at a higher temperature without compromising component integrity,
20 either additional cooling to the turbine components or improved material capability is
required. However, by redirecting air to cool turbine components, the amount of air available
for the combustion process is reduced, lowering its efficiency. This is counter productive to
the goal of improving gas turbine efficiency by raising the operating temperature. Therefore,
it is desirable to provide the operating improvements without reducing present air flow levels
25 and engine efficiency.

A result of increased firing temperatures is further structural change in the
material. That is, as operating temperatures increase for a given material, its ability to bear
load decreases. As operating temperatures for gas turbine engines have increased over time
in order to improve engine efficiency, a number of materials have been introduced having
30 improved temperature capability. One such example is an alloy commonly referred to as

CM-247 produced by Cannon-Muskegon Corporation of Muskegon, Michigan. A form of this alloy is disclosed in U.S. Patent No. 4,461,659. This alloy is one of many that have been developed having improved strength by reducing grain boundary cracking.

Another alloy improvement for gas turbine applications was developed by The
5 General Electric Company. GTD-111, a nickel-based alloy having improved hot corrosion resistance, was developed for use in producing gas turbine blades and vanes. Properties of this alloy are disclosed in U.S. Patent Nos. 6,416,596 and 6,428,637.

Furthermore, in addition to improved alloys, casting techniques have been developed to improve the strength of buckets and nozzles and other gas turbine components.
10 As one skilled in the art of gas turbine airfoils will understand, the strength of a poured casting, and any inherent weakness therein, are a function of the size and location of the boundaries between the grains of the casting. Specifically, casting techniques have evolved from a conventional, or equiaxed, process where a metal is poured and grain boundaries are free to form as the part cools, to a directionally solidified (DS) casting process where metal is
15 poured and cooled in a manner so as to only form grain boundaries in a single direction, preferably so that the <001> crystallographic direction is parallel to the longitudinal direction of the airfoil. By aligning the grain boundaries, typically the weakest portion of a casting, in a direction generally perpendicular to the load on the airfoil, significant improvements in casting strength, ductility, and resistance to thermal fatigue are realized. Most recently,
20 enhancements have been made in the casting process so as to eliminate the grain boundaries altogether by cooling the castings in a manner so as to form a single crystal, or grain, structure, thereby eliminating the grain boundaries. This type of casting is the strongest type of casting to date, however, it is the most expensive casting to manufacture, due to the various processing requirements and alloy costs. Typically, single crystal castings are limited
25 to applications where extremely high temperatures are found, excessively high mechanical loads exist, or turbine geometry dictates such a casting. An additional issue with respect to the casting process and alloy utilized pertains to the required processing. That is, depending on the casting technique and alloy involved, time consuming and expensive processes must occur to form the turbine component of that particular alloy.

30 Although significant enhancements have been made in alloy development, cooling technology, and casting processes, there is still significant margin for further improvements. Specifically, there is an industry need for an alloy having at least the

79291-216

- 3 -

capabilities of state-of-the-art alloys, yet have improved tensile strength, better castability, reduced operating stresses, and lower manufacturing costs.

SUMMARY OF THE INVENTION

The present invention provides embodiments of a nickel-based alloy suitable
5 for the production of gas turbine components having improved stability, mechanical
properties, and lower operating stresses. One such stress reduction is found in the
longitudinal stress, which is a function of alloy density, which for the alloys disclosed herein
is lower than other well-known alloys used in gas turbine applications. Furthermore, the
nickel-based alloy undergoes a heat treatment process without the use of excessively long
10 high-temperature furnace schedules while also having a greater window at which such heat
treatment can occur.

Compositions of nickel-based alloys suitable for multiple forms of investment
casting are disclosed. This includes a composition suitable for equiaxed casting and for
directionally solidified (DS) casting. In a further aspect of the present invention, a method of
15 making a cast and heat treated article from the nickel-based alloy is provided comprising of
the elemental composition as well as the heat treatment process.

According to another aspect of the present invention, there is provided a
nickel-based alloy having a density of less than 0.30 pounds per cubic inch suitable for casting
lower longitudinally-stressed gas turbine components consisting essentially of the following
20 composition by weight percent:

aluminum 3.3 – 3.7;

titanium 4.0 – 5.15;

tantalum 2.4 – 3.0;

chromium 11.9 – 12.1;

25 cobalt 11.9 – 12.0;

79291-216

- 3a -

iron 0.0 - 0.15;

copper 0.0 - 0.10;

tungsten 3.0 – 3.7;

5 molybdenum 1.8 – 1.9;

carbon 0.04 - 0.12;

boron 0.010 - 0.020;

zirconium 0.0 - 20 parts per million;

hafnium 0.0 - 0.05;

10 sulfur 0.0 - 0.0012;

nitrogen 0.0 - 25 parts per million;

oxygen 0.0 - 10 parts per million; and

the remainder nickel and incidental impurities;

15 wherein the nickel-based alloy has a solution heat treatment window of at least 150° F in which a majority of a gamma prime strengthening phase dissolves.

According to still another aspect of the present invention, there is provided a lower longitudinally-stressed gas turbine component nickel-based alloy casting, having a density of less than 0.30 pounds per cubic inch, the nickel-based alloy consisting essentially of the following composition by weight percent:

20 aluminum 3.3 – 3.7;

titanium 4.0 – 5.15;

79291-216

- 3b -

tantalum 2.4 – 3.0;

chromium 11.7-12.1;

cobalt 11.9 – 12.0;

iron 0.0 - 0.15;

5 copper 0.0 - 0.10;

tungsten 3.0 – 3.7;

molybdenum 1.8 – 1.9;

carbon 0.04 - 0.12;

boron 0.010 - 0.020;

10 zirconium 0.0 - 20 parts per million;

hafnium 0.0 - 0.05;

sulfur 0.0 - 0.0012;

nitrogen 0.0 - 25 parts per million;

oxygen 0.0 - 10 parts per million; and

15 the remainder nickel and incidental impurities;

wherein:

the nickel-based alloy has a solution heat treatment window of at least 150° F in which a majority of a gamma prime strengthening phase dissolves, and

the nickel-based alloy casting has a metallurgical stability factor, N_{v3} , of 2.31.

79291-216

- 3c -

According to yet another aspect of the present invention, there is provided a method of making a cast and heat treated article of a nickel-based alloy comprising:

providing the alloy consisting essentially of the following composition by weight percent:

- 5 aluminum 3.3 - 3.82,
 titanium 3.5 - 5.15,
 tantalum 2.4 – 3.0,
 chromium 11.9 - 12.5,
 cobalt 11.9 - 12.0,
- 10 iron 0.0 - 0.15,
 copper 0.0 - 0.10,
 tungsten 3.5 – 5.0,
 molybdenum 1.8 – 1.9,
 carbon 0.04 - 0.12,
- 15 boron 0.010 - 0.020,
 zirconium 0.0 - 20 parts per million,
 hafnium 0.0 - 0.05,
 sulfur 0.0 - 0.0012,
 nitrogen 0.0 - 25 parts per million,
- 20 oxygen 0.0 - 10 parts per million, and

79291-216

- 3d -

the remainder nickel and incidental impurities;

elevating the alloy to 2050° F +/- 25° F and holding for 2 hours
+/- 15 minutes;

cooling the alloy by gas quench to below 1100° F;

5 elevating the alloy to 1975° F +/- 25° F and holding for 4 hours
+/- 15 minutes;

cooling the alloy by gas quench to below 1100° F;

elevating the alloy to 1550° F +/- 25° F and holding for 24 hours
+/- 30 minutes; and

10 cooling the alloy to below 1100° F,

wherein the alloy is melted to cast a gas turbine bucket, a nozzle, or a diaphragm such that an equiaxed casting is produced.

BRIEF DESCRIPTION OF THE DRAWING

The present invention is described in detail below with reference to the
15 attached drawing figures, wherein:

FIG. 1 is a chart depicting ultimate tensile strength and yield strength versus temperature for an alloy embodiment of the present invention compared to a prior art alloy.

FIG. 2 is a chart depicting stress rupture versus a normalized time and temperature parameter for an alloy embodiment of the present invention compared to prior art
20 alloys.

FIG. 3 is a cross section of a gas turbine engine identifying the location where buckets and nozzles in accordance with the present invention are present.

79291-216

- 3e -

FIG. 4 is a perspective view of a bucket formed from the superalloy in accordance with an embodiment of the present invention.

FIG. 5 is a perspective view of an alternate bucket formed from the superalloy in accordance with an embodiment of the present invention.

79291-216

- 4 -

FIG. 6 is a chart depicting ultimate tensile strength versus temperature for a directionally-solidified embodiment of an alloy of the present invention compared to a prior art alloy.

FIG. 7 is a chart depicting ultimate strength versus temperature for an equiaxed embodiment of an alloy of the present invention compared to prior art alloys.

FIG. 8 is a chart depicting yield strength versus temperature for an equiaxed embodiment of an alloy of the present invention compared to prior art alloys.

FIG. 9 is a chart depicting yield strength versus temperature for a directionally-solidified embodiment of an alloy of the present invention compared to a prior art alloy.

FIG. 10 is a chart depicting material elongation versus temperature for a directionally-solidified embodiment of an alloy of the present invention compared to a prior art alloy.

FIG. 11 is a chart depicting material elongation versus temperature for an equiaxed embodiment of an alloy of the present invention compared to prior art alloys.

FIG. 12 is a chart depicting creep rupture life of a blade fabricated from the equiaxed embodiment of an alloy of the present invention compared to a prior art alloy.

DETAILED DESCRIPTION OF THE INVENTION

The subject matter of the present invention is described with specificity herein to meet statutory requirements. However, the description itself is not intended to limit the scope of this patent. Rather, the inventors have contemplated that the claimed subject matter might also be embodied in other ways, to include different steps or combinations of steps similar to the ones described in this document, in conjunction with other technologies. Moreover, although the terms "step" and/or "block" may be used herein to connote different elements of methods employed, the terms should not be interpreted as implying any particular order among or between various steps herein disclosed unless and except when the order of individual steps is explicitly described.

The present invention provides a nickel-based alloy suitable for production of gas turbine components and method of making a cast and heat-treated nickel-based alloy. An exemplary embodiment of the present invention is described below.

- 5 -

For clarity purposes, it is best to identify some of the common terminology that will be discussed in greater detail with respect to embodiments of the present invention. A “gas turbine engine,” as the term is utilized herein, is an engine which provides mechanical output in the form of either thrust for propelling a vehicle or shaft power for driving an electrical generator. Gas turbine engines typically comprise a compressor, at least one combustor, and a turbine. A “blade”, as the term is utilized herein, is an airfoil attached to a disk that rotates about a shaft of the gas turbine engine. Blades are used to either compress air flow passing through a compressor or to rotate the disk, and shaft of a turbine, by way of air passing along the shaped airfoil surface. The term “blade” is often used interchangeably with “bucket,” and is done so herein, and is not meant to limit the nature of the term. A “vane,” as the term is utilized herein, is a stationary airfoil that is typically found in both compressor and turbine sections and serves to redirect the flow of air passing through a compressor or turbine. The term “vane” is often used interchangeably with “nozzle”, and is done so herein, and is not meant to limit the nature of the term. These types of airfoils are often cast from a liquid metal. Metal can be poured and cooled in a variety of means including to form equiaxed (EQ) and directionally-solidified (DS) castings. In an equiaxed casting, as one skilled in the art will understand, the casting is allowed to cool such that the grain boundaries of the solidified metal are free to form in any direction. In a DS casting, the metal is cooled in a direction so as to form a set of grain boundaries that extend in a specific direction.

An alloy having excellent casting properties, lower density and better stability has been developed by the inventors. The alloy has a range of acceptable chemistries, depending on the type of casting process to be utilized, each of which results in improved mechanical properties. This has been accomplished with chemistries that are free of expensive elements such as Rhenium (approximately \$800.00/lb.) or very reactive elements such as Zirconium and Hafnium.

The nickel-based alloy of the present invention, as originally conceived by the inventors, consists essentially of about the composition by weight as tabulated in Table 1 below:

Table 1 - Alloy Composition	
Element	Weight Percent
Aluminum	3.20 - 3.80
Titanium	4.00 - 5.30
Tantalum	2.20 - 2.70
Chromium	11.90 - 12.30
Cobalt	11.80 - 12.50
Iron	0.0 - 0.20
Copper	0.0 - 0.10
Tungsten	3.0 - 3.7
Molybdenum	1.80 - 2.00
Carbon	0.03 - 0.10
Boron	0.001 - 0.007
Zirconium	0.001 - 0.005
Hafnium	0.001 - 0.005
Sulfur	0.0 - 0.003
Nitrogen	0.001 - 0.007
Oxygen	0.003 - 0.010
Nickel	Remainder

5 The development of this alloy focused on identifying an effective nickel-base alloy free of expensive or overly reactive alloy additions, such that the alloy would be suitable for casting directionally solidified as well as equiaxed components. Initially seven chemistries were produced in directionally solidified cast slabs.

10 One area addressed during alloy development that is important with respect to the functionality of the alloy was its structural stability. Alloys undergo complex, solid phase reactions during service that can lead to the precipitation of embrittling phases. Controlling the alloy chemistry so as to negate the formation of these topologically close packed phases (TCP) can be achieved with some success by calculating the average electron vacancy per alloy atom, a value termed N_{v3} . The structural stability of an alloy is generally calculated

15 according to the equation: $N_{v3} = \sum_{i=1}^n m_i (N_v)_i$ per SAE AS 5491 Rev. B. The higher the N_{v3} ,

the less stable the alloy and more susceptible it is to TCP structures. Prior studies have shown, that even for the most stable alloys of this type, TCP phases can form if the $N_{v3} > 2.45$

79291-216

- 7 -

to 2.49. Some commercial alloys such as Rene 80 and Inconel 738 become unstable if the $N_{v3} > 2.32$ to 2.38.

The stability data of seven alloys (the compositions of which are detailed in Table 5 below) is listed below in Table 2. As it will be shown, depending on the form of the casting, the metallurgical stability factor, or structural stability, of the alloy ranges from 2.22 - 2.40.

Table 2 Stability of the First Round of Alloys.

<u>Alloy</u>	<u>Amount of TCP Phases Present After 1000 hours at 1400 F°</u>	<u>Amount of TCP Phases Present After 1000 hours at 1600 F°</u>	N_{v3}
1	None	Very Limited	2.19
2	None	None	2.31
3	Very Limited	Limited	2.38
4	None	None	2.16
5	Very Limited	Very Limited	2.26
6	None	None	2.17
7	None	Limited	2.28

Even though alloys 5 and 6 did not exceed the N_{v3} value of 2.32 where TCP phases are known to form, further review of specimens did reveal slight instabilities. Alloy 2, having a N_{v3} value of 2.31 showed the best results with respect to structural stability while showing no indications of TCP phases.

In order to increase the mechanical properties of the nickel-based alloy, it is necessary to heat treat the alloy. To heat treat a precipitation strengthened alloy such as a nickel base alloy of the present invention, one must first heat the alloy to a temperature close to the γ' solvus, the temperature above which the main strengthening phase γ' dissolves. This is commonly referred to as solutioning heat treatment. Subsequent exposure to a lower aging temperature will cause the strengthening γ' phase to precipitate in a manner that will increase mechanical properties. The strength of the alloy increases with the amount of γ' . Its distribution and lattice parameter are also factors that effect the degree of strength that can be imparted through γ' precipitation.

The heat treatment window, the difference between the solvus and solidus (temperature where melting starts) is greatly increased in the present invention. It is in this window in which the solutioning heat treatment must be performed in order to safely treat the part without it melting. Relatively small changes in amounts of Aluminum, Titanium, and Tantalum can cause rather large changes in γ' solvus. If the alloy contains higher levels of Aluminum, Titanium, or Tantalum, then the γ' solvus temperature increases, thereby

decreasing the heat treatment window. In order to determine the γ' solvus and solidus temperatures, differential thermal analyses (DTA) were performed. As one skilled in the art of materials engineering will understand, a DTA measures the difference in temperature between a sample and a thermally inert reference as the temperature is raised. The plot of this differential provides information on reactions taking place in the sample, including phase transitions, melting points, and crystallization. Some typical results of these analyses are shown below in Table 3.

Table 3 Heat Treatment Characteristics

Alloy	γ'Solvus F°	Solidus F°	Heat Treatment Window F°	Liquidus F°
2	2190	2343	153	2462
3	2188	2331	143	2448
7	2192	2327	135	2448

10

As it can be seen from the data above, the heat treatment window for Alloy 2, the most structurally stable of the alloys, also had a large heat treatment window, approximately 150 degrees F. Depending on the alloy composition, the heat treatment window can range from 120 – 160 degrees F. Such a large window indicates that the alloy can be heat treated safely under production conditions, without encountering the possibility of melting. This is especially critical, because often times heat treating large parts in large batches cannot be done with very accurate temperature control, often times varying as much as +/- 25 degrees F.

Another benefit of heat treating the alloy of the present invention is with respect to its tensile and creep rupture properties. It has been determined that no appreciable benefit is realized by solution heat treating the present invention alloy at higher temperatures or subjecting it to more complex aging treatments, as is the case for other high-temperature nickel-based alloys. The alloys developed through the present invention were heat treated by solutioning at 2050 deg. F. +/- 25 deg. F. for 2 hours +/- 15 minutes, followed by a cooling gas quench to below 1100 deg. F.. The quenching preferably occurs in a gas environment selected from the group comprising Argon, Helium, and Hydrogen. The alloys were then elevated to 1975 deg. F. +/- 25 deg. F. and aged for 4 hours +/- 15 minutes followed by a gas quench cooling back to below 1100 deg. F. Finally, the alloy is elevated to 1550 deg. F. +/- 25 deg. F. and stabilized for 24 hours +/- 30 minutes followed by a cooling to below 1100

20
25

deg. F., but most likely a room temperature. This heat treat cycle occurs at a relatively low temperature and involves fewer cycles, compared to those of other well-known alloys, thereby making this cycle a very economical heat treatment cycle. This is better understood by comparing the heat treat cycles disclosed herein to those of other similar alloys as shown in Table 4 below.

Table 4 Heat Treatment Requirements of Some Commercial Alloys

Alloy	Present Invention	GTD 404	CM 247 LC
Applicable Patent		US 6,908,518	US 4,461,659
Heat Treatment	2 hours, 2050 °F + 4 hours 1975 °F + 24 hours 1550 °F	Heat to 1400 °F for 10 minutes + heat to 2225°F hold 8 hours + heat to 2230 °F hold 4 hours + heat to 2280 °F hold 2hours. The slow heating and cooling rates stipulated add further furnace time.	2 hours 2250 °F + 2 hours 2300 °F + 5 hours 2174 °F + 4 hours 1976 °F + 20 hours 1600 °F

Depending on the type of gas turbine component being cast, the timing of the heat treat cycles may vary. For example, if a gas turbine blade or vane is to be coated with a thermal barrier coating (TBC) for additional protection from high operating temperatures, then the second and third steps in the heat treating process may occur after the TBC has been applied. The step of elevating the alloy to 1975 deg. F. +/- 25 deg. F and holding for 4 hours also serves to treat the coating as part of the coating process.

Another important feature of the present invention, is its density. As one skilled in the art of gas turbine airfoils will understand, the longitudinal stress on an airfoil is proportional to the density squared, or [stress $\sigma \propto (\text{density } \rho)^2$]. That is, the lower the alloy density used to produce the airfoil, the lower longitudinal stresses exhibited by the airfoil.

Specific densities for alloy 2 were both calculated and measured from sample castings. To more precisely calculate the density in this particular chemistry range, an equation has been developed. This equation is not sensitive to Cobalt and Chromium levels and is defined as:

$$D = 0.307667639 + (\% Mo)(0.000452137) + (\% W)(0.001737591) - (\% Al)(0.004497133) - (\% Ti)(0.001240936) + (\% Ta)(0.002133375) \quad \text{with } \% Mo$$

equaling the percentage by weight of Molybdenum, $\%W$ equaling the percentage by weight of Tungsten, $\%Al$ equaling the percentage by weight of Aluminum, $\%Ti$ equaling the percentage by weight of Titanium, and $\%Ta$ equaling the percentage by weight of Tantalum.

The degree of fit of the equation is excellent as can be seen by comparing measured densities of the sample casting to the calculated densities as shown in Table 5 below.

Table 5 Density of Experimental Alloys

5

	Cr	Co	Mo	W	Al	Ti	Ta	Measured Density Lbs/in ³	Calculated Density Lbs/in ³
Alloy 2	12	12	1.9	5	3.82	3.5	3	0.30259	0.30209
Alloy 3	12	10	2.5	5.45	3.72	3.5	4	0.30552	0.30572
Alloy 7	12	12.1	1.5	3.8	3.06	4.95	2.9	0.30129	0.30123
Alloy 1	12.5	9	1.9	3.9	3.6	3.5	2.9	0.30068	0.30095
Alloy 2 *	11.9	12	1.9	4.8	3.5	3.5	2.9	0.30270	0.30297
Alloy 4*	10.1	11.9	2.5	5.3	3.1	4.1	3.4	0.30604	0.30623
Alloy 5*	12.1	9.5	3	4.4	2.8	4.6	3.4	0.30591	0.30562
Alloy 6*	10.9	11.9	2.5	4.4	3.4	3.6	3.4	0.30414	0.30393
Alloy 2A	12.1	12	1.5	3.3	3.6	4.6	2.5	0.29756	0.29751
Alloy 2B	12.1	12	1.5	3	3.7	4.1	2.9	0.29832	0.29801
Alloy 2C	11.9	11.9	1.9	3.5	3.3	5.1	2.4	0.29846	0.29855
Alloy 2D	12	11.9	2	3	3.5	4.6	2.9	0.29818	0.29852

* Cast using an alternate supplier

As previously discussed, the density of this new alloy is significant because of the lower inherent operating stresses. The density of the alloy in the present invention is less than or equal to 0.30 lb./in³. The lower density level of this alloy can be better appreciated when compared to other alloys commonly used in gas turbine applications as shown in Table 6 below.

10

Table 6 Densities of Various Gas Turbine Alloys

<u>ALLOY</u>	<u>Density gm/cm³</u>	<u>Density Lbs/in³</u>
PWA 1484	8.8	0.323
PWA 1480	8.7	0.314
CMSX- 4	8.7	0.314
Rene N5	8.6	0.312
CM 247 LC	8.54	0.308
GTD 404	8.4	0.307
GTD 111	8.3	0.300
Alloy 2C	8.24	0.298

15

Another important factor regarding alloy density pertains to the resulting component weight and frequency. The lower the density, the lower the weight of the component. For a turbine blade which is rotating, the blade attachment pulls on a disk, while

the blade is being held in the disk. This pull is a function of the blade weight. A lower weight blade will have less pull on the disk and as a result have lower attachment stresses.

The density also affects the natural frequency of an airfoil, whether it be a blade or a vane. As one skilled in the art will understand, the natural frequency of an airfoil is critical in that it must remain out of the critical frequency of the engine (60 Hz for an engine operating at 3600 revolutions per minute). Not only are the airfoils intended to be outside the operating frequency of the engine (60 Hz in this example), but also any order thereof (i.e. 120 Hz, 180 Hz). Present turbine blades fabricated from an alloy having a higher density have a natural frequency just above the frequency of the engine. If a blade or vane resides at the natural frequency of the engine, or any order thereof for a long period of time, failure of the blade can occur due to high cycle fatigue. Fabricating the turbine blades/vanes from a lower density alloy, not only reduces component weight, and attachment stress for blades, but also raises its natural frequency, which moves the blade or vane frequency further away from the engine frequency, thereby reducing the chance of high cycle fatigue failure.

Mechanical properties for two data points for the first round of alloys are shown below in Tables 7 and 8. Table 7 represents ultimate tensile strength (UTS) data and yield strength (YS) data at temperatures of 800 deg. F. and 1400 deg. F., while Table 8 represents creep-rupture data at 1400 deg. F. Each of these tables also include data referring to a "baseline." Comparisons are made in the following tables and figures between the alloys developed and a baseline alloy and GTD-111. The baseline is an alloy presently used by the assignee in certain airfoil productions, with the baseline having properties similar to that of GTD-111.

As previously discussed, a goal of this development program is to produce a stable alloy, having improved strength, that has improved castability, and lower manufacturing costs. Referring to Table 7, two casting trials of alloy 2 are highlighted as well as a baseline alloy. As it can be seen from the data, alloy 2 (both casting trials) has a UTS within approximately 3% of the baseline alloy at the lower temperature 800 deg. F., while having a higher YS. While alloy 7 has a greater UTS, it has a smaller heat treat window (135 deg. F. vs 153 deg. F. for alloy 2). Alloy 3 also has a smaller heat treat window than alloy 2 and has a lower UTS. Shortcomings in the other development alloys become apparent at higher operating temperatures.

At typical turbine operating temperatures, closer to 1400 deg. F., alloy 2 (both casting trials) have a UTS and YS greater than the baseline. Also, as previously discussed,

79291-216

- 12 -

alloy 2 was completely structurally stable and had the largest heat treat window, lending itself to better manufacturing conditions. As it can be seen, the other alloys at 1400 deg. F. either did not have the strength of alloy 2 or began to exhibit structural instabilities (TCP phases), as previously discussed in Table 2 and reproduced below.

5

Table 7 Alloy Casting Trial Mechanical Properties

Alloy	H/T	Orient	Temp (F)	UTS (KSI)	0.2 % YS (KSI)	% Elong.	ROA %	Stability	HT Window	TCP Phases	
										1400	1600
Baseline	A	Long	800	169.1	126.9	6.6	8.6				
PCC1	A	Long	800	161.3	130	7.7	13.1				
CC2	A	Long	800	164.7	127.3	10.5	17.2		153		
PCC2	A	Long	800	160.2	133.7	6.6	12.4				
CC3	A	Long	800	155.8	132.3	6.6	9.3		143		
PCC4	A	Long	800	164	132.8	7.3	10.9				
PCC5	A	Long	800	172.1	146.6	3.6	7.4				
PCC6	A	Long	800	165.5	135.8	8.7	12.7				
CC7	A	Long	800	173.4	134.8	5	9.7		135		

Baseline	A	Long	1400	151.8	121.3	16.4	23.2				
PCC1	A	Long	1400	158.5	135.3	6.9	10.4	2.19		None	Very Limited
CC2	A	Long	1400	164	139.7	20.8	33.3	2.31	153	None	None
PCC2	A	Long	1400	162.2	140.4	7.9	11.6				
CC3	A	Long	1400	163.6	127.5	14.3	20.4	2.38	143	Very Limited	Limited
PCC4	A	Long	1400	161.9	141.1	7	9.7	2.16		None	None
PCC5	A	Long	1400	167.5	NA	12.4	16.8	2.26		Very Limited	Very Limited
PCC6	A	Long	1400	159	136.3	5.1	8.2	2.17		None	None
CC7	A	Long	1400	155.9	129.2	21	38.2	2.28	135	None	Limited

In addition to strength of the various alloys, another measure of alloy capability is creep-rupture (see Table 8 below). Creep is a plastic deformation caused by slip occurring along crystallographic directions due to constant load/stress applied at an elevated temperature. Creep is typically measured in percent deformation and the number of hours necessary under the loading and temperature to cause the deformation. From the data in Table 8, it can be seen that the alloys generally showed improvement with respect to creep life and the number of hours for 0.5%, 1%, 2%, and 5% creep deformation. Although alloy 3 showed better creep life than alloy 2, alloy 3 had other shortcomings with respect to heat treat windows and structural stability, as shown in Table 7.

15

Table 8 Alloy Casting Trials Creep Rupture Data

Alloy	HT	Orient	Temp	Stress	Life Hours	Hours to Creep			
						°F	KSI	Hours	0.50%
Baseline	A	L	1400	85	301.9	9	32.25	103.5	221.5
1	A	L	1400	85	508.2	42.7	129.4	266.7	466
PCC2	A	L	1400	85	659.2	53.6	196.4	452.4	power
CC2	A	L	1400	85	1317.9	58	211.3	473	912.5
3	A	L	1400	85	1255.2	101.7	303.2	637.95	1169.5
4	A	L	1400	85	658.7	66.6	214.2	551.5	fail
5	A	L	1400	85	613	15.75	98.25	299.5	power
6	A	L	1400	85	517.7	34.7	123	312.2	power
7	A	L	1400	85	511.2	19.7	66.9	192.4	384.2

From this and other data, it was determined that alloy 2 was the preferred composition that provided the necessary strength, structural stability, and allowed for a more manufacturing-friendly process.

Further analysis and development of alloy 2 was then conducted to determine the final composition. More specifically, four small heats (30 lb heats) were cast as directionally solidified slabs and evaluated. These size heats were selected as being more representative of sizes and weights for typical gas turbine casting applications. For these heats, the electron vacancy number, N_{v3} , ranged from 2.220 – 2.280. The resulting chemistries of these four alloys is shown in the following Table 9.

Table 9 Chemistries of Alloy 2 Variations

Property	Alloy 2A	Alloy 2B	Alloy 2C	Alloy 2D
Al	3.59	3.63	3.31	3.57
Ti	4.53	4.02	4.98	4.50
Ta	2.59	3.00	2.54	3.05
Cr	11.97	11.93	11.78	11.87
Co	12.04	12.04	11.96	11.96
W	3.40	3.08	3.65	3.09
Mo	1.46	1.44	1.89	1.98
C	0.076	0.066	0.072	0.066
B	0.012	0.011	0.010	0.010
Zr	<10 ppm	<10 ppm	<10 ppm	<10 ppm
S	6 ppm	7 ppm	4 ppm	7 ppm
N	12 ppm	19 ppm	8 ppm	16 ppm
O	9 ppm	6 ppm	8 ppm	9 ppm
P	8 ppm	10 ppm	8 ppm	9 ppm
Re	<0.10	<0.10	<0.10	<0.10
V	<0.10	<0.05	<0.10	<0.05
N_{v3}	2.270	2.220	2.280	2.270

Mechanical properties of alloys 2A – 2D were compared to a baseline to determine a preferred alloy. Referring to Table 10 it can be seen that alloy 2C provided improved YS and UTS at 800 deg. F. over the baseline as well as improved YS in the transverse direction at 1400 deg. F. A plot of alloy 2C capability vs. GTD-111 is shown in FIG. 1. Stress rupture data for alloys 2C and 2D are compared to a baseline alloy and GTD-111 in FIG. 2. From this chart it can be seen that alloy 2C has greater stress rupture life than that of the baseline and in that way is similar to that of GTD-111.

Table 10 Tensile Properties of The Experimental Alloy 2 Variations of this Invention Compared to GTD 111 DS

10

Property	Alloy 2A	Alloy2B	Alloy 2C	Alloy 2D	GTD 111 DS
Longitudinal					
800°F YS ksi	125	124	134	135	130
800 °F UTS, ksi	177	180	179	179	170
800°F El %	7	7	5	5	
800°F RA %	14	15	13	13	
Longitudinal					
1400°F YS ksi	130	125	131	132	132
1400°F UTS, ksi	148	143	148	150	152
1400°F El %	8	7	10	8	
1400°F RA %	22	20	23	20	
Transverse					
1400°F YS ksi	114	109	119	113	104
1400°F UTS, ksi	133	131	136	133	140
1400°F El %	2	2	3	3	
1400°F RA %	5	6	5	8	
Longitudinal					
1600°F YS ksi	77	70	82	78	84
1600°F UTS, ksi	100	93	103	103	104
1600°F El %	16	29	13	12	
1600°F RA %	36	43	37	38	

Having determined that alloy 2 is the preferred alloy, and more particularly, that Alloy 2C is the preferred elemental composition, due to its improved tensile strength at 800 degrees F, it was desirable to verify that production-sized quantities of the alloy can be produced in both directionally solidified (DS) and conventional, or equiaxed, castings. To evaluate production sized castings, two 380lb. master alloy heats were produced. As one

15

skilled in the art of investment casting will understand, in order to cast a nickel-based alloy such as the present invention with different solidification techniques, DS versus equiaxed, it is necessary to modify the carbon content. Specifically, an equiaxed casting requires a greater carbon content, approximately 0.07 – 0.10%, whereas a DS casting only requires approximately 0.03 – 0.06%. For the sample heats cast in each configuration, the chemical analyses are shown below in Table 11.

Table 11 Chemical Analyses of 400 lb Production Heats

Property	2C-1 DS	2C-1 Conventional.
Al	3.54	3.56
Ti	5.08	5.1
Ta	2.5	2.5
Cr	12.0	12.2
Co	12.2	12.1
W	3.5	3.5
Mo	1.9	1.9
C	0.050	0.097
B	0.015	0.015
Zr	<10 ppm	< ppm
S	1 ppm	1 ppm
N	1 ppm	4 ppm
O	6 ppm	6 ppm
P	7 ppm	6 ppm
Re	< 0.10	<0.10
V	<0.005	<0.005
Nv ₃	2.400	2.390

Having concluded that Alloy 2C could be successfully cast in both DS and equiaxed styles, the next step in the alloy development was to shift from casting trial heats, to casting trial gas turbine components. A cross section of a typical gas turbine engine is shown in FIG. 3 with each section of the engine noted. For Alloy 2C, two blades from the turbine section compatible with each the General Electric Frame 7FA 2nd stage and 3rd stage turbine were cast. The 2nd stage blades are approximately 18 inches long and each weigh approximately 19 lbs. A diagram of this type of gas turbine blade is shown in FIG. 4. This blade is typically cast in a directionally solidified manner due to the operating temperatures and stress levels experienced by the blade. It is cast from CM 247, a nickel base alloy having a density higher than that of the alloy disclosed herein, details of which have previously been discussed and are disclosed in U.S. Patent No. 4,461,659. Average production yield (% of acceptable castings) for this airfoil cast in CM-247 is approximately 80%. Trial castings for

this stage turbine blade resulted in a 100% yield. Although the sample size was small, there were no indications that this yield would be any different in a production setting.

As for the 3rd stage blade, it is approximately 23 inches long and weighs approximately 26 lbs. A diagram of this type of gas turbine blade is shown in FIG. 5. This blade is typically cast in a conventional, or equiaxed, style from CM 247 as well. However, typical yield from this part is only approximately 20% when being cast from CM 247. Utilizing the alloy of the present invention raised the casting yield to 100%. Although the sample size was small, there were no indications that this yield would be any different in a production setting.

Through additional testing and analysis, slight modifications were made to the composition of alloy 2C to yield a more producible composition as well as to further improve the material capabilities. The resulting composition differs slightly between equiaxed and DS form, but are both covered by the alloy composition listed below in Table 12.

Table 12 - Alloy Composition	
Element	Weight Percent
Aluminum	3.35-3.65
Titanium	4.85-5.15
Tantalum	2.30 - 2.70
Chromium	11.50 - 12.50
Cobalt	11.50 - 12.50
Iron	0.0 - 0.15
Copper	0.0 - 0.10
Tungsten	3.3 - 3.7
Molybdenum	1.70 - 2.10
Carbon	0.04 - 0.12
Boron	0.010 - 0.020
Zirconium	0.0 - 20ppm
Hafnium	0.0 - 0.05
Sulfur	0.0 - 0.0012
Nitrogen	0.0 - 25ppm
Oxygen	0.0 - 10ppm
Nickel	Remainder

Through such analysis and testing, better understanding of the material capabilities for alloy 2C in both an equiaxed and directionally-solidified form were measured. The equiaxed form of alloy 2C was designated as PSM116 and the DS form of alloy 2C was designated as PSM117. PSM117 was analyzed with respect to both longitudinal and transverse directions. As one skilled in the art will understand, "longitudinal" or "long" refers to along the grain boundaries whereas "transverse" or "trans" is the direction 90

degrees to the grain direction. Modifications made to create the production form of the equiaxed and DS alloy included minor changes in elemental concentrations, some increasing, some decreasing. Upon mechanical testing of production specimens, it was determined that ultimate tensile strength improved over alloy 2C, and the prior art alloy GTD-111. This was true for both equiaxed and DS forms at the upper end of the operating spectrum of a turbine blade, greater than approximately 1200F (see FIGS. 6 and 7). As can be seen in FIG. 7, the equiaxed form of alloy of the present invention also has improved ultimate tensile strength over a majority of the temperature profile compared to prior art alloys Canon-Muskegon 247 and Inconel 738.

10 Furthermore, for the same operating spectrum, yield strength of the equiaxed alloy, PSM116, was also slightly improved over that of alloy 2C, prior art alloys GTD-111, CM-247, and IN-738 (see FIG. 8). Referring to FIG. 9, similar improvements in yield strength compared to prior art alloy GTD-111 can be seen for the DS specimens of the present invention alloy. These improvements in yield strength and ultimate strength at the upper end of the operating envelope are important since turbine blades fabricated from this alloy tend to operate at these higher temperatures (1200 deg. F. and higher).

Referring now to FIGS. 10 and 11, the elongation of the material under elevated temperature is shown respectively for directionally solidified and equiaxed forms of the present invention. In general, for both forms of the alloy, the percent elongation is greater at higher operating temperatures than at lower temperatures. Referring to FIG. 10, the DS form of the alloy has slightly more elongation than that of prior art alloy GTD-111. However, at higher operating temperatures, above approximately 1400F, the percent elongation of the DS form (PSM117) is less than that of GTD-111. It is this arrangement that is most desirable for gas turbine technology. For turbine blades and vanes which operate at higher temperatures, having smaller amounts of elongation is indicative of a stronger component. With regards to FIG. 11, the percent elongation versus temperature for the equiaxed form of the present invention alloy, PSM116, is shown. The percent elongation is higher for the equiaxed alloy across most of the temperature profile compared to the prior art alloys.

30 Referring to FIG. 12, an additional benefit from the alloy of the present invention is shown in terms of creep rupture life over percent span of the blade formed from the alloy. Life of the component is measured in terms of hours until rupture occurs. As it can be seen from FIG. 12, for a given temperature and mechanical load, the equiaxed form of

79291-216

- 18 -

alloy 2C, PSM116, shows improvement in rupture life (non-dimensional scale shown) from the route of a blade formed from the alloy to at least the 80% span location, compared to the equiaxed form of prior art alloy GTD-111.

5 In addition to the alloy composition being disclosed, a method of making a cast and heat treated article of a nickel-based alloy is disclosed comprising providing the alloy in accordance with the composition levels previously described and subjecting the alloy to the heat treating process previously disclosed.

10 The present invention has been described in relation to particular embodiments, which are intended in all respects to be illustrative rather than restrictive. Alternative embodiments will become apparent to those of ordinary skill in the art to which the present invention pertains without departing from its scope.

15 From the foregoing, it will be seen that this invention is one well adapted to attain all the ends and objects set forth above, together with other advantages which are obvious and inherent to the system and method. It will be understood that certain features and sub-combinations are of utility and may be employed without reference to other features and sub-combinations.

CLAIMS:

1. A nickel-based alloy having a density of less than 0.30 pounds per cubic inch suitable for casting lower longitudinally-stressed gas turbine components consisting essentially of the following composition by weight percent:
 - 5 aluminum 3.3 – 3.7;
titanium 4.0 – 5.15;
tantalum 2.4 – 3.0;
chromium 11.9 – 12.1;
cobalt 11.9 – 12.0;
 - 10 iron 0.0 - 0.15;
copper 0.0 - 0.10;
tungsten 3.0 – 3.7;
molybdenum 1.8 – 1.9;
carbon 0.04 - 0.12;
 - 15 boron 0.010 - 0.020;
zirconium 0.0 - 20 parts per million;
hafnium 0.0 - 0.05;
sulfur 0.0 - 0.0012;
nitrogen 0.0 - 25 parts per million;
 - 20 oxygen 0.0 - 10 parts per million; and

the remainder nickel and incidental impurities;

wherein the nickel-based alloy has a solution heat treatment window of at least 150° F in which a majority of a gamma prime strengthening phase dissolves.

2. The nickel-based alloy of claim 1, wherein the titanium represents greater than
5 5 percent by weight of the alloy and less than or equal to 5.15 percent by weight of the alloy.
3. The nickel-based alloy of claim 1 or 2, wherein the chromium represents
greater than 12 percent by weight of the alloy and less than or equal to 12.1 percent by weight
of the alloy.
4. The nickel-based alloy of any one of claims 1 to 3, which is solution heat
10 treated by:

elevating the alloy to 2050° F +/- 25° F and holding for 2 hours
+/- 15 minutes;

cooling the alloy by gas quench to 1100° F or below;

elevating the alloy to 1975° F +/- 25° F and holding for 4 hours
15 +/- 15 minutes;

cooling the alloy by gas quench to 1100° F or below;

elevating the alloy to 1550° F +/- 25° F and holding for 24 hours
+/- 30 minutes; and

cooling the alloy to 1100° F or below.
- 20 5. The nickel-based alloy of claim 4, wherein a thermal barrier coating is applied
to the alloy prior to the step of elevating the alloy to 1975° F +/- 25° F and holding
for 4 hours +/- 15 minutes.

6. The nickel-based alloy of claim 4, wherein a gas selected from the group consisting of argon, helium and hydrogen is used for the cooling.
7. The nickel-based alloy of any one of claims 1 to 6, which has a metallurgical stability factor, N_{v3} , of between 2.22 - 2.40.
- 5 8. A lower longitudinally-stressed gas turbine component nickel-based alloy casting, having a density of less than 0.30 pounds per cubic inch, the nickel-based alloy consisting essentially of the following composition by weight percent:
- aluminum 3.3 – 3.7;
 - titanium 4.0 – 5.15;
 - 10 tantalum 2.4 – 3.0;
 - chromium 11.7-12.1;
 - cobalt 11.9 – 12.0;
 - iron 0.0 - 0.15;
 - copper 0.0 - 0.10;
 - 15 tungsten 3.0 – 3.7;
 - molybdenum 1.8 – 1.9;
 - carbon 0.04 - 0.12;
 - boron 0.010 - 0.020;
 - zirconium 0.0 - 20 parts per million;
 - 20 hafnium 0.0 - 0.05;
 - sulfur 0.0 - 0.0012;

nitrogen 0.0 - 25 parts per million;

oxygen 0.0 - 10 parts per million; and

the remainder nickel and incidental impurities;

wherein:

- 5 the nickel-based alloy has a solution heat treatment window of at least 150° F in which a majority of a gamma prime strengthening phase dissolves, and

the nickel-based alloy casting has a metallurgical stability factor, N_{v3} , of 2.31.

9. A method of making a cast and heat treated article of a nickel-based alloy comprising:

- 10 providing the alloy consisting essentially of the following composition by weight percent:

aluminum 3.3 - 3.82,

titanium 3.5 - 5.15,

tantalum 2.4 - 3.0,

- 15 chromium 11.9 - 12.5,

cobalt 11.9 - 12.0,

iron 0.0 - 0.15,

copper 0.0 - 0.10,

tungsten 3.5 - 5.0,

- 20 molybdenum 1.8 - 1.9,

carbon 0.04 - 0.12,

boron 0.010 - 0.020,

zirconium 0.0 - 20 parts per million,

hafnium 0.0 - 0.05,

5 sulfur 0.0 - 0.0012,

nitrogen 0.0 - 25 parts per million,

oxygen 0.0 - 10 parts per million, and

the remainder nickel and incidental impurities;

elevating the alloy to 2050° F +/- 25° F and holding for 2 hours

10 +/- 15 minutes;

cooling the alloy by gas quench to below 1100° F;

elevating the alloy to 1975° F +/- 25° F and holding for 4 hours

+/- 15 minutes;

cooling the alloy by gas quench to below 1100° F;

15 elevating the alloy to 1550° F +/- 25° F and holding for 24 hours

+/- 30 minutes; and

cooling the alloy to below 1100° F,

wherein the alloy is melted to cast a gas turbine bucket, a nozzle, or a diaphragm such that an equiaxed casting is produced.

20 10. The method of claim 9, wherein:

the carbon represents 0.04 - 0.07 by weight percent of the alloy;

the sulfur represents up to 10 parts per million by weight percent of the alloy;
and

the nitrogen represents up to 10 parts per million by weight percent of the alloy.

5 11. The method of claim 9 or 10, wherein:

the titanium represents greater than 5 percent by weight of the alloy and less than or equal to 5.15 percent by weight of the alloy; and

the chromium represents greater than 12 percent by weight of the alloy and less than or equal to 12.5 percent by weight of the alloy.

10 12. The method of any one of claims 9 to 11, further comprising providing a thermal barrier coating to the nickel-based alloy prior to the step of elevating the alloy to 1975° F +/- 25° F and holding for 4 hours +/- 15 minutes.

13. The method of any one of claims 9 to 12, wherein the alloy has a heat treatment window of approximately 150° F.

15 14. The method of any one of claims 9 to 13, wherein a metallurgical stability factor, N_{v3} , of said alloy is 2.22 - 2.40.

15. The method of any one of claims 9 to 14, wherein the alloy has a density, in lbs per cubic inch, according to the equation:

$$D = 0.307667639 + (\%Mo)(0.000452137) + (\%W)(0.001737591) -$$

20 $(\%Al)(0.004497133) - (\%Ti)(0.001240936) + (\%Ta)(0.002133375)$

wherein:

%Mo is the percentage by weight of the molybdenum;

%W is the percentage by weight of the tungsten;

%Al is the percentage by weight of the aluminum;

%Ti is the percentage by weight of the titanium; and

%Ta is the percentage by weight of the tantalum.

16. The method of claim 15, wherein the density is less than or equal
5 to 0.30 lbs per cubic inch.

17. The method of any one of claims 9 to 16, wherein a gas selected from the
group consisting of argon, helium, and hydrogen is used for the cooling.

Alloy 2C vs. GTD-111: Ultimate Strength & Yield Strength

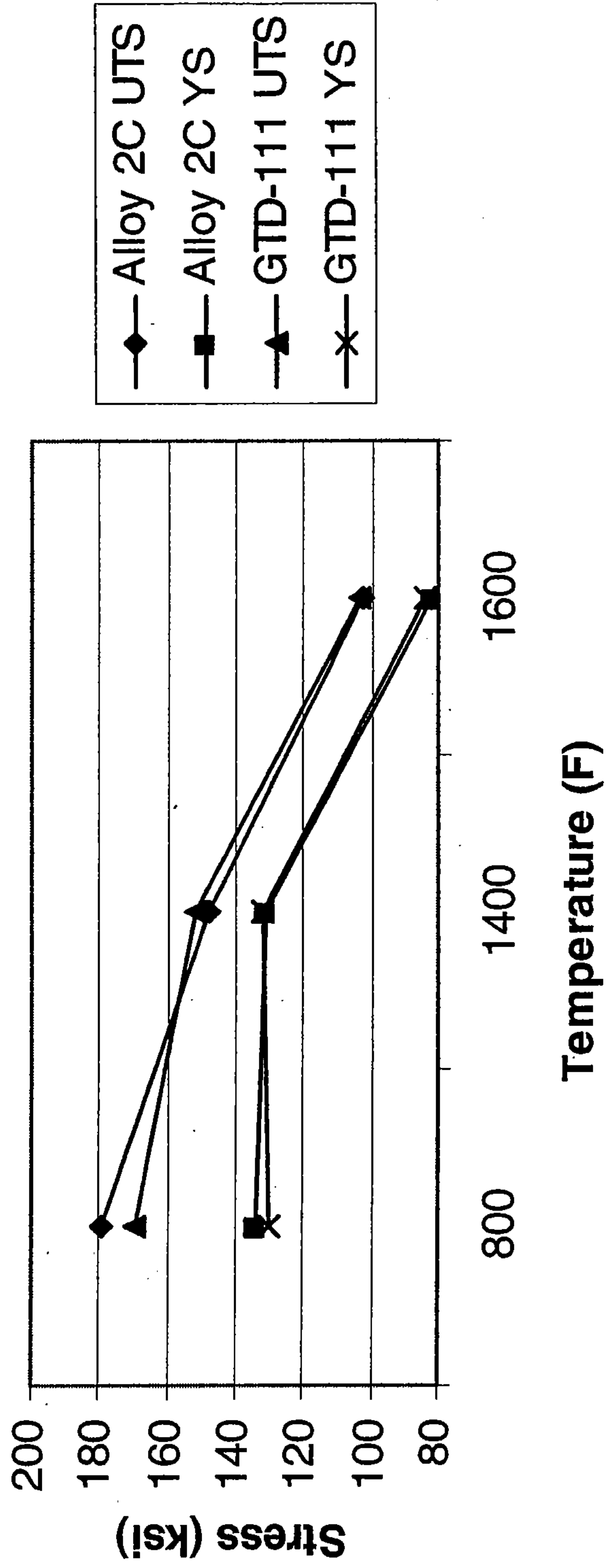

FIG. 1

Stress Rupture: Alloys 2C and 2D Vs. GTD-111/Baseline

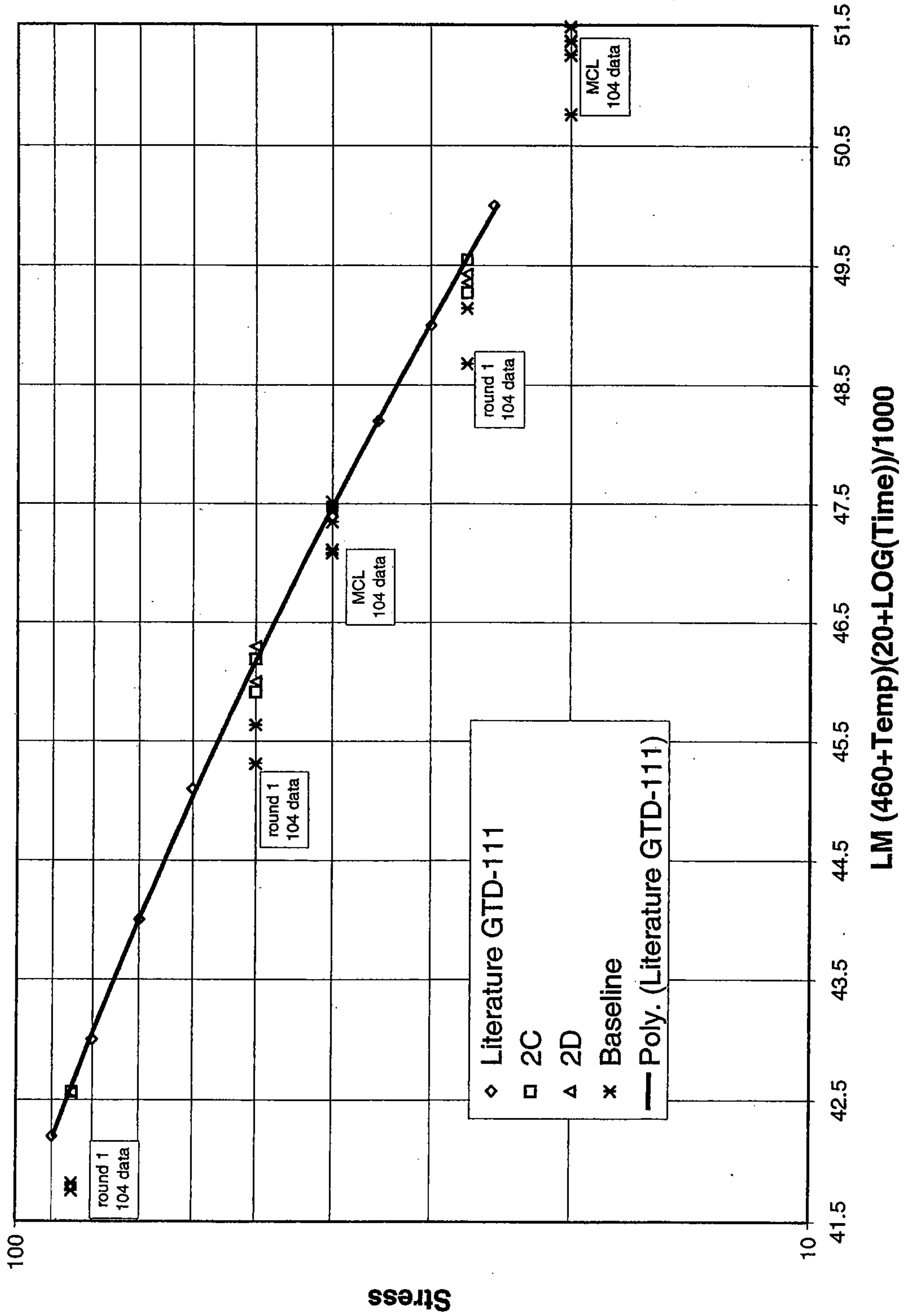

FIG. 2

3/12

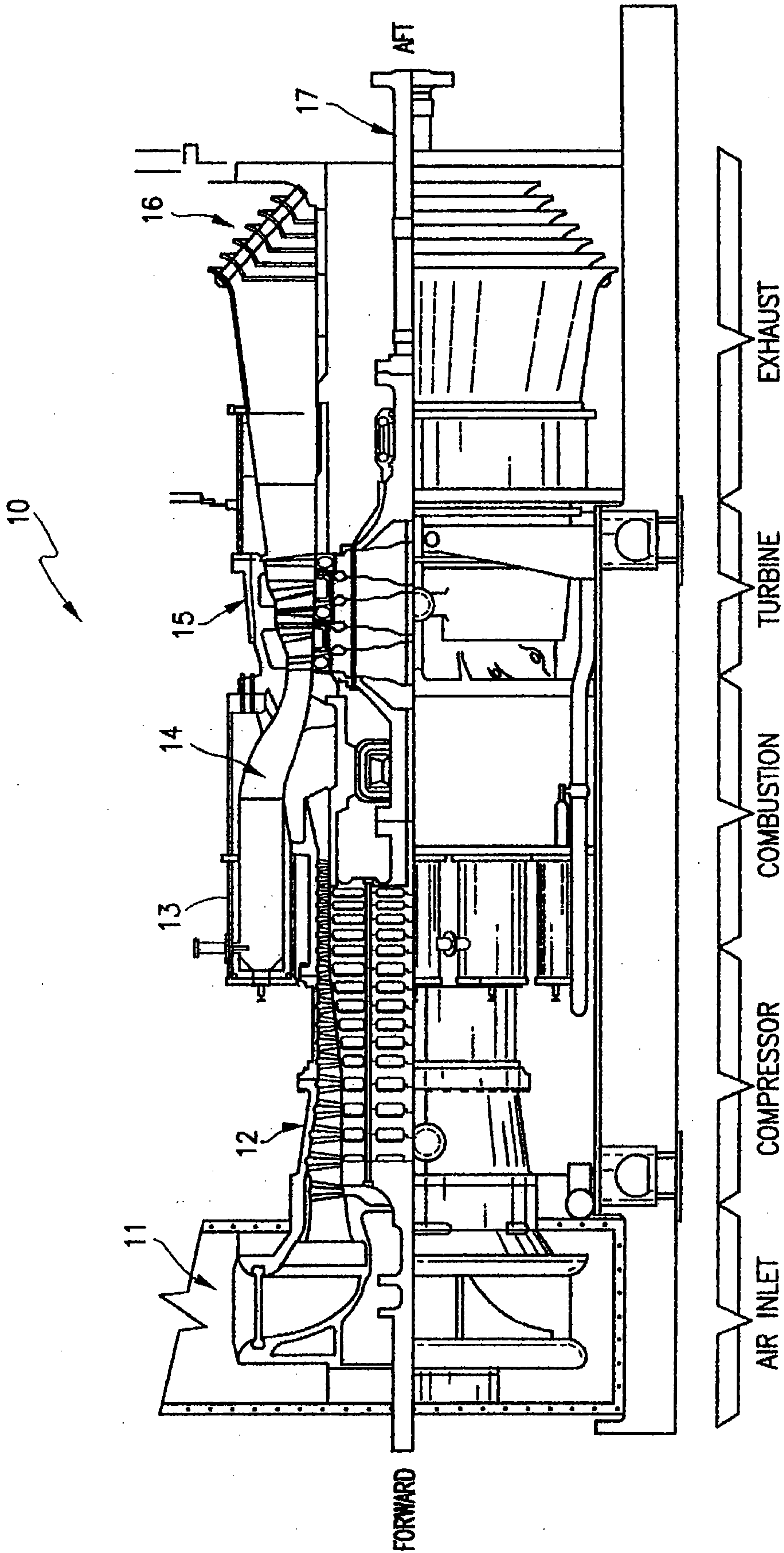
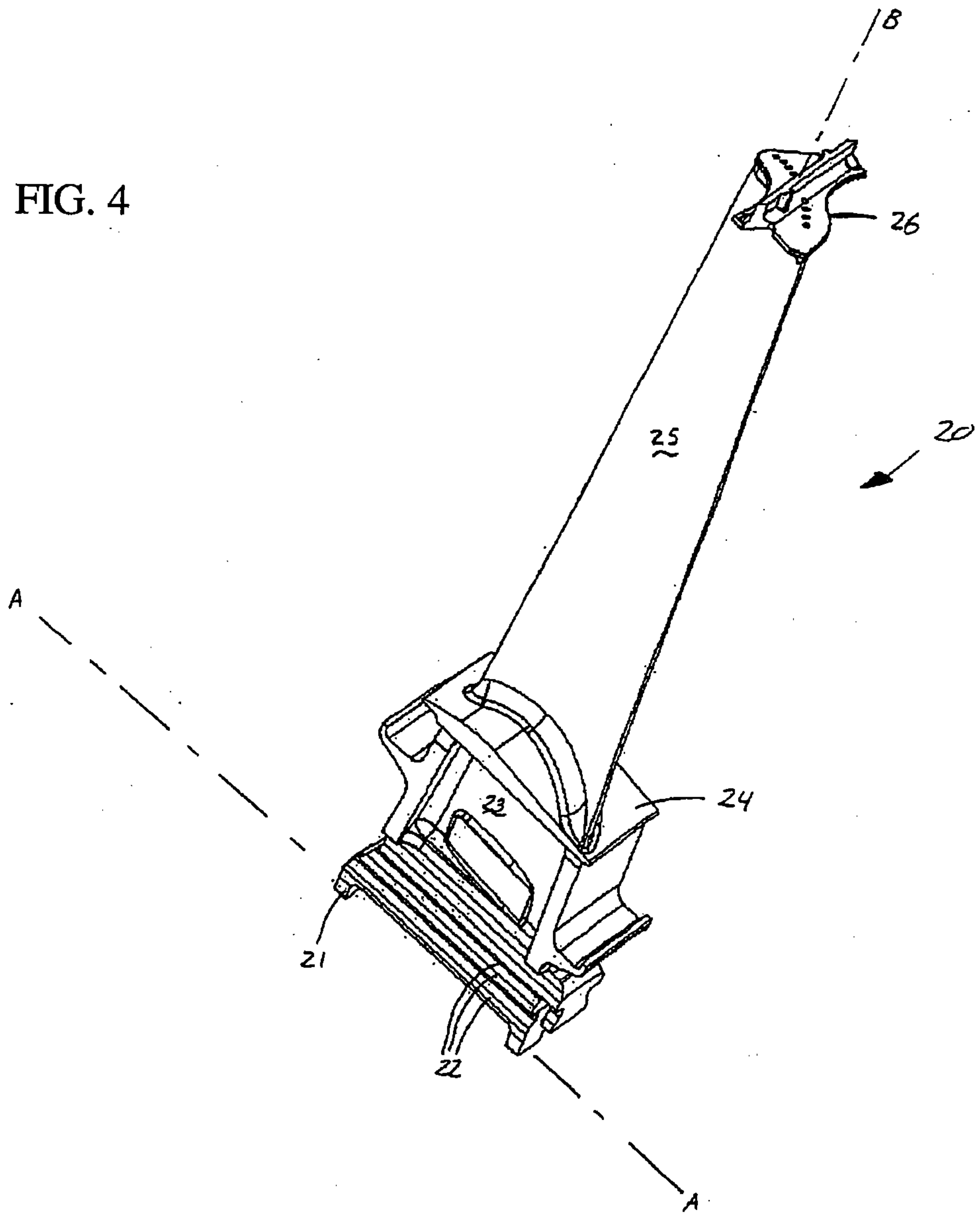

FIG. 3

FIG. 4



5/12

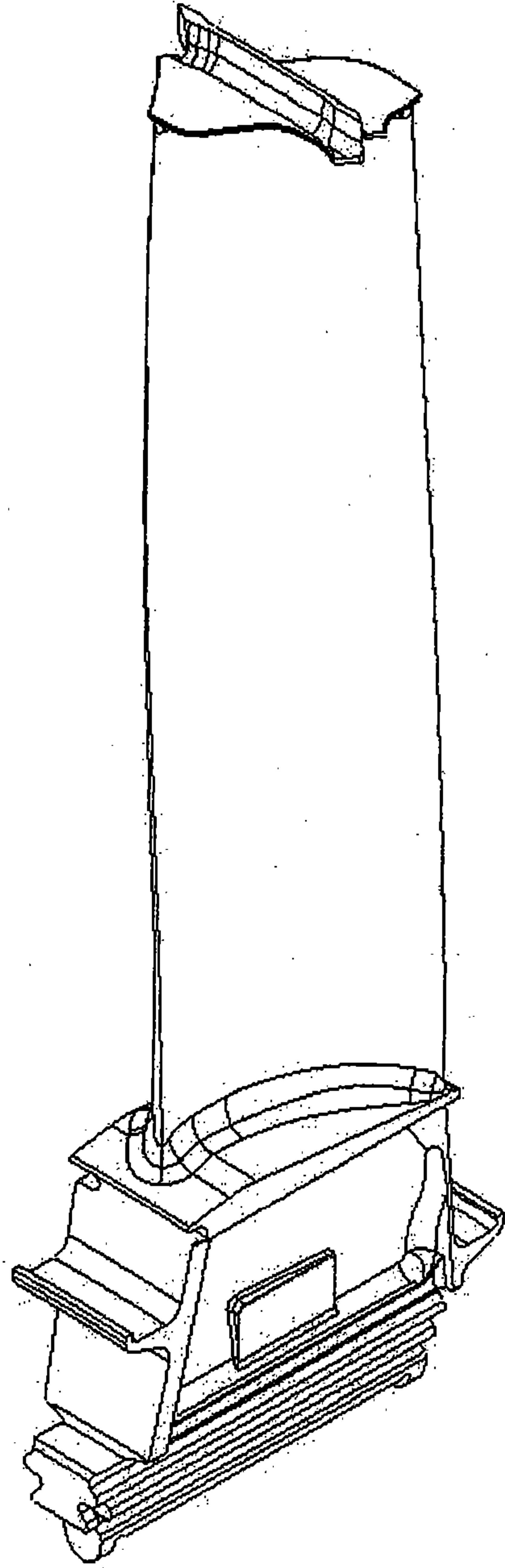

FIG. 5

6/12

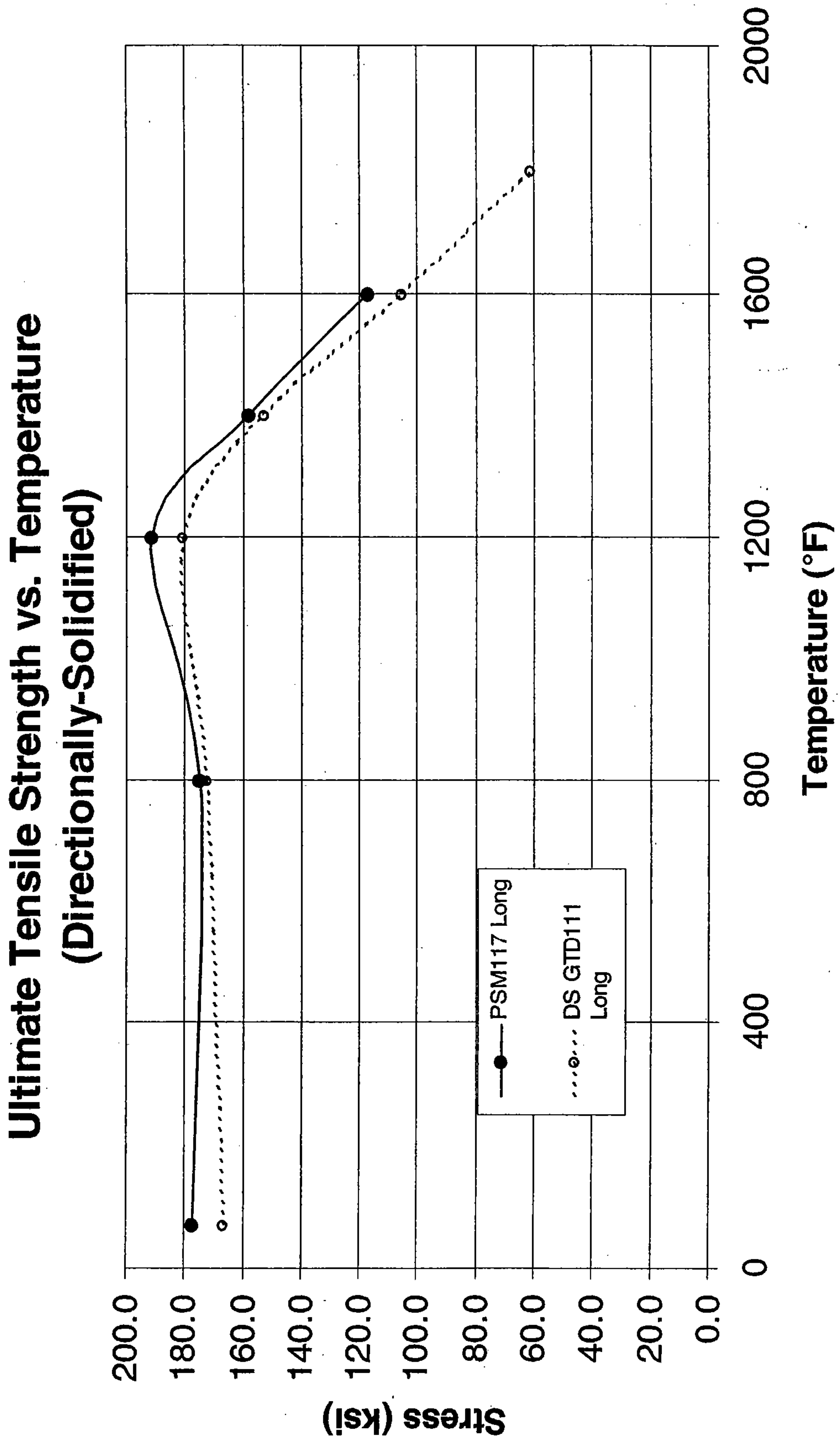

FIG. 6

Ultimate Tensile Strength vs. Temperature (Equiaxed)

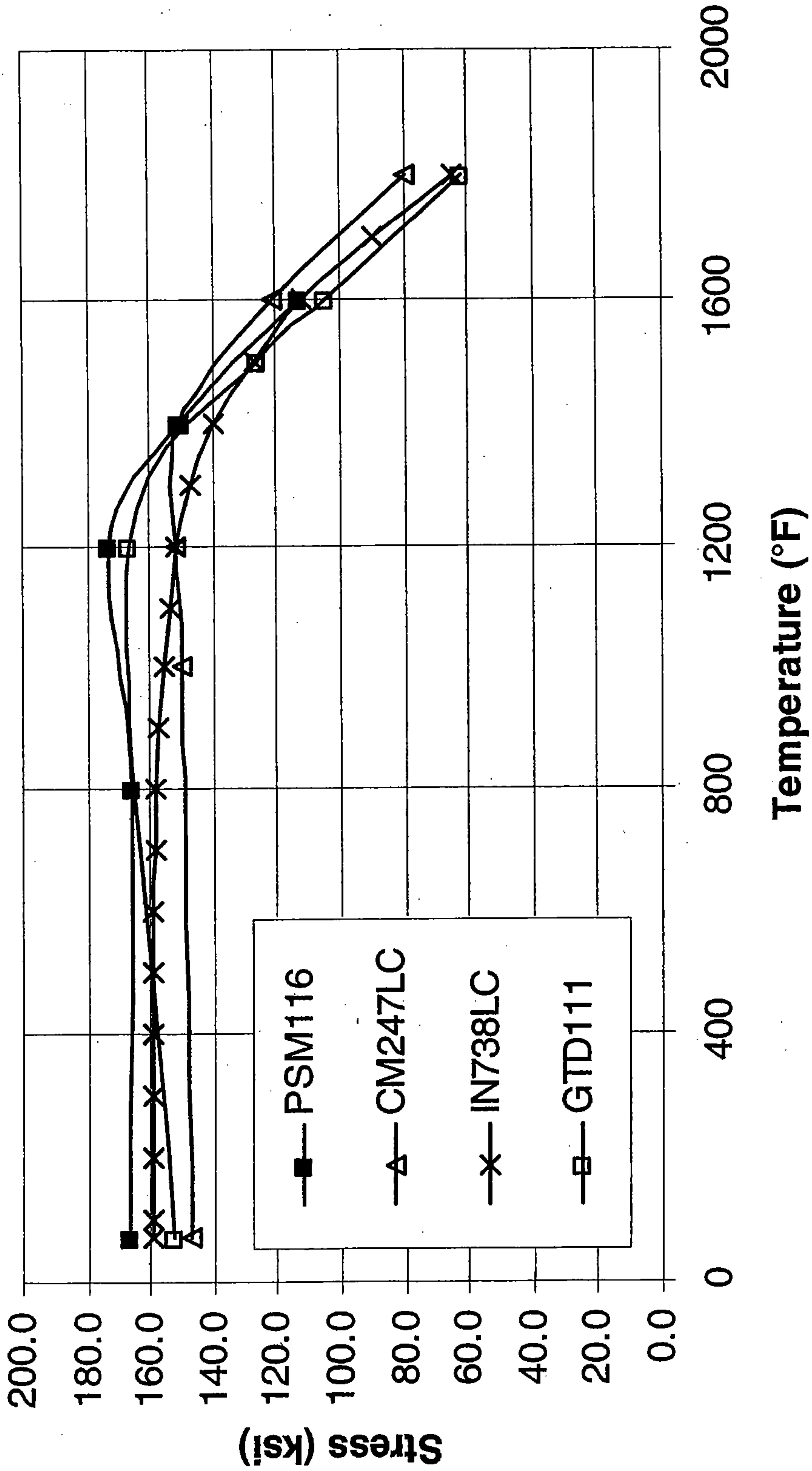

FIG. 7

8/12

0.2% Yield Strength vs. Temperature (Equiaxed)

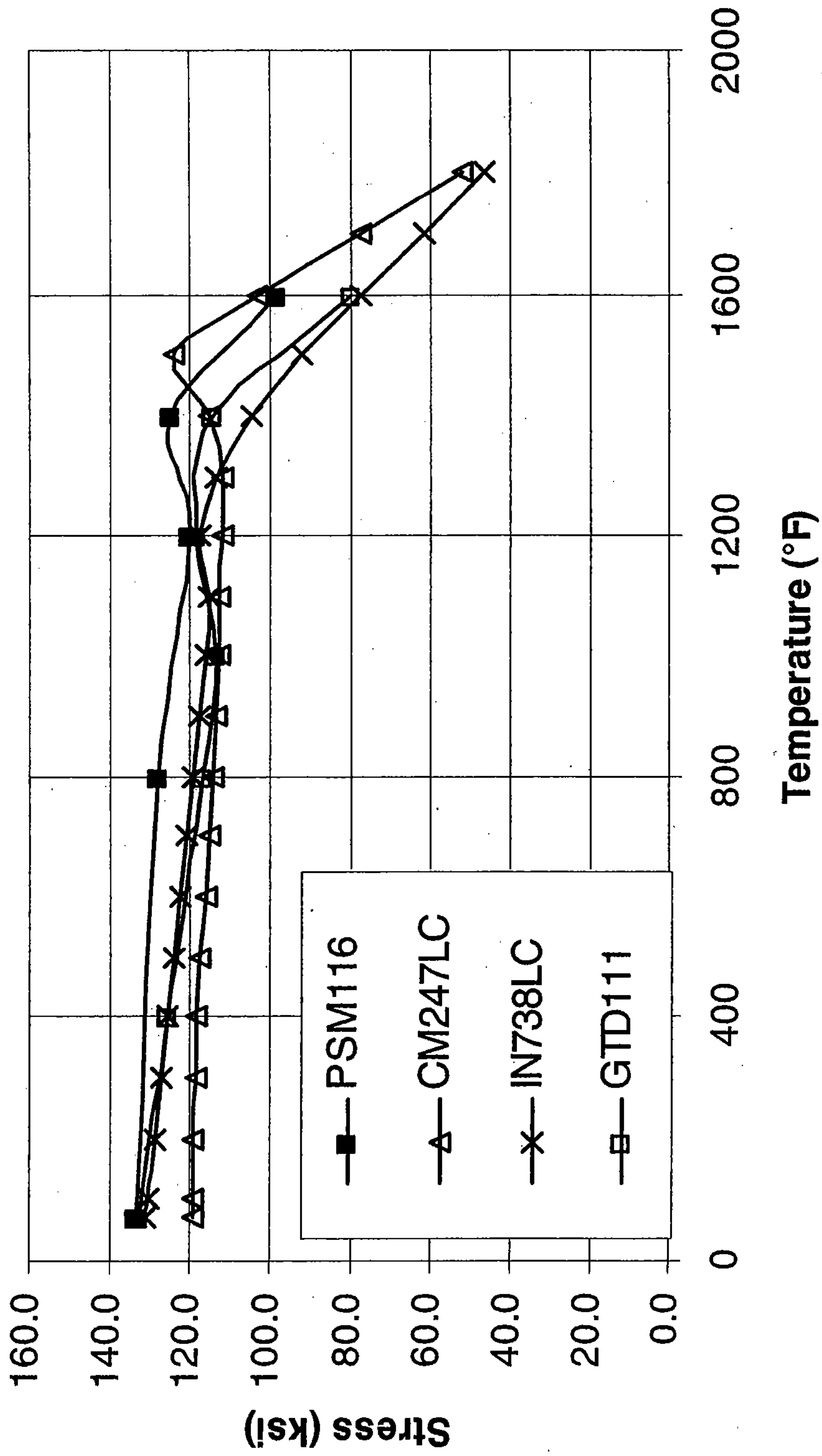

FIG. 8

9/12

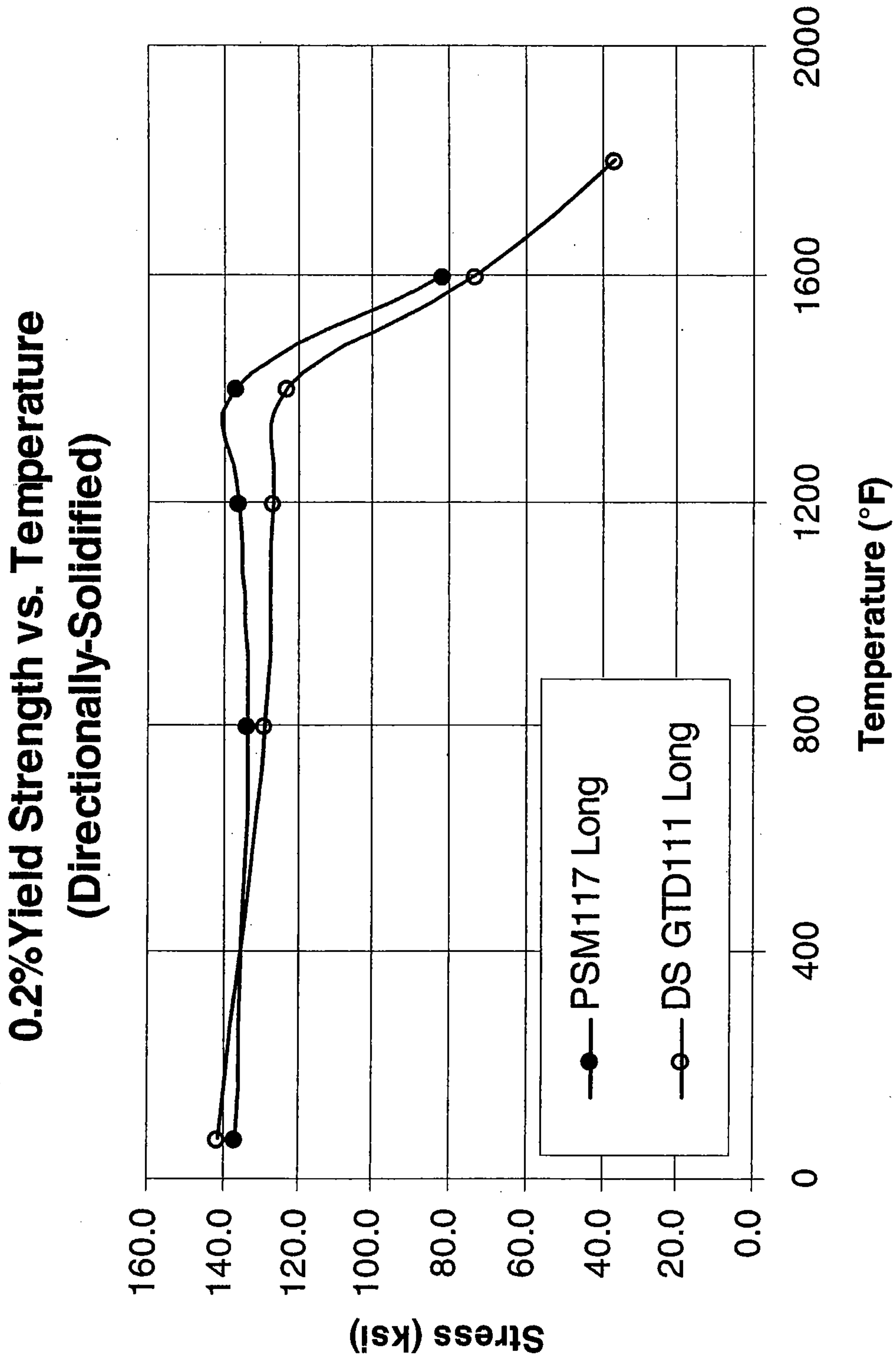

FIG. 9

10/12

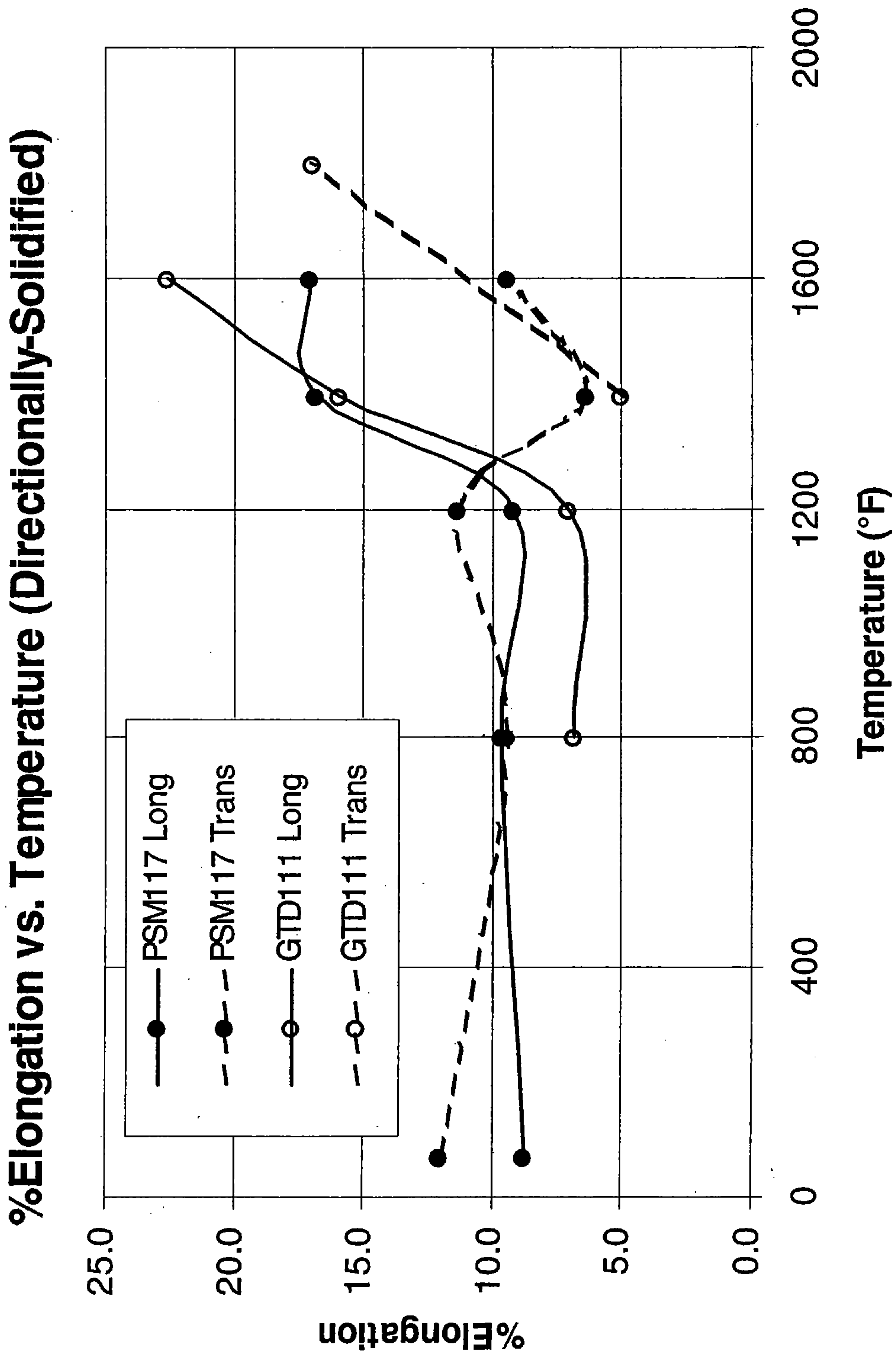

FIG.10

11/12

%Elongation vs. Temperature (Equiaxed)

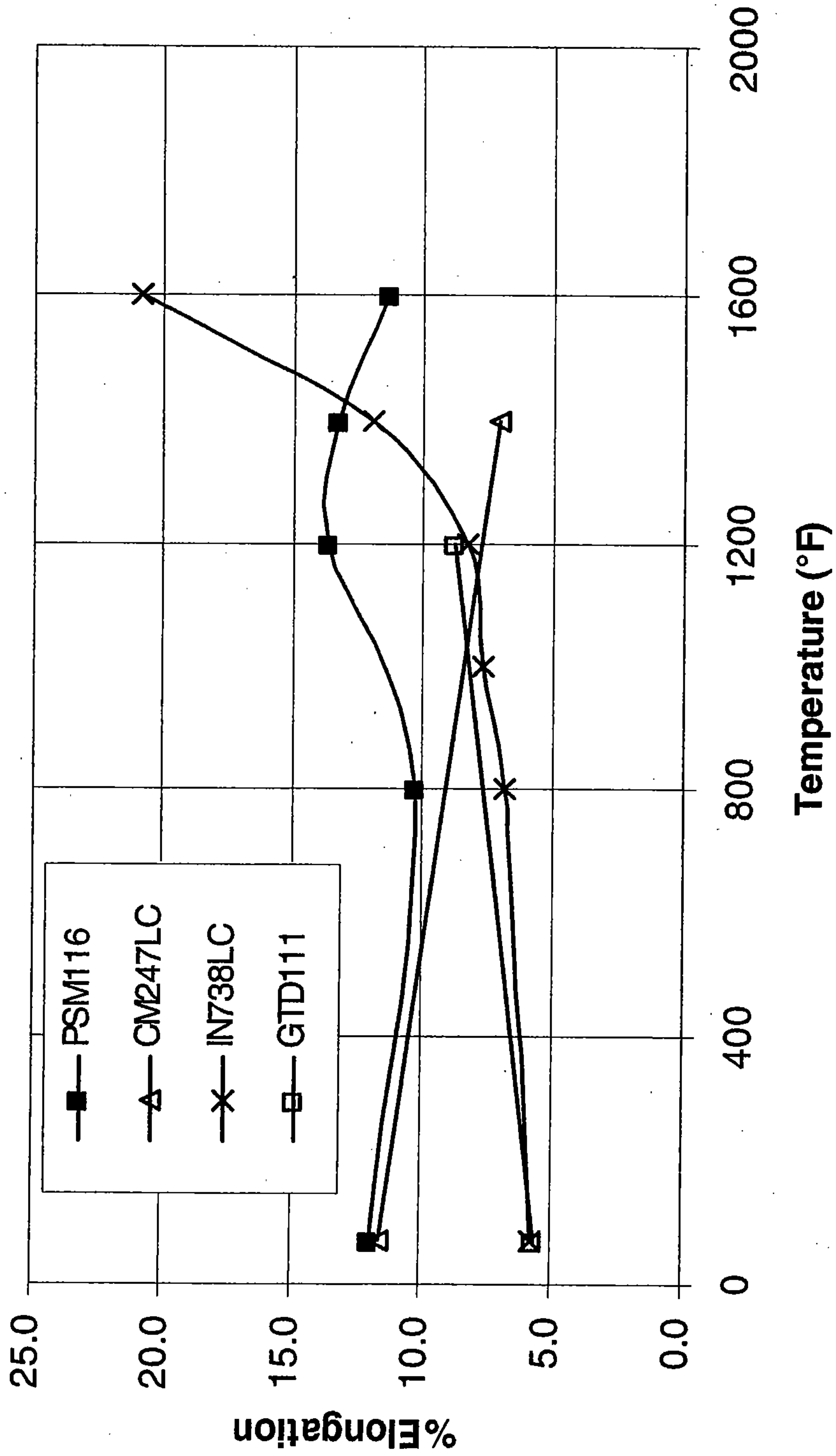

FIG.11

Typical Blade Creep Rupture Life (Equiaxed)

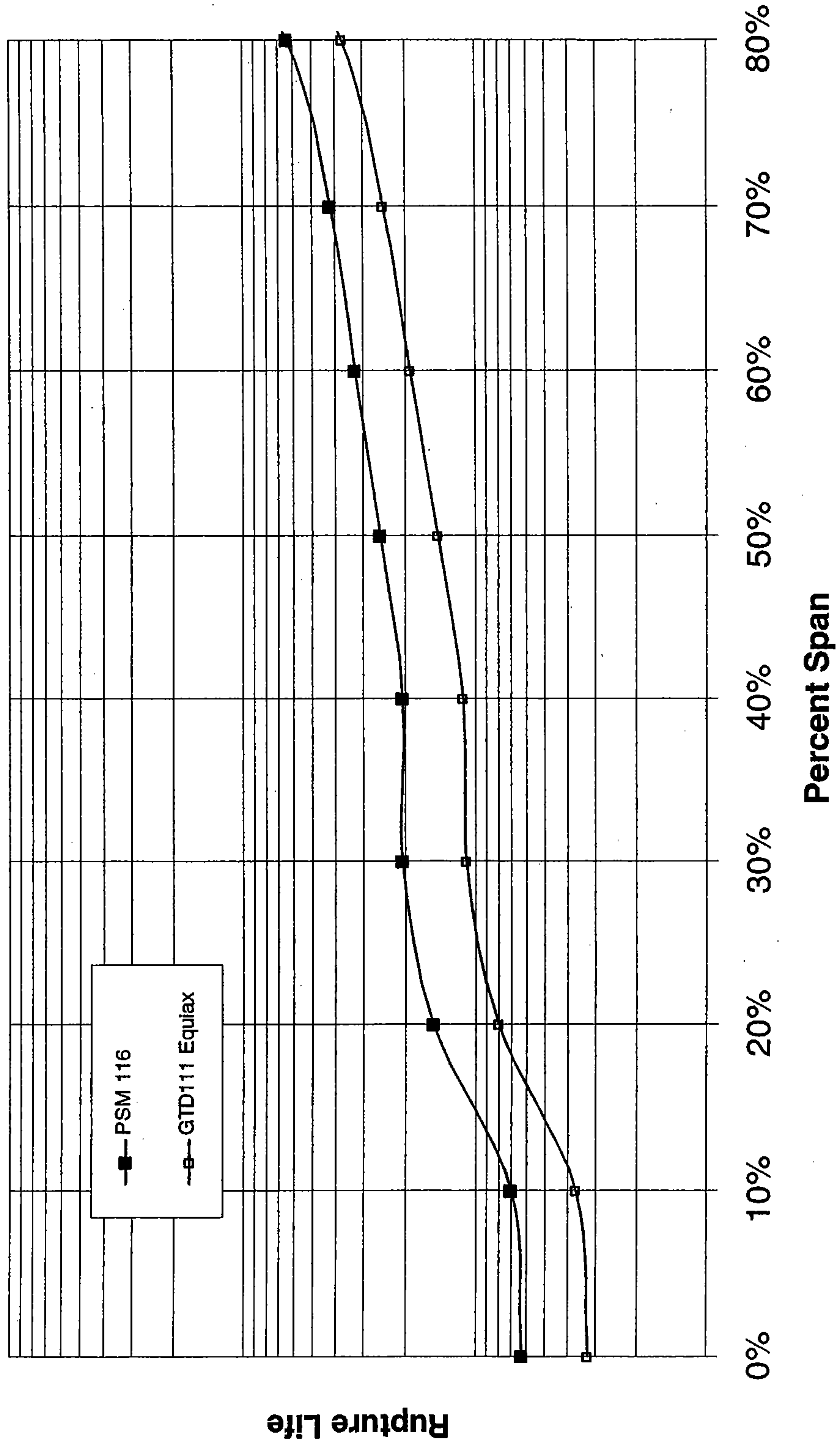

FIG.12

Typical Blade Creep Rupture Life (Equiaxed)

