



US 20080011636A1

(19) **United States**

(12) **Patent Application Publication**
St. John et al.

(10) **Pub. No.: US 2008/0011636 A1**

(43) **Pub. Date: Jan. 17, 2008**

(54) **PACKAGES FOR TOOTH WHITENING PRODUCTS**

(22) Filed: **Jun. 29, 2007**

Related U.S. Application Data

(75) Inventors: **Samuel James St. John,**
Cincinnati, OH (US); **Paul Albert**
Sagel, Mason, OH (US)

(60) Provisional application No. 60/831,356, filed on Jul. 17, 2006.

Publication Classification

Correspondence Address:
THE PROCTER & GAMBLE COMPANY
INTELLECTUAL PROPERTY DIVISION -
WEST BLDG.
WINTON HILL BUSINESS CENTER - BOX 412,
6250 CENTER HILL AVENUE
CINCINNATI, OH 45224

(51) **Int. Cl.**
A47K 5/00 (2006.01)

(52) **U.S. Cl.** **206/449**

(57) **ABSTRACT**

A packaged oral care product comprising a primary packaging material containing two or more oral care delivery systems. The primary package may be made from a material which is leak proof, and the primary package may be sized to contain two or more oral care delivery systems comprising peroxide. The primary package may be disposed within a secondary package.

(73) Assignee: **The Procter & Gamble**
Company, Cincinnati, OH (US)

(21) Appl. No.: **11/824,150**

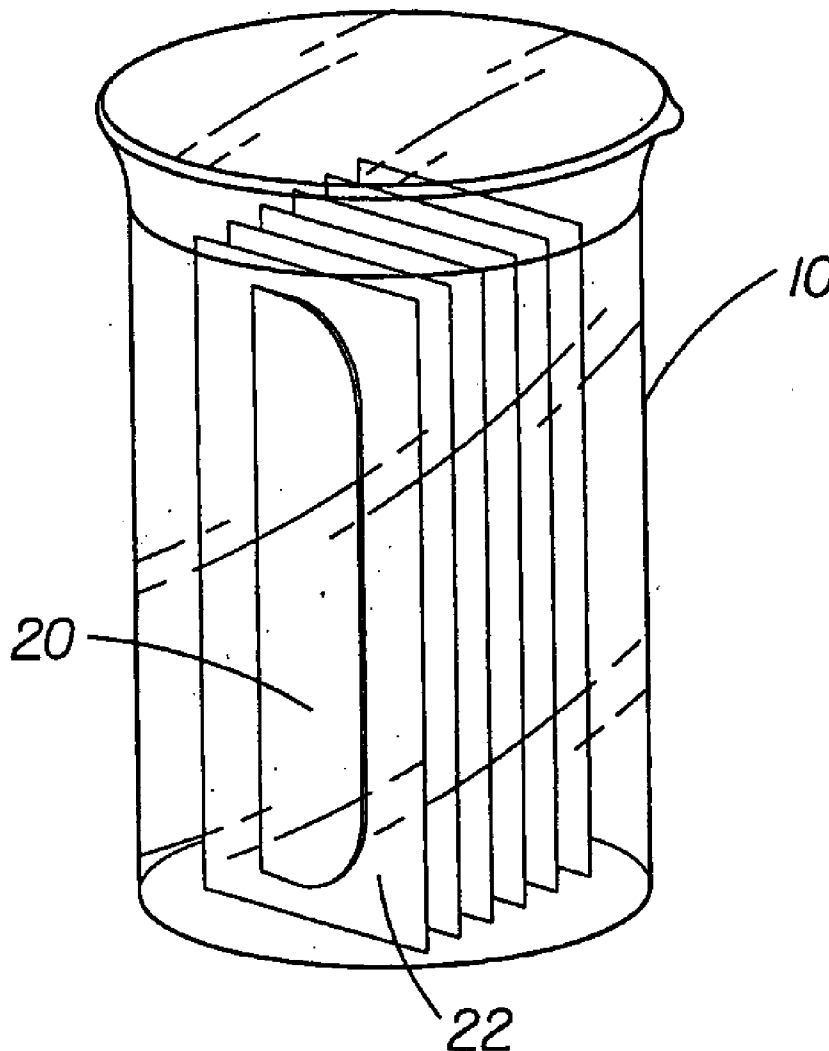

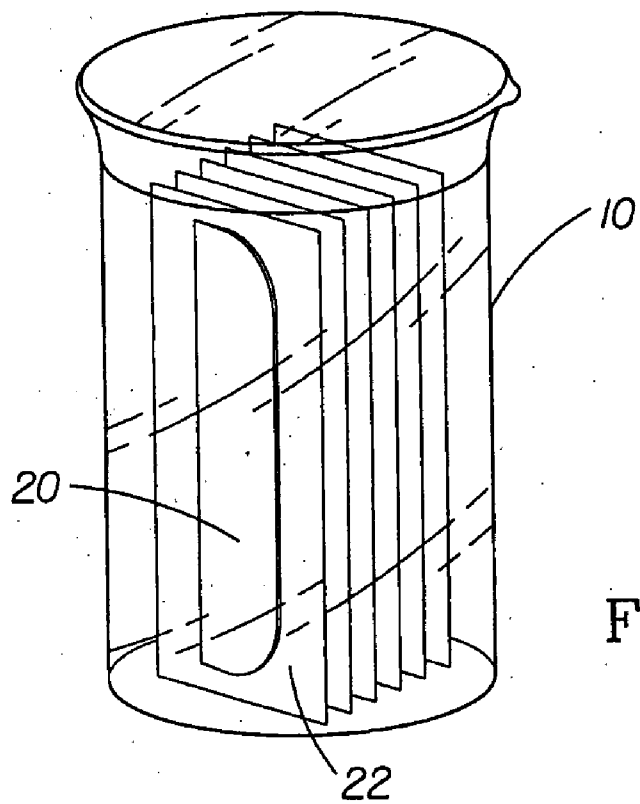

Fig. 1

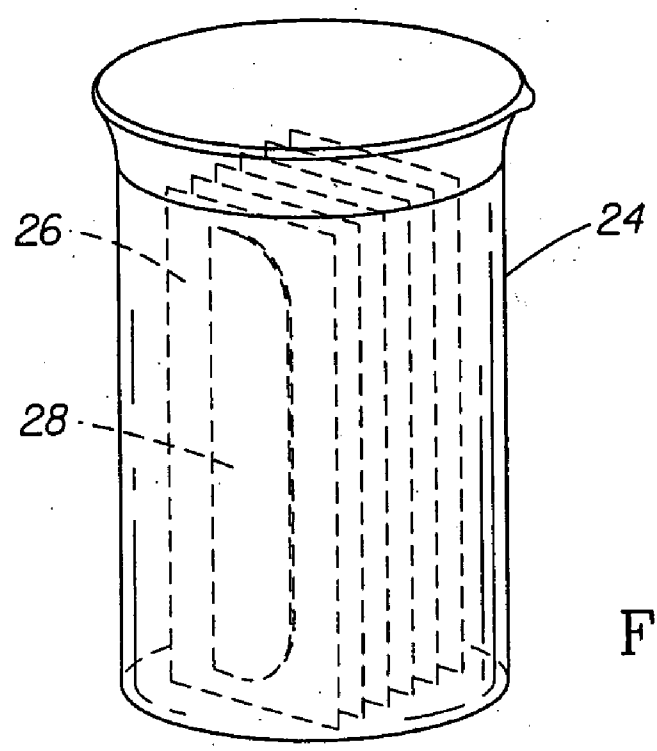

Fig. 2

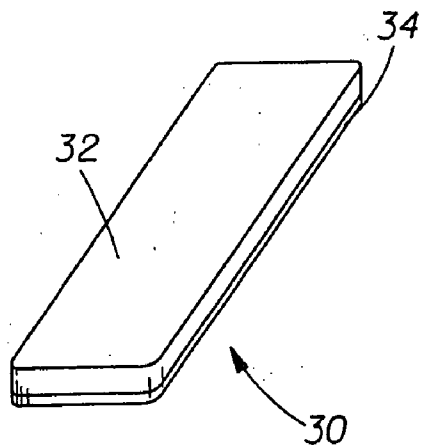

Fig. 3

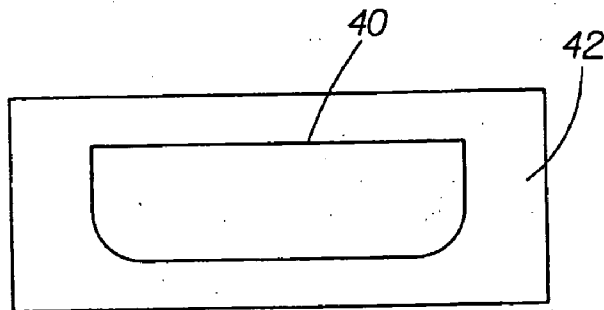

Fig. 4

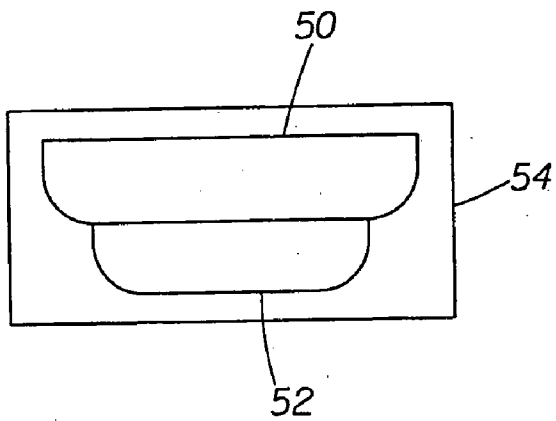

Fig. 5

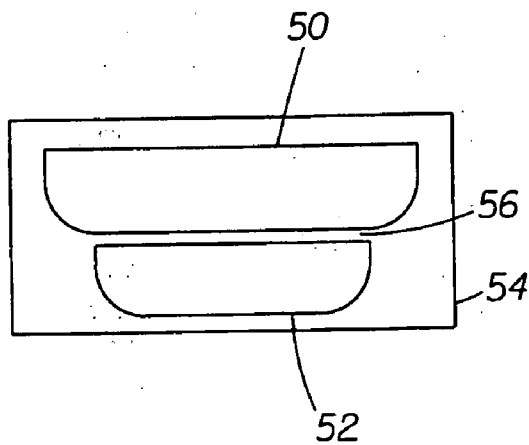

Fig. 6

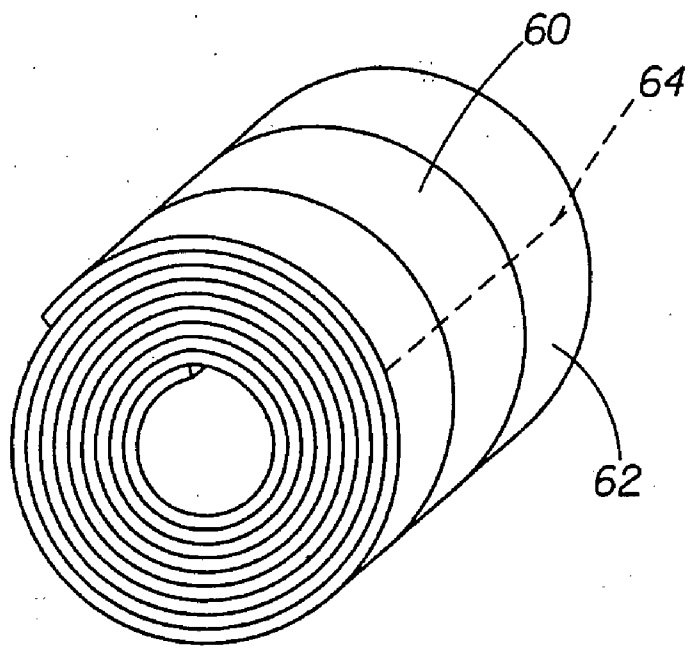

Fig. 7

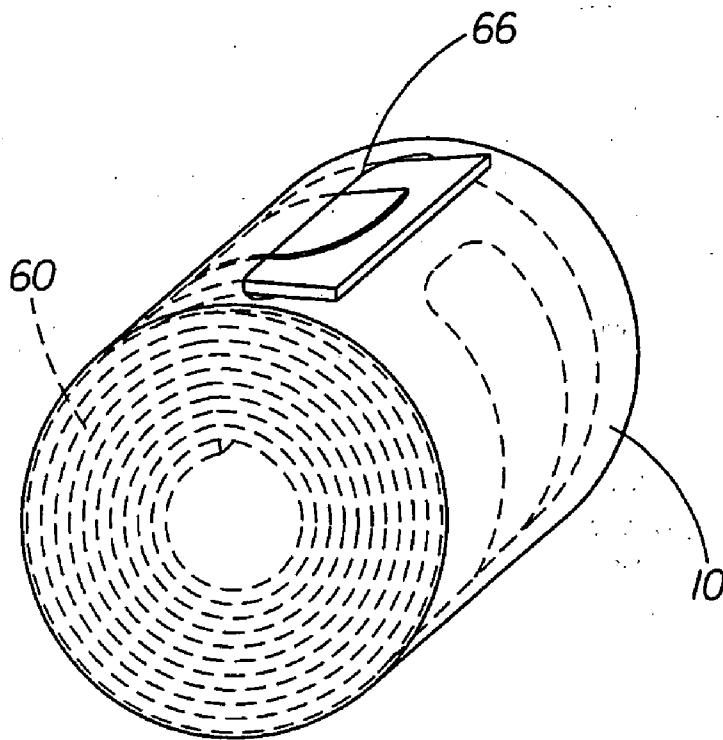

Fig. 8

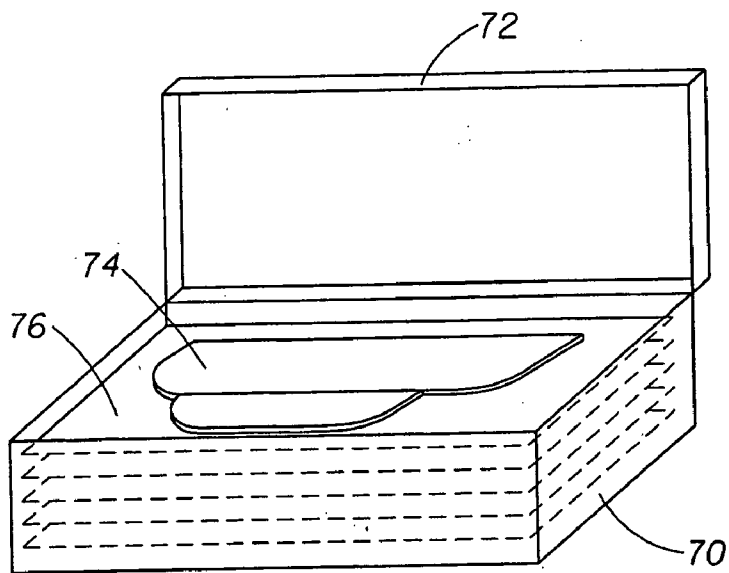

Fig. 9

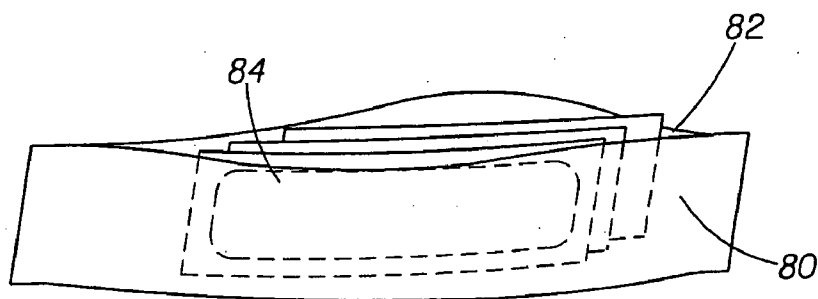

Fig. 10

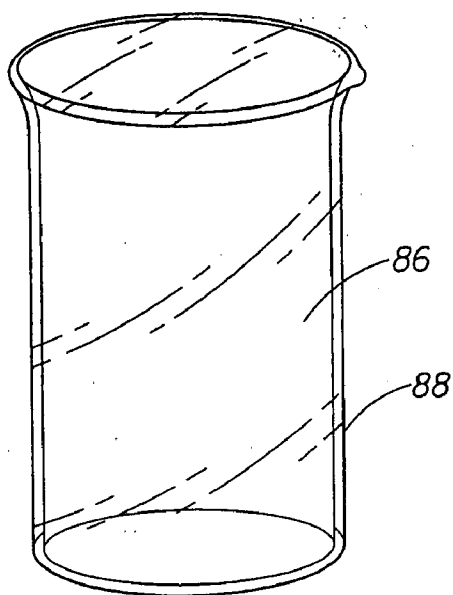
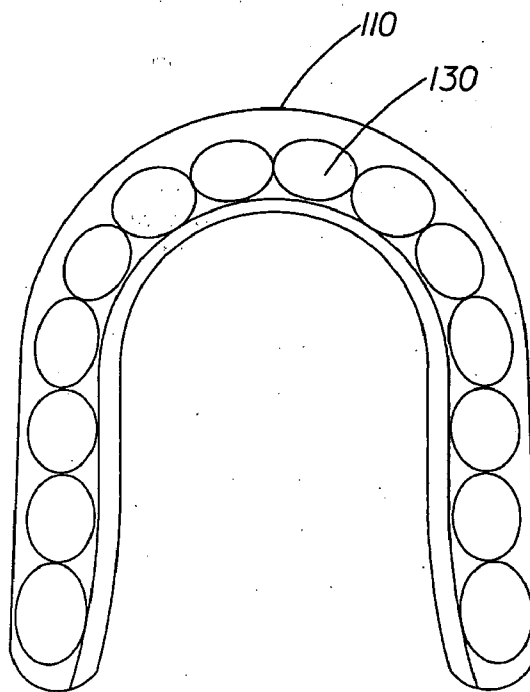
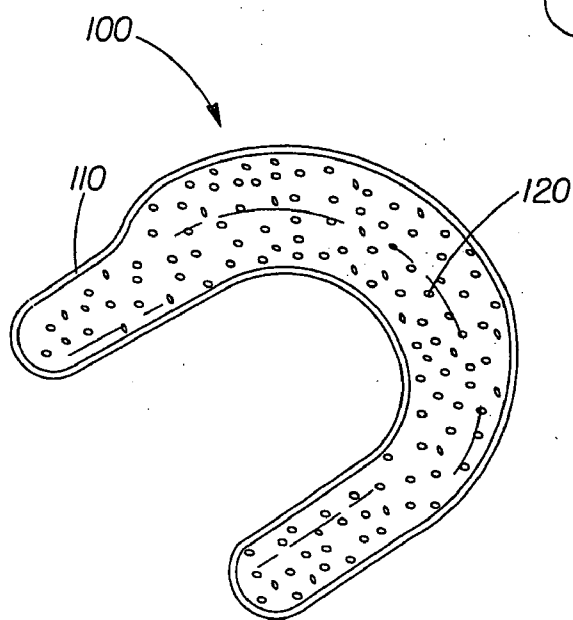
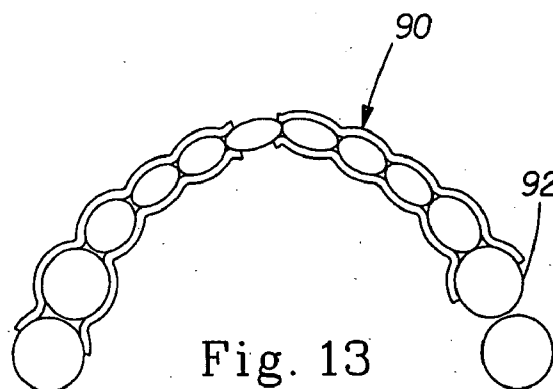
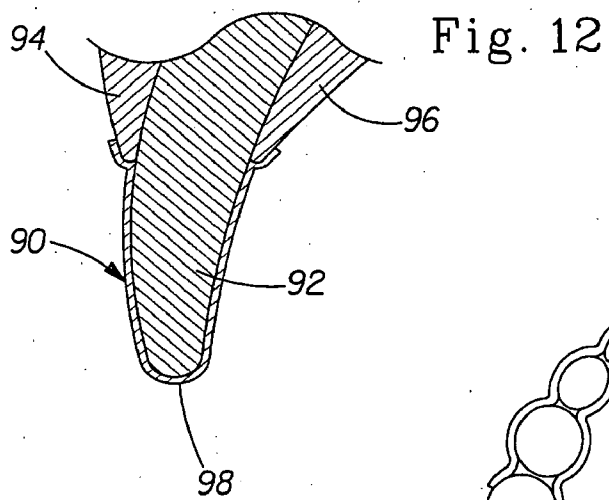

Fig. 11



PACKAGES FOR TOOTH WHITENING PRODUCTS

CROSS REFERENCE TO RELATED APPLICATION

[0001] This application claims the benefit of U.S. Provisional Application Ser. No. 60/831,356, filed Jul. 17, 2006.

FIELD OF THE INVENTION

[0002] This application relates to packaging and use of tooth whitening products.

BACKGROUND OF THE INVENTION

[0003] Tooth whitening has become popular in today's culture. More and more consumers are searching for the best method to achieve tooth whitening. However, there are now a variety of non-professional programs available to persons interested in whitening their teeth using commercial products available at drug stores. Commercial products include strip and tray type products, which often include a barrier material which is either pre-coated with a tooth whitening product or coated with a tooth whitening product prior to use. Traditionally these products are packaged individually, with a single application of the product contained within a sealed package. Prior to applying these tooth whitening products, a consumer opens a sealed package, remove the product from the packaging material and then applies the product to the teeth. In some products each individual strip or tray is sealed within a package, and then a number of these individually packaged products are sealed and/or contained within an additional package. Often times the first layer of package material is used to prevent evaporation of and/or changes to the oral care substance. Less stable actives (including peroxides) are often incorporated into these tooth whitening products; incorporation of less stable actives can greatly decrease the shelf life of the product. Additionally, it is beneficial to maintain many of the actives within a narrow concentration window to be safe and most effective within the oral cavity.

[0004] While different packaging materials have been used to slow the loss of peroxide concentration in tooth whitening products, there is a desire to improve stability and to maintain specific concentrations of the peroxide as well as other actives within the oral care product in order to ensure safety and efficacy and to extend shelf life of the product. Additionally, there is a desire to provide the stability benefit while minimizing packaging material. Packages of the present invention can be used to stabilize peroxide concentration as well as other actives and increase the shelf life of these products.

[0005] Packages of the present invention can be used to stabilize peroxide concentration and other actives and increase the shelf life of the oral care products also while minimizing packaging materials by bulk packaging of the oral care products. Bulk packaging allows the consumer to open one package, and remove and use as many of the oral care products as desired, thereby reducing the amount of

packaging materials and increasing consumer convenience while maintaining the desired level of oral care active(s) in the oral care products.

SUMMARY OF THE INVENTION

[0006] A package for an oral product comprising two or more oral care delivery systems contained within a primary package, wherein the oral care delivery systems comprise an oral care composition comprising peroxide and a barrier layer. Additionally, the oral care substance per square cm of the barrier layer to inner surface area of the primary package is about 0.000005 g/cm² to about 0.02 g/cm².

[0007] A package for an oral care product comprising a primary package comprising a body, wherein the body comprises a plurality of oral care delivery systems; and a lid which provides a seal for the primary package, wherein less than 100 grams per day of water is lost through the seal.

BRIEF DESCRIPTION OF THE DRAWINGS

[0008] While the specification concludes with claims which particularly point out and distinctly claim the present invention, it is believed that the present invention will be better understood from the following description of preferred embodiments, taken in conjunction with the accompanying drawings, in which like reference numerals identify identical elements and wherein:

[0009] FIG. 1 is a perspective view showing a transparent tube of the present invention containing oral care delivery systems;

[0010] FIG. 2 is a perspective view showing an opaque tube of the present invention containing oral care delivery systems;

[0011] FIG. 3 is a perspective view showing an oral care substance coated on a strip of material to form an oral care delivery system of the present invention;

[0012] FIG. 4 is a perspective view showing an oral care delivery system deposited on a release liner;

[0013] FIG. 5 is a perspective view showing two oral care delivery systems deposited on a single release liner;

[0014] FIG. 6 is a perspective view showing two oral care delivery systems deposited on a single release liner;

[0015] FIG. 7 is a perspective view showing multiple oral care delivery systems formed into a single roll;

[0016] FIG. 8 is a perspective view showing multiple oral care delivery systems formed into a single roll and contained within a tube, and having an opening from which the oral care delivery system can be dispensed;

[0017] FIG. 9 is a perspective view showing multiple oral care delivery systems contained within a box;

[0018] FIG. 10 is a perspective view showing multiple oral care delivery systems contained within a pouch;

[0019] FIG. 11 is a perspective view showing a tube contained within a polymer film secondary package;

[0020] FIG. 12 is a cross-sectional view showing a strip of the present invention conforming to the labial and lingual surfaces of the teeth and adjoining soft tissue;

[0021] FIG. 13 is a cross-sectional elevation view showing the strip of material of the present invention conforming to the labial and lingual surfaces of a plurality of adjacent teeth and adjoining soft tissue;

[0022] FIG. 14 is a perspective view of an oral care delivery system comprising a tray and an oral care composition; and

[0023] FIG. 15 is a perspective view showing the tray of the present invention conforming to the labial and lingual surfaces of a plurality of adjacent teeth and adjoining soft tissue.

DETAILED DESCRIPTION OF THE INVENTION

[0024] Generally, oral care substances comprising peroxide in a composition may be used for whitening the teeth as well as delivering additional oral care benefits. These oral care substances can be formed into an oral care delivery system if the substance can be shaped to fit manual application to the teeth, or the oral care delivery system can be formed by applying, for example coating, the substances onto a barrier material including, but not limited to a strip and/or a tray prior to manual application of the oral care delivery system to the teeth. The oral care delivery system can take a variety of forms, including but not limited to: individually sized strips shaped to fit over a plurality of teeth; a roll of barrier layer comprising an oral care substance which the user can sever to the desired length; and/or individual trays pre-filled with a oral care substance. These substances may all be contained within a primary package. The primary package can comprise two or more oral care delivery systems. The primary package may be contained within a secondary package.

Definitions

[0025] The abbreviation "cm", as used herein, means centimeter. The abbreviation "mm" as used herein, means millimeter. The abbreviation "g" as used herein, means gram.

[0026] By "safe and effective amount", as used herein, is meant an amount of an active at high enough levels to significantly improve the condition to be treated, but low enough to avoid serious side effects (at a reasonable benefit/risk ratio), within the scope of sound medical/dental judgment. The safe and effective amount of an active may vary with the particular condition being treated, the age and physical condition of the patient being treated, the severity of the condition, the duration of treatment, the nature of concurrent therapy, the specific form of the source employed, and the particular vehicle from which the active is applied.

[0027] As used herein the term "oral care delivery system" is intended to refer to an article comprising an oral care substance which can be manually applied to the surfaces of the teeth. In some embodiments the oral care delivery system comprises a barrier layer, to which the oral care substance is applied, for delivering the oral care substance to the surfaces of one or more teeth. The barrier layer includes, but is not limited to, a strip of material and/or a tray. In some embodiments the oral care substance is self supporting and can be a size and shape such that the oral care substance can be manually applied to the surfaces of the teeth without the support of a barrier layer. Optionally, the oral care delivery system can be deposited on a release liner.

[0028] As used herein, the phrase "oral care substance" is intended to refer to a substance which comprises an oral care active that is suitable for tooth whitening including, but not limited to, peroxides, perborates, percarbonates, peroxyacids, and/or any combination thereof; and the oral care substance may further comprise an additional oral care

active which delivers oral care benefits including, but not limited to, plaque removal, tartar removal, cavity prevention and treatment, inflamed and/or bleeding gums, mucosal wounds, lesions, ulcers, aphthous ulcers, cold sores and tooth abscesses, oral malodor, dental erosion, gingivitis, and/or periodontal disease.

[0029] By "oral condition" as used herein is meant diseases or conditions of the oral cavity including caries, plaque, breath malodor, dental erosion, gingivitis, and periodontal disease. Oral conditions are further described in WO 02/02096A2, published Jan. 10, 2002, P&G.

[0030] As used herein, the phrase "oral care active" is intended to refer to any material that is safe for use in the oral cavity that provides changes to the overall health of the oral cavity, and specifically the condition of the oral surfaces the oral care substance contacts.

[0031] As used herein, the phrase "tooth whitening active" is intended to refer to any active suitable for whitening the teeth, including, but not limited to, peroxides, metal chlorites, perborates, percarbonates, peroxyacids, and/or any combination thereof.

[0032] As used herein, the term "peroxide" (and its derivatives) is intended to refer to compounds that generate hydrogen peroxide when contacted with an aqueous media. Examples of a peroxide include, but are not limited to, hydrogen peroxide, carbamide peroxide, sodium percarbonate, etc.

[0033] As used herein, the phrase "peroxide concentration" is intended to refer to the equivalent concentration of hydrogen peroxide created from any peroxide generating species, expressed as a weight percentage.

[0034] As used herein, the phrase "primary package" is intended to refer to the first packaging materials which enclose and are in contact with the oral care delivery system(s).

[0035] As used herein, the phrase "secondary packaging" is intended to refer to any additional materials enclosing the oral care delivery system(s) which is enclosed within a primary package.

[0036] As used herein, the term "resealable" means that the container can be opened/reopened and closed/reclosed.

[0037] As used herein the terms "holds liquid water" and "leak proof" are intended to refer to packaging which passes the blue crystal dye test. The blue crystal dye test is a visual test to detect leaks within a package seal. A package seal passes the blue crystal dye test if the sheet of white paper, on which the package is placed, does not undergo a visually detectable color change. For example, if the white paper does not turn blue from contact with the crystal dye liquid which was contained within the package then the package holds liquid water and is leak proof. The blue crystal dye test is performed by (1) preparing a blue crystal dye liquid solution combining one teaspoon of blue crystal dye powder and one gallon of alcohol and mixing the solution; (2) pouring the blue crystal dye solution into the package and sealing the package (3) at room temperature, placing and orienting the container on white paper such that the fluid contained within the package is most likely to flow out of the package were the seal to be improperly fit and (4) after 30 minutes visually inspecting the white paper to determine if the sheet of white paper has been contaminated with the blue crystal dye solution.

[0038] All percentages and ratios used hereinafter are by weight of total oral care substance, unless otherwise indicated.

[0039] All measurements referred to herein are made at 25° C. unless otherwise specified.

[0040] All percentages, ratios, and levels of ingredients referred to herein are based on the actual amount of the ingredient, and do not include solvents, fillers, or other materials with which the ingredient may be combined as a commercially available product, unless otherwise indicated.

Bulk Packaging

[0041] Oral care delivery systems comprising tooth whitening actives, in particular peroxide, can have stability problems which minimize the shelf life of the product. Often these stability problems are minimized by the packaging; traditionally individual packaging for each individual oral care delivery system comprising peroxide. However, in the present invention the oral care delivery systems which comprise tooth whitening actives, in particular peroxide, can be stabilized and the shelf life of the oral care delivery systems comprising peroxide can be increased by multiple means including, but not limited to: 1) providing an amount of an oral care substance comprising peroxide per square cm of barrier layer at a particular ratio with the inner surface area of the primary packaging which optimizes both the amount of peroxide available to react, and the space within the packaging in which the peroxide can react; 2) optimizing the exchange of water between the environment outside and within the package via a selectively permeable seal and/or 3) any combination thereof.

[0042] In one embodiment the peroxide concentration of the oral care delivery system is stabilized and the shelf life of the oral care delivery systems comprising peroxide is increased by providing an amount of an oral care substance per square cm of barrier layer to inner surface area of the primary packaging at a ratio of from about 0.000005 g/cm²/cm² to about 0.02 g/cm²/cm², in another embodiment in a ratio of from about 0.00001 g/cm²/cm² to about 0.004 g/cm²/cm² and in another embodiment at a ratio of from about 0.00004 g/cm²/cm² to about 0.0004 g/cm²/cm². The peroxide is stabilized at the aforementioned ratios by optimizing the level of peroxide available to react with space available for the peroxide to react within the package.

[0043] In another embodiment the peroxide concentration of the oral care delivery system can be stabilized and shelf life of the oral care delivery systems comprising peroxide can be increased with a primary package having a selectively permeable seal. The seal should allow the package to hold liquid water, in other words the primary package is leak proof. In one embodiment the seal has less than 100 g/day water loss, in another embodiment the seal has from about 0 to about 100 g/day water loss, in another embodiment the seal has from about 0 to about 10 g/day water loss, in another embodiment the seal has from about 0.01 to about 10 g/day water loss, in another embodiment the seal has from about 0 to about 0.2 g/day water loss, in another embodiment the seal has from about 0 to about 0.01 g/day water loss and/or any combination thereof. All water loss is measured at about 25° C., 1 atm external pressure and 60% external relative humidity.

[0044] Additionally, the peroxide concentration of the oral care delivery system can be stabilized by maintaining a package having an internal pressure of from about 0 to about

5 atm, in another embodiment from about 1-5, in another embodiment from about 1-4, and in yet another embodiment from about 1-2 and/or any combination thereof.

[0045] The primary packaging of the present invention can be made from any material that is suitable for use with a peroxide containing oral care delivery system and that can be formed into a package which is substantially leak proof. In one embodiment the primary package comprises polymers including, but not limited to, polyethylene, ethylvinylacetate, ethylvinyl alcohol, polyesters such as Mylar manufactured by DuPont, fluoroplastics such as Teflon manufactured by DuPont, and combinations thereof. Additionally, in one embodiment the primary package (or at least the surfaces in contact with the peroxide active) can be formed from a polyolefin, for example from polyethylene or polypropylene. In another embodiment the primary package, or at least the surfaces in contact with the peroxide active, comprise polyolefin blends, polyethylene blends, polypropylene blends, and/or combinations thereof. The primary packaging of the present invention can be in a variety of shapes including, but not limited to, a box, a tube, and/or a pouch or envelope. In one embodiment the primary package is re-sealable. The primary package can be re-sealable via a variety of means including, but not limited to, a lid, an interlocking closure, a pressure fit seal, an adhesive seal, and/or any combination thereof. In one embodiment the primary package is a tube comprising polyethylene which further has a lid with a pressure fit seal. When the lid is closed the primary package is substantially leak proof. In another embodiment the primary package is a pouch with a pressure fit seal, which is re-sealable once opened. The pouch, at least when the pressure fit seal is closed, is substantially leak proof. In another embodiment the primary package is a box with a lid. The lid comprises an adhesive seal. When the lid on the box is closed, the box is substantially leak proof.

[0046] The primary package can be any size which can contain two or more oral care delivery systems. Depending on the size, and number of oral care delivery systems the primary package can have a volume from about 0.1 cm³ to about 2500 cm³.

[0047] The primary package can be transparent, translucent and/or opaque.

[0048] The secondary package can be any material that can be formed into a package and which can contain a primary package. The secondary package can be any polymer or cellulose based material. The secondary package may be a tube, a box, an envelope, a pouch, and/or a material which is wrapped around the primary package. The primary packages can be contained within the secondary package. For example, a primary package in the form of a pouch can contain two or more oral care delivery systems. The pouch can be contained within a tube. The consumer can open the tube and open the pouch to retrieve the oral care delivery system. In another embodiment the consumer can open a pouch contained within a tube, and remove the oral care delivery systems from the pouch, place them into the tube; thus, replacing the original primary package of a pouch with a primary package of a tube. The consumer now need only open the tube to retrieve the desired number of oral care delivery systems. In yet another embodiment a tube is the primary package and the tube is wrapped in a polymer film which is the secondary package.

[0049] Referring now to the drawings, and more particularly to FIG. 1, in one embodiment of the present invention the primary package can be a transparent tube 10. The tube 10 can comprise two or more oral care delivery systems 20. Optionally, the oral care delivery systems can be disposed on release liners 22 (oral care delivery systems are also shown in FIGS. 3-6). As shown in FIG. 2, in one embodiment of the present invention the primary package can be an opaque tube 24. The tube 24 can comprise two or more oral care delivery systems 28. Optionally, the oral care delivery systems can be disposed on release liners 26 (oral care delivery systems are also shown in FIGS. 3-6). In one embodiment (as shown in FIG. 3) the oral care delivery system 30 comprises an oral care substance 32 disposed on a backing layer 34. In another embodiment as shown in FIG. 4 the oral care delivery system 40 is disposed on a release liner 42. In yet another embodiment as shown in FIGS. 5-6 two oral care delivery systems, one for the upper dentition 50 and one for the lower dentition 52 are disposed on one release liner 54. The two oral care delivery systems can be disposed adjacent (as shown in FIG. 5) each other, or with a space 56 in between the two oral care delivery systems 50 and 52 (as shown in FIG. 6). In another embodiment the oral care delivery system is in the form of a roll (as shown in FIG. 7). The oral care composition disposed on a barrier layer is rolled up to form the oral care delivery system 60. The oral care delivery system 60 can be disposed on a release liner 62, which can also be in the form of a roll. The roll of oral care delivery systems 60 can be severed into the desired length for the user's teeth. Additionally, the roll of oral care delivery system may have cuts or serrations 64 indicating to the user where the product can be severed.

[0050] In one embodiment the tube 10 comprises from about 2 to about 200 oral care delivery systems, in another embodiment the tube comprises from about 2 to about 100 oral care delivery systems, in another embodiment the tube comprises from about 2 to about 50 oral care delivery systems, in another embodiment the tube comprises from about 10 to about 50 oral care delivery systems, in another embodiment the tube comprises greater than about 2, 5, 10, 20, 30, 40, 50, 60, 70, 80, 90, 100 and less than about 400, 300, 250, 200, 150, 100, 90, 80, 75, 60, 50, 44, 40, 35, 30 oral care delivery systems and any combination thereof. In another embodiment the tube 10 comprises the oral care delivery system 60 in the form of a roll (as shown in FIG. 8). The tube 10 can have an opening 66 through which the roll of oral care delivery system is removed. This opening 66 can be resealable. The tube 10 can comprise polyolefin and in another embodiment the tube 10 can comprise polyethylene or polypropylene. Additionally, in other embodiments the tube 10 comprises polyolefin blends, polyethylene blends, polypropylene blends, and combinations thereof.

[0051] In another embodiment the primary package is a box 70 (as shown in FIG. 9). The box can comprise a lid 72 which is resealable. Two or more oral care delivery systems 74 can be disposed within the box 70. The delivery systems 74 can be disposed on release liners 76.

[0052] In yet another embodiment the primary package is a pouch 80 (as shown in FIG. 10). The pouch 80 can comprise a resealable opening 82. Two or more oral care delivery systems 84 can be disposed within the pouch 80.

[0053] In another embodiment as shown in FIG. 11 the primary package is a tube 86 and the secondary package is a polymer film 88 sealed around the tube 86.

Barrier Layer

[0054] The barrier layer of the present invention can be any water impermeable layer to which an oral care substance can be applied including but not limited to, a strip of material and/or a tray.

[0055] The barrier layer serves as a protective barrier for the oral care substance. It can prevent substantial leaching and/or erosion of the oral care substance by for example, the wearer's lips, tongue, as well as saliva. This allows the oral care active to act upon their oral surfaces for an extended period of time, from several minutes to several hours. In one embodiment the barrier layer is a strip of material.

[0056] The strip of material may comprise any material, including one or more polymers, wax, foam, natural and synthetic woven materials, non-woven material, foil, paper, rubber, and combinations thereof. The strip of material can be provided as a polymeric film. The strip of material may be a single layer of material or a laminate comprising more than one layer. For example, the strip of material may comprise a laminate of two or more polymeric films or may comprise a wax and non-woven material, such as a polymeric scrim or mesh as described in USPN 2004/0005277. The strip of material may be substantially water impermeable. Some polymers suitable for use in manufacturing the strip of material include, but are not limited to, polyethylene, ethylvinylacetate, polyesters, ethylvinyl alcohol and combinations thereof. Examples of polyesters include Mylar® and fluoroplastics such as Teflon®, both manufactured by DuPont. The strip of material may have a thickness less than about 1 mm, or less than about 0.05 mm, or between about 0.001 and about 0.03 mm.

[0057] The strip of material 90 may have any shape and size that covers the facial and/or lingual surfaces of a plurality of teeth 92 and/or some of the soft tissue adjacent the facial 94 and/or the soft tissue adjacent the lingual surfaces 96 of a plurality of teeth 92 (as shown in FIGS. 12-13). In one embodiment, the length of the strip of material is from about 2 cm to about 12 cm and preferably from about 4 cm to about 9 cm. The width of the strip of material will also depend upon the oral surface area to be covered. In one example, the width of the strip of material is from about 0.5 cm to about 4 cm and preferably from about 1 cm to about 2 cm. As seen in FIG. 12, the strip of material may be folded about or is otherwise disposed about the incisal edges 98 of the plurality of teeth 92. The overall thickness of the product 10 may be less than about 2 mm, or less than about 1 mm, or less than about 0.5 mm prior to use and/or during use.

[0058] The flexural stiffness of the strip of material may be measured by using a strain gauge affixed to the end of a horizontal beam. The opposite end of the beam presses across a strip of the sample to force a portion of the strip into a vertical groove in a horizontal platform upon which the sample rests. A microammeter, wired to the strain gauge is calibrated in grams of deflection force. The rigidity of the sample is read directly from the microammeter and expressed as grams per centimeter of sample strip width. In some embodiments, the strip of material may have a flexural stiffness of less than about 5 grams/cm as measured on a Handle-O-Meter, model #211-300, available from Thwing-

Albert Instrument Co. of Philadelphia, Pa., as per test method ASTM D2923-95. In other embodiments, the strip of material has a flexural stiffness less than about 3 grams/cm, or less than about 2 grams/cm, or between about 0.1 grams/cm and about 1 grams/cm.

[0059] A low flexural stiffness can allow the strip of material to conform to the contours of the oral surfaces of the wearer's mouth because there is little residual force within the strip of material to cause it to return to its shape just prior to its application to the oral surface. The strip of material's flexibility can enable it to contact soft tissue over an extended period of time without irritation, and the strip of material would not require significant pressure to conform it to the surfaces of the teeth and/or soft tissue.

[0060] The strip of material is held in place on the oral surface by adhesive attachment provided by one or more of the oral care substances, the barrier composition or any other composition or agent that is applied to, coated on, or intermixed with the strip of material. Alternatively, the strip of material can be held in place by mechanical pressure from deforming the strip of material about the facial and/or lingual surfaces of the teeth. For example, where the strip of material undergoes permanent deformation during application to the teeth, the strip of material may be held in place by the pressure or fit of the strip of material about the teeth. In some embodiments, the strip of material may be dissolvable or erodible during use. Examples of strips of material that are dissolvable or erodible during use are described in U.S. Pat. Nos. 6,649,147; 2003/0228264; and 2004/0062724. The strip of material may dissolve or erode in less than about 1 hour, less than about 30 minutes, or less than about 15 minutes. After dissolution or erosion of the strip of material, the oral care substance may be left behind on the facial and/or lingual tooth surfaces and/or the soft tissues surfaces to can continue to act upon those surfaces.

[0061] In some embodiments having multiple oral care substances, it may be desirable for the oral care substances to then dissolve or erode at differing rates. For example, after dissolution of strip of material (or removal of the strip of material), an oral care substance comprising a tooth whitening active may rapidly dissolve while the oral care substance comprising an antibacterial active dissolves more slowly to allow the oral care active to continue to act upon the soft tissue or to deliver an agent to the oral cavity for a longer period of time. Examples of an oral care substance that could quickly dissolve upon removal, dissolution, or erosion of the strip are disclosed U.S. Pat. Nos. 6,669,930 and 5,098,303. It may be desirable for the oral care substance to remain on the oral tissue for up to 2 days. In another embodiment, it may be desirable for the oral care substance to remain on the oral tissue for greater than about 30 minutes, 1, 2, 4, 6, 8, 10, 12, 14, 16, 18, or 20 hours and or less than 24, 20, 18, 16, 14, 12, 10, 8, 6, or 4 hours. Examples of oral care substances that could adhere to tissues of the oral cavity for extended periods of time are disclosed in USPNs 2005/0100515 and U.S. Pat No. 6,649,147.

[0062] Where the strip of material is non-dissolving or non-erodible, the strip of material and the one or more oral care substances may be cleanly removed from the tooth surfaces and soft tissue so that little or no residue of the oral care substance(s) are left behind upon removal. Alternatively, removal of the strip of material may cleanly remove the one oral care substance, such as a tooth whitening oral care substance, and leave a second oral care substance on the

oral tissue so that the oral care active in the second oral care substance can continue to act upon the tissue over an extended period of time. In the later instance, the second oral care substance might have less adhesive affinity for the strip of material than the first oral care substance has for the strip of material so that the second oral care substance remains behind while the first oral care substance adheres to the strip of material and is removed therewith. The strip of material might have a release coating (e.g., Teflon, silicone, fluoropolymers, etc.) applied thereto over the portion of the strip of material that contacts the second oral care substance to facilitate or effectuate the release between the strip of material and the second oral care substance upon removal of the strip of material from the teeth.

[0063] The peel force required to remove the strip of material from the tooth surfaces and the soft tissue may be between about 1 gram and about 50 grams for a 1.5 cm strip width (approximately 17 grams/cm) is all that is required. In another embodiment, the peel force may be between about 10 grams and about 40 grams, or between about 20 grams and about 30 grams.

[0064] In another embodiment the barrier layer is a tray. As shown in FIGS. 14-15 the oral care delivery system 100 can comprise a tray 110 and an oral care substance 120. The tray 110 can be pre-filled with the oral care substance 120 prior to packaging or the oral care substance 120 can be placed into the tray 110 immediately prior to application to the teeth. The tray generally is applied to all the teeth 130 as shown in FIG. 15. Examples of trays include but are not limited to those trays disclosed in U.S. Pat. Nos. 6,730,316; 5,575,654; 5,863,202; 5,980,249; and RE 34,196.

Oral Care Substances

[0065] A safe and effective amount of the compositions of the present invention may be topically applied to the mucosal tissue of the oral cavity, to the gingival tissue of the oral cavity, and/or to the surface of the teeth, for the treatment or prevention of the above mentioned conditions of the oral cavity, in several ways. The amount of oral care substance applied to the strip of material or oral surface depends upon the size and capacity of the piece of material, concentration of the active, and the desired benefit sought. Generally, less than about 1 gram of oral substance is used. In one embodiment from about 0.05 grams to about 0.5 grams of the oral care substance is used. In another embodiment from about 0.1 to about 0.4 grams of the oral care substance is used. In yet another embodiment, the amount of oral care substance per square cm of material can be less than about 0.2 g/cm² and from about 0.005 g/cm² to about 0.1 g/cm², and in another embodiment from about 0.01 g/cm² to about 0.04 g/cm². The oral care substance can include an oral care active or agent that delivers one or more benefits to the soft tissue, or, in some instances to the hard tissue of the teeth. Benefits can include tooth whitening and/or bleaching, anti-microbial or bacteriocidal, anti-tartar, anti-caries, anti-sensitivity, malodor protection, etc.

[0066] The oral care substance can include one or more gelling agents, which may also act as an adhesive agent to adhere the oral care substance to the plurality of teeth. The concentration of the gelling agent may be greater than about 2, 4, 6, 8, 10, 15, 20, 30, 40, 50, 60 or less than about 80, 70, 60, 50, 40, 30, or 20 percent by weight of the tooth whitening oral care substance.

[0067] Suitable gelling agents, adhesion agents, and/or oral care substances useful in the present invention are described in U.S. Pat. Nos. 6,649,147; 6,780,401; 2004/0102554; 2005/0089819; 2003/0152528; 6,419,906; and 2005/0100515. Some of the gelling agents or adhesion agents may include silicone, polyethylene oxide, polyvinyl alcohol, poly alkyl vinyl ether-maleic acid copolymer (PVM/MA copolymer) such as, Gantrez AN 119, AN 139, and S-97, polyvinyl alcohol, polyacrylic acid, Poloxamer 407 (Pluronic), polyvinyl pyrrolidone-vinyl acetate copolymer (PVP/VA copolymer), such as Luviskol VA, and Plasdone S PVP/VA, polyvinyl pyrrolidone (PVP, e.g., K-15 to K-120), Polyquaterium-11 (Gafquat 755N), Polyquaterium-39 (Merquat plus 3330), carbomer or carboxypolymethylene (Carbopol), hydroxy propyl methyl cellulose, hydroxy ethyl cellulose, hydroxy propyl cellulose, carboxymethyl cellulose, gelatin and alginate salt such as sodium alginate, natural gums such as gum karaya, xanthan gum, Guar gum, gum arabic, gum tragacanth, and mixtures thereof.

[0068] A humectant or plasticizer may be included in the oral care substance, including glycerin, sorbitol, polyethylene glycol, propylene glycol, and other edible polyhydric alcohols. The humectants may be present between about 10% to about 95%, or between about 50% and about 80%, by weight of the oral care substance. An oral care substance can include flavoring agents, sweetening agents, opacifiers, and coloring agents.

[0069] Water may be included in the oral care substance. The concentration of water may be greater than about 0, 2, 5, 10, 15, 20, 25, 30, 35, 40, or 45% and/or less than about 80, 70, 60, 50, or 40% by weight of the oral care substance.

[0070] Oral care substances suitable for use in the present invention include those disclosed in U.S. Pat. Nos. 5,891,453; 5,879,691; 6,730,316; 6,277,458; 6,045,811; 5,989,569; 6,884,426; and U.S. patent application Ser. Nos. 10/715,003; 10/870,293 and 11/455,469.

[0071] 1. Tooth Whitening Actives

[0072] Generally, less than about 1 gram of an oral care substance comprising a tooth whitening active is applied to the strip of material. In one embodiment, between about 0.05 grams and about 0.5 grams, or between about 0.1 gram to about 0.4 grams of the oral care substance comprising a tooth whitening active is used. The amount of oral care substance comprising a tooth whitening active per square cm of material may be less than about 0.2 grams/cm², preferably from about 0.005 to about 0.1 grams/cm², and more preferably from about 0.01 grams/cm² to about 0.04 grams/cm².

[0073] The oral care substance comprising a tooth whitening active can be provided in a variety of forms, such as a solid, semi-solid or a liquid, including a viscous liquid, a paste, a gel, or a solution. In one embodiment the oral care substance comprising a tooth whitening active is in the form of a gel. The oral care substance comprising a tooth whitening active may have a viscosity between about 200 and about 5,000,000 cps at low shear rates (less than one 1/seconds). In one embodiment, the viscosity may be between about 100,000 and about 1,500,000 cps and in another embodiment between about 400,000 and about 1,000,000 cps.

[0074] A polymeric mesh or scrim may be incorporated in the oral care substance comprising a tooth whitening active.

[0075] The tooth whitening actives that may be suitable for use in the oral care substance include peroxides, metal chlorites, perborates, percarbonates, peroxyacids, and com-

binations thereof. Suitable peroxide compounds include hydrogen peroxide, calcium peroxide, carbamide peroxide, and mixtures thereof. Suitable metal chlorites include calcium chlorite, barium chlorite, magnesium chlorite, lithium chlorite, sodium chlorite, and potassium chlorite. Additional whitening actives may be hypochlorite and chlorine dioxide. The oral care substance may contain a tooth whitening active at greater than about 2, 4, 6, 8, or 10% and/or less than about 25, 20, 18, 16, 14, 12, or 10% by weight of the oral care substance.

[0076] 2. Anti-tartar Actives

[0077] Anti-tartar actives known for use in dental care products includes phosphates. Phosphates include pyrophosphates, polyphosphates, polyphosphonates and mixtures thereof. Pyrophosphates are among the best known for use in dental care products. Pyrophosphate ions are delivered to the teeth derive from pyrophosphate salts. The pyrophosphate salts useful in the present compositions include the dialkali metal pyrophosphate salts, tetra-alkali metal pyrophosphate salts, and mixtures thereof. Disodium dihydrogen pyrophosphate (Na₂H₂P₂O₇), tetrasodium pyrophosphate (Na₄P₂O₇), and tetrapotassium pyrophosphate (K₄P₂O₇) in their unhydrated as well as hydrated forms are the preferred species. While any of the above mentioned pyrophosphate salts may be used, tetrasodium pyrophosphate salt is preferred. In one embodiment the oral care composition comprises from about 0.5% to about 5% of a pyrophosphate by weight of the oral care composition. In another embodiment the oral care composition comprises from about 0.5% to about 3% of a pyrophosphate by weight of the oral care composition.

[0078] The pyrophosphate salts are described in more detail in Kirk & Othmer, *Encyclopedia of Chemical Technology*, Third Edition, Volume 17, Wiley-Interscience Publishers (1982), incorporated herein by reference in its entirety, including all references incorporated into Kirk & Othmer. Additional anticalculus actives include pyrophosphates or polyphosphates disclosed in U.S. Pat. No. 4,590,066; polyacrylates and other polycarboxylates such as those disclosed in U.S. Pat. Nos. 3,429,963 and 4,304,766; and U.S. Pat. No. 4,661,341; polyepoxysuccinates such as those disclosed in U.S. Pat. No. 4,846,650; ethylenediaminetetraacetic acid as disclosed in British Patent No. 490,384 dated Feb. 15, 1937; nitrilotriacetic acid and related compounds as disclosed in U.S. Pat. No. 3,678,154; polyphosphonates as disclosed in U.S. Pat. Nos. 3,737,533; 3,988,443 and 4,877,603. Anticalculus phosphates include potassium and sodium pyrophosphates; sodium tripolyphosphate; diphosphonates, such as ethane-1-hydroxy-1,1-diphosphonate, 1-azacycloheptane-1,1-diphosphonate, and linear alkyl diphosphonates; linear carboxylic acids; and sodium zinc citrate.

[0079] Actives that may be used in place of or in combination with the pyrophosphate salt include such known materials as synthetic anionic polymers including polyacrylates and copolymers of maleic anhydride or acid and methyl vinyl ether (e.g., Gantrez), as described, for example, in U.S. Pat. No. 4,627,977; as well as, e.g., polyamino propoane sulfonic acid (AMPS), zinc citrate trihydrate, polyphosphates (e.g., tripolyphosphate; hexametaphosphate), diphosphonates (e.g., EHDP; AHP), polypeptides (such as polyaspartic and polyglutamic acids), and mixtures thereof.

[0080] Other anti-tartar actives include sodium hexametaphosphate.

[0081] 3. Anti-Caries Actives

[0082] Fluoride ion sources are well known for use in oral care compositions as anticaries Actives. Fluoride ions are contained in a number of oral care compositions for this purpose, particularly toothpastes. Patents disclosing such toothpastes include U.S. Pat. Nos. 3,538,230; 3,689,637; 3,711,604; 3,911,104; 3,935,306; and 4,040,858.

[0083] Application of fluoride ions to dental enamel serves to protect teeth against decay. A wide variety of fluoride ion-yielding materials can be employed as sources of soluble fluoride in the instant compositions. Examples of suitable fluoride ion-yielding materials are found in U.S. Pat. Nos. 3,535,421 and 3,678,154. Preferred fluoride ion sources for use herein include stannous fluoride, monofluorophosphate, sodium fluoride, potassium fluoride and ammonium fluoride. Sodium fluoride is particularly preferred. Preferably the instant compositions provide from about 50 ppm to 10,000 ppm, more preferably from about 100 to 3000 ppm, of fluoride ions in the aqueous solutions that contact dental surfaces when used with the strip of material used in the mouth.

[0084] Other anti-caries actives include xylitol.

[0085] 4. Antimicrobial Actives

[0086] Antimicrobial actives can also be present in the oral care compositions. Such actives may include, but are not limited to, 5-chloro-2-(2,4-dichlorophenoxy)-phenol, commonly referred to as triclosan, and described in The Merck Index, 11th ed. (1989), pp. 1529 (entry no. 9573) in U.S. Pat. No. 3,506,720, and in European Patent Application No. 0,251,591 of Beecham Group, PLC, published Jan. 7, 1988; phthalic acid and its salts including, but not limited to those disclosed in U.S. Pat. No. 4,994,262, substituted monoperoxyphthalic acid and its salts and esters as disclosed in U.S. Pat. Nos. 4,990,329; 5,110,583; and 4,716,035; preferably magnesium monoperoxy phthalate, chlorhexidine (Merck Index, no. 2090), alexidine (Merck Index, no. 222; hexetidine (Merck Index, no. 4624); sanguinarine (Merck Index, no. 8320); benzalkonium chloride (Merck Index, no. 1066); salicylanilide (Merck Index, no. 8299); domiphen bromide (Merck Index, no. 3411); cetylpyridinium chloride (CPC) (Merck Index, no. 2024); tetradecylpyridinium chloride (TPC); N-tetradecyl-4-ethylpyridinium chloride (TDEPC); octenidine; delmopinol, octapinol, and other piperidino derivatives; nicin preparations; zinc/stannous ion actives; antibiotics such as augmentin, amoxicillin, tetracycline, doxycycline, minocycline, and metronidazole; and analogs and salts of the above; essential oils including thymol, geraniol, carvacrol, citral, hinokitiol, eucalyptol, catechol (particularly 4-allyl catechol), metals or metal ions (e.g., silver, copper, zinc, etc) and mixtures thereof; methyl salicylate; chlorite and metal salts of chlorite and mixtures of all of the above.

[0087] 5. Anti-inflammatory and Anti-sensitivity Actives

[0088] Anti-inflammatory actives can also be present in the oral care compositions. Such actives may include, but are not limited to, non-steroidal anti-inflammatory actives or NSAIDs such as ketorolac, flurbiprofen, ibuprofen, naproxen, indomethacin, aspirin, ketoprofen, piroxicam and meclofenamic acid. Use of NSAIDs such as Ketorolac are claimed in U.S. Pat. No. 5,626,838. Disclosed therein are methods of preventing and, or treating primary and reoccurring squamous cell carcinoma of the oral cavity or oropharynx by topical administration to the oral cavity or oropharynx an effective amount of an NSAID.

[0089] Anti-sensitivity actives can include potassium nitrate, clove oil (Eugenol) and other herbal or flavor actives/agents.

[0090] 6. Nutrients

[0091] Nutrients may improve the condition of the oral cavity and can be included in the oral care compositions. Nutrients include minerals, vitamins, oral nutritional supplements, enteral nutritional supplements, and mixtures thereof.

[0092] Minerals that can be included with the compositions of the present invention include calcium, phosphorus, fluoride, zinc, manganese, potassium and mixtures thereof. These minerals are disclosed in Drug Facts and Comparisons (loose leaf drug information service), Wolters Kluwer Company, St. Louis, Mo., ©1997, pp 10-17; incorporated herein by reference.

[0093] Vitamins can be included with minerals or used separately. Vitamins include Vitamins C and D, thiamine, riboflavin, calcium pantothenate, niacin, folic acid, nicotinamide, pyridoxine, cyanocobalamin, para-aminobenzoic acid, bioflavonoids, and mixtures thereof. Such vitamins are disclosed in Drug Facts and Comparisons (loose leaf drug information service), Wolters Kluwer Company, St. Louis, Mo., ©1997, pp. 3-10; incorporated herein by reference.

[0094] Oral nutritional supplements include amino acids, lipotropics, fish oil, and mixtures thereof, as disclosed in Drug Facts and Comparisons (loose leaf drug information service), Wolters Kluwer Company, St. Louis, Mo., ©1997, pp. 54-54e; incorporated herein by reference. Amino acids include, but, are not limited to L-Tryptophan, L-Lysine, Methionine, Threonine, Levocarnitine or L-carnitine and mixtures thereof. Lipotropics include, but, are not limited to choline, inositol, betaine, linoleic acid, linolenic acid, and mixtures thereof. Fish oil contains large amounts of Omega-3 (N-3) Polyunsaturated fatty acids, eicosapentaenoic acid and docosahexaenoic acid.

[0095] Enteral nutritional supplements include, but, are not limited to protein products, glucose polymers, corn oil, safflower oil, medium chain triglycerides as disclosed in Drug Facts and Comparisons (loose leaf drug information service), Wolters Kluwer Company, St. Louis, Mo., © 1997, pp. 55-57; incorporated herein by reference.

[0096] 7. Mouth and Throat Products

[0097] Other materials that can be used with the present invention include commonly known mouth and throat products. Such products are disclosed in Drug Facts and Comparisons (loose leaf drug information service), Wolters Kluwer Company, St. Louis, Mo., ©1997, pp. 520b-527; incorporated herein by reference. These products include, but, are not limited to anti-fungal, antibiotic and analgesic actives.

[0098] 8. Antioxidants

[0099] Antioxidants are generally recognized as useful in compositions such as those of the present invention. Antioxidants are disclosed in texts such as Cadenas and Packer, The Handbook of Antioxidants, ©1996 by Marcel Dekker, Inc., incorporated herein by reference. Antioxidants that may be included in the oral care composition or substance of the present invention include, but are not limited to Vitamin E, ascorbic acid, Uric acid, carotenoids, Vitamin A, flavonoids and polyphenols, herbal antioxidants, melatonin, aminoindoles, lipoic acids and mixtures thereof.

[0100] 9. Flavor and Aesthetic Agents

[0101] Flavor and aesthetic agents can be useful in compositions such as those of the present invention. Flavor and aesthetic agents suitable for use in the present invention

include, but are not limited to, those disclosed in U.S. Pat. Nos. 5,891,453, 5,879,691 and 6,916,463.

Methods of Use

[0102] A safe and effective amount of the compositions of the present invention may be topically applied to the mucosal tissue of the oral cavity, to the gingival tissue of the oral cavity, and/or to the surface of the teeth, for the treatment or prevention of the above mentioned conditions of the oral cavity, in several ways.

[0103] The product 10 and/or 20 can be applied to the teeth and/or soft tissue for between about 1 minute and about 8 hours. In some embodiments, it may be desirable to follow a regimen where the product is applied for greater than about 1, 2, 3, 4, 5, 6, 7, 8, 9, 10, 15, 20, 30, 40, 50, 60, 90, 120, 150, 180, 210, 240, 270, 300, 330, 360, 390, 420, 450, 480 and/or less than 480, 450, 420, 390, 360, 330, 300, 270, 240, 210, 180, 150, 120, 90, 60, 50, 40, 30, 20, 15, 10, 9, 8, 7, 6, 5, 4, 3, or 2 minutes and any combination thereof, wherein each of the oral care active(s) has a concentration between about 1% and about 50% by weight of the oral care substance. Such a regimen could be advantageously used once a day for greater than about one month, two months, four months, six months, twelve months, eighteen months, two years, five years, eight years, ten years and/or less than about fifteen years, ten years, eight years, five years, two years, 18 months, 12 months, six months, four months, two months, one month and any combination thereof. In another embodiment such a regimen could be advantageously used once a day for greater than about one month and less than about 5 years. A kit could be provided that contains a one month, two month, three month, four month, five month, six month, or 12 month supply of the product 10 and/or 20 for both the upper and lower dentition. The product 10 and/or 20 can be packaged, such as in a pouch, and, in turn, a plurality of the packaged products 10 and/or 20 can be provided in a storage container or outer package or carton, such as shown by way of example in U.S. Pat. No. D496,495. Such a regimen could also be employed for use in the shower either in the morning or evening, wherein the product is worn during showering or bathing. Each application of a product to the teeth may utilize a new or fresh product from the kit.

[0104] All documents cited in the Detailed Description of the Invention are, in relevant part, incorporated herein by reference; the citation of any document is not to be construed as an admission that it is prior art with respect to the present invention.

[0105] While particular embodiments of the present invention have been illustrated and described, it would be obvious to those skilled in the art that various other changes and modifications can be made without departing from the spirit and scope of the invention. It is therefore intended to cover in the appended claims all such changes and modifications that are within the scope of this invention.

What is claimed is:

- 1. A package for an oral product comprising: two or more oral care delivery systems contained within a primary package, wherein said oral care delivery systems comprise an oral care composition comprising peroxide and a barrier layer, and wherein said oral care substance per square cm of said barrier layer to inner surface area of said primary package is about 0.000005 g/cm²/cm² to about 0.02 g/cm²/cm².
- 2. The package of claim 1, wherein said barrier layer is a strip of material coated with said oral care substance.
- 3. The package of claim 1, wherein said primary package is contained within a secondary package.
- 4. The package of claim 3, wherein said secondary package is a polymer film.
- 5. The package of claim 1, wherein said primary package is a tube.
- 6. The package of claim 5, wherein said tube is opaque.
- 7. The package of claim 5, wherein said tube is transparent.
- 8. The package of claim 5, wherein said tube has a lid which seals the package closed.
- 9. The package of claim 8, wherein said seal has less than 100 grams per day water loss.
- 10. The package of claim 1, wherein said primary package is a box.
- 11. The package of claim 1, wherein said primary package is a pouch.
- 12. The package of claim 1, wherein said oral care delivery system comprises an oral care composition comprising flavor.
- 13. A package for an oral care product comprising:
 - (a) a primary package comprising a body, wherein said body comprises a plurality of oral care delivery systems; and
 - (b) a lid which provides a seal for the primary package, wherein less than 100 grams per day of water is lost through said seal.
- 14. The package of claim 13, wherein said seal has from about 0 to about 100 grams per day water loss.
- 15. The package of claim 14, wherein said seal has from about 0 to about 10 grams per day water loss.
- 16. The package of claim 15, wherein said seal has from about 0.01 to about 10 grams per day water loss.
- 17. The package of claim 15, wherein said seal has from about 0 to about 0.01 grams per day water loss.
- 18. The package of claim 13 wherein said primary package is a tube.
- 19. The package of claim 13 wherein said oral care delivery system comprises an oral care composition comprising peroxide.
- 20. The package of claim 19, wherein said primary package comprises from about 2 to about 100 oral care delivery systems.

* * * * *