



US 20030168455A1

(19) **United States**

(12) **Patent Application Publication**

Zettle et al.

(10) **Pub. No.: US 2003/0168455 A1**

(43) **Pub. Date: Sep. 11, 2003**

(54) **CONTAINER LID WITH SELECTABLE OPENING AND VALVE ASSEMBLY FOR RETAINING A VALVE**

(52) **U.S. Cl. 220/254.3; 220/714**

(76) **Inventors: Jeffrey J. Zettle, Bay City, MI (US); Gregory Ball, Girard, PA (US); Anthony Weber, Racine, WI (US); Craig R. Gosen, Sanford, MI (US)**

(57) **ABSTRACT**

Correspondence Address:
S.C. JOHNSON & SON, INC.
1525 HOWE STREET
RACINE, WI 53403-2236 (US)

A lid includes a flat portion having a first aperture and a second aperture formed therein, a hinge positioned about a center of the flat portion such that the first aperture is on one side of the hinge and the second aperture is on an opposite side of the hinge, a cover, having two directly opposing sidewalls each with a protrusion, rotatably attached to the flat portion via the hinge, a valve housing integrally formed with the flat portion, a valve, and a valve retainer for retaining the valve within the valve housing. The cover pivots relative to the flat portion so as to engage either the first aperture or the second aperture, and when the protrusion on one sidewall of the cover is pivoted towards the first aperture, the protrusion on the other sidewall simultaneously pivots away from the second aperture.

(21) **Appl. No.: 10/092,469**

(22) **Filed: Mar. 8, 2002**

Publication Classification

(51) **Int. Cl.⁷ A47G 19/22**

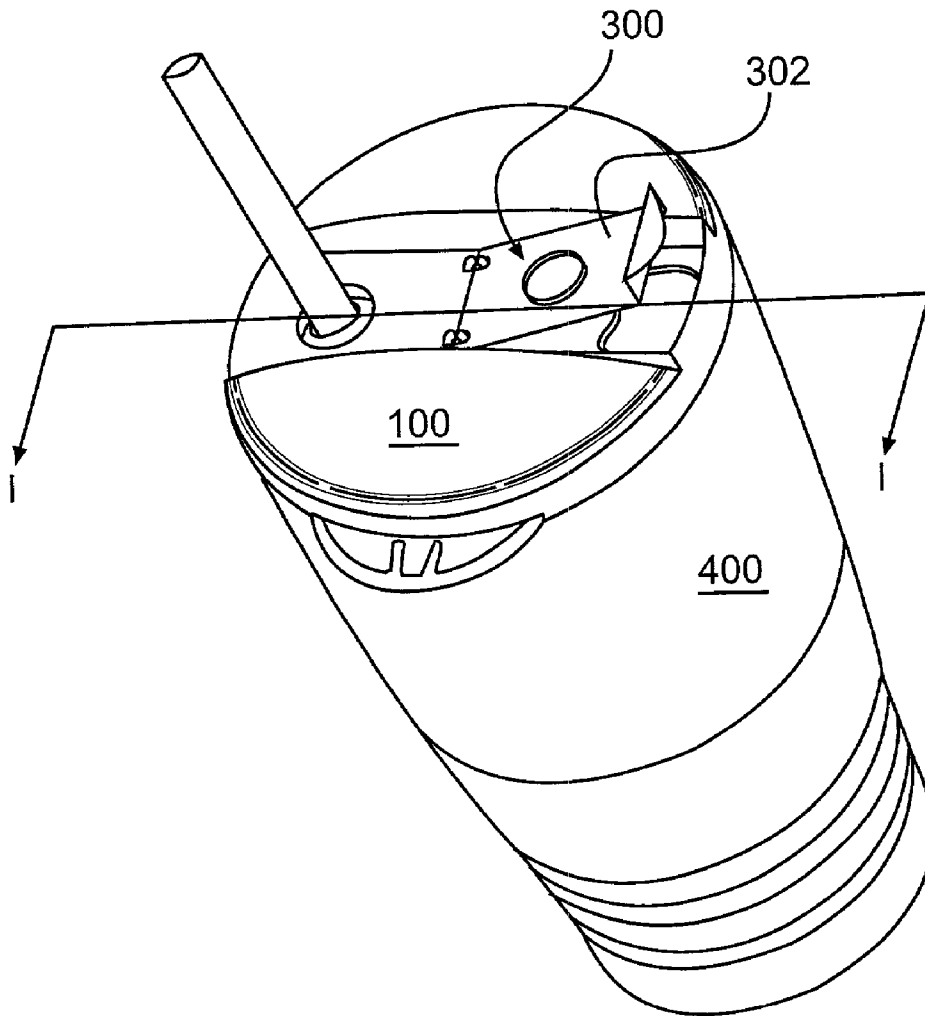

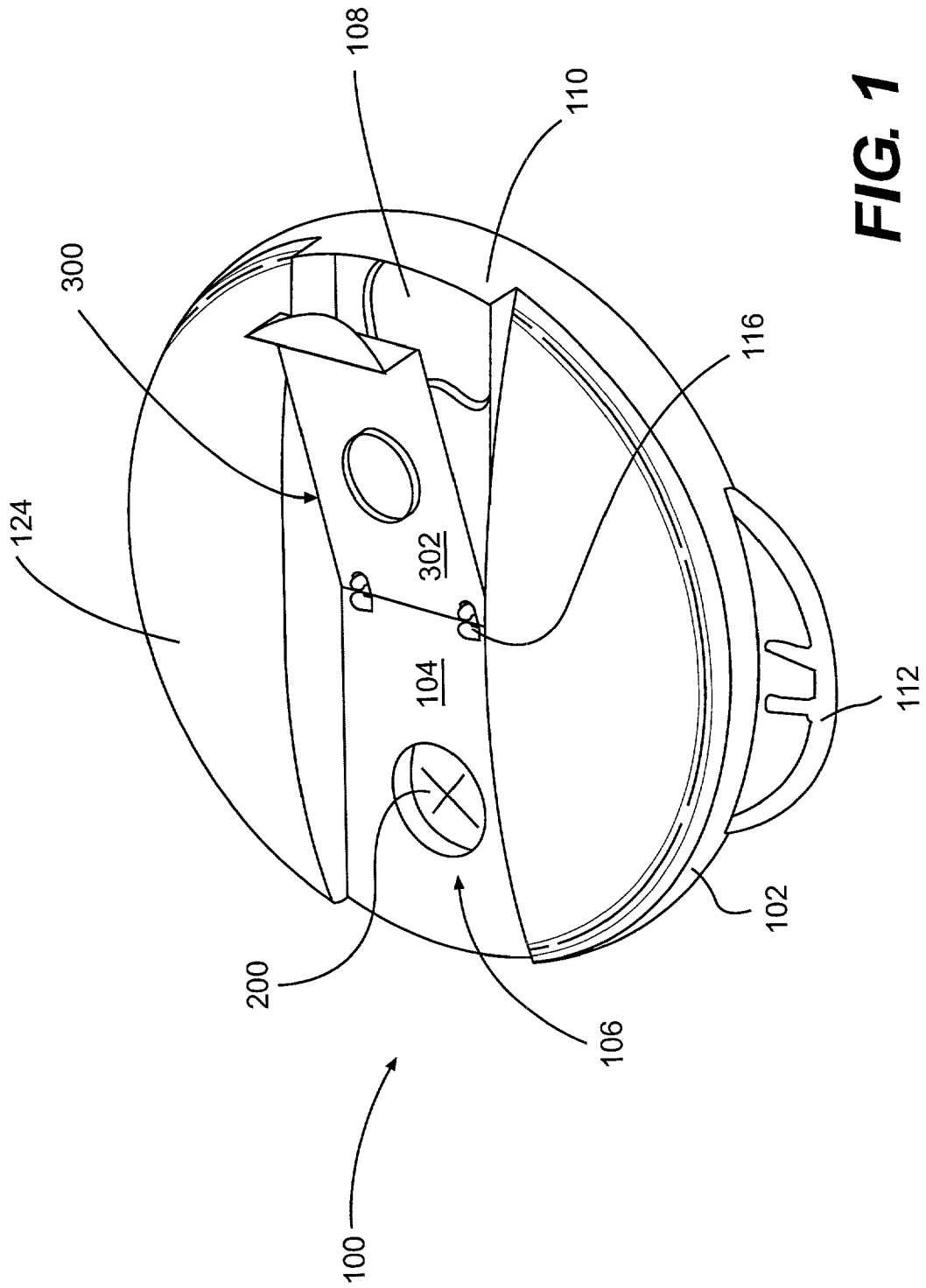

FIG. 1

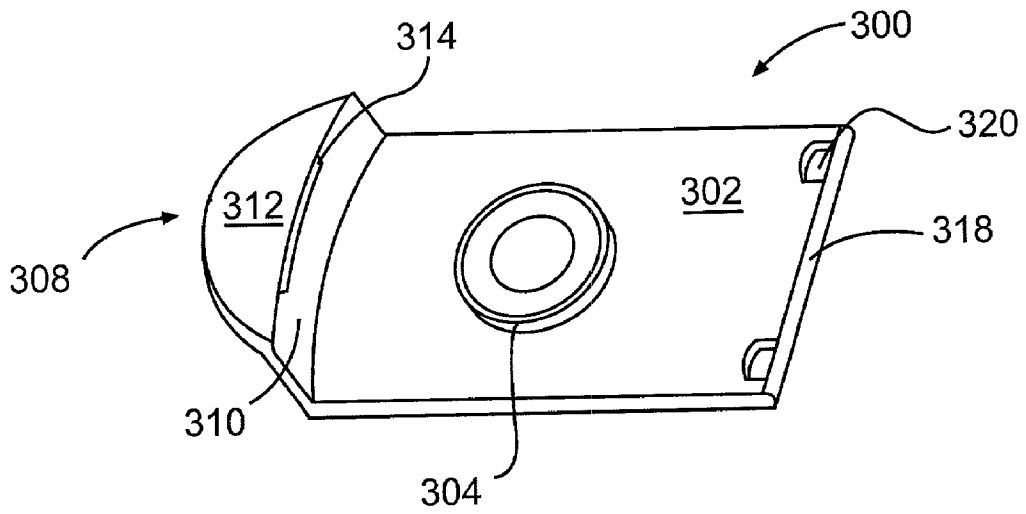

FIG. 2A

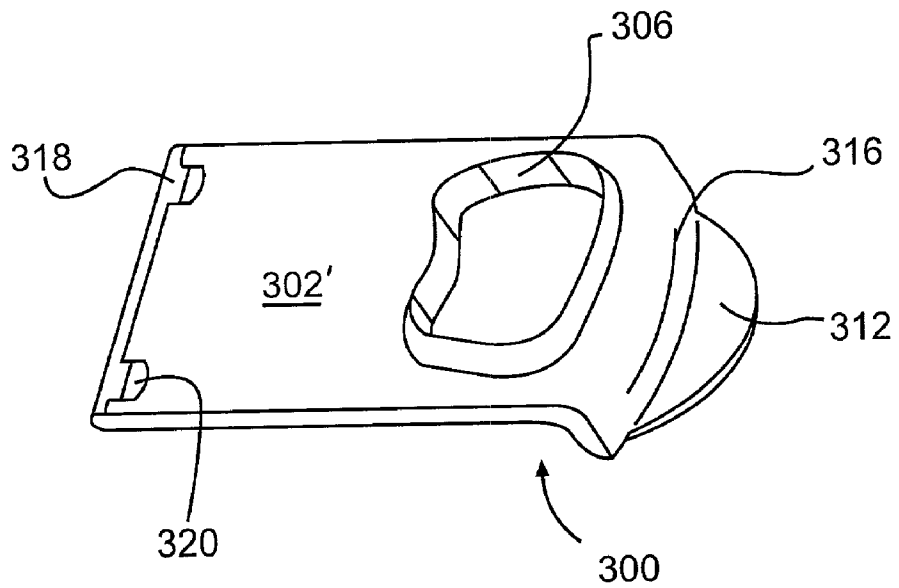

FIG. 2B

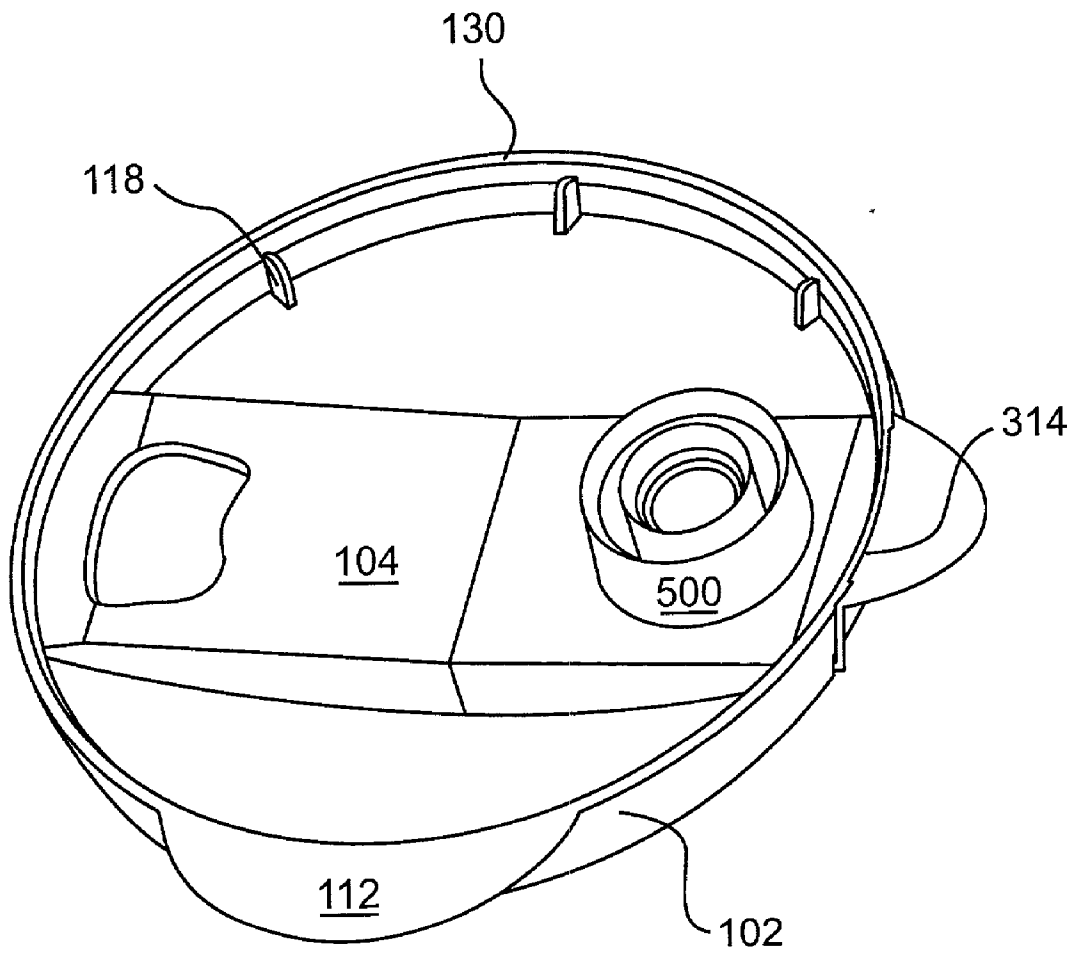

FIG. 3

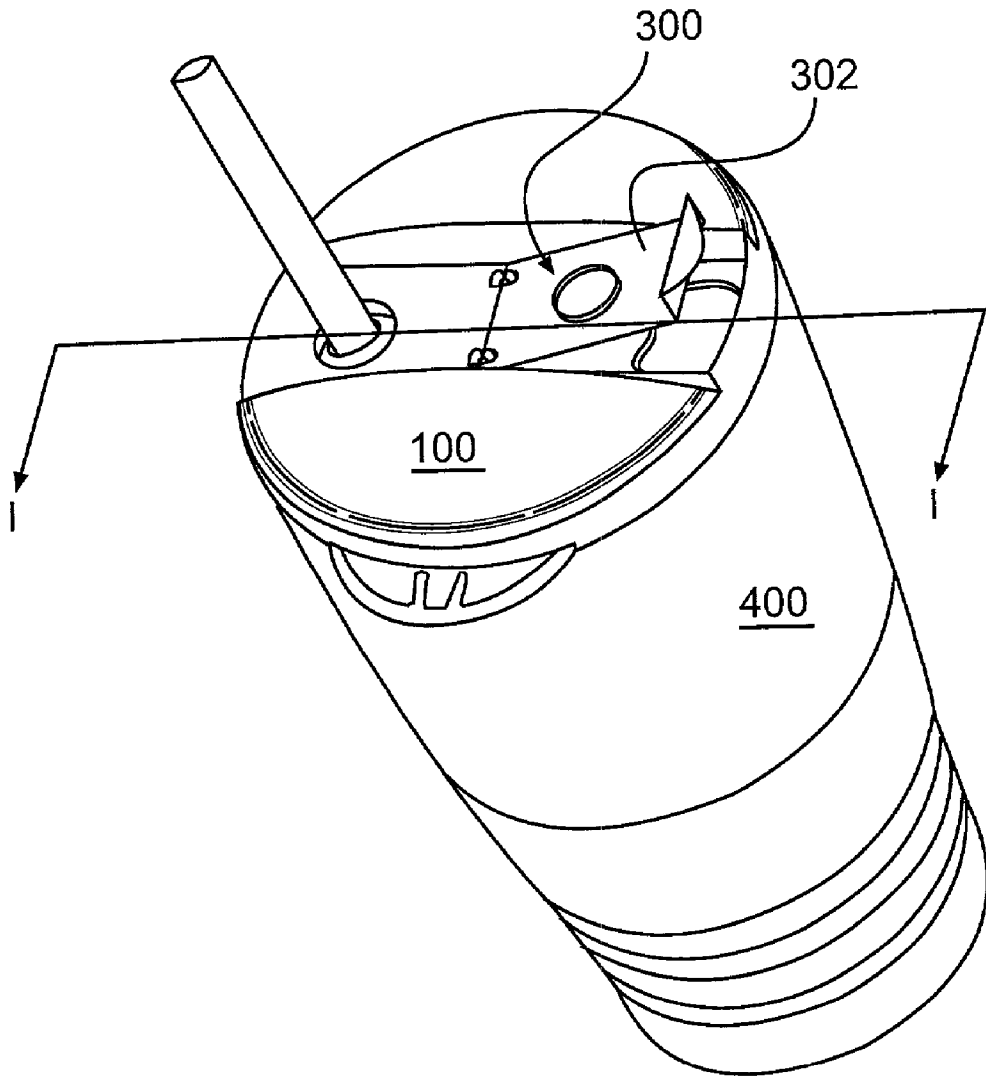

FIG. 4

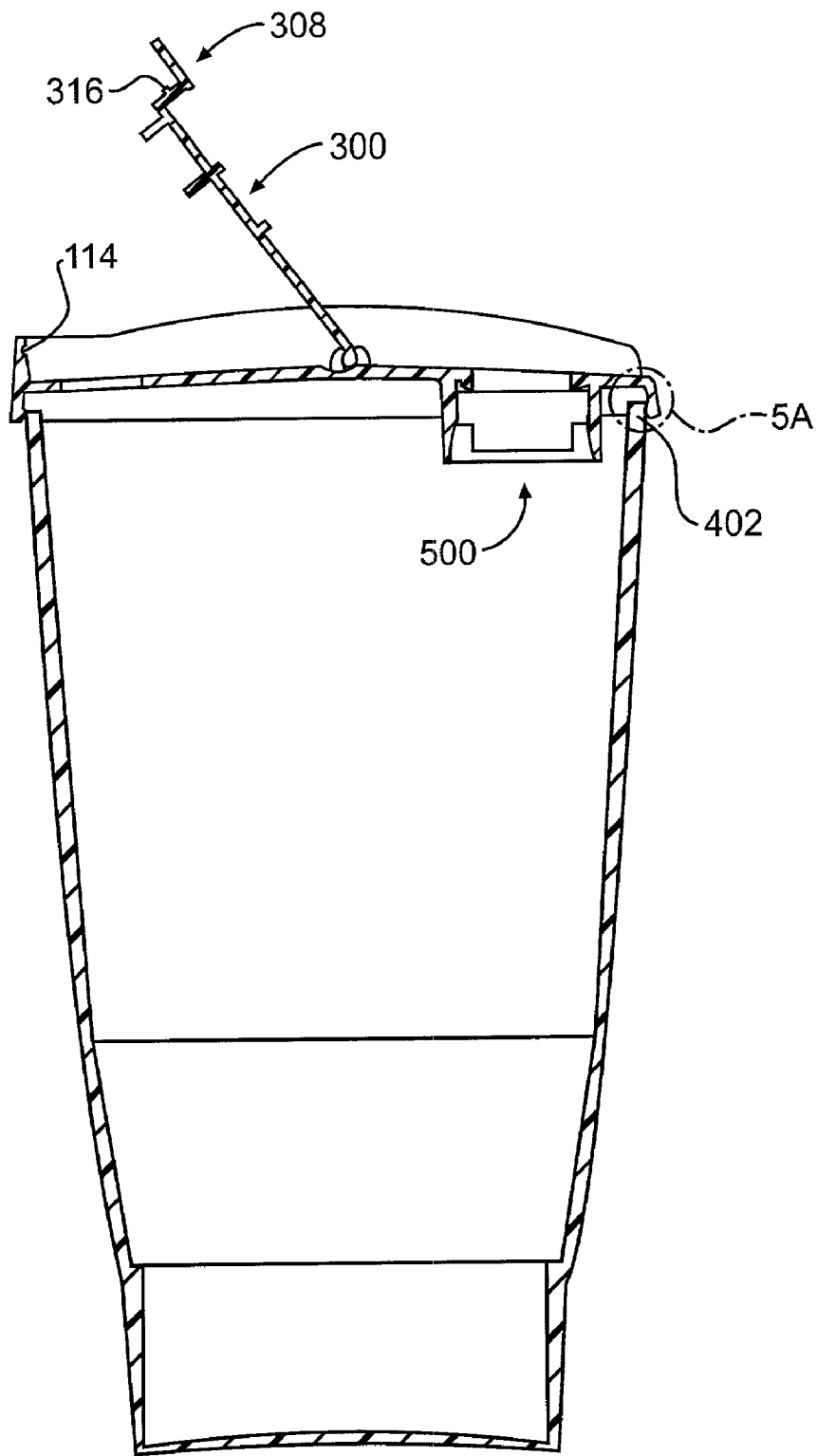

FIG. 5

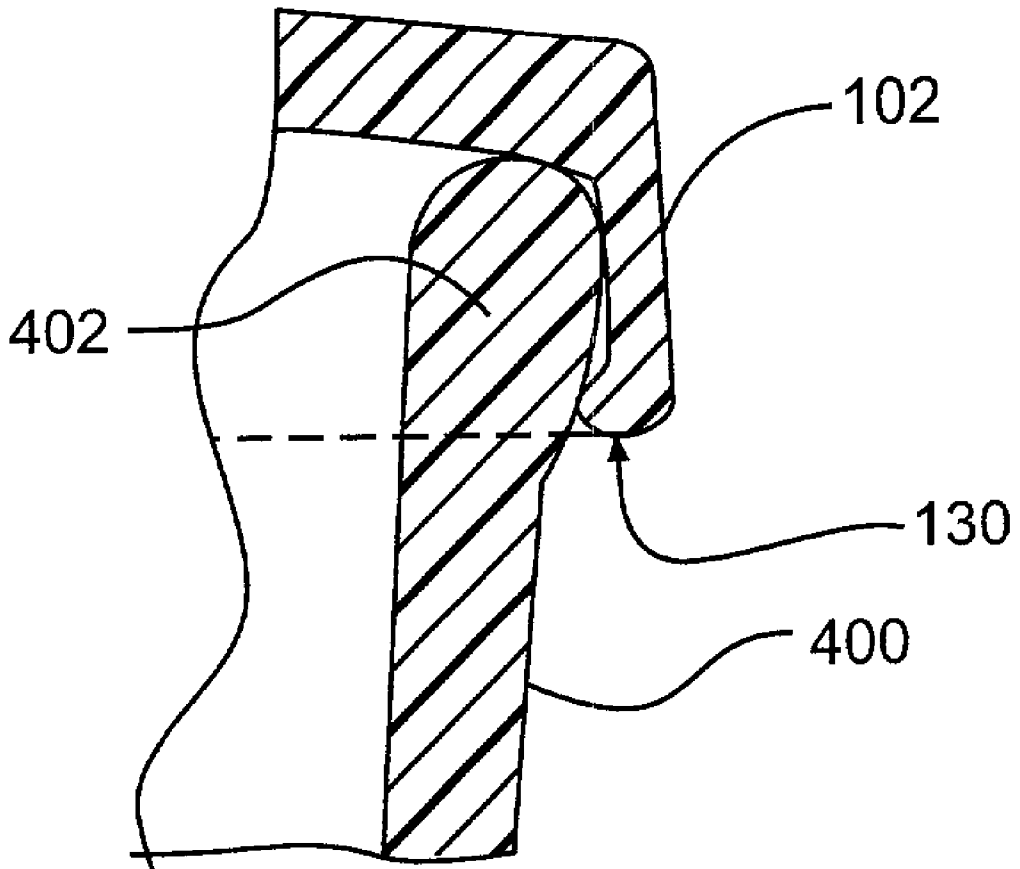

FIG. 5A

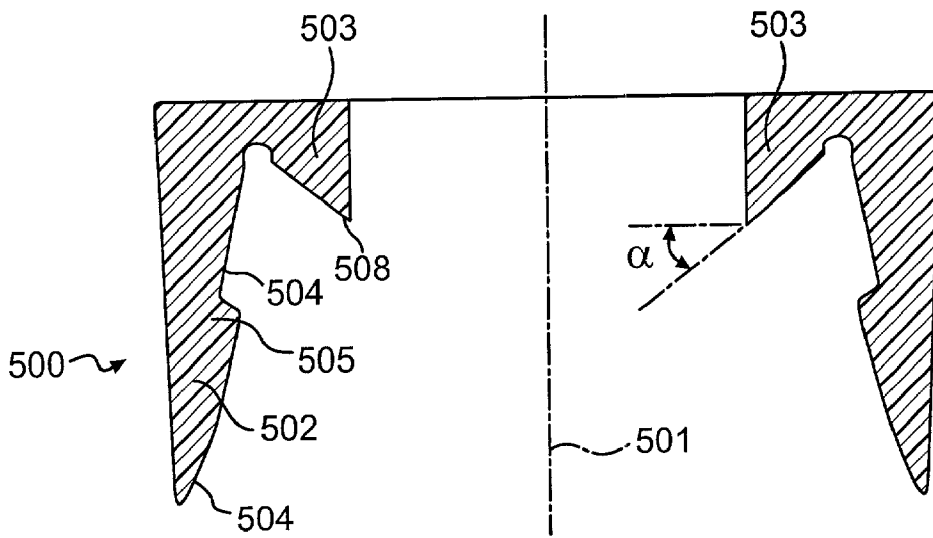

FIG. 6

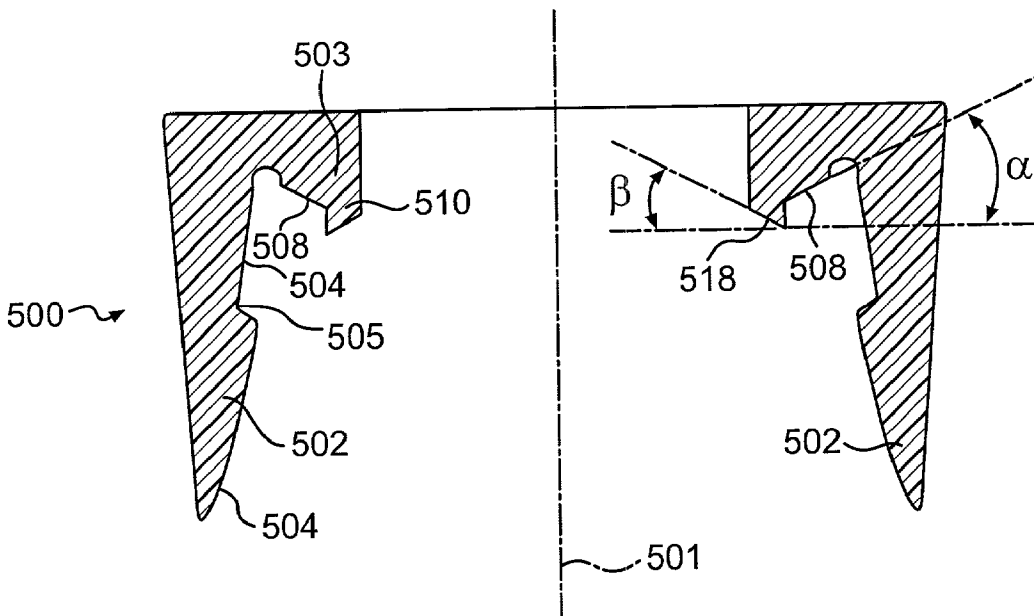

FIG. 7

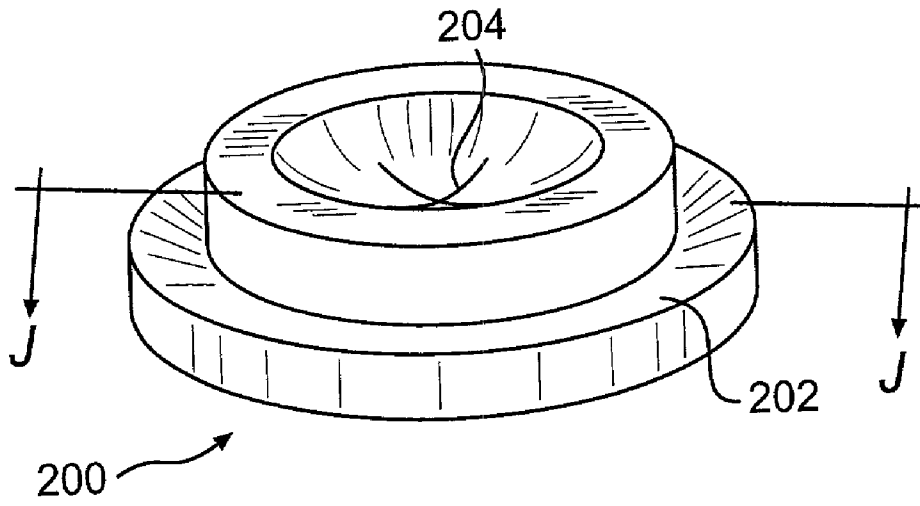

FIG. 8

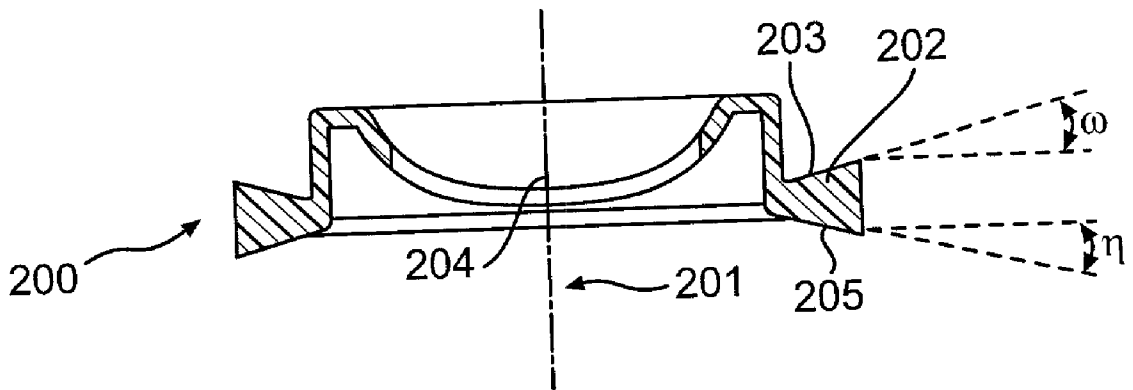

FIG. 9

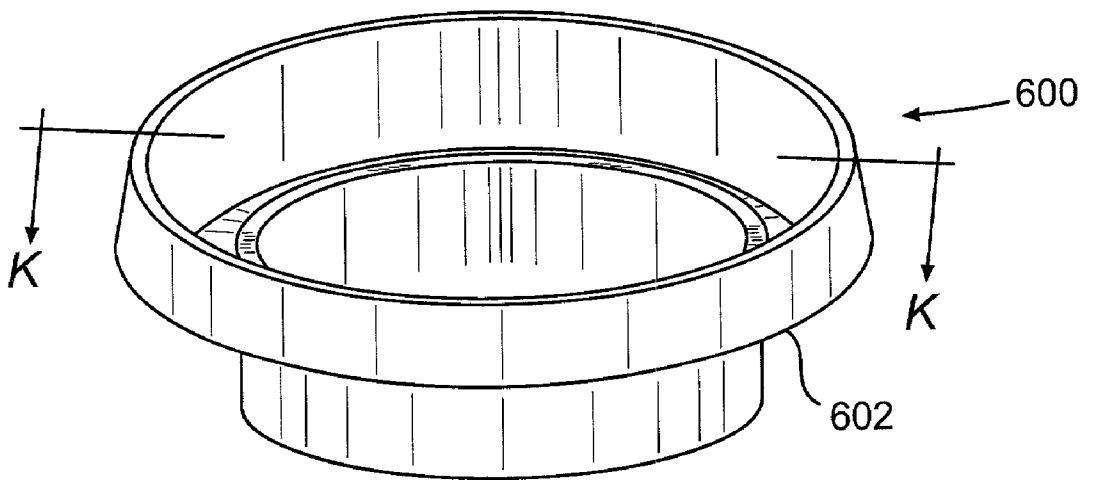

FIG. 10

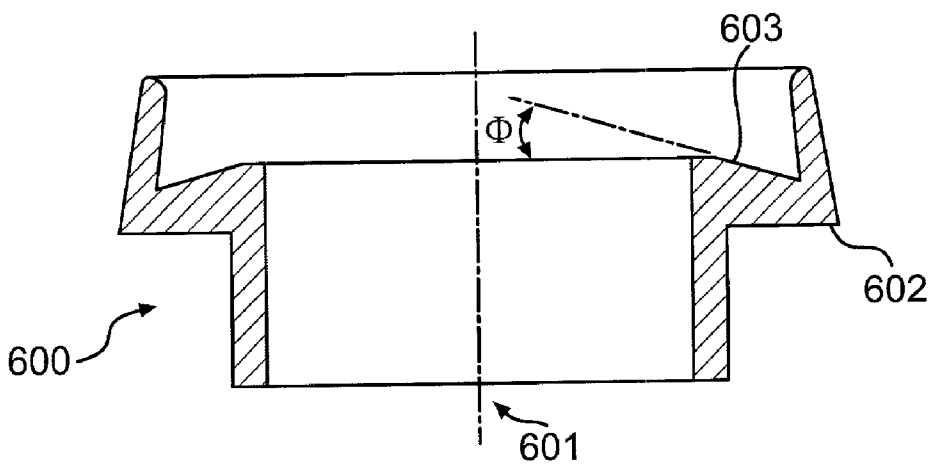

FIG. 11

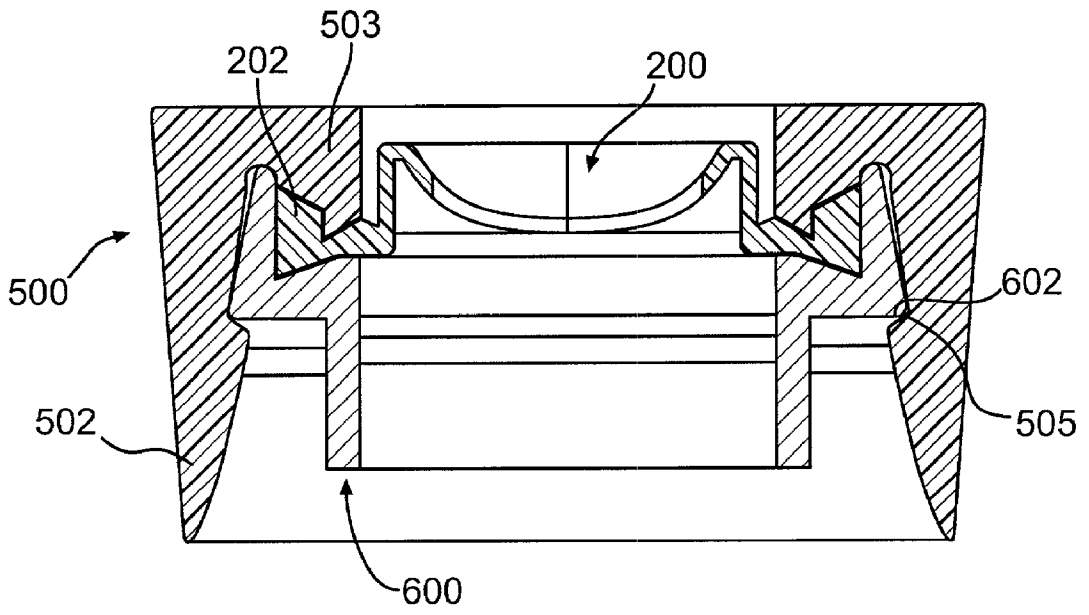

FIG. 12

CONTAINER LID WITH SELECTABLE OPENING AND VALVE ASSEMBLY FOR RETAINING A VALVE

BACKGROUND OF THE INVENTION

[0001] 1. Field of the Invention

[0002] This invention relates generally to a lid for a container, and more particularly, to a removable lid having two apertures therein, a cover adapted to contact either of the two apertures by pivoting on the lid, and a valve assembly for retaining a valve.

[0003] 2. Description of the Related Art

[0004] During outdoor activities, objects in the environment such as flies, mosquitoes, hornets, dust, rain, and the like seem to find their way into open beverage containers. People prefer to avoid contact with such extraneous matter, and especially do not desire to have it in and about the containers from which they drink. Children, and even many adults, sometimes refuse to consume the contents of a container after witnessing various insects moving thereabout. More importantly, consuming a beverage into which minute particles from the air have fallen may prove unhealthy. In addition, whether indoors or outdoors, many people desire a drinking container that does not readily spill its contents when accidentally tipped or dropped.

[0005] Similarly, beverages are often consumed while in a vehicle in motion. Drivers and passengers alike generally desire beverage containers that, when tipped, shaken, or dropped, do not simply spill their contents about the vehicle cabin and its occupants. Further, whether indoors, outdoors, or in a vehicle, not everyone prefers to drink from a container in the same manner. That is, some people prefer to use a straw, while others prefer to simply drink directly from a spout. Moreover, most consumers consider beverage containers to be fungible commodities. As such, a market exists for a simple, low cost, easily manufacturable product that renders a beverage container spill proof, prevents objects from the environment from contacting its contents, and at the same time provides a consumer with the option of consuming its contents either through a straw or directly from a spout.

[0006] Conventional container lids directed towards that market generally include an opening for a straw and an opening for pouring or sipping the contents of a container. Such lids may have pairs of covers to close off the openings, as disclosed by U.S. Pat. No. 5,244,113 to Stymiest, or single removable covers to close off both openings, as disclosed by U.S. Pat. No. 5,415,312 to Mueller. However, the container lid disclosed by Stymiest requires separate first and second closures for closing off the two openings, and both the first and second closures are separately connected to the lid. This increases manufacturing complexity and requires additional assembly steps and material, which raises the cost per lid. The container lid disclosed by Mueller includes a cover that does not attach to the lid. As such, that cover is easily separated and lost.

[0007] Therefore, there is a continuing need in the art for a simple, safe, low-cost, easily-manufacturable container lid having a plurality of apertures therein that can be alternately covered by a single cover, which is hingedly attached to the lid even when none of the plurality of apertures is covered.

SUMMARY OF THE INVENTION

[0008] This invention addresses the foregoing needs in the art by providing a container lid having two apertures therein, and comprising a cover hingedly attached to the lid and adapted to cover one of the two apertures at a time by pivoting on the lid, and a valve assembly for retaining a valve.

[0009] In a first embodiment of the invention, a container lid comprises a cover receiving portion having a first aperture and a second aperture formed therein and having a top side and a bottom side, a valve housing, a valve, a valve retainer, a hinge, and a cover. The valve housing comprises a tubular retaining wall and a valve seat, the tubular retaining wall depending from and being integrally formed with the bottom side of the cover receiving portion and having an inner surface with a shoulder integrally formed therein, the valve seat depending from and being integrally formed with the bottom side of the cover receiving portion. The valve is receivable within the valve housing. The valve retainer has a retainer retention portion, the valve retainer being shaped so as to retain the valve within the tubular retaining wall and against the valve seat via engagement of the retainer retention portion with the shoulder of the tubular retaining wall. The hinge is integrally formed with the cover receiving portion and is positioned so that the first aperture is on one side of the hinge and the second aperture is on an opposite side of the hinge. The cover is attached to the cover receiving portion via the hinge, the cover comprising a first sidewall and a second sidewall opposite the first sidewall, each of the first sidewall and the second sidewall having a protrusion extending therefrom and shaped so as to engage one of the first aperture and the second aperture. The cover is pivotally attached to the lid via the hinge, and the cover pivots relative to the cover receiving portion so that when the protrusion on the first sidewall of the cover is pivoted toward the first aperture, the protrusion on the second sidewall of the cover simultaneously pivots away from the second aperture.

[0010] In another aspect of the first embodiment, the valve seat comprises a first seating surface. The first seating surface is inclined at a first angle relative to a plane orthogonal to a central longitudinal axis of the tubular retaining wall.

[0011] In yet another aspect of the first embodiment, the valve seat further comprises a projection. The projection comprises a second seating surface. The second seating surface is at a second angle relative to a plane orthogonal to the central longitudinal axis of the tubular retaining wall.

[0012] In yet another aspect of the first embodiment, the first angle and the second angle are different; for example, the second angle may be smaller than the first angle, the first angle may be in a range of 22 degrees to 45 degrees, or the first angle may be in a range of 22 degrees to 45 degrees with the second angle being in a range of 5 degrees to 10 degrees.

[0013] In a second embodiment of the invention, a container assembly comprises a container having an upper lip and a lid. The lid is removably attachable to the upper lip of the container. The lid comprises (i) a substantially flat portion, the substantially flat portion having a first aperture and a second aperture formed therein, and having a top side and a bottom side; (ii) a hinge, the hinge being integrally

formed with the substantially flat portion and being positioned so that the first aperture is on one side of the hinge and the second aperture is on an opposite side of the hinge; (iii) a valve housing, the valve housing comprising a tubular retaining wall and a valve seat, the tubular retaining wall depending from and being integrally formed with the bottom side of the substantially flat portion and having an inner surface with a shoulder integrally formed therein, the valve seat depending from and being integrally formed with the bottom side of the substantially flat portion; (iv) a valve, the valve being receivable within the valve housing; (v) a valve retainer, the valve retainer having a retainer retention portion, the valve retainer shaped so as to retain the valve within the tubular retaining wall and against the valve seat via engagement of the retainer retention portion with the shoulder of the tubular retaining wall; (vi) a cover, the cover being attached to the substantially flat portion via the hinge, the cover comprising a first sidewall and a second sidewall opposite the first sidewall, each of the first sidewall and the second sidewall having a protrusion extending therefrom and shaped so as to engage one of the first aperture and the second aperture; and (vii) a peripheral wall, the peripheral wall shaped so as to receive the upper lip therewithin.

[0014] In a third embodiment of the invention, an improved drinking assembly includes a container and a lid, the container having an upper lip, the lid being removably attachable to the upper lip of the container. The lid has (i) a first aperture and a second aperture formed therein and a top side and a bottom side, (ii) a hinge, the hinge being integrally formed with the lid and being positioned so that the first aperture is on one side of the hinge and the second aperture is on an opposite side of the hinge, and (iii) an aperture cover, the aperture cover being attached to the lid via the hinge. The improvement comprises a valve housing, a valve, and a valve retainer. The valve housing comprises a tubular retaining wall and a valve seat. The tubular retaining wall depends from and is integrally formed with the bottom side of the lid and has an inner surface with a shoulder integrally formed therein. The valve seat depends from and is integrally formed with the bottom side of the lid. The valve is receivable within the valve housing. The valve retainer has a retainer retention portion and is shaped so as to retain the valve within the tubular retaining wall and against the valve seat via engagement of the retainer retention portion with the shoulder of the tubular retaining wall.

[0015] In a fourth embodiment of the invention, a valve assembly comprises a valve housing comprising a housing top portion, a tubular retaining wall, and a valve seat. The tubular retaining wall depends from and is integrally formed with the housing top portion and has an inner surface with a shoulder integrally formed therein. The valve seat depends from and is integrally formed with the housing top portion and has a first seating surface. The valve assembly further comprises a valve receivable within the valve housing, the valve comprising a flange having a top flange surface and a bottom flange surface; and a valve retainer having a retainer retention portion and a valve engaging surface, the valve retainer shaped so as to retain the valve within the tubular retaining wall and against the valve seat via engagement of the retainer retention portion with the shoulder of the tubular retaining wall. Furthermore, at least one of (i) the first seating surface is non-complementary to the top flange surface and (ii) the bottom flange surface is non-complementary to the valve engaging surface.

[0016] In a fifth embodiment of the invention, a valve assembly comprises a valve housing comprising a housing top portion, a tubular retaining wall, and a valve seat. The tubular retaining wall depends from and is integrally formed with the housing top portion and has an inner surface with a shoulder integrally formed therein. The valve seat depends from and is integrally formed with the housing top portion and has a first seating surface. The valve seat comprises a projection having a second seating surface. The valve assembly further comprises a valve receivable within the valve housing. The valve comprises a flange having a top flange surface and a bottom flange surface. The valve assembly also comprises a valve retainer having a retainer retention portion and a valve engaging surface, the valve retainer shaped so as to retain said valve within the tubular retaining wall and against the valve seat via engagement of the retainer retention portion with the shoulder of the tubular retaining wall. Furthermore, at least one of (i) the first seating surface is non-complementary to the top flange surface, (ii) the second seating surface is non-complementary to the top flange surface, and (iii) the bottom flange surface is non-complementary to the valve engaging surface.

[0017] In another aspect of the fifth embodiment of the invention, (i) the first seating surface is at a first angle relative to a plane orthogonal to a central longitudinal axis of the tubular retaining wall, (ii) the second seating surface is at a second angle relative to a plane orthogonal to the central longitudinal axis of the tubular retaining wall, (iii) the top flange surface is at a top flange angle relative to a plane orthogonal to a central longitudinal axis of said valve, and (iv) the first angle is greater than the top flange angle. In yet another aspect of the fifth embodiment, at least one of (i) the first angle is about 1 degree to about 25 degrees greater than the top flange angle; (ii) the first angle is about 14 degrees greater than the top flange angle; (iii) the second angle is about 5 degrees to about 10 degrees; and (iv) the second angle is about 6 degrees.

BRIEF DESCRIPTION OF THE DRAWINGS

[0018] FIG. 1 is a perspective view of a top of a lid in accordance with this invention;

[0019] FIGS. 2A and 2B are perspective views of a cover for use in this invention;

[0020] FIG. 3 is a perspective view of an underside of the lid shown in FIG. 1;

[0021] FIG. 4 is a perspective view of the lid in accordance with this invention attached to a container;

[0022] FIG. 5 is a sectional view along the line I-I in FIG. 4 while FIG. 5A is a partial cut-out sectional view of the portion 5A shown in FIG. 5;

[0023] FIGS. 6 and 7 are partial cross-sectional views of a valve housing shown in FIG. 5;

[0024] FIG. 8 is a perspective view of a valve for use in this invention;

[0025] FIG. 9 is a sectional view of the valve taken along the line J-J in FIG. 8;

[0026] FIG. 10 is a perspective view of a valve retainer for use in this invention, which is used to retain a valve in the valve housing;

[0027] FIG. 11 is a sectional view of the valve retainer taken along the line K-K in FIG. 10; and

[0028] FIG. 12 is a partial cross-sectional view of an assembled valve housing, valve, and valve retainer.

DETAILED DESCRIPTION OF THE PREFERRED EMBODIMENTS

[0029] This invention relates generally to a container lid comprising a hinge, a plurality of apertures disposed in the lid and positioned on opposite sides of the hinge, a cover pivotally connected to the lid via the hinge, and a valve assembly for retaining a valve. The cover comprises two sides and a protrusion on each side, each protrusion being adapted to sealingly engage (or alternatively to fit within) one of the plurality of apertures in the lid.

[0030] FIG. 1 shows a perspective view of a lid 100 according to the preferred embodiment. The lid 100 comprises a top 124 and a peripheral wall 102 depending therefrom. A circumference of the top 124 is generally circular, and a cross section of the top 124 is generally arcuate, rising from a low point at a periphery of the top 124 to a high point near a center of the top 124. A cover receiving portion, preferably a flat portion 104, extends across the top 124 and through the center of the top 124. The flat portion 104 comprises at least two apertures formed therein. These apertures in the cover receiving portion can be of the same or different shape and size. Preferably, however, one aperture is, for example, a straw hole 106 suitable for receiving a conventional straw, and another aperture is, for example, a spout 108 suitable for pouring or sipping contents of a container 400 (see FIG. 4). Various shapes for the apertures, such as circular, elliptical, polygonal, rectangular, and the like, can be formed in the flat portion 104 without departing from the scope of the invention. Near the spout 108, the lid 100 further comprises an extending lip 110 to aid in sipping.

[0031] A tongue 112 is provided on one side of the lid 100 and is integrally formed with the peripheral wall 102 to facilitate removal and handling of the lid 100. Of course, the tongue 112 may be a separate piece, or may be disposed of altogether without departing from the scope of the invention. Moreover, the tongue 112 can be a variety of shapes and sizes, such as an arcuate, rectangular, or triangular extension from the lid.

[0032] FIGS. 2A and 2B show a cover 300 for use in this invention. The cover 300 comprises two sides 302, 302' each with a protrusion 304, 306, respectively disposed thereon and shaped to sealingly engage, fit within, or mate with one of the apertures in the flat portion 104. As shown in FIGS. 1, 2A, and 2B, the side 302 of the cover 300 nearest the straw hole 106 includes the protrusion 304, which is shaped similarly to the straw hole 106, and the side 302' of the cover 300 nearest the spout 108 includes the protrusion 306, which is shaped similarly to the spout 108. Of course, the protrusions 304, 306 and the apertures 106, 108 may take on a variety of shapes, such as contoured, elliptical, polygonal, and the like, other than the straw holes and spouts shown.

[0033] As illustrated in FIGS. 2A and 2B, the cover 300 comprises an L-shaped handle 308 extending orthogonally from the side 302. The handle 308 has an orthogonal panel 310 perpendicular to the side 302 and a parallel panel 312 parallel to the side 302, thus forming the L-shaped handle

308. Near a corner formed by an intersection of the panels 310, 312 of the handle 308, a first rib 314 is formed. When the cover 300 is closed over the straw hole 106, the first rib 314 grips a bottom edge of the wall 102, holding the cover 300 closed against the flat portion 104, as illustrated in FIG. 3. The orthogonal panel 310 also includes a second rib 316 that engages with a notch 114, shown in FIG. 5, formed in the lid 100, thus keeping the cover 300 in place over the spout 108. Although the first and second ribs 314, 316 and the notch 114 are preferably provided, they may be omitted without departing from the scope of the invention.

[0034] The cover 300 is pivotally attached to the lid 100 near the middle of the flat portion 104, as shown in FIG. 1. The flat portion 104 comprises at least one pair of protruding forks 116, preferably two pairs of protruding forks 116, and the cover 300 comprises a rod-shaped end 318 and at least one window 320, preferably a pair of windows 320. The rod-shaped end 318 is received by the forks 116 (e.g., the rod-shaped end 318 snaps into the forks 116) at the location of the windows 320, thereby allowing for hinged movement of the cover 300. Of course, other hinge-like structures may be used without departing from the scope of the invention, such as extending the rod-shaped end 318 beyond an end-wall of the cover 300 to form extended pins and using forks or pin receiving means to restrain the cover 300 on the lid 100 via the extended pins.

[0035] An underside of the lid 100 according to the preferred embodiment is shown in FIG. 3. A valve housing 500 depends from and is integrally formed with an underside (i.e., bottom side) of the flat portion 104 and generally surrounds the straw hole 106. A ridge 130 extends around the wall 102, and a plurality of stops 118 protrude from the underside of the lid 100. Three stops 118 are shown; however, there are three additional stops on the opposite side of the flat portion 104 that are obscured by the wall 102 (in FIG. 3). Nevertheless, any number of stops may be provided, from none to a continuous ridge, without departing from the scope of the invention, to provide a mating surface between the lid 100 and the container 400.

[0036] The valve housing 500, shown in FIGS. 3 and 5 and in greater detail in FIGS. 6, 7, and 10, comprises a housing top portion, a tubular retaining wall 502, and a valve seat 503. The tubular retaining wall 502 depends from and is integrally formed with the housing top portion, the housing top portion being integrally formed with the bottom side of the flat portion 104. The tubular retaining wall 502, which is preferably cylindrical in shape, includes an inner surface 504 with a shoulder 505 integrally formed therein. The shoulder 505 is preferably continuous about the circumferential inner surface 504 of the tubular retaining wall 502, but may also be intermittent (i.e., discontinuous), in the form of spaced-apart shoulders. The valve seat 503 also depends from and is integrally formed with the housing top portion, which is integrally formed with the bottom side of the flat portion 104. The valve seat 503 is positioned inside of, or within a perimeter of, the tubular retaining wall 502. In addition, the valve seat 503 is preferably continuous in form; that is, the valve seat 503 is preferably a depending ring-like structure, which may be, for example, cylindrical in shape. However, the valve seat 503 may also be intermittent (i.e., discontinuous), in the form of a plurality of spaced-apart valve seats.

[0037] The valve seat **503** comprises a first seating surface **508**. The first seating surface **508** is inclined at a first angle α relative to a plane orthogonal to a central longitudinal axis **501** of the tubular retaining wall **502**. Alternatively, the valve seat **503** comprises a projection **510** (see FIG. 7), which further depends downwardly from the bottom side of the flat portion **104**. The projection **510** comprises a second seating surface **518**. The second seating surface **518** is inclined at a second angle β relative to a plane orthogonal to the central longitudinal axis **501** of the tubular retaining wall **502**. The valve housing **500**, including the tubular retaining wall **502** and the valve seat **503**, is shaped so as to allow receipt of a valve **200** therewithin.

[0038] FIG. 8 generally shows a perspective view of the valve **200**, which is one example of a valve for use in this invention, and FIG. 9 generally shows a sectional view of the valve **200** taken along the line J-J in FIG. 8. Such valves **200** are produced by Liquid Molding Systems, Inc., Midland, Mich., marketed through Sequist Closures of Mukwanago, Wis., under the SIMPLISQUEEZE line, and typically made of silicone. As shown in FIG. 9, the valve **200** preferably comprises a flange **202** and a plurality of slits **204**. The flange **202** has an upper surface **203** and a lower surface **205**. The upper surface **203** is formed at an angle ω relative to a plane orthogonal to a central longitudinal axis **201** of the valve **200**, and the lower surface **205** is formed at an angle η relative to a plane orthogonal to the central longitudinal axis **201** of the valve **200**. The plurality of slits **204** allows for insertion of an object therethrough, such as a conventional straw. When a straw or similar tube is not inserted through the valve **200**, then the valve **200** provides a spill-proof seal, meaning that fluid contents of the container **400** coming in ephemeral contact with the valve **200** will not pass through the valve **200**.

[0039] The valve **200** is preferably secured within the valve housing **500** via a valve retainer **600**, which is generally shown in FIGS. 10 and 11. The valve retainer **600** preferably comprises a retainer retention portion **602** and a valve engaging surface **603**. The valve engaging surface **603** is formed at an angle Φ relative to a plane orthogonal to a central longitudinal axis **601** of the valve retainer **600**. The valve retainer **600** is shaped so as to retain the valve **200** within the tubular retaining wall **502** and against the valve seat **503** via engagement of the retainer retention portion **602** with the shoulder **505** of the tubular retaining wall **502**, as shown, for example, in FIG. 12. FIG. 12 shows the valve **200** secured within the valve housing **500** using the valve retainer **600**. In order to secure (i.e., retain) the valve **200**, the valve **200** is first placed within the valve housing **500** so that the flange **202** of the valve **200** abuts the valve seat **503**. Then, the valve retainer **600** is pressed within the tubular retaining wall **502**, towards the bottom side of the flat portion **104**, until the retainer retention portion **602** snap-fittingly engages the shoulder **505** of the tubular retaining wall **502**. In this position, the valve retainer **600** exerts a force upon the valve **200**, effectively squeezing the flange **202** between the valve seat **503** and the valve retainer **600**. The valve retainer **600** is preferably snap-fitted within the tubular retaining wall **502**; however, the valve retainer **600** may also be effectively retained in place by alternative means, such as by ultrasonic welding or with adhesives, which may render the shoulder **505** optional.

[0040] The configuration of the valve seat **503** substantially determines the magnitude of the force (e.g., squeezing force) exerted upon the flange **202**, when assembled as shown, for example, in FIG. 12. Consequently, the configuration of the valve seat **503** determines, in significant part, the amount of withdrawal force necessary to forcibly remove the valve **200** from its mounted position in the valve housing **500** through the straw hole **106** (i.e., from the top side of the lid). To this end, various configurations of the valve seat **503** are discussed below with reference to FIGS. 6 and 7.

[0041] A basic configuration of the valve seat **503** has the first angle α of the first seating surface **508** of the valve seat **503** being complementary to the angle ω of the upper surface **203** of the valve **200**, with the angle η of the lower surface **205** of the valve **200** being complementary to the angle Φ of the valve engaging surface **603** of the valve retainer **600**. In this configuration, the first seating surface **508** meets the upper surface **203** and the lower surface **205** meets the valve engaging surface **603**, surface-to-surface, in a complementary fashion (i.e., like pieces of a puzzle). However, in this configuration, the amount of withdrawal force necessary to forcibly remove the valve **200** from its mounted position in the valve housing **500** through the straw hole **106** is less than can be obtained from the following configurations of the valve seat **503**.

[0042] An improved configuration of the valve seat **503**, as shown in FIG. 6, has the first angle α of the first seating surface **508** of the valve seat **503** being different than, and preferably greater than, the angle ω of the upper surface **203** of the valve **200**, with the angle η of the lower surface **205** of the valve **200** being complementary to the angle Φ of the valve engaging surface **603** of the valve retainer **600**. In this configuration, the first seating surface **508** is not complementary with the upper surface **203**, while the lower surface **205** and the valve engaging surface **603** meet each other, surface-to-surface, in a complementary fashion. For example, where the angle ω is 22 degrees, the angle α is selected to be greater than 22 degrees, such as from greater than 22 degrees to 45 degrees, and is preferably selected to be about 36 degrees. In this configuration, the amount of withdrawal force necessary to forcibly remove the valve **200** from its mounted position in the valve housing **500** through the straw hole **106** is greater than the required withdrawal force in the basic configuration of the valve seat **503** discussed above.

[0043] Another improved configuration of the valve seat **503**, as shown in FIG. 7, includes the projection **510** with at least one seating surface, such as the second seating surface **518**. In this configuration, the first angle α of the first seating surface **508** of the valve seat **503** is the same as or different than, and preferably greater than, the angle ω of the upper surface **203** of the valve **200**, and the second angle β of the second seating surface **518** of the valve seat **503** relative to the plane orthogonal to the central longitudinal axis **501** of the tubular retaining wall **502** is zero or greater, with the angle η of the lower surface **205** of the valve **200** remaining complementary to the angle Φ of the valve engaging surface **603** of the valve retainer **600**. Preferably, the second angle β is smaller than the first angle α , so that the first seating surface **508** is not parallel with the second seating surface **518**. In addition, the first seating surface **508** is preferably angled in a direction generally opposite that of the second

seating surface **518**, as shown, by way of example, in **FIG. 7**. For example, where the angle ω is 22 degrees, the angle α is preferably selected to be from 22 degrees to 45 degrees, and the second angle β is preferably selected to be in the range of 5 degrees to 10 degrees, more preferably between 5 degrees and 6 degrees. In this configuration, the second seating surface **518** is not complementary with the upper surface **203**, while the lower surface **205** and the valve engaging surface **603** meet each other, surface-to-surface, in a complementary fashion. Also, in this configuration, the amount of withdrawal force necessary to forcibly remove the valve **200** from its mounted position in the valve housing **500** through the straw hole **106** is again greater than the required withdrawal force in the basic configuration of the valve seat **503** discussed above. Of course, the projection **510** may comprise a plurality of seating surfaces, such as, for example, two second seating surfaces **518** configured to form a point (e.g., a wedge-like projection).

[0044] One resulting feature of each example of the improved configurations of the valve seat **503**, as shown in **FIGS. 6 and 7**, is that the force (e.g., squeezing force) exerted upon the flange **202**, when assembled as shown, for example, in **FIG. 12**, is neither too small nor too great. That is, if the squeezing force were too small, the amount of withdrawal force necessary to forcibly remove the valve **200** from its mounted position in the valve housing **500** through the straw hole **106** would likewise be small. Similarly, if the squeezing force were too great, the flange **202** of the valve **200** would act like a compressed spring and cause the valve retainer **600** to dislodge from its snap-fitted position within the tubular retaining wall **502**. As such, a person of ordinary skill in this art would appreciate that the particular configuration of the valve seat **503**, including its optional projection **510**, is dependent, at least in part, on (i) the particular material(s) comprising the valve **200**, the valve retainer **600**, and the valve housing **500**, (2) the particular shape of the flange **202** of the valve **200**, including the angle η of the lower surface **205** of the valve **200** and the angle ω of the upper surface **203** of the valve **200**, and (3) the selected means for securing the valve retainer **600** within the tubular retaining wall **502**.

[0045] In addition, although the above discussion was directed to manipulating the valve seat **503** with respect to the upper surface **203** of the valve **200**, a person of ordinary skill in this art would recognize that the same or equivalent features may be provided on the valve engaging surface **603** of the valve retainer **600** with respect to the lower surface **205** of the valve **200**, as additional features or with the upper surface **203** and the valve seat **503** configured to meet each other, surface-to-surface, in a complementary fashion.

[0046] The lid **100** is removably attachable to a container **400** having a flared top **402**, as shown in **FIG. 4**. As illustrated in **FIGS. 5 and 5A**, the ridge **130** of the lid **100** contacts the flared top **402** to removably secure the lid **100** to the container **400**. When the lid **100** is secured to the container **400**, a seal is formed as the ridge **130** contacts the flared top **402**. This seal may be a leak-resistant, a leak-proof, or a spill-proof seal. Preferably, the seal formed is a leak-proof seal. Also, when the lid **100** is secured to the container **400**, the stops **118** abut the flared top **402** of the container **400**. Moreover, in another aspect of the invention, the lid **100** preferably snaps onto or snap-fittingly engages

with the container **400**, thus producing a snapping sound upon properly attaching the lid **100** to the container **400**.

[0047] The lid **100**, cover **300**, and container **400** can be manufactured from a variety of materials, but are preferably plastic. Such plastics include high density polyethylene (HDPE), any polyolefin, including but not limited to linear low density polyethylene (LLDPE), polypropylene (PP), and low density polyethylene (LDPE). The plastics used should preferably provide a rigidity between that of LDPE and polypropylene. That is, the plastics used should preferably be rigid enough to provide a solid snapping sound when the lid **100** and the container **400** are attached together, but pliable enough to provide a leak-proof seal therebetween.

[0048] In operation, the lid **100** is attached to the container **400** containing a fluid, such as a beverage, and the cover **300** is selectively snapped down over one of the apertures, such as the spout **108**, as shown in **FIG. 4**. A conventional straw can then be placed into the straw hole **106**. Alternatively, if a user chooses to drink out of the spout **108**, the user can remove the straw and pivot the cover **300** so as to cover the straw hole **106** and expose the spout **108**. When done drinking, the user may pivot the cover **300** back over the spout **108**. In this position, the cover **300** seals the spout **108** to prevent fluid leakage, and the valve **200** prevents fluid leakage through the straw hole **106** in the event the container **400** is tipped over.

INDUSTRIAL APPLICABILITY

[0049] This invention provides a container lid for removable attachment to a container. This lid includes apertures, such as a straw aperture and a spout aperture, through which a user may withdraw contents of the container, and a pivotally attached cover for selectively sealing the apertures. This lid allows a user to consume the contents of the container through a straw or from a spout, while preventing external environmental objects from contacting the contents and preventing accidental spilling of the contents. When not consuming the container contents, a user may seal the spout aperture with the cover and allow a gasket within the straw aperture to seal that aperture. In this state, the lid substantially prevents the container contents from contacting the environment external thereto, thus making this invention highly suitable for use outdoors or in vehicles.

[0050] While this invention has been described with reference to what are currently considered to be the preferred embodiments, it is to be understood that the invention is not limited to the disclosed embodiments. On the contrary, the invention is intended to cover various modifications and equivalent arrangements included within the spirit and scope of the appended claims. The scope of the following claims is to be accorded the broadest interpretation so as to encompass all such modifications and equivalent structures and functions.

We claim:

1. A valve assembly comprising:

a valve housing comprising a housing top portion, a tubular retaining wall, and a valve seat, said tubular retaining wall depending from and being integrally formed with said housing top portion and having an inner surface with a shoulder integrally formed therein,

- said valve seat depending from and being integrally formed with said housing top portion and having a first seating surface;
- a valve receivable within said valve housing, said valve comprising a flange having a top flange surface and a bottom flange surface; and
 - a valve retainer having a retainer retention portion and a valve engaging surface, said valve retainer being shaped so as to retain said valve within said tubular retaining wall and against said valve seat via engagement of the retainer retention portion with the shoulder of said tubular retaining wall, wherein at least one of (i) the first seating surface is non-complementary to the top flange surface and (ii) the bottom flange surface is non-complementary to the valve engaging surface.
2. A valve assembly according to claim 1 wherein (i) the first seating surface is at a first angle relative to a plane orthogonal to a central longitudinal axis of said tubular retaining wall, (ii) the top flange surface is at a top flange angle relative to a plane orthogonal to a central longitudinal axis of said valve, and (iii) the first angle is greater than the top flange angle.
 3. A valve assembly according to claim 2, wherein the first angle is about 1 degree to about 25 degrees greater than the top flange angle.
 4. A valve assembly according to claim 2, wherein the first angle is about 14 degrees greater than the top flange angle.
 5. A valve assembly comprising:
 - a valve housing comprising a housing top portion, a tubular retaining wall, and a valve seat, said tubular retaining wall depending from and being integrally formed with said housing top portion and having an inner surface with a shoulder integrally formed therein, said valve seat depending from and being integrally formed with said housing top portion and having a first seating surface, said valve seat comprising a projection having a second seating surface;
 - a valve receivable within said valve housing, said valve comprising a flange having a top flange surface and a bottom flange surface; and
 - a valve retainer having a retainer retention portion and a valve engaging surface, said valve retainer being shaped so as to retain said valve within said tubular retaining wall and against said valve seat via engagement of the retainer retention portion with the shoulder of said tubular retaining wall, wherein at least one of (i) the first seating surface is non-complementary to the top flange surface, (ii) the second seating surface is non-complementary to the top flange surface, and (iii) the bottom flange surface is non-complementary to the valve engaging surface.
 6. A valve assembly according to claim 5, wherein (i) the first seating surface is at a first angle relative to a plane orthogonal to a central longitudinal axis of said tubular retaining wall, (ii) the second seating surface is at a second angle relative to a plane orthogonal to the central longitudinal axis of said tubular retaining wall, (iii) the top flange surface is at a top flange angle relative to a plane orthogonal to a central longitudinal axis of said valve, and (iv) the first angle is greater than the top flange angle.
 7. A valve assembly according to claim 6, wherein the first angle is about 1 degree to about 25 degrees greater than the top flange angle.
 8. A valve assembly according to claim 6, wherein the first angle is about 14 degrees greater than the top flange angle.
 9. A valve assembly according to claim 6, wherein the second angle is about 5 degrees to about 10 degrees.
 10. A valve assembly according to claim 6, wherein the second angle is about 6 degrees.
 11. A valve assembly according to claim 5, wherein (i) the first seating surface is at a first angle relative to a plane orthogonal to a central longitudinal axis of said tubular retaining wall, (ii) the second seating surface is at a second angle relative to a plane orthogonal to the central longitudinal axis of said tubular retaining wall, (iii) the top flange surface is at a top flange angle relative to a plane orthogonal to a central longitudinal axis of said valve, and (iv) the second angle is greater than zero.
 12. A valve assembly according to claim 11, wherein the second angle is about 5 degrees to about 10 degrees.
 13. A valve assembly according to claim 11, wherein the second angle is about 6 degrees.
 14. A valve assembly according to claim 5, wherein (i) the first seating surface is at a first angle relative to a plane orthogonal to a central longitudinal axis of said tubular retaining wall, (ii) the second seating surface is at a second angle relative to a plane orthogonal to the central longitudinal axis of said tubular retaining wall, (iii) the top flange surface is at a top flange angle relative to a plane orthogonal to a central longitudinal axis of said valve, and (iv) the first angle and the second angle are different.
 15. A valve assembly according to claim 14, wherein at least one of the first angle and the second angle is different than the top flange angle.
 16. A valve assembly according to claim 14, wherein the second angle is smaller than the first angle.
 17. A valve assembly according to claim 14, wherein the first angle is about 22 degrees to about 45 degrees.
 18. A valve assembly according to claim 14, wherein the first angle is about 30 degrees to about 40 degrees.
 19. A valve assembly according to claim 14, wherein the first angle is about 36 degrees.
 20. A valve assembly according to claim 14, wherein the first angle is about 22 degrees to about 45 degrees and the second angle is about 5 degrees to about 10 degrees.
 21. A lid comprising:
 - a cover receiving portion having a first aperture and a second aperture formed therein, and having a top side and a bottom side;
 - a valve housing comprising a tubular retaining wall and a valve seat, said tubular retaining wall depending from and being integrally formed with the bottom side of said cover receiving portion and having an inner surface with a shoulder integrally formed therein, said valve seat depending from and being integrally formed with the bottom side of said cover receiving portion;
 - a valve receivable within said valve housing;
 - a valve retainer having a retainer retention portion, said valve retainer shaped so as to retain said valve within said tubular retaining wall and against said valve seat via engagement of the retainer retention portion with the shoulder of said tubular retaining wall;
 - a hinge integrally formed with said cover receiving portion and positioned so that the first aperture is on one side of said hinge and the second aperture is on an opposite side of said hinge; and

- a cover attached to said cover receiving portion via said hinge, said cover comprising a first sidewall and a second sidewall opposite said first sidewall, each of said first sidewall and said second sidewall having a protrusion extending therefrom and shaped so as to engage one of the first aperture and the second aperture, wherein said cover is pivotally attached to said lid via said hinge, and said cover pivots relative to said cover receiving portion so that when the protrusion on said first sidewall of said cover is pivoted toward the first aperture, the protrusion on said second sidewall of said cover simultaneously pivots away from the second aperture.
- 22.** A lid according to claim 21, said valve seat comprising a first seating surface, said first seating surface being inclined at a first angle relative to a plane orthogonal to a central longitudinal axis of said tubular retaining wall.
- 23.** A lid according to claim 22, said valve seat further comprising a projection, said projection comprising a second seating surface, said second seating surface being at a second angle relative to the plane orthogonal to the central longitudinal axis of said tubular retaining wall.
- 24.** A lid according to claim 23, wherein the first angle and the second angle are different.
- 25.** A lid according to claim 24, wherein the second angle is smaller than the first angle.
- 26.** A lid according to claim 22, wherein the first angle is about 22 degrees to about 45 degrees.
- 27.** A lid according to claim 22, wherein the first angle is about 30 degrees to about 40 degrees.
- 28.** A lid according to claim 22, wherein the first angle is about 36 degrees.
- 29.** A lid according to claim 23, wherein the first angle is about 22 degrees to about 45 degrees and the second angle is about 5 degrees to about 10 degrees.
- 30.** An assembly from which to drink, said assembly comprising:
- a container having an upper lip; and
 - a lid removably attachable to the upper lip of said container, said lid comprising (i) a substantially flat portion having a first aperture and a second aperture formed therein, and having a top side and a bottom side; (ii) a hinge integrally formed with said substantially flat portion and positioned so that the first aperture is on one side of said hinge and the second aperture is on an opposite side of said hinge; (iii) a valve housing comprising a tubular retaining wall and a valve seat, said tubular retaining wall depending from and being integrally formed with the bottom side of said substantially flat portion and having an inner surface with a shoulder integrally formed therein, said valve seat depending from and being integrally formed with the bottom side of said substantially flat portion; (iv) a valve receivable within said valve housing; (v) a valve retainer having a retainer retention portion, said valve retainer shaped so as to retain said valve within said tubular retaining wall and against said valve seat via engagement of the retainer retention portion with the shoulder of said tubular retaining wall; (vi) a cover attached to said substantially flat portion via said hinge, said cover comprising a first sidewall and a second sidewall opposite said first sidewall, each of said first sidewall and said second sidewall having a protrusion extending therefrom and shaped so as to engage one of the first aperture and the second aperture; and (vii) a peripheral wall shaped so as to receive the upper lip therewithin.
- 31.** An assembly according to claim 30, said valve seat comprising a first seating surface, said first seating surface being inclined at a first angle relative to a plane orthogonal to a central longitudinal axis of said tubular retaining wall.
- 32.** An assembly according to claim 31, said valve seat further comprising a projection, said projection comprising a second seating surface, said second seating surface being at a second angle relative to the plane orthogonal to the central longitudinal axis of said tubular retaining wall.
- 33.** An assembly according to claim 32, wherein the first angle and the second angle are different.
- 34.** An assembly according to claim 33, wherein the second angle is smaller than the first angle.
- 35.** An assembly according to claim 31, wherein the first angle is about 22 degrees to about 45 degrees.
- 36.** An assembly according to claim 31, wherein the first angle is about 30 degrees to about 40 degrees.
- 37.** An assembly according to claim 31, wherein the first angle is about 36 degrees.
- 38.** An assembly according to claim 32, wherein the first angle is about 22 degrees to about 45 degrees and the second angle is about 5 degrees to about 10 degrees.
- 39.** An improved assembly from which to drink including a container and a lid, the lid having (i) a first aperture and a second aperture formed therein and a top side and a bottom side, (ii) a hinge positioned so that the first aperture is on one side of the hinge and the second aperture is on an opposite side of the hinge, and (iii) an aperture cover pivoting via the hinge, the improvement comprising:
- a valve housing comprising a tubular retaining wall and a valve seat, said tubular retaining wall depending from and being integrally formed with the bottom side of the lid and having an inner surface with a shoulder integrally formed therein, said valve seat depending from and being integrally formed with the bottom side of the lid and having a first seating surface;
 - a valve receivable within said valve housing, said valve comprising a flange having a top flange surface and a bottom flange surface; and
 - a valve retainer having a retainer retention portion and a valve engaging surface, said valve retainer shaped so as to retain said valve within said tubular retaining wall and against said valve seat via engagement of the retainer retention portion with the shoulder of said tubular retaining wall, wherein at least one of (i) the first seating surface is non-complementary to the top flange surface and (ii) the bottom flange surface is non-complementary to the valve engaging surface.
- 40.** An improved assembly according to claim 39 wherein (i) the first seating surface is at a first angle relative to a plane orthogonal to a central longitudinal axis of said tubular retaining wall, (ii) the top flange surface is at a top flange angle relative to a plane orthogonal to a central longitudinal axis of said valve, and (iii) the first angle is greater than the top flange angle.

41. An improved assembly according to claim 40, wherein the first angle is about 1 degree to about 25 degrees greater than the top flange angle.

42. An improved assembly according to claim 40, wherein the first angle is about 14 degrees greater than the top flange angle.

43. An improved assembly from which to drink including a container and a lid, the lid having (i) a first aperture and a second aperture formed therein and a top side and a bottom side, (ii) a hinge positioned so that the first aperture is on one side of the hinge and the second aperture is on an opposite side of the hinge, and (iii) an aperture cover pivoting via the hinge, the improvement comprising:

a valve housing comprising a tubular retaining wall and a valve seat, said tubular retaining wall depending from and being integrally formed with the bottom side of the lid and having an inner surface with a shoulder integrally formed therein, said valve seat depending from and being integrally formed with the bottom side of the lid and having a first seating surface, said valve seat comprising a projection having a second seating surface;

a valve receivable within said valve housing, said valve comprising a flange having a top flange surface and a bottom flange surface; and

a valve retainer having a retainer retention portion and a valve engaging surface, said valve retainer shaped so as to retain said valve within said tubular retaining wall and against said valve seat via engagement of the retainer retention portion with the shoulder of said tubular retaining wall, wherein at least one of (i) the first seating surface is non-complementary to the top flange surface, (ii) the second seating surface is non-complementary to the top flange surface, and (iii) the bottom flange surface is non-complementary to the valve engaging surface.

44. An improved assembly according to claim 43, wherein (i) the first seating surface is at a first angle relative to a plane orthogonal to a central longitudinal axis of said tubular retaining wall, (ii) the second seating surface is at a second angle relative to a plane orthogonal to the central longitudinal axis of said tubular retaining wall, (iii) the top flange surface is at a top flange angle relative to a plane orthogonal to a central longitudinal axis of said valve, and (iv) the first angle is greater than the top flange angle.

45. An improved assembly according to claim 44, wherein the first angle is about 1 degree to about 25 degrees greater than the top flange angle.

46. An improved assembly according to claim 44, wherein the first angle is about 14 degrees greater than the top flange angle.

47. An improved assembly according to claim 44, wherein the second angle is about 5 degrees to about 10 degrees.

48. An improved assembly according to claim 44, wherein the second angle is about 6 degrees.

49. An improved assembly according to claim 43, wherein (i) the first seating surface is at a first angle relative to a plane orthogonal to a central longitudinal axis of said tubular retaining wall, (ii) the second seating surface is at a second angle relative to a plane orthogonal to the central longitudinal axis of said tubular retaining wall, (iii) the top flange surface is at a top flange angle relative to a plane orthogonal to a central longitudinal axis of said valve, and (iv) the second angle is greater than zero.

50. An improved assembly according to claim 49, wherein the second angle is about 5 degrees to about 10 degrees.

51. An improved assembly according to claim 49, wherein the second angle is about 6 degrees.

52. An improved assembly according to claim 43, wherein (i) the first seating surface is at a first angle relative to a plane orthogonal to a central longitudinal axis of said tubular retaining wall, (ii) the second seating surface is at a second angle relative to a plane orthogonal to the central longitudinal axis of said tubular retaining wall, (iii) the top flange surface is at a top flange angle relative to a plane orthogonal to a central longitudinal axis of said valve, and (iv) the first angle and the second angle are different.

53. An improved assembly according to claim 52, wherein at least one of the first angle and the second angle is different than the top flange angle.

54. An improved assembly according to claim 52, wherein the second angle is smaller than the first angle.

55. An improved assembly according to claim 52, wherein the first angle is about 22 degrees to about 45 degrees.

56. An improved assembly according to claim 52, wherein the first angle is about 30 degrees to about 40 degrees.

57. An improved assembly according to claim 52, wherein the first angle is about 36 degrees.

58. An improved assembly according to claim 52, wherein the first angle is about 22 degrees to about 45 degrees and the second angle is about 5 degrees to about 10 degrees.

* * * * *