

(19) World Intellectual Property Organization
International Bureau



(43) International Publication Date
3 November 2005 (03.11.2005)

PCT

(10) International Publication Number
WO 2005/102199 A1

(51) International Patent Classification⁷: A61B 18/18

(21) International Application Number:
PCT/US2005/013424

(22) International Filing Date: 19 April 2005 (19.04.2005)

(25) Filing Language: English

(26) Publication Language: English

(30) Priority Data:
60/563,581 19 April 2004 (19.04.2004) US

(71) Applicant (for all designated States except US):
PRORHYTHM, INC. [US/US]; 105 Comac Street,
Ronkonkoma, NY 11779 (US).

(72) Inventors; and

(75) Inventors/Applicants (for US only): WARNKING, Reinhard [US/US]; 143 Old Field Road, E. Setauket, NY 11733

(US). JUNG, Eugene [US/US]; 74 Main Street, Setauket, NY 11733 (US). NAKAGAWA, Hiroshi [JP/US]; 12-16 N.W. 195th Street, Edmond, OK 73003 (US). PACHECO, Robert, C. [US/US]; 232 Townline Road, Commack, NY 11725 (US).

(74) Agents: MILLET, Marcus, J. et al.; Lerner, David, Lit-tenberg, Krumholz & Mentlik, LLP, 600 South Avenue West, Westfield, NJ 07090 (US).

(81) Designated States (unless otherwise indicated, for every kind of national protection available): AE, AG, AL, AM, AT, AU, AZ, BA, BB, BG, BR, BW, BY, BZ, CA, CH, CN, CO, CR, CU, CZ, DE, DK, DM, DZ, EC, EE, EG, ES, FI, GB, GD, GE, GH, GM, HR, HU, ID, IL, IN, IS, JP, KE, KG, KM, KP, KR, KZ, LC, LK, LR, LS, LT, LU, LV, MA, MD, MG, MK, MN, MW, MX, MZ, NA, NI, NO, NZ, OM, PG, PH, PL, PT, RO, RU, SC, SD, SE, SG, SK, SL, SM, SY, TJ, TM, TN, TR, TT, TZ, UA, UG, US, UZ, VC, VN, YU, ZA, ZM, ZW.

[Continued on next page]

(54) Title: ABLATION DEVICES WITH SENSOR STRUCTURES

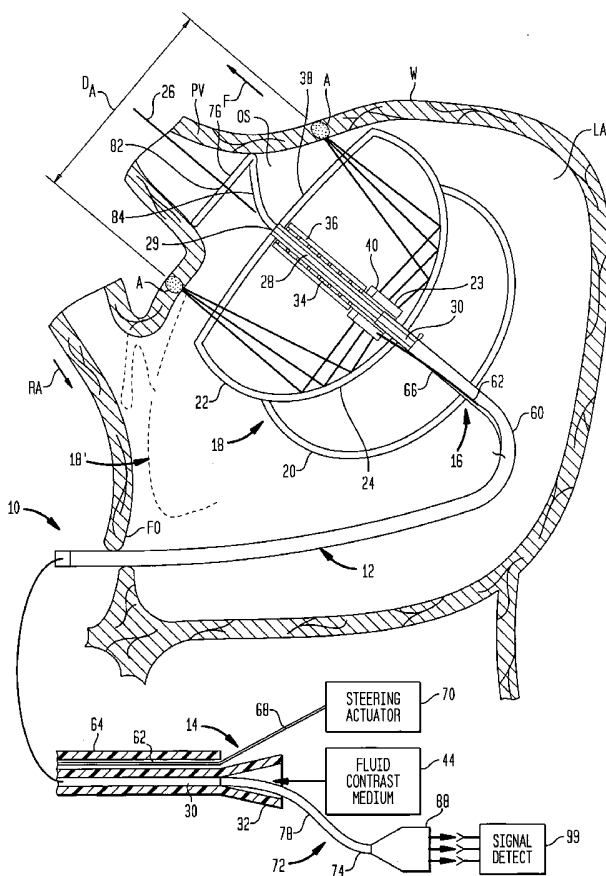

(57) Abstract: A cardiac ablation device, including a steerable catheter (10) and an expandable ablation element (18) incorporating one or more balloons (20, 22) at the distal end of the catheter, has a continuous passageway (28, 30) extending through it from the proximal end of the catheter to the distal side of the expandable ablation element. A probe (72) carrying electrodes is introduced through this passageway and deploys, under the influence of its own resilience, to a structure incorporating a loop (82) which is automatically aligned with the axis of the expandable ablation device, so that minimal manipulation is required to place the sensor probe.

WO 2005/102199 A1



(84) **Designated States** (unless otherwise indicated, for every kind of regional protection available): ARIPO (BW, GH, GM, KE, LS, MW, MZ, NA, SD, SL, SZ, TZ, UG, ZM, ZW), Eurasian (AM, AZ, BY, KG, KZ, MD, RU, TJ, TM), European (AT, BE, BG, CH, CY, CZ, DE, DK, EE, ES, FI, FR, GB, GR, HU, IE, IS, IT, LT, LU, MC, NL, PL, PT, RO, SE, SI, SK, TR), OAPI (BF, BJ, CF, CG, CI, CM, GA, GN, GQ, GW, ML, MR, NE, SN, TD, TG).

Declarations under Rule 4.17:

— as to applicant's entitlement to apply for and be granted a patent (Rule 4.17(ii)) for the following designations AE, AG, AL, AM, AT, AU, AZ, BA, BB, BG, BR, BW, BY, BZ, CA, CH, CN, CO, CR, CU, CZ, DE, DK, DM, DZ, EC, EE, EG, ES, FI, GB, GD, GE, GH, GM, HR, HU, ID, IL, IN, IS, JP, KE, KG, KM, KP, KR, KZ, LC, LK, LR, LS, LT, LU, LV, MA, MD, MG, MK, MN, MW, MX, MZ, NA, NI, NO, NZ, OM, PG, PH, PL, PT, RO, RU, SC, SD, SE, SG, SK, SL, SM, SY, TJ, TM, TN, TR, TT, TZ, UA, UG, UZ, VC, VN, YU, ZA, ZM, ZW, ARIPO patent (BW, GH, GM, KE, LS, MW, MZ, NA, SD, SL, SZ, TZ, UG, ZM, ZW), Eurasian patent (AM, AZ, BY, KG, KZ, MD, RU, TJ, TM), European patent (AT, BE, BG, CH, CY, CZ, DE, DK, EE, ES, FI, FR, GB, GR, HU, IE, IS, IT, LT, LU, MC, NL, PL, PT, RO, SE, SI, SK, TR), OAPI patent (BF, BJ, CF, CG, CI, CM, GA, GN, GQ, GW, ML, MR, NE, SN, TD, TG)

— as to the applicant's entitlement to claim the priority of the earlier application (Rule 4.17(iii)) for the following designations AE, AG, AL, AM, AT, AU, AZ, BA, BB, BG, BR, BW, BY, BZ, CA, CH, CN, CO, CR, CU, CZ, DE, DK, DM, DZ, EC, EE, EG, ES, FI, GB, GD, GE, GH, GM, HR, HU, ID, IL, IN, IS, JP, KE, KG, KM, KP, KR, KZ, LC, LK, LR, LS, LT, LU, LV, MA, MD, MG, MK, MN, MW, MX, MZ, NA, NI, NO, NZ, OM, PG, PH, PL, PT, RO, RU, SC, SD, SE, SG, SK, SL, SM, SY, TJ, TM, TN, TR, TT, TZ, UA, UG, UZ, VC, VN, YU, ZA, ZM, ZW, ARIPO patent (BW, GH, GM, KE, LS, MW, MZ, NA, SD, SL, SZ, TZ, UG, ZM, ZW), Eurasian patent (AM, AZ, BY, KG, KZ, MD, RU, TJ, TM), European patent (AT, BE, BG, CH, CY, CZ, DE, DK, EE, ES, FI, FR, GB, GR, HU, IE, IS, IT, LT, LU, MC, NL, PL, PT, RO, SE, SI, SK, TR), OAPI patent (BF, BJ, CF, CG, CI, CM, GA, GN, GQ, GW, ML, MR, NE, SN, TD, TG)

Published:

— with international search report
 — before the expiration of the time limit for amending the claims and to be republished in the event of receipt of amendments

For two-letter codes and other abbreviations, refer to the "Guidance Notes on Codes and Abbreviations" appearing at the beginning of each regular issue of the PCT Gazette.

ABLATION DEVICES WITH SENSOR STRUCTURES

CROSS-REFERENCE TO RELATED APPLICATIONS

The present application claims the benefit of the filing date of U.S. Provisional Patent Application No. 60/563,581, filed 5 April 19, 2004, the disclosure of which is hereby incorporated herein by reference.

BACKGROUND ART

The present invention relates to apparatus and methods for cardiac ablation and to sensor structures useful in such apparatus 10 and methods.

Contraction or "beating" of the heart is controlled by electrical impulses generated at nodes within the heart and transmitted along conductive pathways extending within the wall of the heart. Certain diseases of the heart known as cardiac 15 arrhythmias involve abnormal generation or conduction of the electrical impulses. One such arrhythmia is atrial fibrillation or "AF." Certain cardiac arrhythmias can be treated by deliberately damaging the tissue along a path crossing a route of abnormal conduction, either by surgically cutting the tissue or by 20 applying energy or chemicals to the tissue, so as to form scar. The scar blocks the abnormal conduction. For example, in treatment of AF, it has been proposed to ablate tissue in a partial or complete loop around a pulmonary vein within the vein itself, within the ostium or opening connecting the vein to the 25 heart, or within the wall of the heart surrounding the ostium. It would be desirable to perform such ablation using a catheter-based device which can be advanced into the heart through the patient's circulatory system.

As described in co-pending, commonly assigned U.S. Patent 30 6,635,054, the disclosure of which is incorporated by reference herein, an expansible structure is used as a reflector for directing and focusing ultrasonic waves from an ultrasonic transducer into a region of tissue to be ablated. As further described in the '054 patent, certain preferred embodiments 35 according to that disclosure include an expansible structure

incorporating a structural balloon which is inflated with a liquid and a reflector balloon inflated with a gas. The balloons share a common wall. The balloons are configured so that the common wall has a generally parabolic shape. Because the liquid in the structural balloon and the gas in the reflector balloon have substantially different acoustic impedances, the interface between the balloons at the common wall is a nearly perfect reflector for ultrasonic waves. Ultrasonic waves are emitted from a small transducer within the structural balloon and passes radially outwardly from the emitter to the reflector. The reflector redirects the ultrasonic waves and focuses it into a ring-like ablation region encircling the central axis of the emitter and balloons. This ablation region is just forward of the structural balloon. Thus, the ultrasonic waves will ablate tissue in a region encircling the central axis or forward-to-rearward axis of the balloon structure.

This arrangement can be used, for example, to treat atrial fibrillation by ablating a circular region of myocardial tissue encircling the ostium of a pulmonary vein. The ablated tissue forms a barrier to abnormal electrical impulses which can be transmitted along the pulmonary veins and, thus, isolates the myocardial tissue of the atrium from the abnormal impulses. To provide effective treatment in this mode of operation, the ring-like focal region should encircle the ostium and should lie in a plane which is parallel or nearly parallel with the inner surface of the heart. In some embodiments disclosed in the '054 patent, the structural balloon is provided with a forwardly projecting tip at its central or forward-to-rearward axis.

As disclosed in commonly assigned U.S. Provisional Patent Application Serial No. 60/448,804, filed February 20, 2003, and in commonly assigned, co-pending U.S. Published Patent Application No. 2004/0176757 (hereinafter "the '757 application") and PCT International Application No. PCT/US04/05197, the disclosures of which are incorporated by reference herein, a catheter-carried expansible ablation structure as disclosed in the '054 patent can

be equipped with a steering mechanism so that the orientation of the expansible structure relative to the heart can be controlled by the physician without relying upon physical engagement with the pulmonary vein or pulmonary vein ostium. This allows the apparatus to be positioned with the loop-like region lying in a plane substantially parallel to the heart wall in the region to be ablated, regardless of the orientation of the pulmonary veins relative to the heart wall and regardless of the exact anatomy of the pulmonary vein ostium in the particular patient to be treated.

As also disclosed in the '757 application, the catheter and the expansible structure desirably define a continuous passageway extending from the proximal end of the catheter to the distal or forward side of the expansible structure, and communicating with a port open on the distal side of the expansible structure. A contrast medium can be injected through this port while the device is in its expanded condition. This allows the physician to obtain an image of the expansible structure along with the heart and pulmonary veins before or during application of ultrasonic energy, so as to confirm proper placement of the device to form a lesion in the desired location. Further, the steering arrangement allows the physician to reposition the device so as to form multiple lesions. The lesions formed may include both loop-like lesions surrounding a pulmonary vein ostium and substantially linear lesions formed by placing the plane of the loop-like ablation region at a substantial angle to the plane of the heart wall, so that ablation occurs only along a small sector of the loop-like ablation region.

It is often desirable to monitor electrical signals propagating within the heart. For example, *McGee et al.*, U.S. Patent 5,860,920, discloses a structure incorporating an elongated element with numerous electrodes disposed along a distal region of the structure. The structure is advanced into the heart within a guide tube or sheath, which is then retracted so as to expose the distal region. In this condition, the distal region, under its

own resilience, forms itself into a hoop shape, which can be pressed into engagement with a region of the heart wall as, for example, a region surrounding the bicuspid valve or the mitral valve. The electrodes pick up electrical signals propagating within the heart. The electrodes can be connected to a source of electrical energy, so that the electrical energy applied through the electrodes ablates the cardiac tissue. *Swanson et al.*, U.S. Patent 5,582,609, discloses another loop-forming structure carrying electrodes for electrical ablation. *Fuimaono et al.*, U.S. Patent 6,628,976, discloses a catheter with a similar loop-like structure said to be useful in mapping electrical activity or "wavelets" within a pulmonary vein, coronary sinus or other "tubular structure" prior to treatment of the condition.

Marcus et al., U.S. Patent 5,295,484, discloses a catheter carrying both an ultrasonic transducer and electrodes for sensing electrical potentials within the heart. These electrodes can be used to allow the physician to determine whether the arrhythmia has persisted after the ablation process. Also, the aforementioned '054 patent and '054 patent disclose, in certain embodiments, expansible balloon structures having ring-like electrodes thereon for detecting electrical signals within the heart.

Despite all of these efforts in the art, however, still further improvement would be desirable. Providing electrical sensing structures on a balloon-like or other expansible ablation device complicates fabrication of the device and makes it more difficult to make the device collapse to a small diameter for advancing or withdrawing the device through the vascular system. Further, mounting the electrodes on the same catheter as an ultrasonic transducer, as disclosed in the '484 patent, limits placement of the electrodes and the configuration of the transducer array and associated structures. The particular structures shown in the '484 patent, for example, are not well suited to formation of a ring-like lesion or sensing of electrical potentials at numerous locations. Use of a loop-forming sensing

element entirely divorced from an ablation device, as contemplated in U.S. Patent 6,628,976, necessarily requires separate steps for placement of such a device which adds both complexity and risk to the procedure.

5 SUMMARY OF THE INVENTION

One aspect of the present invention provides apparatus for cardiac treatment which includes a catheter having proximal and distal ends and a lumen, as well as an expansible ablation device mounted at or near the distal end of the catheter. The ablation
10 device has a collapsed condition and an expanded condition, and is operative to apply energy to cardiac tissues in proximity to the device when the device is in the expanded condition. In its expanded condition, the device and catheter define a port open to the exterior of the expansible ablation device on the distal side
15 of the device. Desirably, the ablation device defines a bore extending through the ablation device. The bore has a first end communicating with the lumen and a second end defining the port.

Apparatus according to this aspect of the invention desirably also includes an elongated sensor probe which also has proximal
20 and distal ends. The sensor probe includes one or more electrodes disposed adjacent the distal end of the sensor probe. The lumen and the ablation device are constructed and arranged so that the sensor probe can be removably positioned in the passageway, with the distal end of the sensor probe projecting out of the ablation
25 device through the port.

The ablation device may be arranged to direct energy into a loop-like ablation region which encircles the port. Most preferably, the expansible ablation device includes an ultrasonic emitter and an expansible energy-directing structure, such as a
30 balloon structure, adapted to direct ultrasonic energy from the emitter into the loop-like region when the expansible ablation device is in its expanded condition.

The expansible inflation device desirably defines a forward-to-rearward axis, and the loop-like ablation region has an
35 axis substantially coaxial with this forward-to-rearward axis.

Desirably, the port is disposed on or adjacent to the forward-to-rearward axis of the ablation device, and the sensor probe includes a distal region carrying the electrode or electrodes. The distal region projects from the port when the sensor probe is positioned in the lumen of the catheter and the bore of the ablation device. Desirably, the sensor probe is constructed and arranged so that the distal region tends to form a hoop when the distal region projects from the port. The hoop desirably encircles the forward-to-rearward axis, and may be substantially coaxial with the forward-to-rearward axis and with the loop-like ablation region.

As further discussed below, apparatus according to this aspect of the invention allows the physician to position the expansible ablation structure as desired as, for example, to form a ring-like lesion. However, once the ablation device has been positioned, the sensor probe can be introduced readily through the passageway and is automatically aligned with the area to be ablated. For example, where the apparatus is used to form a ring-like lesion around a pulmonary vein or pulmonary vein ostium, the sensor probe will automatically be placed in alignment with the lesion and in alignment with the pulmonary vein and pulmonary vein ostium when it is introduced through the lumen and bore. Depending upon the radius of the hoop formed by the sensor, the hoop may be disposed inside the lesion to monitor electrical activity within the area enclosed or to be enclosed by the lesion. Alternatively, where the radius of the hoop formed by the sensing probe exceeds the radius of the ablation region, the hoop will lie outside of the ablation region, and will monitor electrical activity in this region.

The removable sensor probe does not impede other procedures such as introduction of a contrast medium through the passageway during positioning. The sensor probe can be placed at any time during the procedure to monitor electrical activity before or after ablation, or even during ablation. Because the catheter and ablation device serve as an introducer structure for the sensor

probe, the sensor probe can be introduced readily, without interrupting the procedure. Moreover, because the sensor probe is removable, the apparatus may include more than one sensor probe, which may have different configurations and different sizes, so that the sensing electrodes can be placed at different locations.

A further aspect of the invention provides methods of cardiac ablation which include the steps of advancing an apparatus including a catheter and an expansible ablation device into the subject while the ablation device is in a collapsed condition, until the ablation device is disposed in a chamber of the subject heart, and then expanding the ablation device to an expanded condition. In a method according to this aspect of the invention, the ablation device desirably is positioned in a desired disposition relative to the heart and actuated to apply energy in a loop-like region having a predetermined spatial relationship to the ablation device, and thereby ablate the tissue in this region so as to form a lesion. Methods according to the invention desirably further include the step of advancing a sensing probe through a continuous passageway from the proximal end of the catheter through the ablation device, so that a distal region of the sensing probe projects out of a port on the ablation device and contacts tissue of the subject adjacent the ablation device. In methods according to this aspect of the invention, the ablation device desirably at least partially positions the projecting distal region of the sensing probe relative to the heart. The method desirably further includes the step of detecting electrical signals in the subject using the sensing probe. Methods according to this aspect of the invention afford advantages similar to those discussed above in connection with the apparatus.

Yet another aspect of the invention provides a probe which includes a probe body having an undeployed condition and a deployed condition, and one or more functional elements such as electrodes carried on the probe body. The probe body, in its undeployed condition, desirably is elongated and flexible, and desirably includes a distal region carrying the functional

elements. In its deployed condition, the probe body includes a base portion extending in a distal direction, and a limb extending from the distal end of the base portion in a radial direction transverse to the distal direction. The limb also extends in a proximal direction opposite to the distal direction. The limb has an outer end remote from the base portion. In the deployed condition, the probe body desirably also forms a hoop extending from the outer end of the limb, at least partially around the base portion. The hoop desirably carries one or more of the functional elements.

A probe according to this aspect of the invention desirably is used in combination with an introducer structure having proximal and distal ends and a port adjacent the distal end of the introducer structure, as well as a passageway extending from adjacent the proximal end to the port. The probe body in its undeployed condition desirably is slideable in the passageway. In the deployed condition, the base portion of the probe body extends in the passageway and projects from the port. The introducer structure may include a catheter and an expansible ablation device as discussed above. The ablation device, in its expanded condition, may define a distal wall, and the port may be disposed on or forward of the distal wall. The ablation device may have a projection extending forwardly from the distal wall when the ablation device is in the expanded condition, and the port may be disposed on this projection. When the sensor probe is in its deployed condition, the base portion projects out of the port forward of the distal wall, whereas the limb portion extends rearwardly towards the distal wall, and the hoop region overlies the distal wall and extends around the projection. Stated another way, in the deployed condition, the sensor probe extends out of the port and rearwardly towards the distal wall, so as to place the hoop region in proximity to or abutting the distal wall of the ablation device. Desirably, the probe body is a self-deploying resilient structure which is arranged to form the configuration including the limb and hoop region spontaneously, under the

influence of its own resilience, as the distal end of the probe body is advanced outwardly through the port.

These and other objects, features and advantages of the present invention will be more readily apparent from the detailed
5 description of the preferred embodiments set forth below, taken in conjunction with the accompanying drawings.

BRIEF DESCRIPTION OF THE DRAWINGS

FIG. 1 is a diagrammatic, partial sectional view of apparatus in accordance with one embodiment of the invention during one
10 stage of a method in accordance with an embodiment of the invention.

FIG. 2 is a fragmentary, diagrammatic perspective view depicting components of the apparatus shown in FIG. 1 at another stage in the method.

15 FIG. 3 is a diagrammatic sectional view taken along line 3-3 in FIG. 2.

FIG. 4 is a diagrammatic perspective view of the components illustrated in FIG. 2 during another stage in the method.

20 FIG. 5 is a fragmentary, diagrammatic elevational view depicting a portion of apparatus in accordance with another embodiment of the invention.

FIG. 6 is a diagrammatic perspective view depicting a component of the apparatus shown in FIG. 5.

25 FIGS. 7-14 are schematic perspective views depicting portions of the apparatus shown in FIGS. 5 and 6 during successive stages of operation.

FIG. 15 is a diagrammatic elevational view of a probe in accordance with a further embodiment of the invention.

30 FIG. 16 is a fragmentary diagrammatic sectional view depicting a portion of the probe shown in FIG. 15.

FIG. 17 is a fragmentary diagrammatic sectional view depicting a further portion of the probe shown in FIG. 15.

FIG. 18 is a diagrammatic perspective view depicting a portion of the probe shown in FIG. 15.

35 BEST MODE FOR CARRYING OUT INVENTION

10

As seen in FIG. 1, apparatus according to one embodiment of the invention includes an insertable structure 10 incorporating an elongated catheter 12 having a proximal end 14, which remains outside of the body, and a distal end 16 adapted for insertion into the body of the subject. As used in this disclosure with reference to structures which are advanced into the body of a subject, the "distal" end of such a structure should be taken as the end which is inserted first into the body and which penetrates to the greatest depth within the body, whereas the proximal end is the end of the structure opposite to the distal end. The insertable structure 10 also includes an ablation unit 18 mounted to the catheter adjacent distal end 16. Ablation unit 18 incorporates a reflector balloon 20 and a structural balloon 22 having a common wall 24. Reflector balloon 20 is linked to an inflation lumen (not shown) in catheter 10, which extends to the proximal end of the catheter and which is connected, during use, to a source of a gas under pressure, such as air or, more preferably, carbon dioxide, as, for example, to a gas-filled hypodermic syringe, so that the reflector balloon can be inflated with a gas. Structural balloon 22 is connected through a separate inflation lumen (not shown) to a source of a liquid such as isotonic saline solution, so that structural balloon 22 can be inflated with the liquid. A cylindrical ultrasonic emitter 23 is mounted within the structural balloon. Balloons 20 and 22, and particularly the common wall 24 separating the balloons, are designed so that in their inflated, operative condition illustrated in FIG. 1, the balloons are in the form of bodies of revolution about a central or forward-to-rearward axis 26. Emitter 23 is cylindrical and is coaxial with the balloons.

A tube defining a bore 28 extends through the structural balloon at the central axis 26. Tube bore 28 communicates with a port 29 on or forward of the forward wall 38 of the structural balloon. Tube bore 28 also communicates with a lumen 30 within catheter 12. Lumen 30 extends to the proximal end 14 of the catheter and is provided with a suitable fluid connection such as

a Luer hub. Tube bore 28 and lumen 30 together form a continuous passageway extending from the outlet port 29, just distal to the ablation device back to the proximal end 14 of the catheter. As further described in co-pending, commonly assigned U.S. Patent Application Serial No. 10/244,271, filed September 16, 2002, now U.S. Patent 6,808,524 ("the '524 patent"), the disclosure of which is incorporated by reference herein, tube 28 may be formed from a material such as an expanded polymer of the type commonly used in vascular grafts, so that the interior bore of the tube remains patent when the tube is stretched.

As also disclosed in the '524 patent, a coil spring 34 may be provided within the structural balloon, such that the coil spring surrounds tube 28. A reinforcing structure which may include one or more rigid tubes of metal or a rigid polymer such as polyether ether ketone ("PEEK") 36 extends coaxially with the tube defining bore 28 and spring 34. In the particular embodiment shown in FIG. 1, the rigid tubular structure 36 is disposed outside of tube spring 34; in other embodiments, the rigid tube or tubes can be disposed within spring 34, inside or outside of tube 28, so that the rigid tube or tubes define a portion of the bore. As described in greater detail in the '524 patent and in the aforementioned '757 application, the spring is compressed when the balloons are in the inflated, expanded state. When the balloons are deflated, the spring expands and moves the forward wall 38 of the structural balloon in the forward or distal direction F (up and to the left, as seen in FIG. 1) relative to the rearward or proximal end of the balloon and relative to the catheter 12, thereby collapsing the balloon in a radial direction, and also twists the balloons about axis 26 to facilitate radial collapse and formation of a small, radially compact unit for withdrawal from the patient. However, when the balloons are inflated, the spring is compressed and reinforcing element 36 engages a rigid mounting 40 attached to the distal end 16 of the catheter, which mounting also holds ultrasonic emitter 23. This assures that the axis 26 of the balloon structure is precisely aligned with the

axis of the emitter and reinforces the balloon against deflection transverse to the axis 26.

In the arrangement depicted in FIG. 1, the tubular reinforcing element 36 abuts the distal end of the mounting 40. In a variant, the mounting is telescopically received within the tubular reinforcing element. Thus, as the balloons are inflated, the tubular reinforcing element 36 moves proximally or rearwardly so that the distal end of the mounting 40 enters into the tubular reinforcing element before the balloons are fully inflated. In the fully-inflated condition, the tubular reinforcing element remains slightly distal or forward of the transducer 23 or else abuts the distal end of the transducer. Engagement between the mounting and the reinforcing element helps prevent kinking or displacement of the structure transverse to axis 26 when the structure is in a partially-inflated or fully-inflated condition.

The common wall 24 separating the balloons forms an active, reflective interface. This active interface desirably has the form of a surface of revolution of a parabolic section around the central axis 26. When the balloons are in their inflated, expanded configuration shown in FIG. 1, ultrasonic waves emitted by emitter 23 are directed radially outwardly away from axis 26 and impinge on the parabolic active interface 24, where it is reflected forwardly and slightly outwardly away from axis 26 and focused so that the ultrasonic waves emitted along various paths mutually reinforces within a ring-like ablation region A, just forward of the forward wall 38 of the structural balloon encircling axis 26. The focused ultrasonic waves in this region can effectively ablate myocardial tissue and form a substantial conduction block extending through the heart wall in a relatively short time, typically about a minute or less.

Catheter 10 includes a bendable section 60. A steering mechanism is provided for selectively bending section 60 so as to orient the ablation device 18 and the forward-to-rearward axis 26 of the ablation device. In the particular embodiment depicted, the steering mechanism includes a pull wire 62 extending through a

lumen 64, a portion of which is shown in FIG. 1. The pull wire has a distal end 66 affixed to the distal end 16 of the catheter, or to the ablation device itself. The proximal end 68 of the pull wire is connected to a handle or other appropriate device for manipulating the pull wire relative to the catheter. One particularly useful arrangement of the pull wire is further described in the aforementioned '757 application. By manipulating the pull wire, the bendable section 60 can be bent to a greater degree, or can be allowed to straighten. Also, the catheter structure desirably is "torqueable," so that rotation applied to the catheter structure about its own axis at the proximal end is transmitted through the catheter to the distal end. Thus, the bendable section 60 can be rotated so as to change the orientation of the bendable section and, thus, the orientation of axis 26. The pull wire arrangement is merely exemplary of the numerous structures which can be used to provide steerability to the catheter.

The apparatus further includes an elongated sensor probe 72 having a proximal end 74 and a distal end 76. The probe includes an elongated resilient body 78 having a diameter smaller than the inside diameter of lumen 30. A plurality of electrodes 80 (FIGS. 2 and 4) extend around the probe body in an operative region 82 adjacent the distal end of the probe, also referred to as a "hoop region." The probe body also includes a juncture region 84 disposed proximal to the operative region and a main or base region 86 extending from the juncture region to the proximal end 74 of the probe. A connector 88 is provided at the proximal end of the probe. As best seen in FIG. 3, the probe body 78 includes a dielectric layer 90 and conductors 92 extending within the dielectric layer from electrodes 80 to connector 88 (FIG. 2). The probe body also includes a resilient metallic element 94 extending along the length of the probe body. Element 94 may be a super elastic material such as an alloy of nickel and titanium, commonly referred as nitinol. The particular arrangement depicted in FIG. 3, with conductors 92 disposed around resilient element 94, is not

essential. For example, the conductors may be grouped to one side of the elastic element. Probe 72 can be placed into the continuous passageway defined by the catheter lumen 30 and bore 28, and can be removed therefrom.

5 In its free or unconstrained condition, probe body 78 assumes the shape depicted in FIG. 4. In this shape, hoop region 82 forms a generally circular hoop 82 in a plane transverse to the axis 96 defined by the distal-most part of main portion 86. The hoop encircles axis 96 and is substantially coaxial therewith. The
10 connecting or transition region 84 extends outwardly from axis 96 and also slopes slightly in the forward or distal direction. As discussed below, the probe body is in this unconstrained state when deployed within the heart, and accordingly, this condition is also referred to herein as the "deployed" condition of the probe
15 body.

In a method according to one aspect of the present invention, the ablation device 18 is positioned within a chamber of the heart as, for example, within the left atrium LA of a subject to be treated. A guide sheath (not shown) is advanced through the
20 venous system into the right atrium and through the septum separating the right atrium and left atrium, so that the guide sheath provides access to the left atrium. Typically, the apparatus is advanced through the guide sheath with the balloons in a deflated, collapsed condition. This operation may be
25 performed by first advancing a guide wire (not shown) into the heart, and then advancing the insertable structure 10, with the balloons in a deflated condition, over the guide wire. During this operation, probe 78 is not present in tube bore 28 and lumen 30. The guide wire passes through tube bore 28 and through
30 lumen 30. A guide sheath also may be used during the insertion process.

When the ablation device 18 is disposed inside the heart chamber, the physician manipulates the device using steering mechanism 70 (FIG. 1) to vary the orientation of the ablation
35 device, and hence the orientation of forward-to-rearward axis 26,

until the device is positioned in the desired spatial relationship to the heart, with the axis 26 extending generally normal to the surface of the heart surrounding the ostium OS of a pulmonary vein PV.

5 As discussed in greater detail in the '757 application, the physician may verify the proper disposition of the ablation device relative to the heart by injecting a fluid contrast medium through the continuous passageway defined by lumen 30 and tube bore 28 and out through port 29 on the distal or forward side of the ablation
10 device. Depending upon the pressure with which the contrast medium is injected, some portion of the contrast medium may pass into the pulmonary vein and other portions may remain within the left atrium. While the contrast medium is present, the subject is imaged using an imaging modality which will show the contrast
15 medium as, for example, conventional x-ray or fluoroscopic imaging.

With the ablation apparatus properly positioned for ablation, the physician may actuate ultrasonic emitter 23, as by actuating an electrical energy source (not shown) connected to the emitter
20 23 by conductors in catheter 30 (also not shown). The ultrasonic emitter directs ultrasonic energy onto the wall 24 between balloons 20 and 22, where the energy is reflected in a forward direction F and focused into the ring-like ablation region A. The focused ultrasonic energy heats and ablates the myocardial tissue
25 in this region, thereby converting this tissue into scar tissue which is not capable of conducting electrical impulses.

The physician may detect electrical signals within the pulmonary vein or pulmonary vein ostium by inserting probe 78 into the subject through the continuous passageway defined by lumen 30
30 and tube bore 28. The physician manually straightens the hoop region 82 and transition portion 84 as these are inserted through the proximal end of the catheter. The probe body has sufficient flexibility so that it can be advanced distally through the passageway. As the probe body advances through the catheter, the
35 curvature of the probe body conforms to the existing curvature of

the catheter. As the probe body continues to advance, it reaches the condition shown in FIG. 2. In this undeployed condition, the hoop region 82, transition region 84 and main region 86 are disposed in the continuous passageway, with the distal end 76 of the probe body proximal to port 29. As the physician continues to advance the sensor probe, the distal end 76, hoop region 82 and transition region 84 pass distally out of port 26, whereupon the hoop region and transition region spring back to their unconstrained or deployed shape, as depicted in FIG. 4. This places the hoop 82 concentric with the axis 96 defined by main portion 86 of the probe body. However, because the main portion 86 is disposed within the tube bore 28 of the ablation device, the main portion 86 is coaxial with the axis 26 of the ablation device. Thus, hoop 82 tends to deploy in a plane perpendicular to axis 26 of the ablation device, with the hoop concentric with the same axis. As mentioned above, during placement of ablation device 18, the physician has already positioned this axis in alignment with the pulmonary vein ostium and has positioned this axis generally normal to the plane of the heart tissue encircling the ostium. Thus, the hoop tends to deploy in a location as shown in FIG. 1, with the hoop lodged within the pulmonary vein ostium, or (depending upon the diameter of the pulmonary vein) in the pulmonary vein itself, and with the hoop 82 lying in the plane transverse to the axis of the pulmonary vein and the axis of the pulmonary vein ostium. All of this is accomplished without substantial manipulation by the physician to aim or locate the hoop. Stated another way, the ablation device 18 and catheter 12 act as an introducer structure which directs the distal portion of the sensor probe into alignment with the pulmonary vein ostium. Thus, placement of the sensor probe can be accomplished readily.

Although the catheter and ablation device act to introduce and aim the hoop region of the sensor, the hoop region is not rigidly mounted to the ablation device or catheter, and hence, is not rigidly positioned by these devices. Transition region 84 has some flexibility, so that the hoop 82 can be displaced or tilted

somewhat from perfect coaxial alignment with the ablation device. This allows the hoop region to engage the tissues substantially around the pulmonary vein or ostium, even where these anatomical features are not perfectly aligned with the axis of the ablation device. Also, hoop 82 has some flexibility, and accordingly can conform to these structures, even where the same are not perfectly circular.

With the hoop 82 engaged with the tissues, electrodes 80 on the hoop will also be engaged with the tissues and hence will receive electrical signals propagating within the tissues. The physician can monitor these electrical signals using a conventional signal detection system 99 connected to connector 88 and hence connected to the electrodes through the conductors 92 (FIG. 3) of the sensor probe. If these electrical signals indicate that abnormal conduction is continuing to occur, the physician can actuate the ablation device again. The sensing probe need not be removed from the device during such further ablation. Alternatively, the sensing probe may be removed and other procedures, such as injection of additional contrast medium to confirm the desired disposition of the ablation device, may be performed. In a further variant, the sensor probe may be introduced and placed as described above before actuation of the ablation device, most typically after correct placement of the ablation device has been confirmed, as by use of the contrast medium technique discussed above.

In a further variant, the ablation device 18 can be repositioned to a new position as partially depicted in broken lines at 18' in FIG. 1. The sensor probe may be retracted into the catheter and ablation device, or may be entirely removed during the repositioning step. The same steps as discussed above may be repeated. The ability to retract or entirely remove the sensor probe facilitates repositioning. For example, contrast medium may be injected again to confirm the moved position of the apparatus. Also, because the sensor probe does not project from

the apparatus during the repositioning step, it does not interfere with repositioning.

Apparatus according to a further embodiment of the invention (FIG. 5) includes a catheter 112 and ablation device 118 generally similar to the corresponding components discussed above with reference to FIG. 1. Here again, the ablation device 118 incorporates an expansible balloon structure incorporating a reflector balloon 120 and a structural balloon 122. Here again, the structural balloon defines a forward or distal surface 138, and the ablation device incorporates an emitter 123 arranged to supply ultrasonic energy which is reflected by the interface between balloons through the front or distal wall 138 of the expandable inflation device into a ring-like focal or ablation region A surrounding the forward-to-rearward axis 126 of the ablation device. In this embodiment, the ablation device includes a projection 139 extending forwardly from forward surface 138, such projection being generally in the form of a surface of revolution about axis 126. The port 129 at the forward end of the ablation device is disposed on projection 139. In the particular structure depicted in FIG. 5, projection 139 includes an inflated section of structural balloon 122 and a section at the distal end of the inflated section. A metallic fitting 141 is disposed inside of this section of the balloon, the balloon being cemented to the fitting. The fitting defines port 129. The fitting may cooperate with a spring (not shown) and with the reinforcing elements to provide the spring-back collapsing and twisting action as discussed above during collapse of the balloon, and to provide the reinforcement against displacement transverse to the axis, as discussed above. Here again, catheter 112 and ablation device 118 cooperatively define a continuous passageway, including a lumen 130 of catheter 112 and the bore 128 extending through the ablation device to port 129.

The apparatus includes a sensor probe 172 which can be inserted into or removed from the continuous passageway. The probe incorporates a self-deploying probe body 178 depicted in its

deployed condition in FIGS. 5 and 6. The probe body includes a base or main portion 186 and a hoop region 182 which, in the deployed condition, forms a substantially closed, circular hoop. The probe body also includes a limb portion 184 extending from the distal end of the main portion to the hoop region. As in the embodiments discussed above, the probe 172 has electrodes 180 disposed on the hoop region. The probe body 178 also includes leads, a dielectric and a resilient structure which may be similar to those discussed above, the leads serving to connect the electrodes 180 with a connector (not shown) at or adjacent the proximal end of the probe.

In the embodiment of FIGS. 5 and 6, the limb portion 184 extends outwardly from the main portion and also extends rearwardly or proximally from the distal end of the main portion, so that the hoop region 182 is disposed to the rear of the distal end 187 of the main portion. In the deployed condition, hoop region 182 encircles the base or main portion 186. When the probe is in its deployed condition and completely unconstrained, hoop region 182 lies generally in a plane transverse to the axis of main or base portion 186, but has a slight curvature in the distal direction, *i.e.*, towards the distal end of the main portion 186. Stated another way, the tip 183 of the hoop region furthest from limb portion 184, as measured by distance traveled along the length of the hoop region, lies closer to the distal end 187 than the juncture 185 of the hoop region and limb portion. The hoop region is quite flexible in the axial direction, so that tip 183 can be displaced axially and the hoop region may be flattened into a planar structure with only minimal force applied to tip 183 in the axial direction.

As in the embodiments above, the probe body is advanced by straightening it and sliding it through the continuous passageway defined by the lumen 130 of the catheter and the bore 128 of the ablation device. Here again, in an undeployed condition, the hoop region 182, limb 184 and base or main portion 186 are disposed within the passageway and hence conform to the curvature of the

passageway. In the deployed condition (FIG. 5), the hoop region 182 encircles the axis 126 of the ablation device and encircles projection 139. The base portion 186 of the probe body is aligned with axis 126 and projects through port 129, whereas limb portion 184 extends radially outwardly from axis 126 and also extends rearwardly or proximally to the hoop region. Placement of the hoop region around projection 139 allows hoop region 182 to abut the forward surface 138 of the ablation device and allows the physician to urge the ablation device forwardly or distally so as to bring the hoop region into firm engagement with the tissues. This arrangement is particularly useful where the hoop region has a diameter larger than the diameter of the pulmonary vein, so that the hoop region is to be engaged with a portion of the heart wall which extends generally transverse to axis 126. For example, where ablation region A is of a diameter selected to ablated tissue surrounding the ostium, it may be desirable to engage hoop region 182 and electrode 180 with a part of the heart wall surrounding the ostium, rather than with tissue inside the ostium or in the pulmonary vein. The hoop region may be of larger diameter or smaller diameter than the ablation region A.

The sequence of operations used to deploy the sensor probe of FIGS. 5 and 6 is depicted schematically in FIGS. 7-14. In these figures, the introducing structure, including the catheter and ablation device shown in FIG. 5 are symbolized by a generalized body 101. Also, the description uses a coordinate system with mutually orthogonal X, Y and Z directions. This coordinate system is associated with the main portion 186 of the probe body. Rotation of the main portion of the probe body about its own axis and about the axis 126 defined by the ablation device has no effect on the operations discussed with reference to FIGS. 7-13. As the probe body is advanced out through port 129, the leading end of the probe body is that portion which will ultimately form the tip 183 of the hoop region discussed above with reference to FIGS. 6. This leading portion has a natural or unconstrained curvature relative to the next-trailing portion in a first or -X

radial direction, in the X-Z plane, and thus deflects toward the -X axis when the probe is first advanced out through the port 129, as depicted in FIG. 7. The next part of the probe, hoop region 182 has a free or unconstrained curvature in the Y-Z plane, orthogonal to the curvature of portion 183. Thus, as hoop region 182 is progressively advanced out of port 129 (FIGS. 8 and 9), it curves relative to structure 101 and relative to the trailing portions of the probe body in the Y-Z plane, and thus first swings the leading tip portion in the +-Y direction, away from axis 126 and introducer structure 101, so that the tip portion moves generally in the +-Y direction. However, as more of portion 182 is advanced out of the port, the curvature of the hoop region causes the tip portion 183 to move generally in the opposite, -Y direction (FIG. 10), back towards axis 126 and introducer structure 101, until the tip portion 183 engages the introducer structure 101.

Because the tip portion 183 is curved in the -X direction, it provides a "lead-in" so that as tip 183 is urged further in the -Y direction by the deploying hoop region 182, tip portion 183 will tend to slide on the introducer structure 101 in the -X direction. Thus, as the hoop region 182 is further deployed, it will reliably pass on the -X side of introducer structure 101 and axis 126, so that the structure reaches the condition depicted in FIG. 11, with the juncture 185 of the hoop region and limb portion emerging from port 129. In this condition, hoop region 182 has formed a ring or hoop, with a portion of the hoop opposite from juncture 185 and tip portion 183 disposed on the -X side of the introducer structure 101.

As the limb portion 184 emerges from port 129, the loop travels in the +Z direction (FIG. 12) until the juncture between limb portion 184 and base portion 186, at the distal end 187 of the base portion, begins to emerge from the port. The curvature of the juncture at the distal end 187 of the base portion swings the limb portion in an arc in the Y-Z plane, so that the juncture 185 of the limb portion and hoop region 182 first moves in the +X

direction and in the -Z or rearward direction. As the juncture 187 at the distal end of base portion 186 continues to emerge from the port, continued movement swings juncture 185 and hoop 182 in the -X direction, as well as in the -Z or rearward direction, as seen in FIG. 14. This action brings the hoop region 182 to the fully deployed condition depicted in FIGS. 5 and 6. During this final phase of deployment, portion 182 may or may not bear on a forwardly or distally-facing wall 105 of the introducer structure as, for example, wall 138 of the expandable ablation device seen in FIG. 5.

During deployment of the sensor probe discussed with reference to FIGS. 5-14, the expansible inflation device 118 may be temporarily retracted in the proximal or rearward direction relative to the wall of the heart, so as to provide clearance for movement of the hoop forward of the structure, as seen in FIGS. 12 and 13.

Numerous variations and combinations of the features discussed above can be utilized without departing from the present invention. Merely by way of example, it is not essential that the ablation device include the ultrasonic element and reflectors discussed above. For example, an expandable balloon having electrodes suitable for ablation or arrangements for delivering optical energy may be used. Also, the probe and method of probe deployment discussed above with reference to FIGS. 5-13 may be used for purposes other than sensing electrical signals in the context of an ablation process. For example, the probe can be used in a cardiac mapping operation, distinct from an ablation process. In a further variant, the functional elements of the probe (the sensing electrodes 180) may be used as ablation electrodes; or may be replaced by functional elements other than electrodes as, for example, discrete ultrasonic transducers or the like for an ablation process; or by sensors other than electrodes as, for example, chemical sensors. Further, although the present invention is particularly useful in performing procedures within the heart, it can be applied to performing procedures within other

internal organs of a human or animal subject, or indeed, to performing procedures within a cavity of an inanimate subject.

A sensor probe in accordance with a further embodiment of the invention has a composite body 200 (FIG. 15) including a tubular
5 metallic shaft section 202 which may be formed from a stainless steel tube of the type commonly used to form hypodermic needles. The shaft section defines interior bore 203 (FIG. 16). Desirably, the shaft section has an outside diameter D_s (FIG. 16) on the order of 1.25 mm or less, more desirably about 1 mm (0.040 inches) or
10 less, and most preferably about 0.9 mm (0.035 inches). Preferably, the shaft section 202 extends throughout the majority of the length of the probe 200. For example, the shaft section may be on the order of 140 cm (55 inches) long.

A distal section 206 is mounted to the distal end 204 of
15 shaft section 202. The distal section 206 includes a wire core 210 (FIG. 17) with a dielectric, biologically inert polymeric covering 212 overlying the core. The core desirably is formed from a metal such as a nickel-titanium alloy which can be formed to a preselected shape and which will tend to return to the
20 preselected shape when unconstrained. A plurality of electrodes 216 overlie the covering 212 in a portion of the length of the distal section. As best seen in FIGS. 15 and 18, this portion 208 of the distal section in its free or unconstrained condition forms a hoop lying in a plane transverse to the axis defined by the
25 remainder of the distal section. In the free or unconstrained condition, the distal section may extend about 5 cm (2 inches) proximally from the plane of the hoop. The distal section 206 is formed to this hoop shape and tends to return to this shape when the distal section is unconstrained. However, the distal section
30 is quite flexible, and hence, can be constrained to a straight or gently curving shape, so as to be advanced through the passageway defined by the catheter and ablation device as discussed above. Shaft section 202 is flexible enough to pass through gently curving portions of the catheter, but is considerably stiffer than
35 the distal section.

The proximal end of the distal section 206 abuts the distal end 204 of the shaft section and is bonded to the shaft section 202. Desirably, wire core 210 extends into the bore 203 of the shaft section a short distance from this abut joint. A plurality of fine insulated wires 220 are disposed within the bore 203 of the shaft section. These wires are electrically connected to electrodes 216 on the distal section. The probe body also includes a proximal section 222 and a transition section 224 extending from the proximal section to the proximal end 226 of the shaft portion. The proximal end section may include a relatively stiff polymeric tube having an interior bore (not shown). The transition section 224 may include a polymeric tube having stiffness intermediate between that of the proximal end section and the shaft section, this tube also having an interior bore. The interior bores of the transition section 224 and proximal section 222 may communicate with the bore of shaft section 202. Alternatively, the metallic tube forming shaft section 202 may extend through the interior bores of the transition section and the proximal section. In either arrangement, wires 220 may extend all the way to the proximal end of proximal end section 222. An electrical connector 230 is connected to these wires and, hence, to electrodes 216.

In use, the probe body according to this embodiment can be advanced and deployed as discussed above. The shaft portion 202 constituting the major portion of the probe length has a appreciable stiffness. Moreover, the shaft portion is smooth and slides readily within the structures defining the passageway. Therefore, the probe does not tend to buckle and jam as the probe is threaded through the passageway of the catheter. During threading, of course, the distal end portion is not in the hoop-shape shown, but instead is straight or slightly curved to match the curvature of the passageway in the catheter. Typically, the distal end portion 206 is substantially more flexible than the shaft portion 202. The joint between the distal end portion and the shaft portion (at the distal end 204 of the shaft portion)

most preferably lies just proximal to the bendable section 62 of the catheter when the probe is fully advanced.

As these and other variants can be employed, the foregoing description of the preferred embodiments should be taken by way of illustration rather than by way of limitation of the invention as 5 further set forth in the claims.

INDUSTRIAL APPLICABILITY

The present invention can be utilized in medical and veterinary treatment.

CLAIMS:

1. Apparatus for cardiac treatment comprising:

(a) a catheter having proximal and distal ends;

(b) an expansible ablation device including one or more
5 balloons mounted to said catheter at or adjacent the distal end
thereof, said ablation device having a collapsed condition and an
expanded condition, said balloon ablation device being operative
to ablate cardiac tissue in proximity to the ablation device when
the ablation device is in said expanded condition, said catheter
10 and said ablation device in said expanded condition defining a
defining a port open on the distal side of said one or more
balloons and a continuous passageway extending between said port
and the proximal end of the catheter, said catheter being
steerable so that the orientation of said expandable ablation
15 device relative to the heart can be selectively varied; and

(c) an elongated sensor probe having proximal and
distal ends, said sensor probe including one or more electrodes
disposed adjacent the distal end of the sensor probe, said lumen
and said ablation device being constructed and arranged so that
20 said sensor probe can be removably positioned in said passageway
with the distal end of said sensor probe projecting out of said
ablation device through said port.

2. Apparatus as claimed in claim 1 wherein said expansible
ablation device is constructed and arranged to direct energy into
25 a loop-like region encircling said port.

3. Apparatus as claimed in claim 2 wherein said expansible
ablation device includes an ultrasonic emitter and said one or
more balloons form an expansible energy-directing structure
adapted to direct ultrasonic energy from said emitter into said
30 loop-like region when said expansible ablation device is in said
expanded condition.

4. Apparatus as claimed in claim 3 wherein said one or more
balloons include a structural balloon and a reflector balloon
defining a common wall so that when said expandable structure is
35 in said expanded condition with said structural balloon inflated

with a liquid and said reflector balloon inflated with a gas, said balloons form an interface reflective to ultrasonic energy at said common wall.

5 5. Apparatus as claimed in claim 3 wherein said expansible ablation device defines a forward-to-rearward axis, said loop-like region having an axis substantially coaxial with said forward-to-rearward axis of said ablation device, said energy-directing structure being arranged to direct said ultrasonic energy into said region in a direction having a forward component.

10 6. Apparatus as claimed in claim 3 wherein said port is disposed on said forward-to-rearward axis and wherein said sensor probe includes a distal region carrying said one or more electrodes, said distal region projecting from said port when said sensor probe is positioned in said passageway, said sensor probe
15 being constructed and arranged so that said distal region tends to form a hoop coaxial with said forward-to-rearward axis and said loop-like region when said distal region projects from said port.

20 7. Apparatus as claimed in claim 2 wherein one of said balloons of said expansible ablation device includes a distal wall, said loop-like region overlying said distal wall in said expanded condition, said port being disposed on said distal wall.

25 8. Apparatus as claimed in claim 7 wherein said sensor probe includes a distal region carrying said one or more electrodes, said distal region projecting from said port when said sensor probe is positioned in said passageway, said sensor probe being constructed and arranged so that said distal region tends to form a hoop when said distal region projects from said port.

30 9. Apparatus as claimed in claim 8 wherein said hoop is substantially coaxial with said loop-like region.

 10. Apparatus as claimed in claim 8 wherein said hoop is disposed distal to said port.

 11. Apparatus as claimed in claim 8 wherein said hoop closely overlies said distal wall.

35 12. Apparatus as claimed in claim 11 wherein said distal wall includes a main portion and a tip portion projecting distally

from said main portion, said port being disposed on said tip portion, said hoop closely overlying said main portion so that said hoop is disposed proximal to said port.

13. Apparatus as claimed in claim 1 wherein said catheter
5 includes a bendable section adjacent the distal end of the catheter but proximal to the ablation device.

14. Apparatus as claimed in claim 13 further comprising one or more pull wires, each said pull wire having a distal end connected to the catheter distal to said bendable section or to
10 said ablation device, said one or more pull wires being slidably mounted to the catheter so that the bendable section can be selectively bent by pulling one or more of said pull wires.

15. Apparatus as claimed in claim 1 wherein said sensor probe includes a tubular metallic shaft section and a distal
15 section connected to the distal end of said shaft section, said distal section including one or more electrodes, said sensor probe further including one or more conductors electrically connected to said one or more electrodes, portions of said conductors extending within said shaft section.

20 16. Apparatus as claimed in claim 15 wherein said distal end section includes a wire core, a polymeric covering overlying said wire core, said one or more electrodes overlying said polymeric covering so that said covering insulates at least some of said electrodes from said core.

25 17. A sensor probe comprising:

(a) an elongated tubular metallic shaft section having proximal and distal ends;

(b) a elongated distal section having proximal and distal ends including a metallic wire core and a polymeric
30 covering overlying said wire core, one or more electrodes overlying said polymeric covering, said distal section having an unconstrained shape including a hoop including at least a part of said distal section having said one or more electrodes thereon;
and

(c) one or more electrical conductors extending within said shaft section, said electrical conductors being electrically connected to said electrodes.

18. A probe as claimed in claim 17 wherein said shaft section and said distal sections have cross-sectional dimensions of about 1.25 mm or less.

19. A probe as claimed in claim 18 wherein said one or more electrodes include a plurality of electrodes.

20. A probe as claimed in claim 17 wherein said distal section is substantially more flexible than said shaft section.

21. A method of cardiac ablation comprising the steps of:

(a) advancing apparatus including a catheter and an expansible ablation device incorporating one or more balloons into a subject while said so that said ablation device is in a collapsed condition until the ablation device is disposed in a chamber of the subject's heart;

(b) expanding the ablation device to an expanded condition by inflating said one or more balloons;

(c) while said ablation device is in said expanded condition, positioning the ablation device in a desired disposition relative to the heart by selectively steering said catheter so as to bring the ablation structure to a desired orientation relative to the heart;

(d) actuating the ablation device to apply energy in a loop-like region in a predetermined spatial relationship to said ablation device and thereby ablate tissue in said region to form a lesion;

(e) while said ablation device is in said expanded condition, advancing a sensing probe through a passageway in said catheter and said ablation device so that a distal region of said sensing probe projects out of a port on said ablation device and contacts tissue of the subject adjacent said ablation device and said ablation device at least partially positions the projecting distal region relative to the heart; and

(f) detecting electrical signals in the subject using said sensing probe.

22. The method as claimed in claim 21 wherein said steps of advancing the sensing probe and detecting electrical signals are performed after said step of actuating said ablation device.

23. The method as claimed in claim 21 wherein said steps of advancing the sensing probe and detecting electrical signals are performed a first time before said step of actuating said ablation device.

24. The method as claimed in claim 23 further comprising the step of repeating said detecting step after said step of actuating said ablation device.

25. The method as claimed in claim 24 further comprising the step of withdrawing said sensing probe and reinserting said sensing probe after detecting electrical signals the first time and reinserting said sensing probe prior to repeating said detecting step.

26. The method as claimed in claim 21 further comprising the step of injecting a contrast medium through said passageway while said sensing probe is not disposed therein.

27. The method as claimed in claim 21 wherein said port is substantially coaxial with said loop-like region and step of advancing said sensing probe is performed so that said distal region forms a hoop within said loop-like region.

28. The method as claimed in claim 27 wherein said step of positioning said ablation device is performed so that said loop-like region at least partially surrounds the ostium of a pulmonary vein and said port is aligned with such ostium.

29. The method as claimed in claim 28 wherein said step of advancing said sensing probe is performed so that said hoop is disposed within the ostium or the pulmonary vein.

30. The method as claimed in claim 27 wherein said step of advancing said sensing probe is performed so that said each portion of said sensing region moves out through said port in a forward direction and so that when the sensing probe is fully

advanced, a portion of the sensing probe between the port and the hoop extends rearwardly so that the hoop lies in proximity to the ablation device.

5 31. A probe including a probe body having an undeployed condition and a deployed condition, and one or more functional elements disposed along said probe body, said probe body being elongated and flexible in said undeployed condition, said probe body in said deployed condition including:

10 (a) a base portion extending in a distal direction to a distal end;

(b) a limb extending from the distal end of said base portion in a radial direction transverse to said distal direction and also extending in a proximal direction opposite to said distal direction, said limb having an outer end remote from said base portion;

15 (c) a hoop region extending from said outer end of said limb around said base portion, said hoop including one or more of said functional elements.

20 32. The probe as claimed in claim 31 in combination with an introducer structure having proximal and distal ends, a port adjacent the distal end of the introducer and a passageway extending from adjacent said proximal end to said port, said probe body in said undeployed condition being slideable in said passageway, said base portion of said probe body in said deployed condition projecting from said port.

33. A combination as claimed in claim 32 wherein said hoop region of said probe body extends around said introducer structure when said probe body is in said deployed condition.

30 34. A combination as claimed in claim 32 wherein said introducer structure includes a catheter having proximal and distal ends and an expansible ablation device mounted to the distal end of said catheter, said ablation device having a collapsed condition and an expanded condition, said ablation device being operative to apply energy to tissue in proximity to

the ablation device when the ablation device is in said expanded condition.

35. A combination as claimed in claim 34 wherein said ablation device is adapted to apply energy in a loop-like region
5 surrounding said port.

36. A combination as claimed in claim 35 wherein said ablation device includes an ultrasonic emitter and an expansible energy-directing structure adapted to direct ultrasonic energy from said emitter into said loop-like region when said expansible
10 ablation device is in said expanded condition.

37. Apparatus as claimed in claim 36 wherein said expansible ablation device defines a forward-to-rearward axis, said loop-like region having an axis substantially coaxial with said forward-to-rearward axis of said ablation device, said energy-directing
15 structure being arranged to direct said ultrasonic energy into said region in a direction having a forward component.

38. Apparatus as claimed in claim 37 wherein said port is disposed adjacent to said forward-to-rearward axis, said base portion of said probe body extends substantially parallel to said
20 forward-to-rearward axis of said ablation device and said hoop region of said probe body extends around said forward-to-rearward axis when said energy-directing structure is in said expanded condition and said probe is in said deployed condition.

39. Apparatus as claimed in claim 38 wherein said
25 energy-directing structure in said expanded condition includes a distal wall, said loop-like region overlying said distal wall, said hoop region of said probe body overlying said distal wall when said energy-directing structure is in said expanded condition and said probe is in said deployed condition.

30 40. Apparatus as claimed in claim 39 wherein said energy-directing structure includes a projection extending forwardly from said distal wall when said energy-directing structure is in said expanded condition, said axis extending through said projection, said port being disposed on said

projection, said hoop region of said probe body encircling said projection when said probe is in said deployed condition.

41. Apparatus as claimed in claim 39 wherein said port extends through said distal wall.

5 42. Apparatus as claimed in claim 32 wherein said probe is removably received in said passageway.

10 43. Apparatus as claimed in claim 32 wherein said probe body is resilient and a portion of the probe body projecting out of said port is adapted to deform under its own resilience to form said limb and said hoop region when said probe body is advanced distally relative to said introducer structure.

FIG. 1

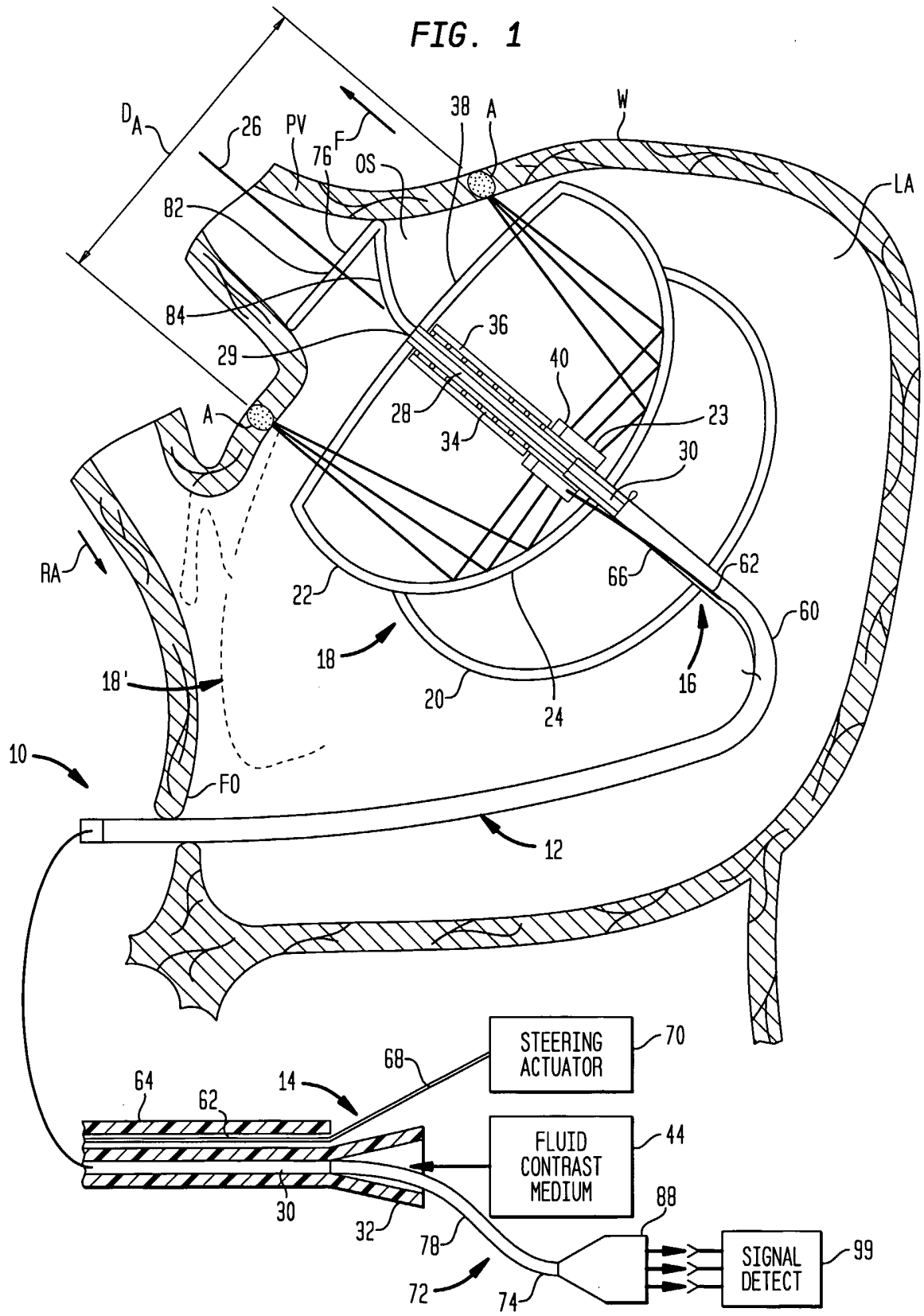

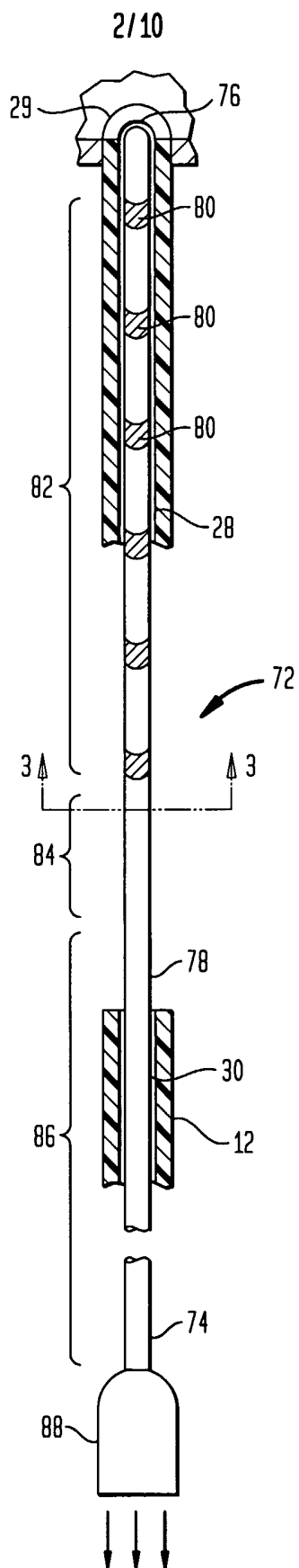

FIG. 2

FIG. 3

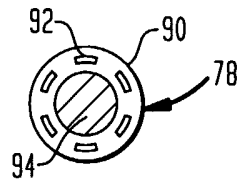

FIG. 4

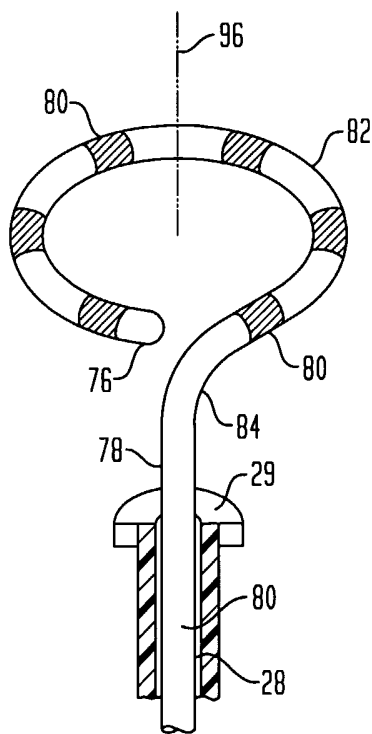

FIG. 5

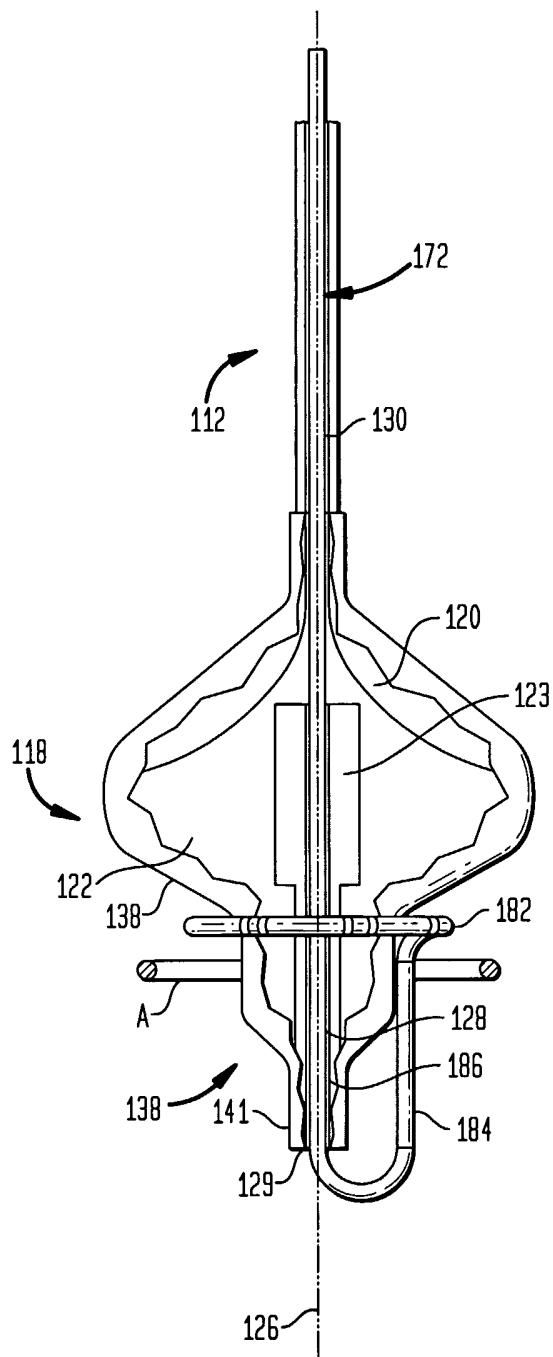

FIG. 6

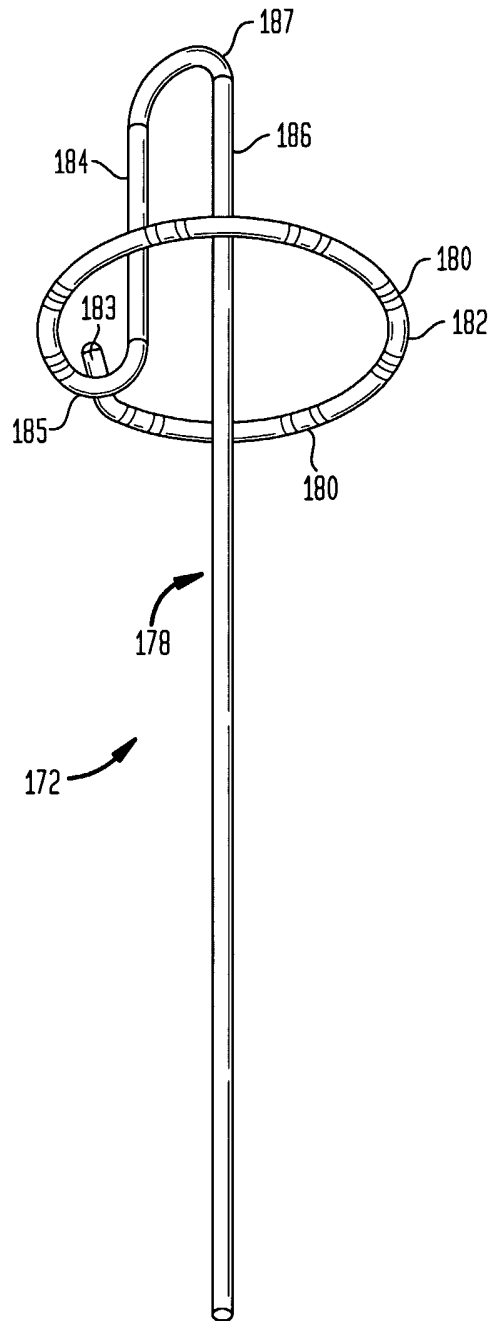

FIG. 7

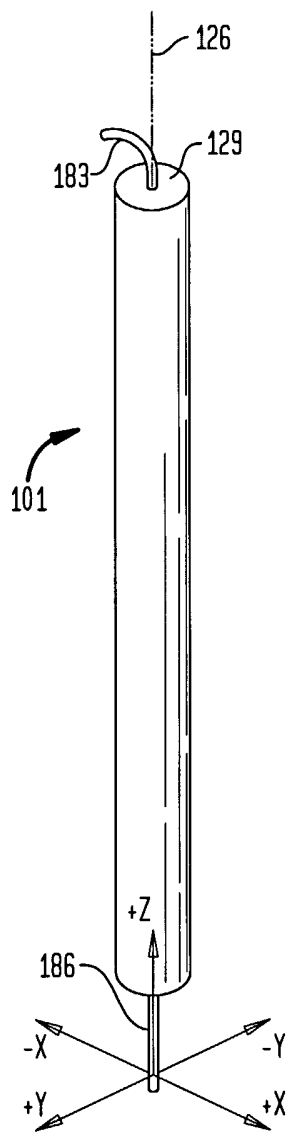

FIG. 8

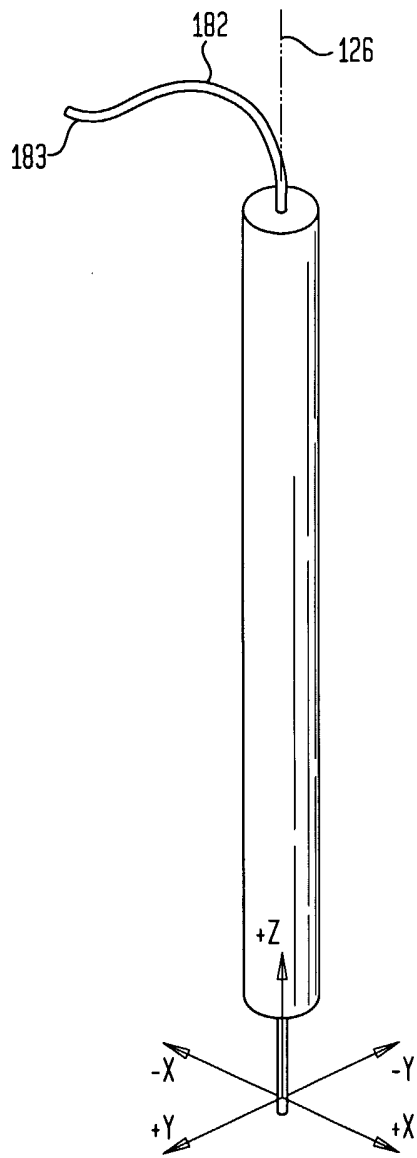

FIG. 9

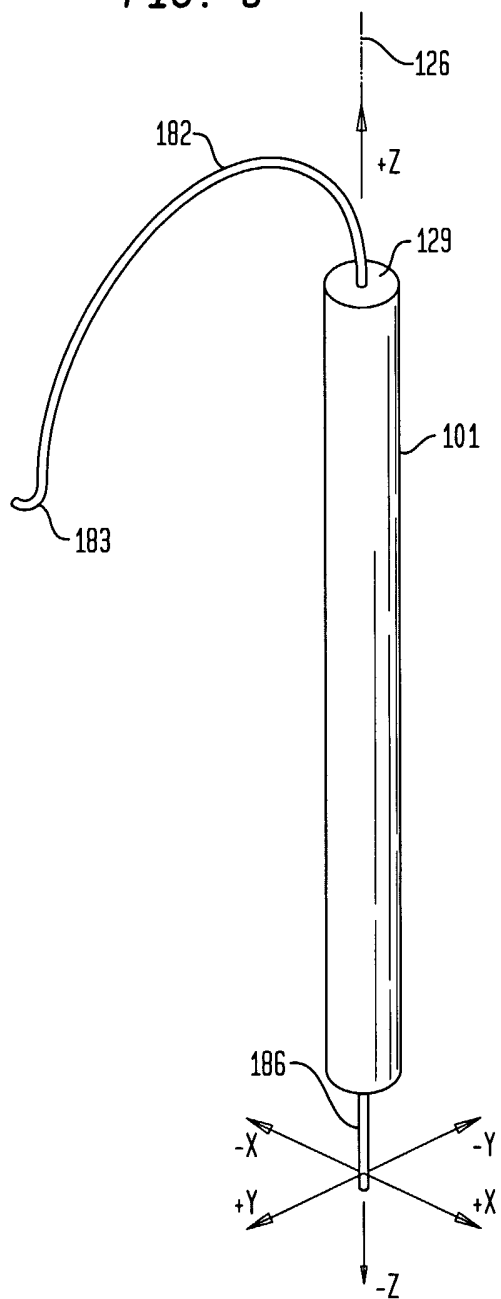

FIG. 10

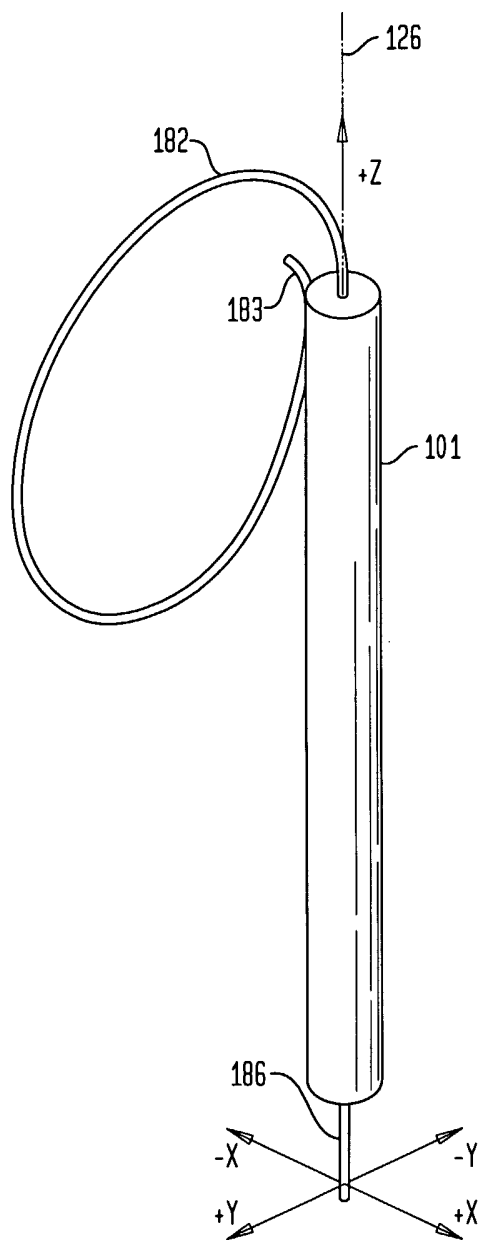

FIG. 11

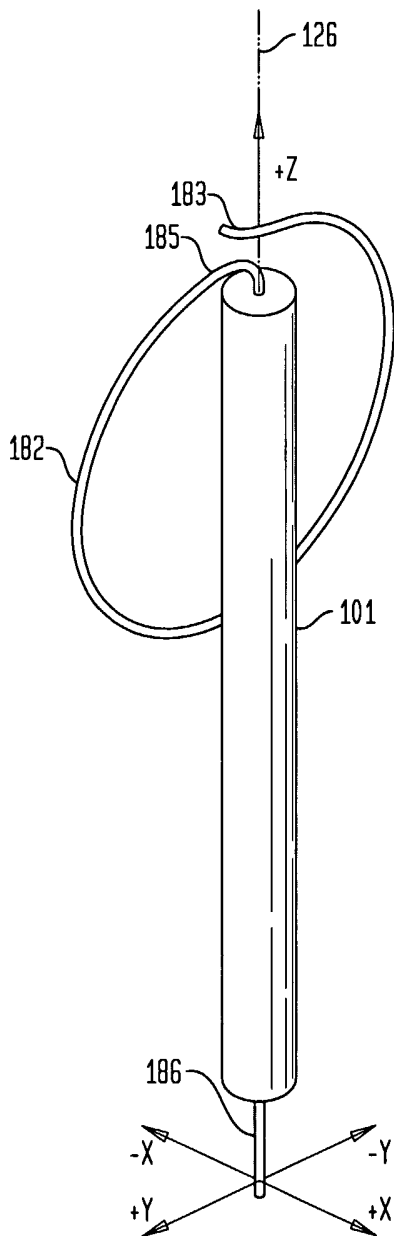

FIG. 12

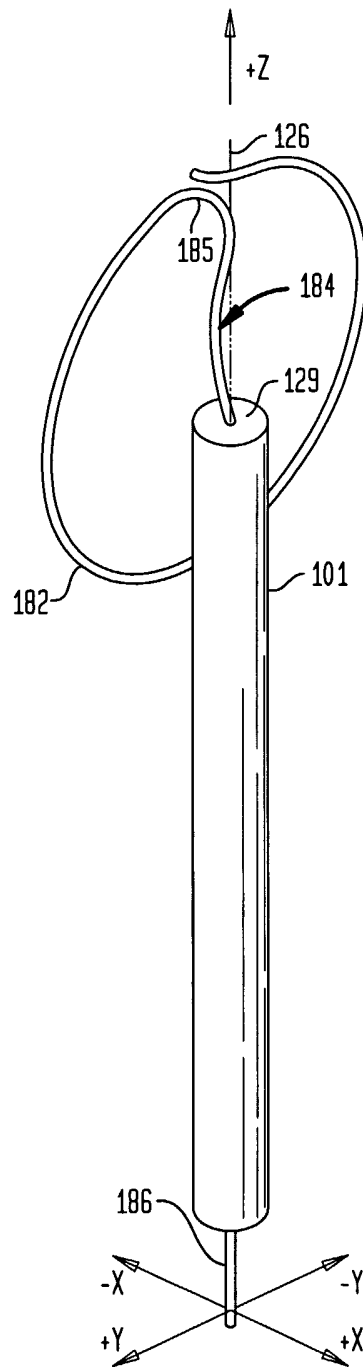

FIG. 13

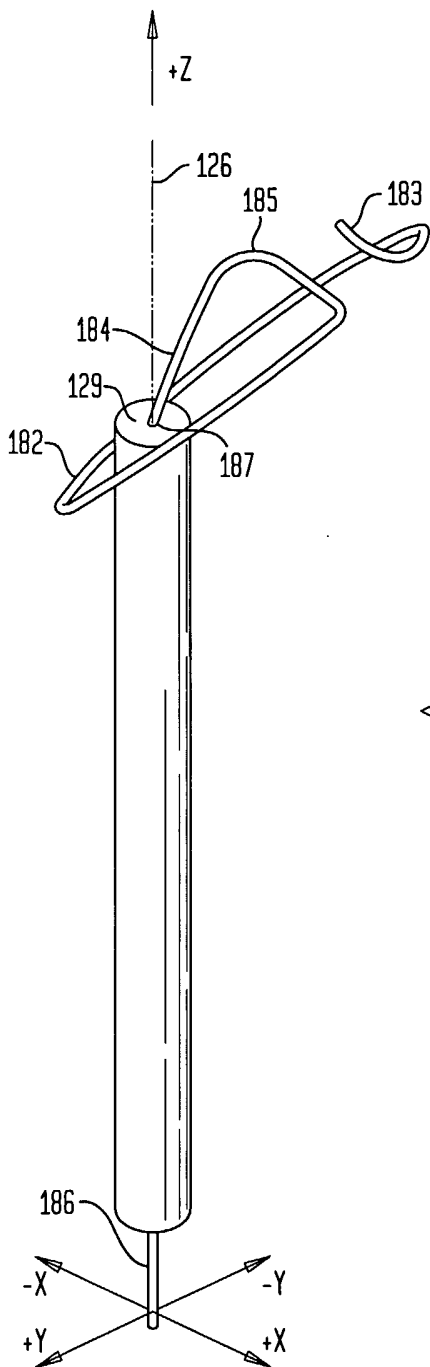

FIG. 14

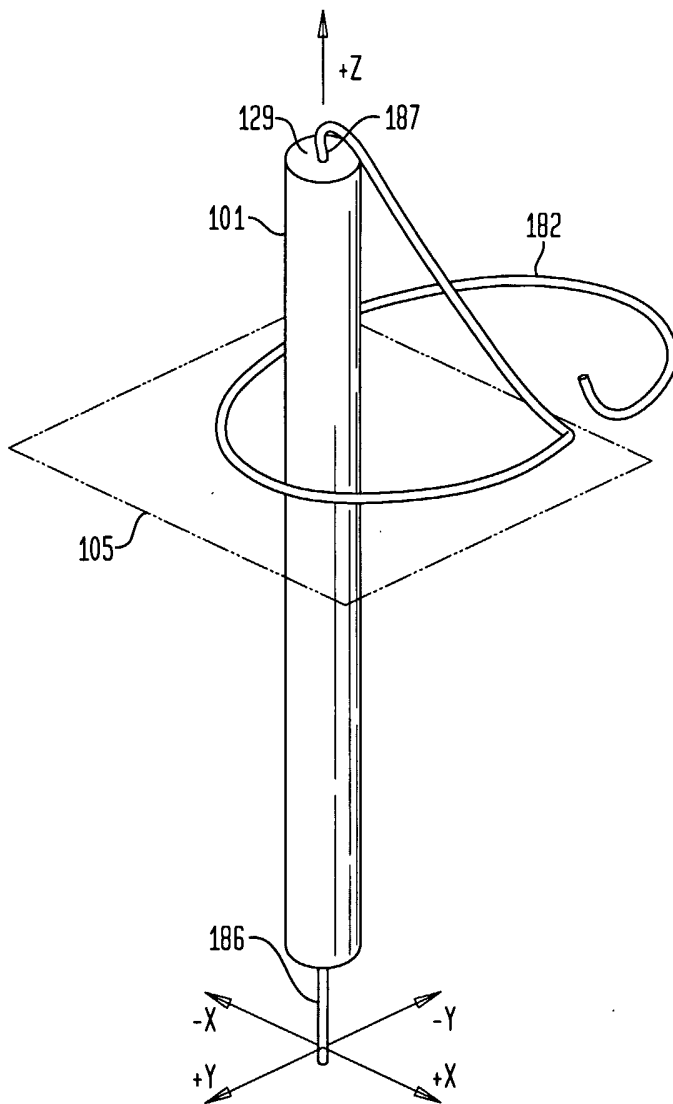

FIG. 15

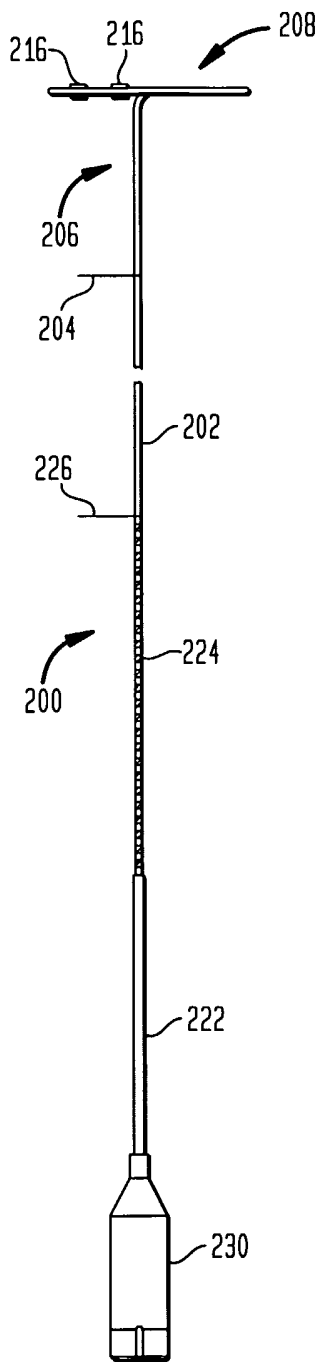

FIG. 17

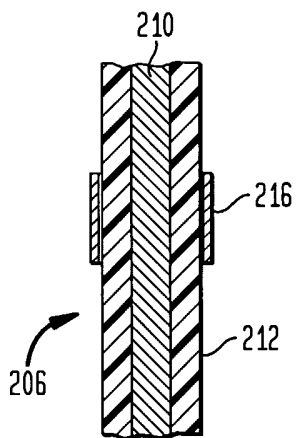

FIG. 18

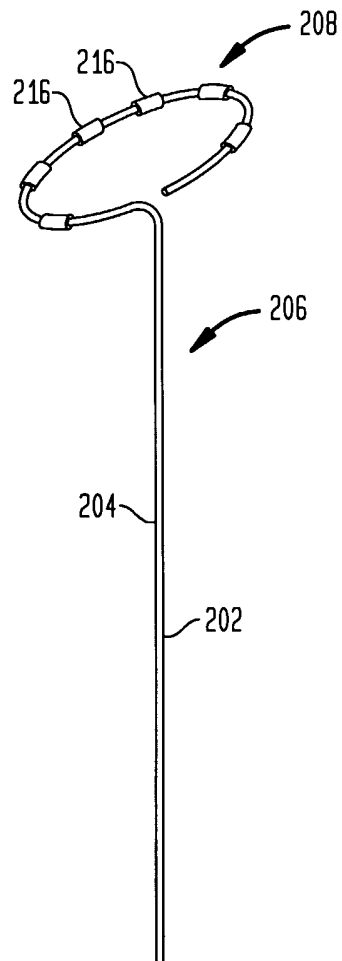
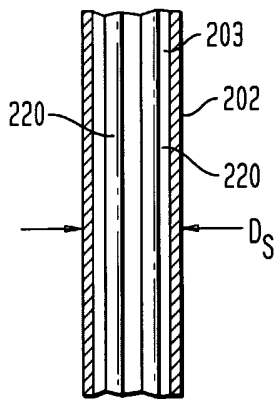

FIG. 16



INTERNATIONAL SEARCH REPORT

International application No.

PCT/US05/13424

<p>A. CLASSIFICATION OF SUBJECT MATTER IPC(7) : A61B 18/18 US CL : 606/41 According to International Patent Classification (IPC) or to both national classification and IPC</p>																							
<p>B. FIELDS SEARCHED Minimum documentation searched (classification system followed by classification symbols) U.S. : 606/27-31, 41, 45-50; 607/101,102,116,122 Documentation searched other than minimum documentation to the extent that such documents are included in the fields searched Electronic data base consulted during the international search (name of data base and, where practicable, search terms used)</p>																							
<p>C. DOCUMENTS CONSIDERED TO BE RELEVANT</p> <table border="1"> <thead> <tr> <th>Category *</th> <th>Citation of document, with indication, where appropriate, of the relevant passages</th> <th>Relevant to claim No.</th> </tr> </thead> <tbody> <tr> <td>X</td> <td>US 6,325,797 B1 (Stewart et al) 04 December 2001, whole document</td> <td>17-20, 31-33</td> </tr> <tr> <td>---</td> <td></td> <td></td> </tr> <tr> <td>Y</td> <td></td> <td>1-3,5-16, 21-43</td> </tr> <tr> <td>Y</td> <td>US 6,315,778 B1 (Gambale et al) 13 November 2001, whole document</td> <td>1-3, 5-16, 21-43</td> </tr> <tr> <td>A</td> <td>US 5,680,860 A (Imran) 28 October 1997, whole document</td> <td>1-43</td> </tr> <tr> <td>A</td> <td>US 6,635,054 B2 (Fjield et al) 21 October 2003, whole document</td> <td>1-43</td> </tr> </tbody> </table>			Category *	Citation of document, with indication, where appropriate, of the relevant passages	Relevant to claim No.	X	US 6,325,797 B1 (Stewart et al) 04 December 2001, whole document	17-20, 31-33	---			Y		1-3,5-16, 21-43	Y	US 6,315,778 B1 (Gambale et al) 13 November 2001, whole document	1-3, 5-16, 21-43	A	US 5,680,860 A (Imran) 28 October 1997, whole document	1-43	A	US 6,635,054 B2 (Fjield et al) 21 October 2003, whole document	1-43
Category *	Citation of document, with indication, where appropriate, of the relevant passages	Relevant to claim No.																					
X	US 6,325,797 B1 (Stewart et al) 04 December 2001, whole document	17-20, 31-33																					

Y		1-3,5-16, 21-43																					
Y	US 6,315,778 B1 (Gambale et al) 13 November 2001, whole document	1-3, 5-16, 21-43																					
A	US 5,680,860 A (Imran) 28 October 1997, whole document	1-43																					
A	US 6,635,054 B2 (Fjield et al) 21 October 2003, whole document	1-43																					
<p><input type="checkbox"/> Further documents are listed in the continuation of Box C. <input type="checkbox"/> See patent family annex.</p>																							
<p>* Special categories of cited documents:</p> <table border="0"> <tr> <td>"A" document defining the general state of the art which is not considered to be of particular relevance</td> <td>"T" later document published after the international filing date or priority date and not in conflict with the application but cited to understand the principle or theory underlying the invention</td> </tr> <tr> <td>"E" earlier application or patent published on or after the international filing date</td> <td>"X" document of particular relevance; the claimed invention cannot be considered novel or cannot be considered to involve an inventive step when the document is taken alone</td> </tr> <tr> <td>"L" document which may throw doubts on priority claim(s) or which is cited to establish the publication date of another citation or other special reason (as specified)</td> <td>"Y" document of particular relevance; the claimed invention cannot be considered to involve an inventive step when the document is combined with one or more other such documents, such combination being obvious to a person skilled in the art</td> </tr> <tr> <td>"O" document referring to an oral disclosure, use, exhibition or other means</td> <td>"&" document member of the same patent family</td> </tr> <tr> <td>"P" document published prior to the international filing date but later than the priority date claimed</td> <td></td> </tr> </table>			"A" document defining the general state of the art which is not considered to be of particular relevance	"T" later document published after the international filing date or priority date and not in conflict with the application but cited to understand the principle or theory underlying the invention	"E" earlier application or patent published on or after the international filing date	"X" document of particular relevance; the claimed invention cannot be considered novel or cannot be considered to involve an inventive step when the document is taken alone	"L" document which may throw doubts on priority claim(s) or which is cited to establish the publication date of another citation or other special reason (as specified)	"Y" document of particular relevance; the claimed invention cannot be considered to involve an inventive step when the document is combined with one or more other such documents, such combination being obvious to a person skilled in the art	"O" document referring to an oral disclosure, use, exhibition or other means	"&" document member of the same patent family	"P" document published prior to the international filing date but later than the priority date claimed												
"A" document defining the general state of the art which is not considered to be of particular relevance	"T" later document published after the international filing date or priority date and not in conflict with the application but cited to understand the principle or theory underlying the invention																						
"E" earlier application or patent published on or after the international filing date	"X" document of particular relevance; the claimed invention cannot be considered novel or cannot be considered to involve an inventive step when the document is taken alone																						
"L" document which may throw doubts on priority claim(s) or which is cited to establish the publication date of another citation or other special reason (as specified)	"Y" document of particular relevance; the claimed invention cannot be considered to involve an inventive step when the document is combined with one or more other such documents, such combination being obvious to a person skilled in the art																						
"O" document referring to an oral disclosure, use, exhibition or other means	"&" document member of the same patent family																						
"P" document published prior to the international filing date but later than the priority date claimed																							
<p>Date of the actual completion of the international search 27 July 2005 (27.07.2005)</p>		<p>Date of mailing of the international search report 15 SEP 2005</p>																					
<p>Name and mailing address of the ISA/US Mail Stop PCT, Attn: ISA/US Commissioner for Patents P.O. Box 1450 Alexandria, Virginia 22313-1450 Facsimile No. (703) 305-3230</p>		<p>Authorized officer Linda Dvorak Telephone No. (703) 308-0858</p>																					