



(86) Date de dépôt PCT/PCT Filing Date: 2011/07/25
 (87) Date publication PCT/PCT Publication Date: 2012/02/02
 (85) Entrée phase nationale/National Entry: 2014/01/27
 (86) N° demande PCT/PCT Application No.: IB 2011/053307
 (87) N° publication PCT/PCT Publication No.: 2012/014145
 (30) Priorité/Priority: 2010/07/26 (US61/367,790)

(51) Cl.Int./Int.Cl. *A61B 18/22* (2006.01),
G01B 11/14 (2006.01), *A61N 5/06* (2006.01)
 (71) Demandeur/Applicant:
LUMENIS LTD., IL
 (72) Inventeurs/Inventors:
KHACHATUROV, ARKADY, IL;
VOITSECHOV, URI, IL;
KOIFMAN, IGAL, IL
 (74) Agent: NELLIGAN O'BRIEN PAYNE LLP

(54) Titre : ESTIMATION DE DISTANCE ENTRE UNE EXTREMITÉ DE FIBRE ET UN TISSU UTILISANT UNE
MODULATION D'OUVERTURE NUMÉRIQUE
 (54) Title: DISTANCE ESTIMATION BETWEEN A FIBER END AND A TISSUE USING NUMERICAL APERTURE
MODULATION

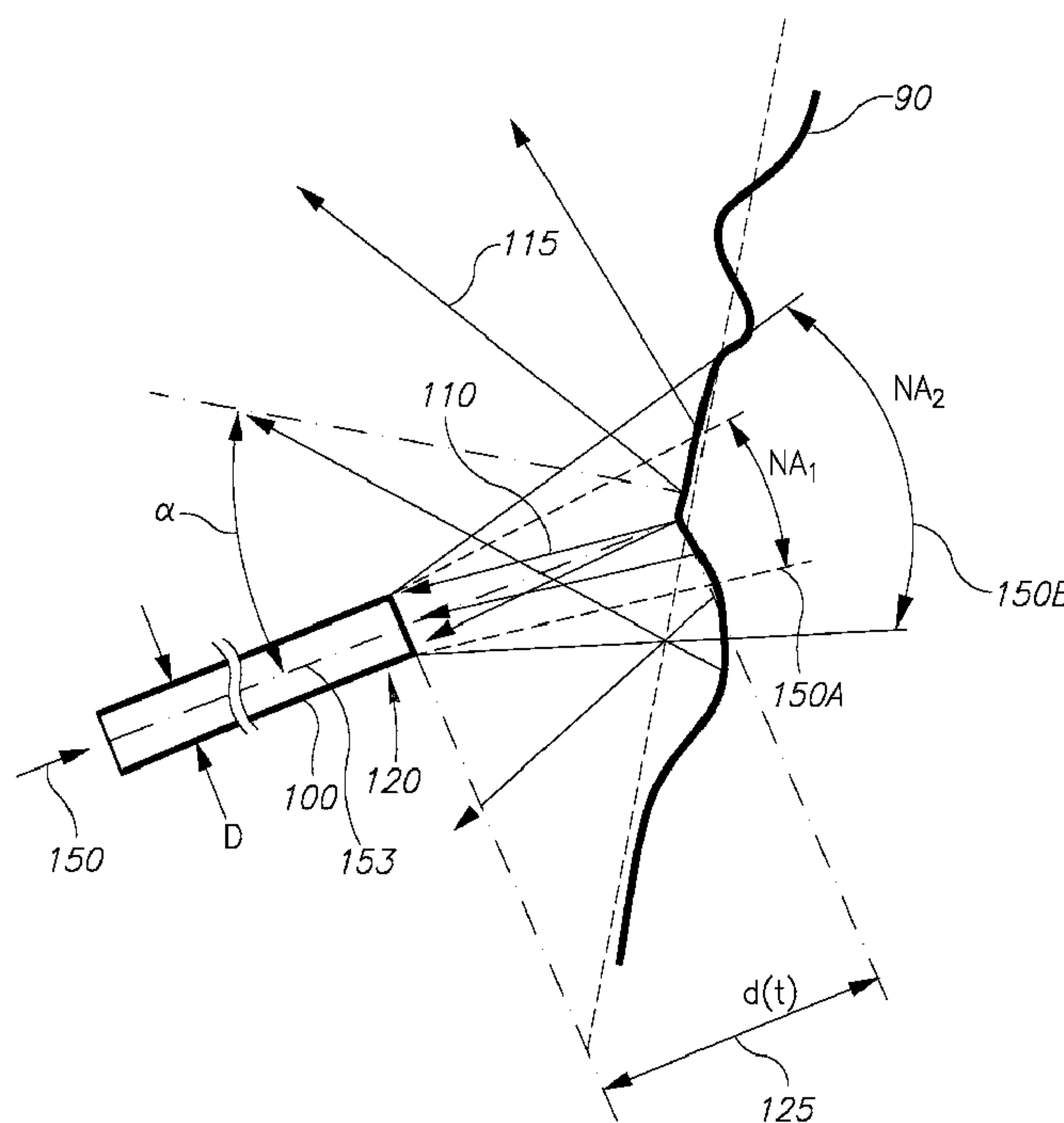


Figure 1

(57) **Abrégé/Abstract:**

A system and method of estimating a distance between the distal end of an optical fiber and treated tissue, to improve treatment efficiency, is provided herein. The estimation is achieved by modulating the numerical aperture of a light beam transmitted through



(57) **Abrégé(suite)/Abstract(continued):**

the fiber to receive reflections from the tissue and distinguish them from other reflections in the fiber, and further by calculating the distance by comparing reflection intensities of beams having different numerical aperture values that illuminate the tissue over a very short period, so that tissue and environment conditions do not change much. Distance estimation may be carried out by modulating the treatment beam itself, or by a light beam transmitted between pulses of a pulsed treatment beam.

(12) INTERNATIONAL APPLICATION PUBLISHED UNDER THE PATENT COOPERATION TREATY (PCT)

(19) World Intellectual Property Organization
International Bureau(43) International Publication Date
2 February 2012 (02.02.2012)(10) International Publication Number
WO 2012/014145 A1

(51) International Patent Classification:

A61B 18/22 (2006.01) A61N 5/06 (2006.01)
G01B 11/14 (2006.01)

(21) International Application Number:

PCT/IB2011/053307

(22) International Filing Date:

25 July 2011 (25.07.2011)

(25) Filing Language:

English

(26) Publication Language:

English

(30) Priority Data:

61/367,790 26 July 2010 (26.07.2010) US

(71) Applicant (for all designated States except US): LUMENIS LTD. [IL/IL]; 6 Hakidma Street, Northern Industrial Zone, 20692 Yokneam Ilit (IL).

(72) Inventors; and

(75) Inventors/Applicants (for US only): KHACHATUROV, Arkady [IL/IL]; 42/4 Raziel David Street, 32495 Haifa (IL). VOITSECHOV, Uri [IL/IL]; Amirim 35 Street,

20115 Moshav Amirim (IL). KOIFMAN, Igal [IL/IL]; 21 Palmach Street, 38286 Hadera (IL).

(74) Agent: FISHER WEILE JONES; 26 Habarzel Street, Ramat Hachayal, 69710 Tel-Aviv (IL).

(81) Designated States (unless otherwise indicated, for every kind of national protection available): AE, AG, AL, AM, AO, AT, AU, AZ, BA, BB, BG, BH, BR, BW, BY, BZ, CA, CH, CL, CN, CO, CR, CU, CZ, DE, DK, DM, DO, DZ, EC, EE, EG, ES, FI, GB, GD, GE, GH, GM, GT, HN, HR, HU, ID, IL, IN, IS, JP, KE, KG, KM, KN, KP, KR, KZ, LA, LC, LK, LR, LS, LT, LU, LY, MA, MD, ME, MG, MK, MN, MW, MX, MY, MZ, NA, NG, NI, NO, NZ, OM, PE, PG, PH, PL, PT, RO, RS, RU, SC, SD, SE, SG, SK, SL, SM, ST, SV, SY, TH, TJ, TM, TN, TR, TT, TZ, UA, UG, US, UZ, VC, VN, ZA, ZM, ZW.

(84) Designated States (unless otherwise indicated, for every kind of regional protection available): ARIPO (BW, GH, GM, KE, LR, LS, MW, MZ, NA, SD, SL, SZ, TZ, UG, ZM, ZW), Eurasian (AM, AZ, BY, KG, KZ, MD, RU, TJ, TM), European (AL, AT, BE, BG, CH, CY, CZ, DE, DK, EE, ES, FI, FR, GB, GR, HR, HU, IE, IS, IT, LT, LU,

[Continued on next page]

(54) Title: DISTANCE ESTIMATION BETWEEN A FIBER END AND A TISSUE USING NUMERICAL APERTURE MODULATION

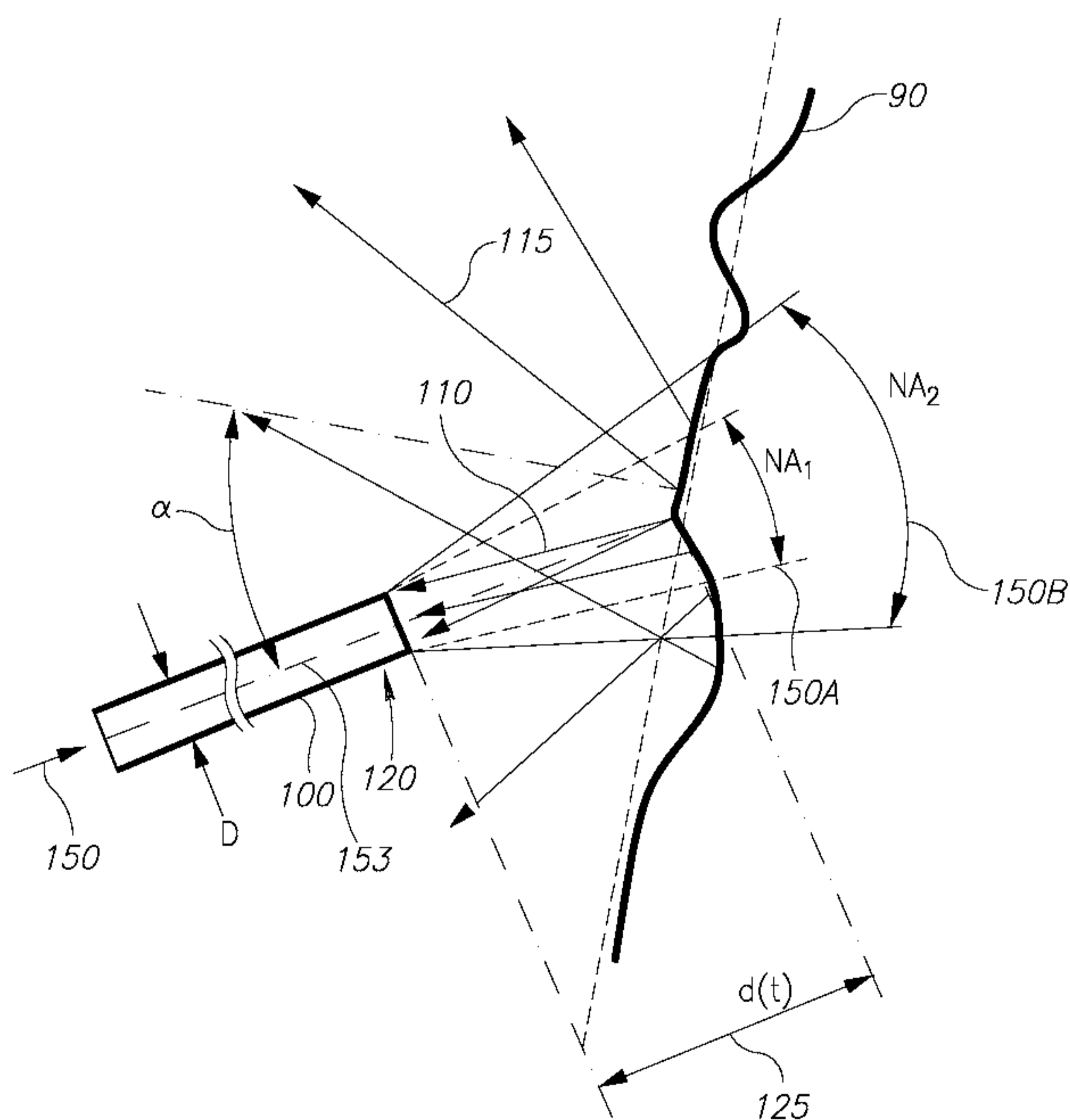


Figure 1

(57) Abstract: A system and method of estimating a distance between the distal end of an optical fiber and treated tissue, to improve treatment efficiency, is provided herein. The estimation is achieved by modulating the numerical aperture of a light beam transmitted through the fiber to receive reflections from the tissue and distinguish them from other reflections in the fiber, and further by calculating the distance by comparing reflection intensities of beams having different numerical aperture values that illuminate the tissue over a very short period, so that tissue and environment conditions do not change much. Distance estimation may be carried out by modulating the treatment beam itself, or by a light beam transmitted between pulses of a pulsed treatment beam.

WO 2012/014145 A1 

LV, MC, MK, MT, NL, NO, PL, PT, RO, RS, SE, SI, SK, **Published:**
SM, TR), OAPI (BF, BJ, CF, CG, CI, CM, GA, GN, GQ, — *with international search report (Art. 21(3))*
GW, ML, MR, NE, SN, TD, TG).

DISTANCE ESTIMATION BETWEEN A FIBER END AND A TISSUE USING NUMERICAL APERTURE MODULATION

BACKGROUND

1. TECHNICAL FIELD

[0001] The present invention relates to optical fibers and more particularly, to laser treatment devices.

2. DISCUSSION OF THE RELATED ART

[0002] Many non-invasive or minimally invasive treatment methods involve delivering energy to a tissue by irradiating the tissue with a laser beam through an optical fiber. Treatment efficiency depends strongly on the relative position and orientation of the fiber tip in respect to the tissue. However these are very difficult to measure due to the permanent motion of the fiber and permanent changes in the treated tissue and its environment. Hence, currently physicians are in the dark regarding the location of the fiber tip in respect to the treated tissue.

BRIEF SUMMARY

[0003] One aspect of the invention provides a method comprising: modulating a numerical aperture of a light beam transmitted through an optical fiber and directed at a target tissue via a distal end of the optical fiber, measuring intensity values of reflections of the light beam reflected from the target tissue and transmitted backward through the optical fiber, and estimating, by comparing intensity values of the reflections associated with two or more numerical aperture values, a distance between the target tissue and the distal end of the optical fiber.

BRIEF DESCRIPTION OF THE DRAWINGS

[0004] For a better understanding of embodiments of the invention and to show how the same may be carried into effect, reference will now be made, purely by way of example, to the accompanying drawings in which like numerals designate corresponding elements or sections throughout.

[0005] In the accompanying drawings:

Figures 1-6 are high level schematic illustrations of a modulation of the numerical aperture of a light beam, according to some embodiments of the invention. **Figure 1** illustrates a reflection of the light beam from an illuminated target tissue, **Figures 2** and **3** schematically illustrate the transmission of the light beam and measurement of the reflection, and **Figures 4-6** illustrate various modulation methods of the numerical aperture of the light beam, according to some embodiments of the invention.

Figure 7 is a high level flowchart illustrating a method according to some embodiments of the invention.

[0006] The drawings together with the following detailed description make apparent to those skilled in the art how the invention may be embodied in practice.

DETAILED DESCRIPTION

[0007] Prior to setting forth the detailed description, it may be helpful to set forth definitions of certain terms that will be used hereinafter.

[0008] The term “laser” as used herein in this application refers to any type of laser – For example solid state (e.g. Neodymium, Erbium, Holmium, Thulium or Alexandrite), diode (e.g. in various wavelengths, such as in the range 532-1600 nm), gas (e.g. CO₂, Argon) or fiber laser (e.g. Neodymium, Erbium, Holmium, Thulium or Alexandrite). Furthermore, laser beams referred to in the application may be continuous, pulsed, Q-switched, or any other temporal pattern.

[0009] The term “treatment beam” as used herein in this application refers to an intense laser beam transferred through an optical fiber to treat a target tissue. For example, treatment beam may be a pulsed laser beam or any other laser beam as defined above. The treatment may be ablative or non-ablative, as determined by the beam intensity in respect to a tissue ablation threshold of approximately 10 kW/cm².

[0010] The term “aiming beam” as used herein in this application refers to a light beam with a modulated numerical aperture that is used to estimate the distance between the fiber tip and the target tissue. The aiming beam may be a low energy beam that is not configured to provide treatment or it may be a non-ablative treatment beam, which is modulated (by numerical aperture) at specific periods of its operation to provide the additional function of distance estimation. The aiming beam may be

generated e.g. by the same laser source which generates the treatment beam or by another laser source. The aiming beam may be transmitted to the tissue during the treatment or during interruptions in the treatment, such as between pulses of a pulsed treatment beam. The term “measurement beam” as used herein in this application refers to the aiming beam.

[0011] The term “light beam” as used herein in this application refers to any light beam transferred through an optical fiber and may refer to either the aiming beam or the treatment beam, as well as to a single beam with temporally varying characteristics, such as to alternately function as a treatment beam and as an aiming beam. Any of the beams referred to in the application may be a laser beam, as defined above.

[0012] The term “estimated distance” as used herein in this application refers to an estimation of a distance between the fiber’s distal end and the target tissue. As such a distance is difficult to even define (see explanation below), the estimated distance refers to a value reflecting the relative proximity of the distal fiber end and the target tissue, and does not necessarily have a rigorous independent definition.

[0013] The term “proximal end of the optical fiber” as used herein in this application refers to the fiber end through which the light beam enters the fiber and propagates towards the distal end of the fiber, which is close to the treated tissue. Reference to measurements carried out at the proximal end relate to the vicinity of the proximal end, e.g. may be carried out by optical equipment coupled to the proximal end, or by equipment receiving beams diverted from the proximal end.

[0014] With specific reference now to the drawings in detail, it is stressed that the particulars shown are by way of example and for purposes of illustrative discussion of the preferred embodiments of the present invention only, and are presented in the cause of providing what is believed to be the most useful and readily understood description of the principles and conceptual aspects of the invention. In this regard, no attempt is made to show structural details of the invention in more detail than is necessary for a fundamental understanding of the invention, the description taken with the drawings making apparent to those skilled in the art how the several forms of the invention may be embodied in practice.

[0015] Before explaining at least one embodiment of the invention in detail, it is to be understood that the invention is not limited in its application to the details of construction and the arrangement of the components set forth in the following description or illustrated in the drawings. The invention is applicable to other embodiments or of being practiced or carried out in various ways. Also, it is to be understood that the phraseology and terminology employed herein is for the purpose of description and should not be regarded as limiting.

[0016] **Figures 1-6** are high level schematic illustrations of a modulation of the numerical aperture of a light beam **150**, according to some embodiments of the invention. **Figure 1** illustrates a reflection **110** of light beam **150** from an illuminated target tissue **90**, **Figures 2 and 3** schematically illustrate the transmission of light beam **150** as an aiming beam and/or as a treatment beam and measurement of reflection **110**, and **Figures 4-6** illustrate various modulation methods of the numerical aperture of light beam **150**.

[0017] Light beam **150** propagates along optical fiber **100** and illuminates tissue **90**. Tissue **90** reflects some of the light (**115**) away from optical fiber **100**, while a part of the light re-enters optical fiber **100** at the fiber's distal end **120** as reflection **110**. Reflection **110** is transmitted backward in optical fiber **100** from distal end **120** to the fiber's proximal end **130** and is detected when emerging from proximal end **130**. Both entering light beam **150** and reflection **110** may be delivered to and from proximal end **130** (respectively) by optics such as lenses, mirror, reflectors etc. In particular, the measurement of the reflection intensities may be carried out on reflection **110** that is diverted after exiting proximal end **130** and directed to sensor **320**.

[0018] The current invention presents a method to evaluate a distance **125** of distal end **120** from tissue **90** using reflection **110** as measured at proximal end **130**. Distance **125** changes during the manipulation of fiber **100** and is denoted as a function of time by $d(t)$.

[0019] Several difficulties impede such a straight forward measurement. (i) Separation of reflection **110** from reflections of light beam **150** from distal and proximal ends **120**, **130** (respectively, reflections **91** and **99**, **Figure 2**) of optical fiber **100** is difficult, as the intensity of reflection **110** is much smaller than those of other reflections **91**, **99** in fiber **100**. (ii) The reflecting tissue **90** surface geometry is not

regular and its optical properties are neither stable nor predictable. Environment transparency, related to debris, bubbles, flushing and other liquids or gas between tissue **90** and fiber distal end **120**, changes continuously. These effects are especially imminent in cases of ablative treatment. As fiber **100** moves in respect to tissue **90** and as treatment is applied to tissue, both tissue reflectivity and tissue environment may change strongly and abruptly. (iii) The location (distance d) and orientation (angle α) of fiber **100** in respect to tissue **90** change continuously.

[0020] In such working conditions it is not even possible to exactly define a "distance to the target" (i.e. distance **125**). In any case it is clear that it could be only somehow averaged distance. The presented invention however, allows a crude estimation of distance **125** from reflection **110**. For the stated purpose, diffusive and specular reflections from tissue surface are not differentiated.

[0021] Fiber's distal end **120** illuminates tissue **90** within the limits of light beam numerical aperture, NA (in respect to the fiber's optical axis **153**). Because the tissue surface is not plane, the angle α and the distance d could be determined only with somewhat uncertainty. The light, coming back to the fiber tip (reflection **110**), is reflected from relatively small portion of illuminated tissue surface, so that one may consider averaged values of α and of d from this small portion. The signal $S(t)$ detected at proximal end **130** of fiber **100** is directly proportional to the light intensity I of reflection **110**, and may be expressed by the following **Equation 1**, with D denoting the fiber core diameter.

Equation 1:

$$S(t) = \frac{\pi D^2}{4} I = \frac{\pi D^2}{4} \frac{4p_0 \cos \alpha}{\pi(D+d \cdot NA)^2} \cdot Sct(R, g, \alpha, d)$$

[0022] The first term in this expression ($\pi D^2/4$) is the fiber cross section; the second one represents tissue illumination intensity ($4p_0 \cos(\alpha) / \pi(D+d \cdot NA)^2$), created by optical power p_0 irradiated from fiber distal end **120** (assuming uniform angular distribution of the light beam). The last term, $Sct(R, g, \alpha, d)$ is a scattering function, which determines how much energy is reflected toward fiber **100**, including all effects of light absorption and scattering by a media between fiber end **120** and tissue surface **90**. This function, $Sct(R, g, \alpha, d)$, depends particularly on tissue reflectance R and surface geometry g (each of them includes several parameters). Keeping in mind that

almost all of them are variable in time the expression for detected signal could be re-written as **Equation 2**:

Equation 2:

$$S(t) = \frac{F(t)}{\left(1 + \frac{d(t)}{D} \cdot NA(t)\right)^2}$$

where $F(t)$ is relatively slow arbitrary function of time. It is impossible to use this equation to directly calculate distance **125** - $d(t)$, because the signal variation may be caused by unpredictable $F(t)$ function change as well.

[0023] However, as the current invention discloses, the problem may be circumvented by modulating the numerical aperture NA of incident light beam **150** in its function as an aiming beam. For the purpose of explanation, the simplest implementation of this principle is discussed in the following, but should not be taken as limiting the current invention. Light beam **150** may be modulated to have periodically alternating values of light beam **150**'s numerical aperture (NA_1 , NA_2 for light beams **150A**, **150B**, respectively, neither of which exceeding the fiber numerical aperture). If the period between two consecutive measurement (S_1 , S_2) is short enough to substantially minimize changes in $d(t)$, $\alpha(t)$ and other parameters that determine $F(t)$, then the signal magnitude $S(t)$ varies mainly due to NA variation. Under such conditions, the unknown function $F(t)$ could be eliminated by forming the ratio presented in **Equation 3** with minimal level of inaccuracies.

Equation 3:

$$\frac{S_1}{S_2} = \left(\frac{1 + \frac{d(t)}{D} \cdot NA_2}{1 + \frac{d(t)}{D} \cdot NA_1}\right)^2$$

[0024] **Equation 3** can be readily solved for the distance $d(t)$, to reach the expression of **Equation 4**:

Equation 4:

$$d(t) = \frac{D \cdot \left(1 - \sqrt{\frac{S_1}{S_2}}\right)}{NA_1 \cdot \sqrt{\frac{S_1}{S_2}} - NA_2}$$

[0025] Clearly, the same principle may be applied to estimate $d(t)$ by using several numerical aperture values NA_1, NA_2, \dots, NA_n , or a continuous range of numerical aperture values, using an analogous calculation to derive $d(t)$ from the reflection intensities.

[0026] Considering the light reflected from the both proximal and distal fiber ends (130, 120 respectively) as one of the noise components, the NA modulation significantly improves the signal to noise ratio, because, in principle, only for the light scattered from the tissue (reflection 110) this kind of modulation results in the light intensity modulation.

[0027] Thus the NA modulation, in principle, allows solving of all three problems mentioned above. The proposed NA modulation is applicable to both diffusive and specular reflection, because the only difference between diffusive and specular reflection, relates to $Sct(R, g, \alpha, d)$ function which may be cancelled forming **Equation 3** allowing reasonable distance estimation.

[0028] Hence, the following method achieves the goal of evaluating the distance between fiber distal end 120 and tissue 90 under the treatment using light beam 150 as an aiming beam.

[0029] **Figure 7** is a high level flowchart illustrating a method 200 according to some embodiments of the invention. Method 200 generates an estimation of distance 125 from comparing the intensities of light beams 150A and 150B having different numerical aperture values.

[0030] Method 200 comprises the following stages: modulating a numerical aperture of a light beam transmitted through an optical fiber and directed at a target tissue via a distal end of the optical fiber (stage 210), measuring intensity values of reflections of the light beam reflected from the target tissue and transmitted backward through the optical fiber (stage 220) to the sensor 320, and estimating (stage 230), by comparing intensity values of the reflections associated with two or more numerical aperture values (stage 235), a distance between the target tissue and the distal end of the

optical fiber. Estimation may be carried out according to **Equations 3** and **4**, or an equivalent equation relating to multiple numerical aperture modulation values or continuous numerical aperture modulation values.

[0031] Method **200** may further comprise treating the tissue with a treatment beam (stage **240**), for example a laser beam as defined above. The treatment beam may be operated in any mode, for example a pulsed or a continuous mode. Treatment may be carried out by configuring the light beam to apply a specified treatment to the target tissue during specified periods (stage **241**), in which the light beam is a treatment beam with specified physical characteristics. Modulating the light beam (stage **210**) for the purpose of distance measuring may be carried out during time periods other than the specified periods, in which the light beam is a measurement or an aiming beam (stage **244**). For example, the specified periods may be pulses of a pulsed laser, or periods of a high intensity of the light beam. In another embodiment, the treatment beam may be a continuous wave laser and the modulating (stage **210**) may be carried out whenever the continuous treatment beam is interrupted or is activated below a given energy threshold.

[0032] Treatment may be carried out by transmitting a treatment beam other than the light beam (stage **242**), with specified physical characteristics through the optical fiber to apply a specified treatment to the target tissue. The treatment beam may be applied during specified periods (stage **243**), and modulating the light beam (stage **210**) may be carried out during time periods other than the specified periods, in which the light beam is a measurement or an aiming beam (stage **244**). For example, the treatment beam may be a pulsed laser and the modulating (stage **210**) may be carried out between pulses of the pulsed laser (stage **245**), e.g. between consecutive pulses of the treatment beam, e.g. within 20 msec (corresponding to a 50Hz pulse frequency).

[0033] Method **200** may further comprise selecting a modulation period of the measurement beam (stage **247**) to be shorter than a typical duration in which optical characteristics of the target tissue could be considered constant or with minimum level of changes still allowing reliable distance estimation. For example, modulation period may range between 10 and 0.1 msec, corresponding to a modulation frequency between 0.1 and 10 kHz (respectively). During such short periods, neither biological processes nor manipulation of the fiber change the optical characteristics of the target

the estimation are those associated with measurements performed close in time, in particular consecutive measurements.

[0034] The temporal relation of the modulated light beam and the treatment beam may depend on the type of the treatment. For example, an ablative treatment, causing much tissue damage, may require the modulation, measurement and distance estimation (stages **210**, **220**, **230**) to be carried out only when the immediate treatment effects subside. In case of a non-ablative treatment, the modulation, measurement and distance estimation (stages **210**, **220**, **230**) may be carried out even during treatment (e.g. by modulating the treatment beam, stage **246**, and measuring reflection intensities of the treatment beam at different numerical apertures, and estimating the distance from these values), as long as the treatment does not drastically change the optical characteristics of the target tissue and its surroundings.

[0035] In embodiments, the distance estimation (stage **230**) may be derived from a ratio of reflection intensities at different numerical apertures, e.g. under an assumption of constant optical characteristics, or minimal optical characteristics changes, of the target tissue during the time between these two measurements (stage **231**). The ratio must be configured by using the values measured close enough in time.

[0036] Modulating the aiming beam (stage **210**) may be such that the modulated aiming beam exhibits at least two numerical aperture values (stage **212**) including, for example, approximately a maximal numerical aperture of the fiber (e.g. ca. 0.22) and approximately a minimal, diffraction limited numerical aperture (e.g. in the order of magnitude of λ/D with λ denoting the light wavelength and D denoting the fiber core diameter). Modulation (stage **210**) may be binary and carried out by two alternating numerical aperture values. In embodiments, modulation (stage **210**) is carried out continuously over a specified range of numerical apertures (stage **219**) within a maximal possible range between a numerical aperture of the optical fiber and a diffraction-limit of the optical fiber.

[0037] Modulation (stage **210**) may be carried out by (i) optically switching or multiplexing light beams exhibiting different numerical aperture values prior to entering the fiber (stage **215**) or (ii) beam steering implemented by moving input optics, such as one or more lenses, filters or reflectors along the optical path of the between the laser source and the proximal end of the fiber (stage **216**) or moving the

light beam in respect to the input optics, in a direction perpendicular to an optical axis of the input optics (stage **217**). Additional methods such as beam steering using a grating may be used to modulate the numerical aperture values of the light beams (e.g. by changing beam width – **Figure 4**). A shutter and a chopper may also be used to switch (if needed) the combined beams.

[**0038**] Method **200** may further comprise generating an indication of the estimated distance (stage **250**), such as an acoustic indication, a visual indication (textual, graphical or both), and a vibratory indication.

[**0039**] The distance estimation (stage **230**) may be used to modify the specified physical characteristics and/or the specified periods of the treatment beam application (stage **232**).

[**0040**] Method **200** may be implemented by a tissue distance estimator **301** and a tissue treatment system **300** illustrated in **Figures 2-6**.

[**0041**] **Figures 2** and **3** schematically illustrate the transmission of light beam **150** as the aiming beam and measurement of reflection **110**, and **Figures 4-6** illustrate various modulation methods of the numerical aperture of light beam **150**.

[**0042**] Tissue distance estimator **301** operates in an optical fiber system that comprises light beam **150** emitted onto tissue **90** from distal end **120** of optical fiber **100**. Tissue distance estimator **301** is associated with proximal end **130** of fiber **100** and comprises a modulator **310**, a sensor **320**, and a processing unit **330**: Modulator **310** is arranged to modulate a numerical aperture of light beam **150** transmitted through optical fiber **100** and directed at target tissue **90**, sensor **320** is arranged to measure intensity values of reflections **110** of light beam **150** coming from target tissue **90** and passing backward through optical fiber **100**, and processing unit **330** is arranged to receive the intensity measurements from sensor **320** and estimate, by comparing intensity values of reflections **110** associated with two or more numerical aperture values, distance **125** between tissue **90** and distal end **120** of optical fiber **100**. Estimated distance **125** may serve as a proxy for the user of the system for enhancing the effective operation of the system.

[**0043**] Modulator **310** may control a collimated input beam **152** (**Figure 4**), to yield an input beam **151** with a varying beam diameter B_1 , B_2 on input optics **121** (e.g.

lens), resulting in different numerical aperture values of resulting light beam **150** at the focal point at the entrance to fiber **100**.

[0044] Alternatively, modulator **310** may comprise a beam steering device (not shown), arranged to periodically change an incidence location of light beam **150** upon input lens optics **121** of the optical fiber system at proximal end **120** of fiber **100**, to modulate the numerical aperture of light beam **150**. The beam steering device, controlled by modulator **310**, may move collimated light beam **151** upon the face of input lens **121** to change the range of entrance angles of light beam **150** into fiber **100**. **Figures 5A** and **5B** illustrate two positions of the beam steering device – in **Figure 5A** incoming beam **151A** is centered around optical axis **153** resulting in light beam **150A**, while in **Figure 5B** incoming beam **151B**, e.g. of the same diameter B , is off-center in respect to optical axis **153**, resulting in a larger entrance angle $\theta_2 > \theta_1$ and a larger numerical aperture of light beam **150** due to the fiber axial symmetry.

[0045] In one embodiment of the system, modulator **310** may comprise at least two laser sources emitting beams **151A**, **151B** with different numerical apertures NA_1 , NA_2 through input optics **121A**, **121B** (e.g. lenses with different focal lengths F_1 , F_2) respectively. A combiner **155** and an optical switch (not shown) that is controlled by modulator **310** may be used to provide alternately beams **151A**, **151B** as sources for light beams **150A**, **150B** respectively, having different numerical apertures, denoted in **Figure 6** by angles θ_1 and θ_2 .

[0046] Processing unit **330** may be arranged to derive the distance estimation from a ratio of reflection intensities at different numerical aperture. The optical characteristics of the target tissue may be considered more or less constant during the modulation period and measurements. The time constants for the modulating and the measuring may be selected to match the conditions under which **Equations 3** and **4** were derived.

[0047] Tissue distance estimator **301** may be part of a tissue treatment system **300**, that further comprises a treatment beam laser **80**, arranged to deliver energy via optical fiber **100** to target tissue **90**. In this case, estimated distance **125** may serve as a proxy for the physician to enhance treatment efficiency. Light beam **150** and treatment beam **80** may be separate beams and introduced into fiber **100** by combiner **156** (**Figure 3**), or light beam **150** and treatment beam **80** may origin from the same

source, e.g. from the same laser source. For example – the treatment may be applied in pulses with specific physical characteristics, while light beam **150** as measurement beam may be applied between the pulses with different physical characteristics. In another example, the treatment beam itself may be modulated and used as the measurement beam, for example in the case of a continuous wave treatment beam.

[0048] Modulator **310** and sensor **320** are arranged to carry out the modulation and the measurement (respectively) during interruption periods of treatment laser **80**. Treatment laser **80** may be pulsed, and modulator **310** and sensor **320** may be arranged to carry out the modulation and the measurement (respectively) between pulses of treatment laser **80**.

[0049] Light beam **150** used by tissue distance estimator **301** may be produced by treatment laser **80** and be, e.g. of low intensity, in contrast to the high intensity treatment beam.

[0050] Modulator **310** and sensor **320** are arranged to carry out the modulation and the measurement (respectively) during lasing interruptions of the laser **80**. The period between consecutive measurements must be shorten so that $F(t)$ would change as little as possible. Furthermore, the measurement period may be selected in relation to the applied treatment and the operationally required frequency of distance estimation.

[0051] Tissue treatment system **300** may further comprise an indicator **340** arranged to indicate the estimated distance by at least one of: an acoustic indication, a visual indication, and a vibratory indication.

[0052] The proposed modulation of numerical aperture allows differentiating the weaker reflection **110** that arrives to sensor **320** from the more intense reflections **91** and **99**. Moreover, by comparing successive reflections from target tissue **90** that result from light beams of varying numerical aperture, a crude assessment of distance **125** between target tissue **90** and distal fiber end **110** may be achieved. The invention utilizes the fact that mainly tissue reflections **110** respond differently to different numerical aperture values of light beam **150**.

[0053] In the above description, an embodiment is an example or implementation of the invention. The various appearances of "one embodiment", "an embodiment" or

"some embodiments" or "embodiments" do not necessarily all refer to the same embodiments.

[0054] Although various features of the invention may be described in the context of a single embodiment, the features may also be provided separately or in any suitable combination. Conversely, although the invention may be described herein in the context of separate embodiments for clarity, the invention may also be implemented in a single embodiment.

[0055] Furthermore, it is to be understood that the invention can be carried out or practiced in various ways and that the invention can be implemented in embodiments other than the ones outlined in the description above.

[0056] The invention is not limited to those diagrams or to the corresponding descriptions. For example, flow need not move through each illustrated box or state, or in exactly the same order as illustrated and described.

[0057] Meanings of technical and scientific terms used herein are to be commonly understood as by one of ordinary skill in the art to which the invention belongs, unless otherwise defined.

[0058] While the invention has been described with respect to a limited number of embodiments, these should not be construed as limitations on the scope of the invention, but rather as exemplifications of some of the preferred embodiments. Other possible variations, modifications, and applications are also within the scope of the invention.

CLAIMS

What is claimed is:

- . A method comprising:
 - modulating a numerical aperture of a light beam transmitted through an optical fiber and directed at a target tissue via a distal end of the optical fiber,
 - measuring intensity values of reflections of the light beam reflected from the target tissue and transmitted backward through the optical fiber, and
 - estimating, by comparing intensity values of the reflections associated with two or more numerical aperture values, a distance between the target tissue and the distal end of the optical fiber.
- . The method according to claim 1, wherein during specified periods, the light beam is a treatment beam and wherein the modulation is carried out during time periods other than the specified periods.
- . The method according to claim 1, wherein the light beam is a treatment beam and the modulation is carried out at least partially during treatment of the target tissue.
- . The method according to claim 1, further comprising transmitting a treatment beam with specified physical characteristics through the optical fiber to apply a specified treatment to the target tissue.
- . The method according to claim 4, wherein the treatment beam is applied during specified periods, and wherein the modulating of the light beam is carried out during time periods other than the specified periods, in which the light beam is a measurement beam.
- . The method according to claim 5, wherein the treatment beam is a pulsed laser and wherein the modulating is carried out between pulses of the pulsed laser.
- . The method according to claims 2 or 4, wherein the treatment beam is a continuous wave laser and wherein the modulating is carried out whenever the treatment beam is interrupted.
- . The method according to claims 2 or 5, wherein a modulation period of the measurement beam is selected to be shorter than a typical duration in which optical characteristics of the target tissue are constant.
- . The method according to claim 8, wherein the distance estimation is derived from a ratio of reflection intensities at different numerical apertures.
- 0. The method according to claim 1, wherein the modulating is carried out discretely over at least two numerical aperture values.

1. The method according to claim 10, wherein the modulation is binary and is carried out over two alternating numerical aperture values.
2. The method of claim 1, wherein the modulating is carried out continuously over a specified range of numerical apertures.
3. The method according to claim 10 or 12, wherein the modulating is carried out over a range within a maximal possible range between a numerical aperture of the optical fiber and a diffraction-limit of the optical fiber.
4. The method of claim 1, wherein the modulating is carried out by multiplexing at least two light beams each associated with a different numerical aperture.
5. The method of claim 1, wherein the modulating is carried out by moving the light beam in respect to an input optics, in a direction perpendicular to an optical axis of the input optics.
6. The method of claim 1, further comprising providing an indication of the estimated distance.
7. The method of claim 16, wherein the indication is at least one of: an acoustic indication, a visual indicator, and a vibratory indication.
8. The method according to any of claims 2 to 4, further comprising using the estimated distance to modify at least one of: the specified physical characteristics and the specified periods of the treatment beam application.
9. A tissue distance estimator comprising:
 - a modulator positioned at a proximal end of an optical fiber and arranged to modulate a numerical aperture of a light beam transmitted through the optical fiber and directed at a target tissue via a distal end of the optical fiber,
 - a sensor positioned at the proximal end of the fiber and arranged to measure intensity values of reflections of the light beam reflected from the target tissue and transmitted backward through the optical fiber, and
 - a processing unit arranged to receive the intensity measurements from the sensor and estimate, by comparing intensity values of the reflections associated with two or more numerical aperture values, a distance between the target tissue and the distal end of the optical fiber.
10. The tissue distance estimator of claim 9, wherein the modulator comprises at least two laser sources emitting beams with different numerical apertures and an optical switch arranged to alternate the beams as sources for the light beam.

1. The tissue distance estimator of claim 19, wherein the modulator comprises a beam steering device, arranged to periodically change an incidence location of the light beam in respect to an optical axis of an input optics of the optical fiber at the proximal end of the fiber, to modulate the numerical aperture of the light beam.
2. The tissue distance estimator of claim 19, wherein the modulator is arranged to change an incidence beam diameter of the light beam upon an input optics at the proximal end of the fiber, to modulate the numerical aperture of the light beam.
3. The tissue distance estimator of claim 19, wherein the processing unit is arranged to derive the distance estimation from a ratio of reflection intensities at different numerical apertures.
4. A tissue treatment system comprising:
 - a treatment laser, arranged to treat the target tissue by delivering energy via the optical fiber to the tissue, and
 - the tissue distance estimator of any of claims 19 to 23,
 - wherein the modulator and the sensor are arranged to carry out the modulation and the measurement (respectively) during interruptions in the treatment.
5. The tissue treatment system of claim 24, wherein the treatment laser is a source of the light beam, and wherein the modulation is carried out during the interruptions in the treatment.
6. The tissue treatment system of claim 24, wherein the treatment laser is a source of the light beam, and wherein the modulation is carried out at least partly during the treatment.
7. The tissue treatment system of claim 24, further comprising a source of the light beam other than the treatment laser.
8. The tissue treatment system of claim 24, wherein the treatment laser is pulsed, and the modulator and the sensor are arranged to carry out the modulation and the measurement (respectively) between pulses of the treatment laser.
9. The tissue treatment system of claim 24, further comprising an indicator arranged to indicate the estimated distance by at least one of: an acoustic indication, a visual indication, and a vibratory indication.
0. The tissue treatment system of claim 24, wherein the processing unit is further arranged to modify physical characteristics and treatment periods of the treatment beam according to predefined rules.

1/5

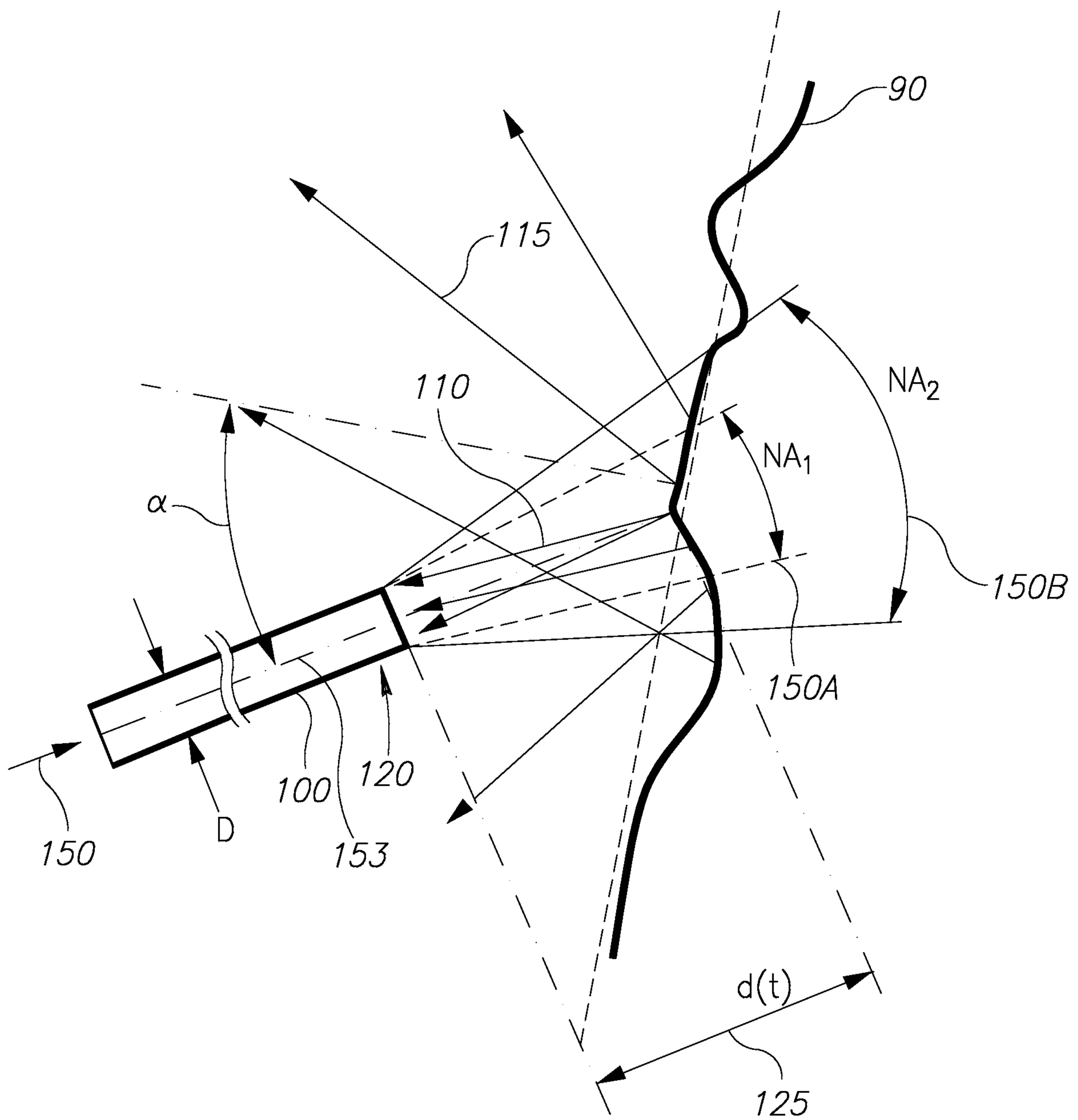


Figure 1

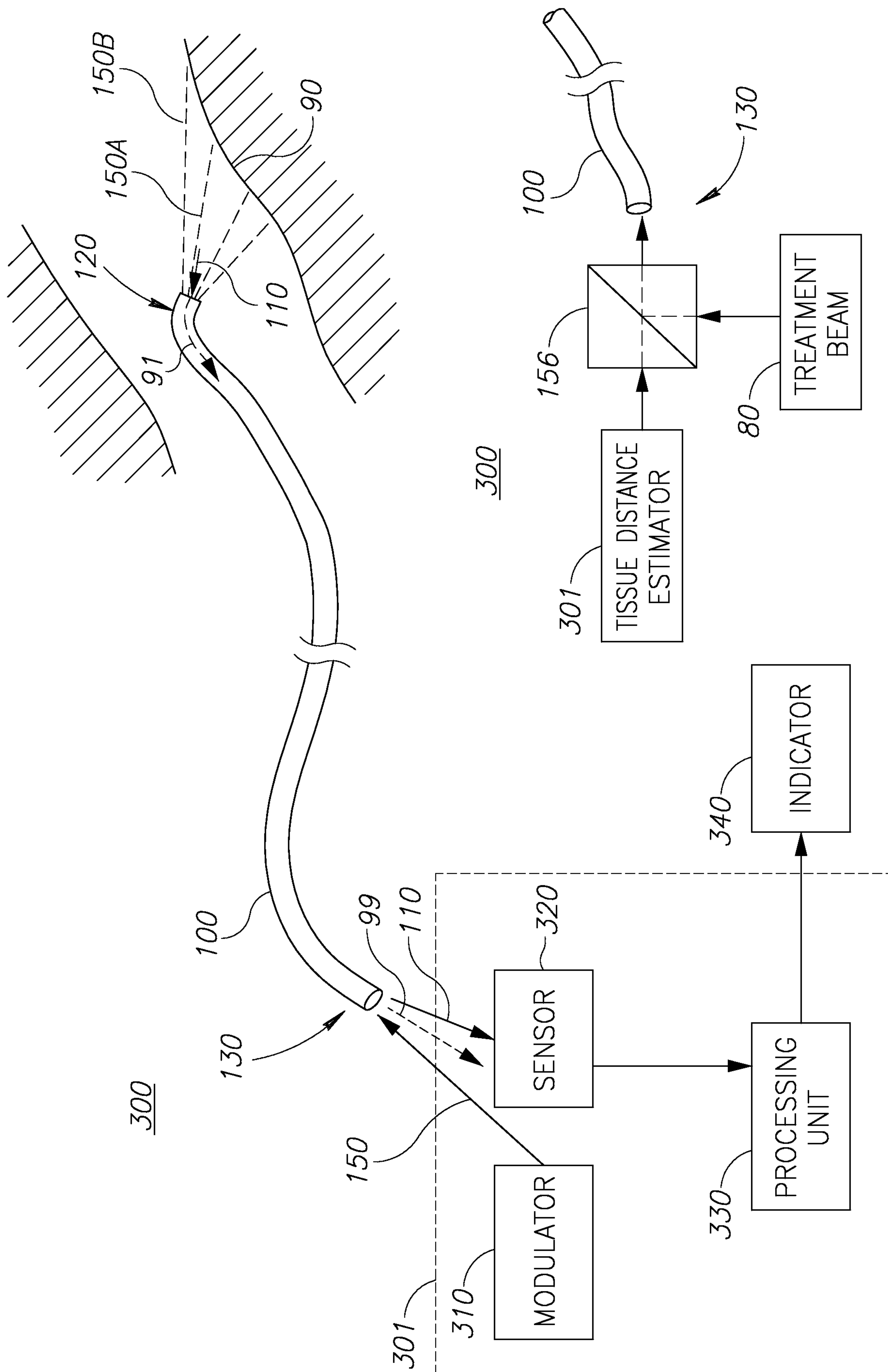


Figure 3

Figure 2

3/5

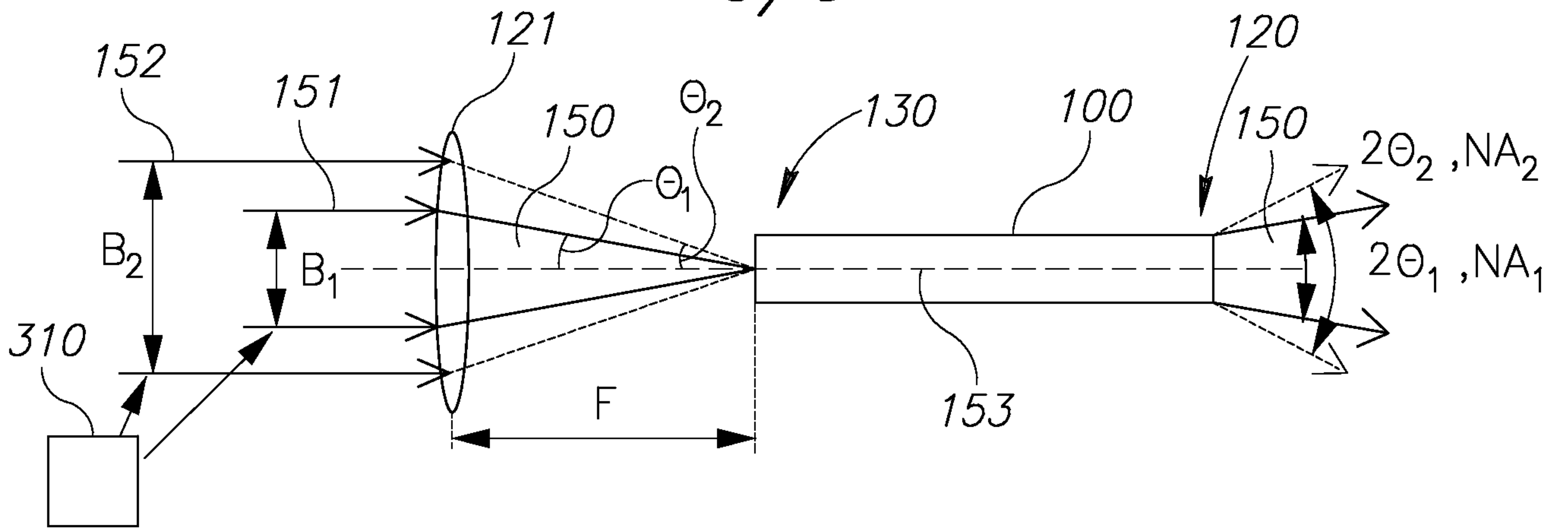


Figure 4

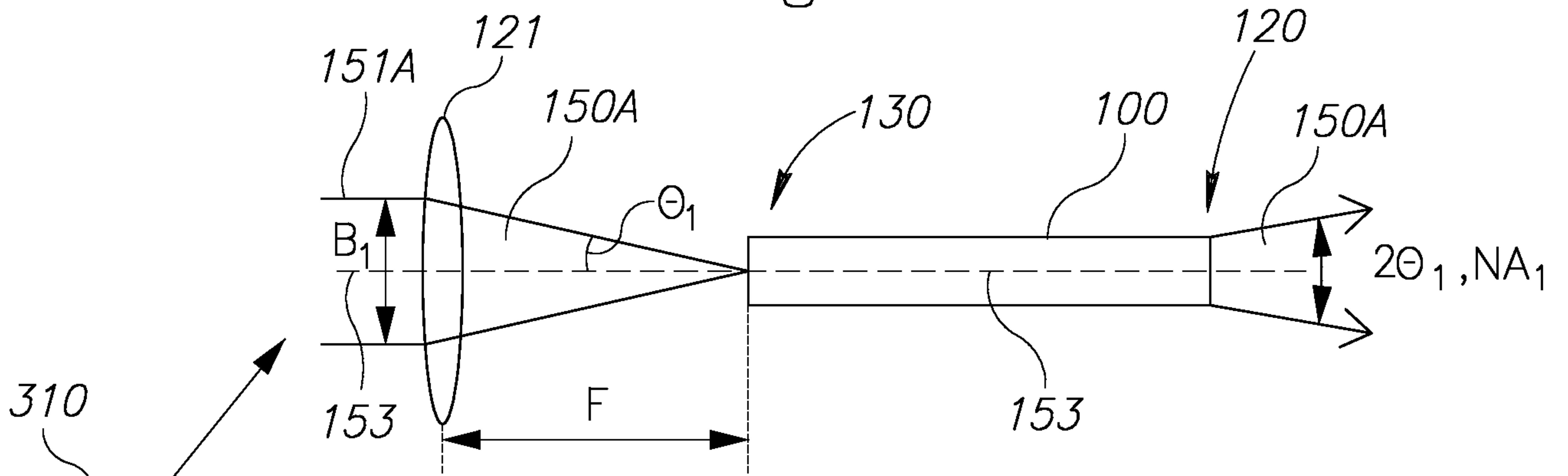


Figure 5A

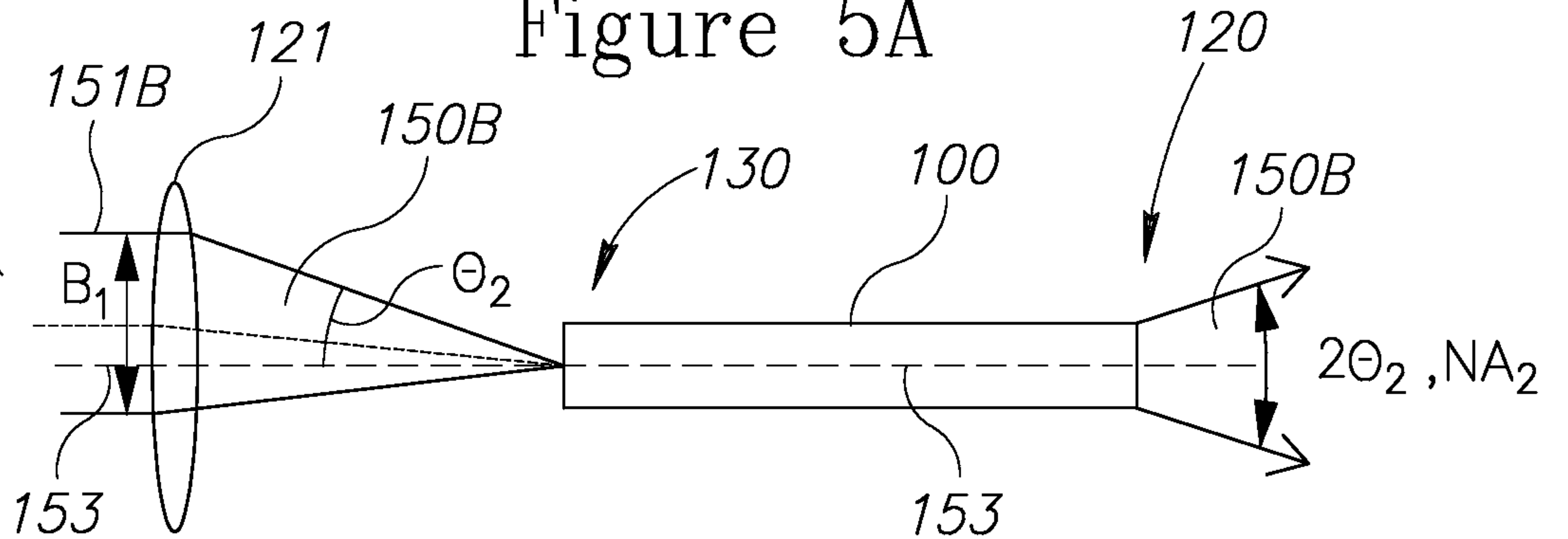


Figure 5B

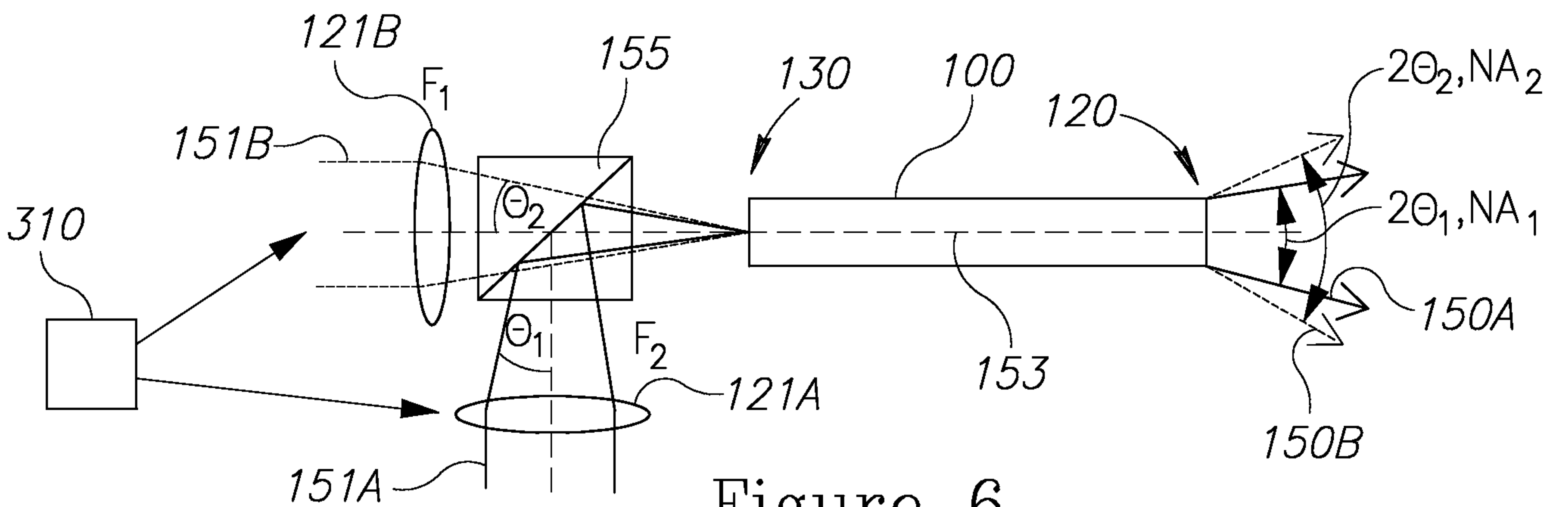


Figure 6

4/5

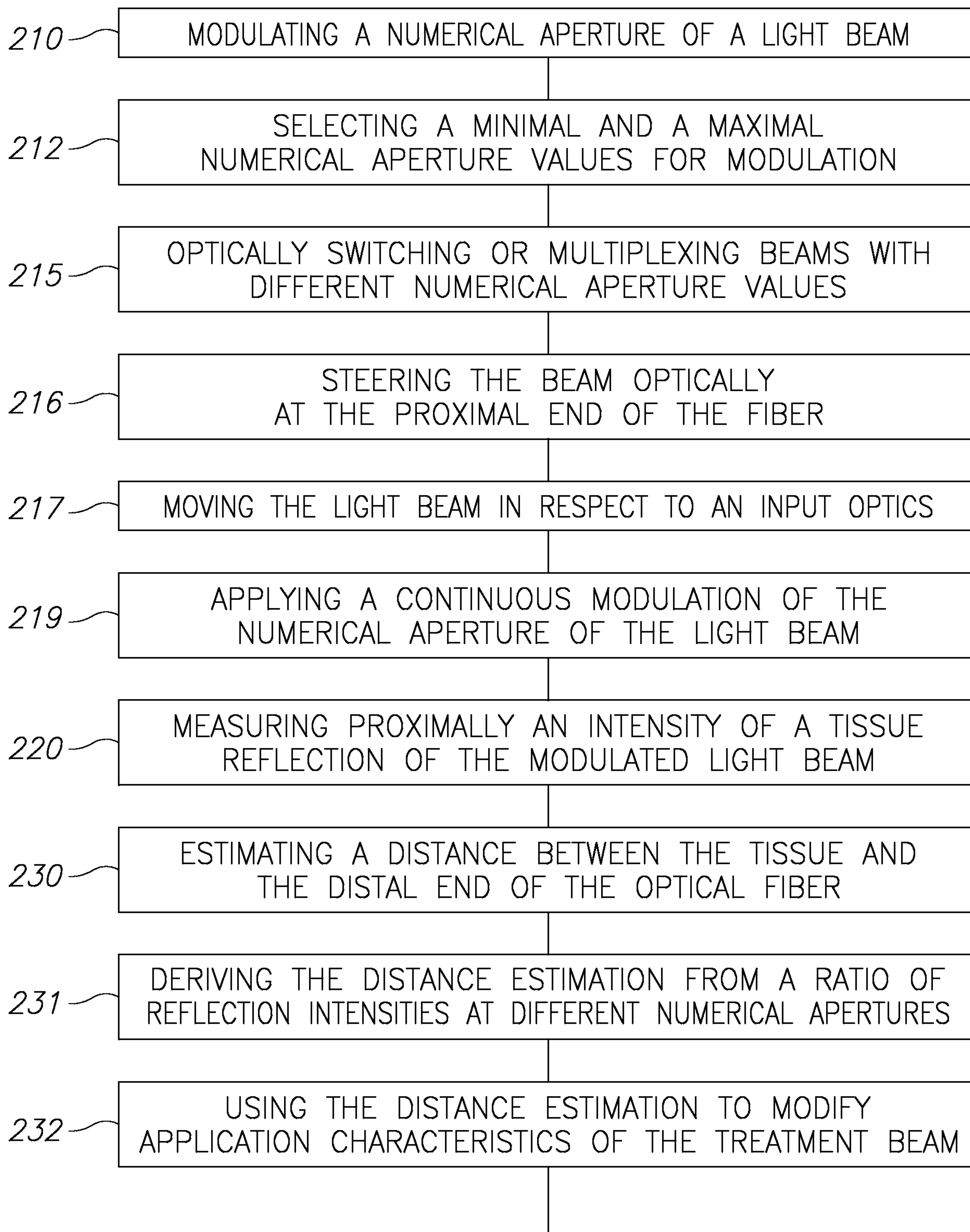
200

Figure 7

5/5

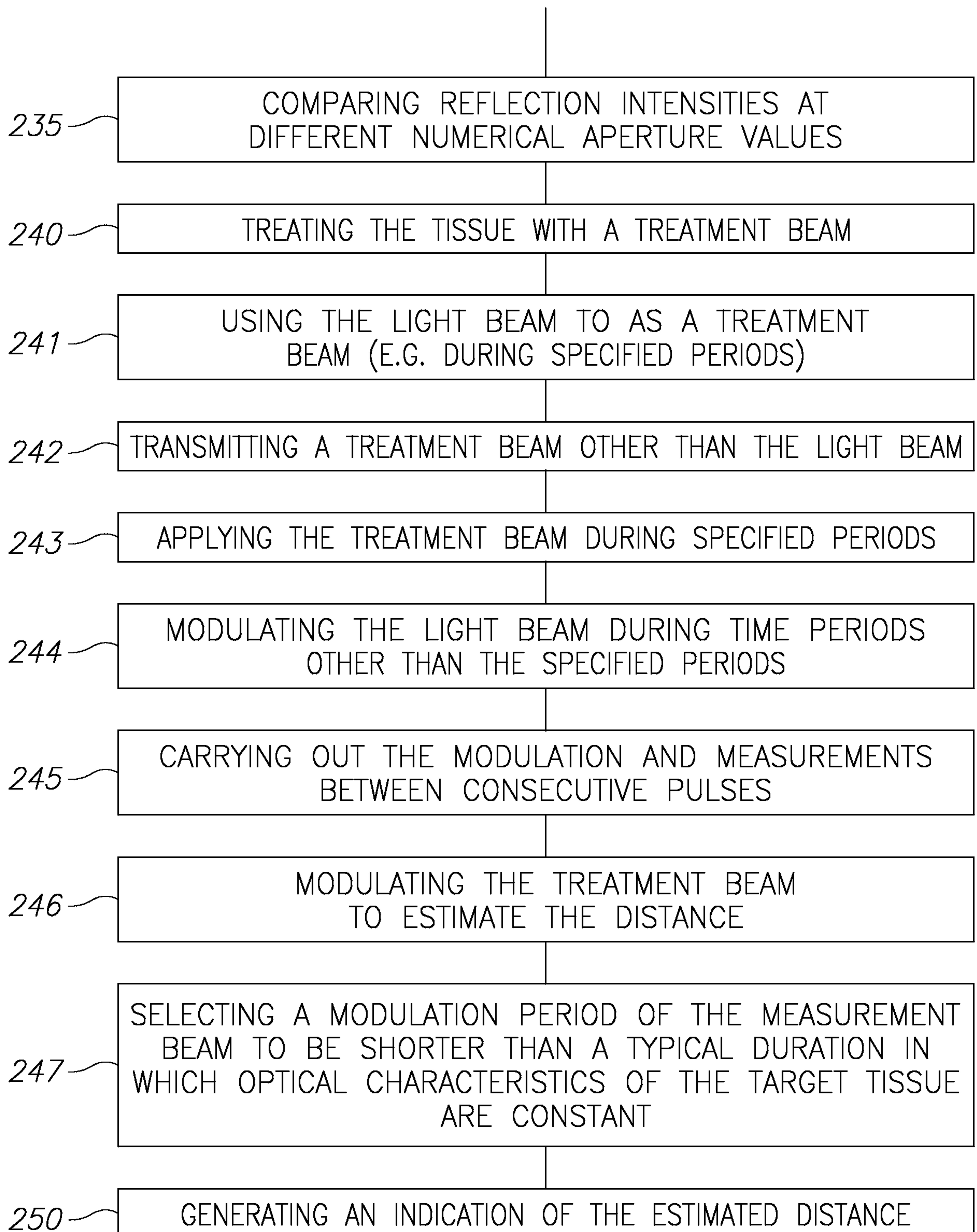


Figure 7 cont.

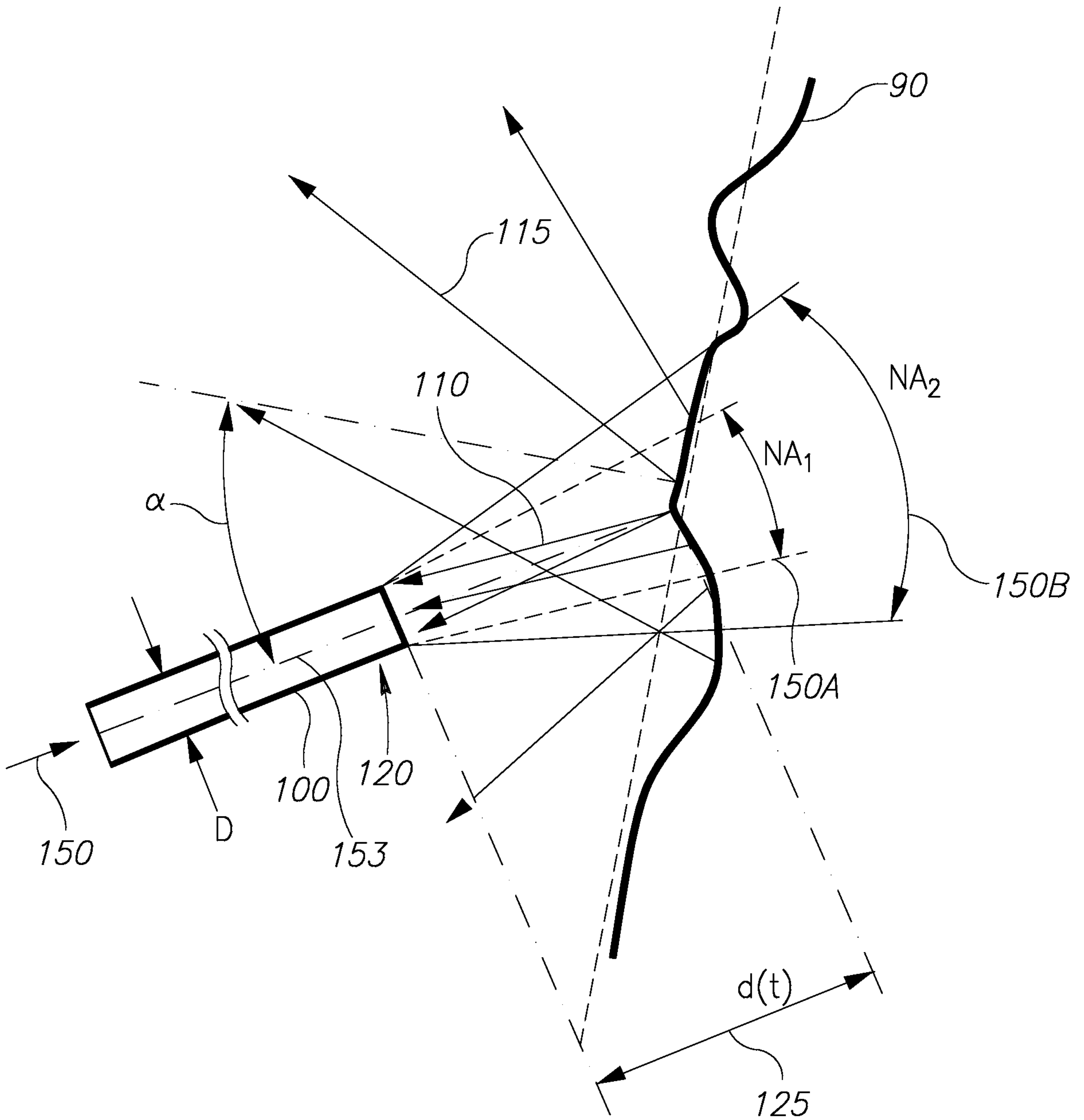


Figure 1