



(12) EUROPEAN PATENT APPLICATION

(43) Date of publication:
13.06.2001 Bulletin 2001/24

(51) Int Cl.7: H04Q 7/38

(21) Application number: 00308081.9

(22) Date of filing: 18.09.2000

(84) Designated Contracting States:
AT BE CH CY DE DK ES FI FR GB GR IE IT LI LU
MC NL PT SE
Designated Extension States:
AL LT LV MK RO SI

- Roberts, M.
Prittlewell, Essex SS2 5EB (GB)
- Sivagnanasundaram, S.
Tooting, London SW17 4EJ (GB)
- Jarvis, A. W.
Tetbury, Gloucestershire GL8 8HB (GB)

(30) Priority: 10.12.1999 EP 99309979

(71) Applicant: LUCENT TECHNOLOGIES INC.
Murray Hill, New Jersey 07974-0636 (US)

(74) Representative:
Buckley, Christopher Simon Thirsk et al
Lucent Technologies (UK) Ltd,
5 Mornington Road
Woodford Green, Essex IG8 0TU (GB)

(72) Inventors:
• Costa, M.
Chippenham, Wiltshire SN5 6PP (GB)

(54) Packet switched mobile radio telecommunications system with more effective hard handover

(57) In a packet switched mobile radio telecommunications system such as UMTS or GSM, on hard handover of a mobile 18 a target RNC 24 requests a direct link 36 to a serving controller 22, which sends up-

link frames from the mobile 18 both to the TRNC 24 and to the core network 10; the core network 10 sends down-link frames to the TRNC 24. The TRNC decides when to complete the handover, and rebuilds frames when necessary.

FIG. 3

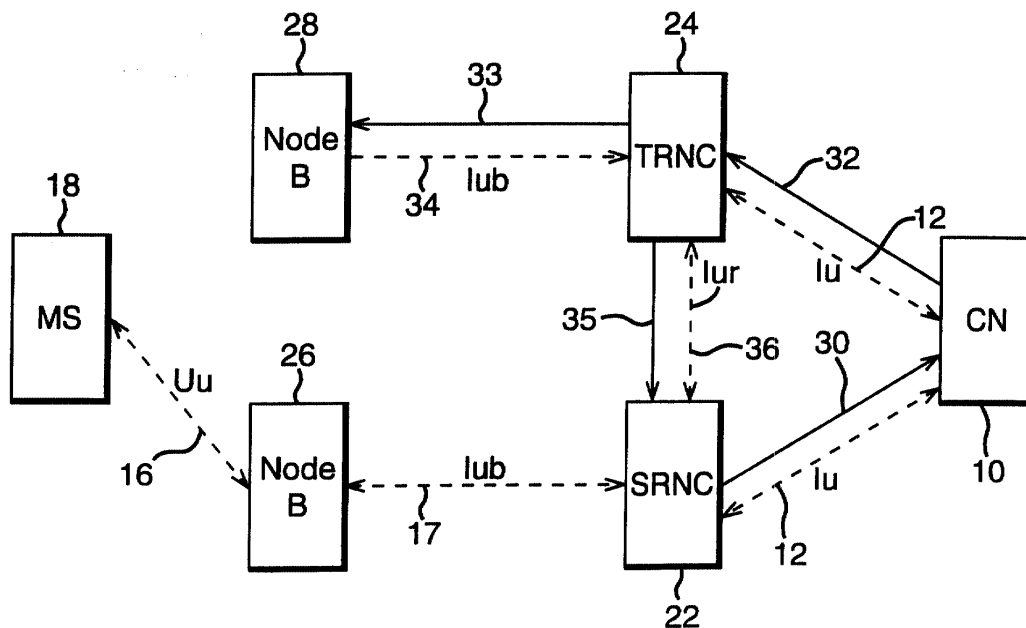

Description

[0001] This invention relates to a mobile radio telecommunications system such as the Universal Mobile Telephone System (UMTS) or the Global System for Mobile communications (GSM), operating on a packet switching principle, and relates especially to the arrangements made for hard handover in such a system.

[0002] As a mobile user moves over the ground, handover of the mobile from one radio channel to another, i.e. from one network controller to another, is a frequent requirement. As the mobile leaves the old channel and attaches to the new channel side, the disconnection and reconnection lead to a break in the path and loss of data frames, both uplink and downlink, on the radio interface. There is thus a degradation of radio performance.

[0003] It is an object of the invention to provide hard handover arrangements in which the break in connection to a mobile is smaller/shorter, thus improving performance.

[0004] According to the invention, in a packet switched mobile radio telecommunications system a method of handing over control of a mobile system from a serving controller to a target controller in which the serving controller sends a handover request message to the core network and the core network sends a handover required signal to the target controller, characterized by the further steps of:-

- the target controller requesting a direct link to the serving controller;
- the serving controller sending uplink frames from the mobile system to the target controller over said direct link and simultaneously sending these frames to the core network;
- the core network sending downlink frames for the mobile system to the target controller and to the serving controller;
- and the target controller deciding when to complete the handover and sending a handover command signal to the serving controller via the core network..

[0005] Also according to the invention a controller for a packet switched mobile radio telecommunications system characterized by being arranged so that, on receipt from a core network of the system of a handover required message related to a mobile system, the controller sends to the controller currently serving the mobile system a request for a direct link.

[0006] The invention will now be described by way of example only with reference to the accompanying drawings in which:-

- Figure 1 illustrates schematically a part of a packet switched mobile radio telecommunications network, (the UMTS); and
- Figures 2, 3, 4 and 5 illustrate four stages in a hard

handover according to the invention.

[0007] In Figure 1, a Core Network (CN) 10 has an interface 12, the Iu interface, to the UMTS Terrestrial Radio Access Network (UTRAN) 14, and the UTRAN 14 has an interface 16, the Uu interface, to a number of Mobile Systems (MSs) 18, 20.

[0008] Within the UTRAN 14 are a number of Radio Network Controllers (RNC) 22, 24, two only being illustrated, each RNC controlling a number of Node Bs 26, 28, two only being shown for each RNC. Each Node B is connected to its RNC by an Iub link 17. RNC 22 controls the MSs 18, 18' through Node Bs 26 and RNC 24 controls the MSs 20 through Node Bs 28 .

[0009] In the Figure, the network is the UMTS network; in a GSM network the equivalent building block to an RNC is termed a Base Station Controller (BSC); a Node B is termed a Base Transceiver Station (BTS); and the Uu interface is termed the radio interface.

[0010] The RNCs 22, 24 build frames containing data, send the frames to a Node B 26, 28 and control a mobile system as it moves over the ground. A Node B receives frames from an RNC, and modulates the data for passage to the radio interface Uu 16 and thence to a mobile.

[0011] The UMTS is arranged to have a control plane and a user plane; the control plane is arranged to control signalling between Node Bs and RNCs, to control the allocation of requests for resources, and to control handover requests. The user plane is responsible for handling the actual data.

[0012] Suppose one of the mobile systems 18 moves upwards in Figure 1 as shown by the Arrow M, so that control of the MS 18 must pass from a Node B 26 controlled by RNC 22 to a Node B 28 controlled by RNC 24.

The first step is illustrated in Figure 2, in which the Iu interface 12, the Uu interface 16, and the Iub link 17 between the RNCs and the Node Bs are indicated by double-headed dotted arrows. The serving RNC 22 sends a handover request signal 30 to CN 10 over the Iu interface 12. As shown in Figure 3, the CN 10 sends a handover required signal 32 over the Iu interface 12 to the target RNC 24, and in response the TRNC 24 sends a command signal 33 which sets up an Iub link 34 to the Node B 28. The TRNC 24 also sends a command signal 35 setting up an Iur link 36 between TRNC 24 and SRNC 22.

[0013] For a smooth handover of the MS 18, the SRNC 22 must connect the appropriate MS through the TRNC 24; a reference is used, which may be the actual MS identity or a reference allocated to the MS 18 by the SRNC 22 while that mobile is under its control. This reference is supplied by the SRNC 22 to the TRNC 24 over the Iur link 36.

[0014] On supply of the reference, the TRNC 24 receives uplink frames from MS 18 on the serving channel side via Node B 26 and SRNC 22 while the SRNC 22 simultaneously sends uplink frames to CN 10. The downlink frames are supplied by the CN 10 on the Iu

interface 12.

[0015] The TRNC 24 can now decide how to rebuild the frames from MS 18 when disconnection and reconnection occur on the radio interface, and then sends a handover command signal 38 to the SRNC 22 via the CN 10, as shown in Figure 4. The MS 18 disconnects from the old channel and connects to the new channel over the Uu link 16 to Node B 28, as shown in Figure 5. The frames received on the old channel and on the new channel are both received by the TRNC 24, thus the break in the user plane path is substantially reduced, and can be regarded as almost seamless.

[0016] In previous arrangements the CN was in control of the handover, but was forced to operate on signalling which was delayed; the CN was therefore unable to determine whether a frame had been repeated. By application of the invention, the risk of repeated frames is much reduced and handover is more effective.

Claims

1. In a packet switched mobile radio telecommunications system, a method of handing over control of a mobile system (18) from a serving controller (22) to a target controller (24) in which the serving controller (22) sends a handover request message (30) to the core network (10) and the core network sends a handover required message (32) to the target controller, characterized by the further steps of:-

the target controller (24) requesting (35) a direct link (36) to the serving controller (22);
 the serving controller (22) sending uplink frames from the mobile system (18) to the target controller (24) over said direct link (36) and simultaneously sending these frames to the core network (10);
 the core network (10) sending downlink frames for the mobile system (18) to the target controller (24) and to the serving controller (22) simultaneously;
 the target controller (24) deciding when to complete the handover; and
 the target controller (24) sending a handover command signal (38) to the serving controller (22) via the core network (10).

2. A method according to Claim 1 in which said direct link is an Iur link 36.
3. A method according to Claim 1 or Claim 2 in which the target controller (24) rebuilds frames received from and addressed to the mobile system (18) before sending the handover command signal (38).
4. A method according to any one of Claims 1, 2 or 3 in which the serving controller (22) sends to the tar-

get controller (24) the identity of the mobile system (18).

5. A method according to any one of Claims 1, 2 or 3 in which the serving controller (22) sends to the target controller (24) a reference allocated to the mobile system (18) by the serving controller (22).
6. A method according to any preceding claim in which the serving and target controllers are radio network controllers (22, 24).
7. A controller (22, 24) for a packet switched mobile radio telecommunications system characterized by being arranged so that, on receipt from a core network (10) of the system of a handover required message (32) related to a mobile system (18), the controller (24) sends to the controller (22) currently serving the mobile system (18) a request for a direct link.
8. A controller according to Claim 7 in which the direct link is a Iur link (36).
9. A controller according to Claim 7 or Claim 8 further arranged to receive uplink frames from controller (22) currently serving the mobile system (18), to receive downlink frames from a core network (10) of the system, to decide when to complete the handover of the mobile system (18), and to send a handover command signal (38).
10. A controller according to Claim 9 further arranged to rebuild frames received from and addressed to the mobile system (18) before sending the handover command signal (38).
11. A controller for a packet switched mobile radio telecommunications system characterized by being arranged so that, on receipt of a request from a target controller (22) the controller (24) sets up a direct link (36) to the target controller (22), and sends uplink frames from a mobile system (18) to be handed over to the target controller (22) and to the core network (10) of the system simultaneously.
12. A controller (24) according to Claim 11 further arranged to send to the target controller (22) the identity of the mobile system (18).
13. A controller (24) according to Claim 11 further arranged to send to the target controller (22) a reference allocated to the mobile system (18) by the controller (22).
14. A controller according to any one of claims 7 to 13 in which the telecommunications systems in the Universal Mobile Telephone System and the con-

troller (22, 24) is a radio network controller.

15. A controller according to any one of claims 7 to 13 in which the telecommunications system is the Global System for Mobile communications and the controller (22, 24) is a Base Station Controller.

5

10

15

20

25

30

35

40

45

50

55

FIG. 1

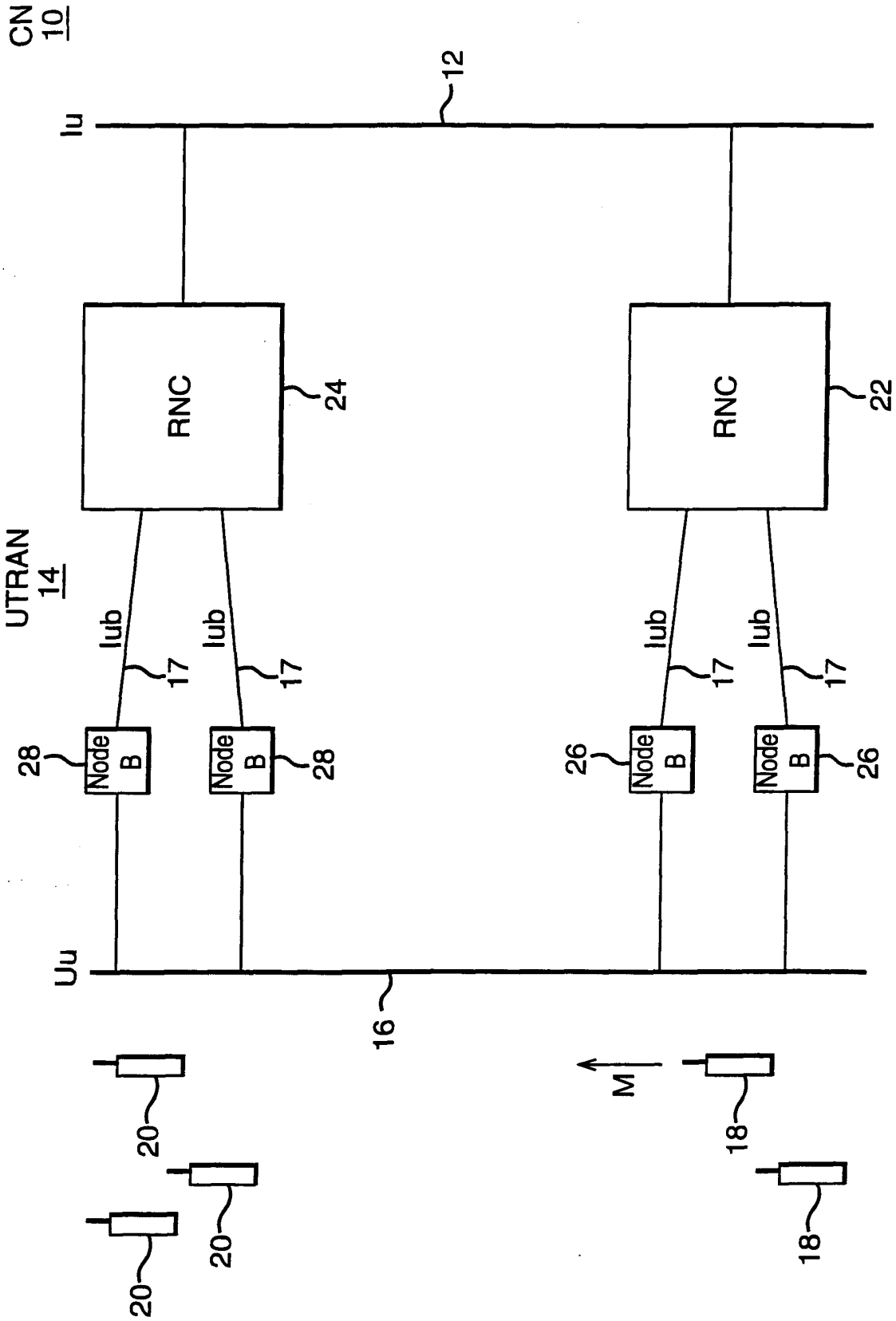

FIG. 2

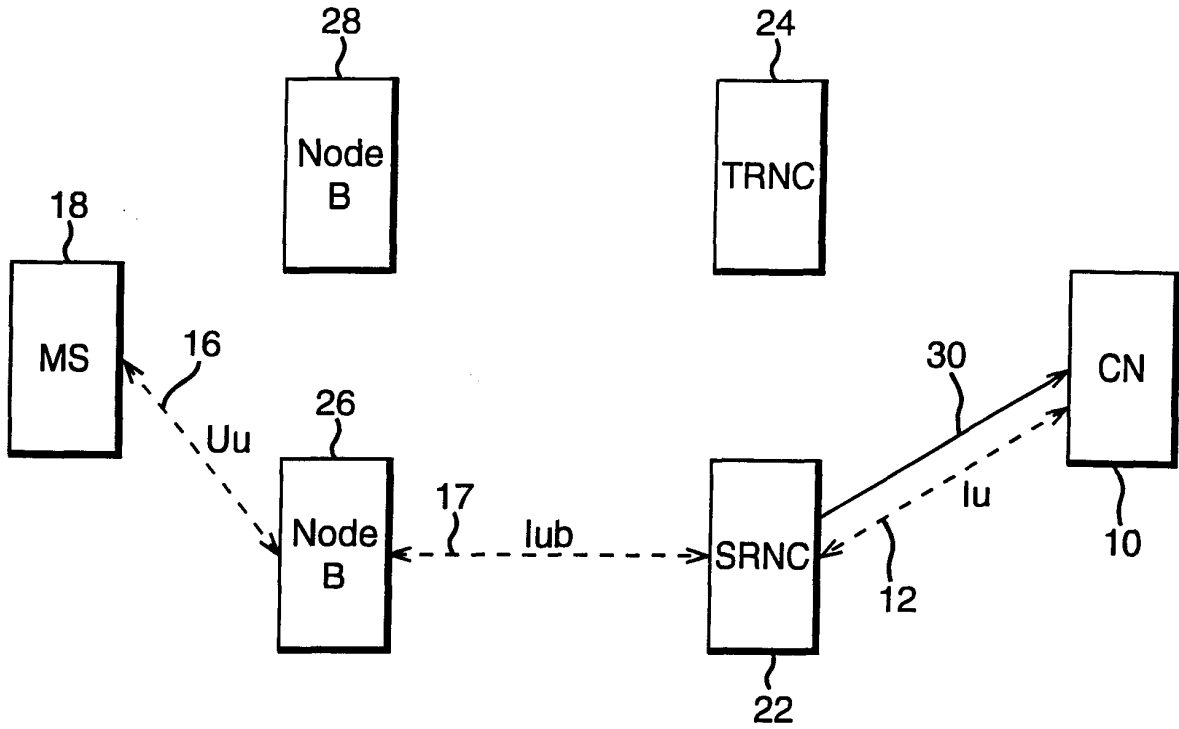

FIG. 3

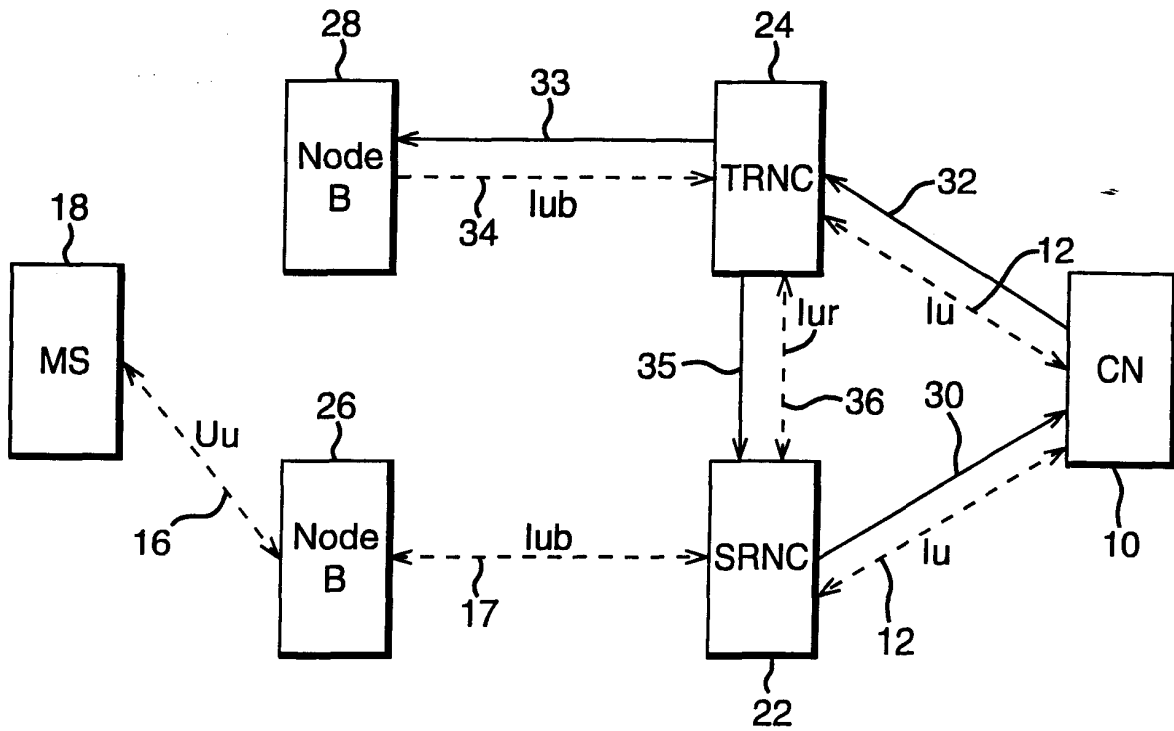

FIG. 4

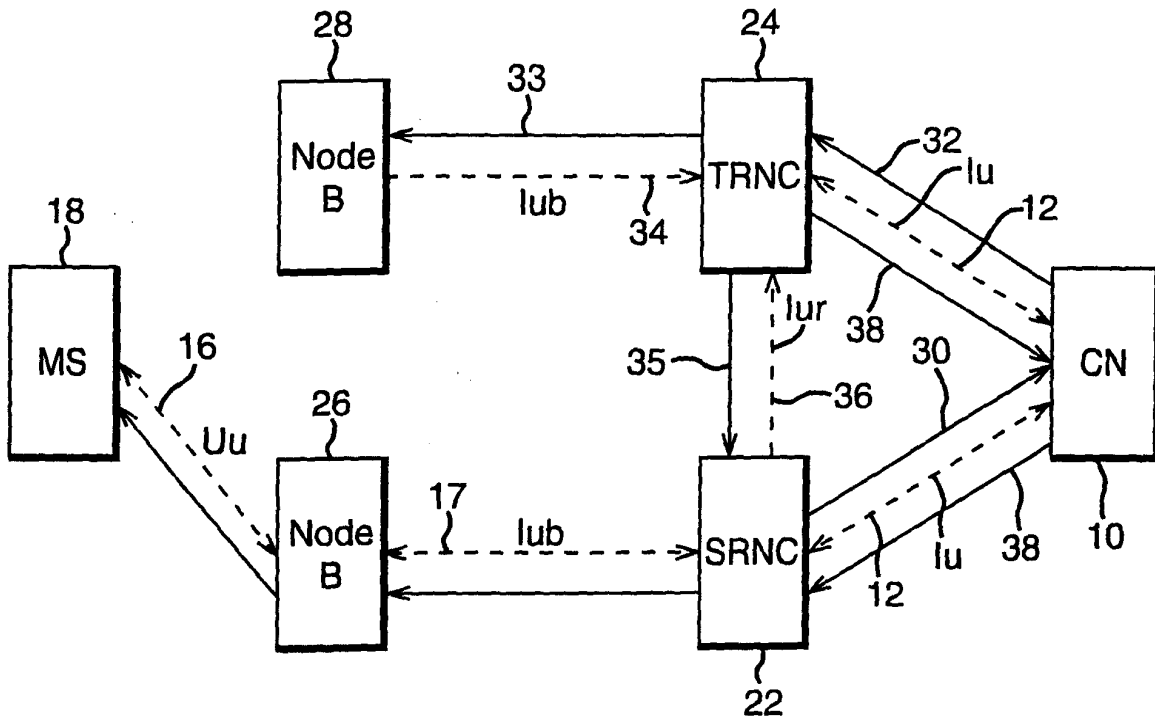
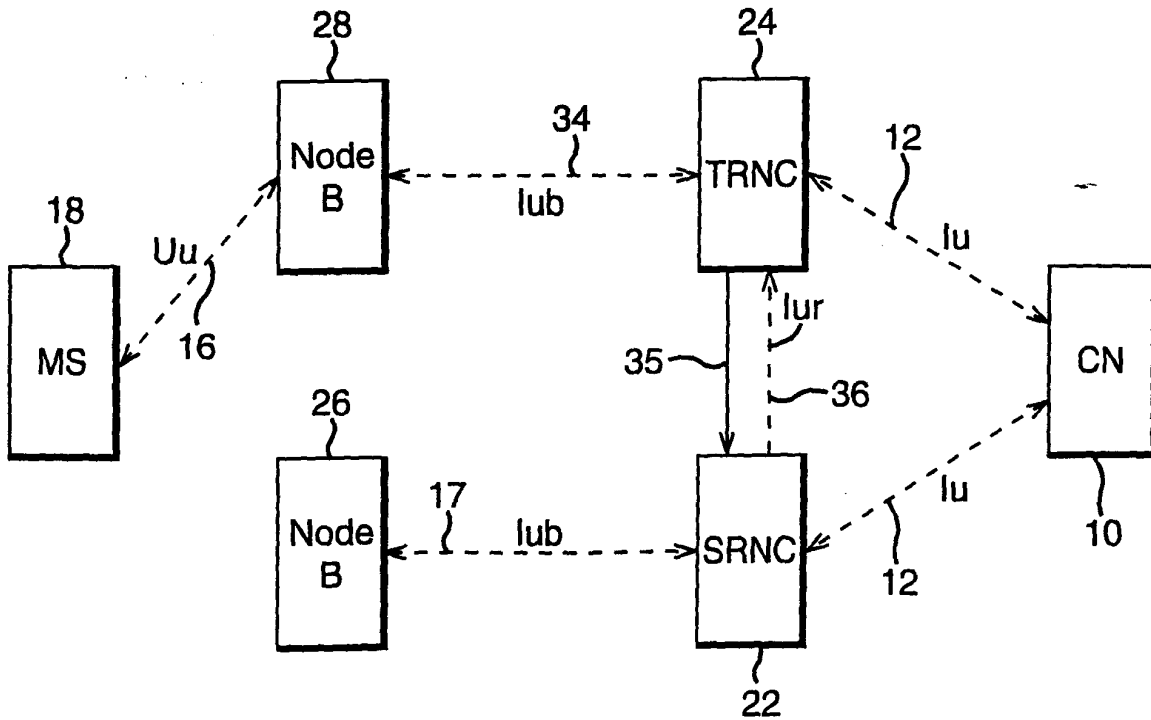

FIG. 5





European Patent
Office

EUROPEAN SEARCH REPORT

Application Number
EP 00 30 8081

DOCUMENTS CONSIDERED TO BE RELEVANT			
Category	Citation of document with indication, where appropriate, of relevant passages	Relevant to claim	CLASSIFICATION OF THE APPLICATION (Int.Cl.7)
X	WO 99 51051 A (NOKIA TELECOMMUNICATIONS OY ;AHMAVAARA KALLE (FI)) 7 October 1999 (1999-10-07) * page 5, line 12-27 * * page 6, line 14-16 * * page 7, line 1-5 * * page 8, line 16-20 * * page 8, line 33-36 * * page 9, line 18-24 * * page 10, line 11-27 * * page 14, line 23-29 *	1-15	H04Q7/38
A	WO 99 27740 A (ERICSSON TELEFON AB L M) 3 June 1999 (1999-06-03) * page 9, line 3 - page 10, line 3 * * page 12, line 14 - page 17, line 14; figures 4-6 *	1-15	
			TECHNICAL FIELDS SEARCHED (Int.Cl.7)
			H04Q
The present search report has been drawn up for all claims			
Place of search THE HAGUE		Date of completion of the search 6 April 2001	Examiner Janyszek, J-M
CATEGORY OF CITED DOCUMENTS X : particularly relevant if taken alone Y : particularly relevant if combined with another document of the same category A : technological background O : non-written disclosure P : intermediate document		T : theory or principle underlying the invention E : earlier patent document, but published on, or after the filing date D : document cited in the application L : document cited for other reasons & : member of the same patent family, corresponding document	

EPO FORM 1503 03.82 (P04001)

**ANNEX TO THE EUROPEAN SEARCH REPORT
ON EUROPEAN PATENT APPLICATION NO.**

EP 00 30 8081

This annex lists the patent family members relating to the patent documents cited in the above-mentioned European search report. The members are as contained in the European Patent Office EDP file on
The European Patent Office is in no way liable for these particulars which are merely given for the purpose of information.

06-04-2001

Patent document cited in search report	Publication date	Patent family member(s)	Publication date
WO 9951051 A	07-10-1999	FI 980736 A	01-10-1999
		AU 3149699 A	18-10-1999
		BR 9909307 A	21-11-2000
		EP 1068757 A	17-01-2001
WO 9927740 A	03-06-1999	AU 1358999 A	15-06-1999
		BR 9815113 A	10-10-2000
		CN 1284249 T	14-02-2001
		EP 1034679 A	13-09-2000

EPO FORM P0459

For more details about this annex : see Official Journal of the European Patent Office, No. 12/82