

L. C. A. J. GUYOT D'ARLINCOURT.  
RELAY MAGNET.

No. 105,653.

Patented July 26, 1870.

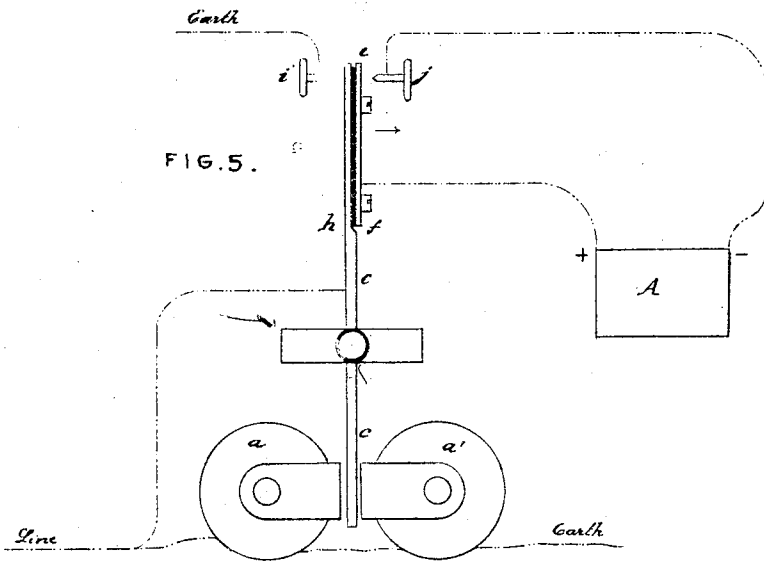
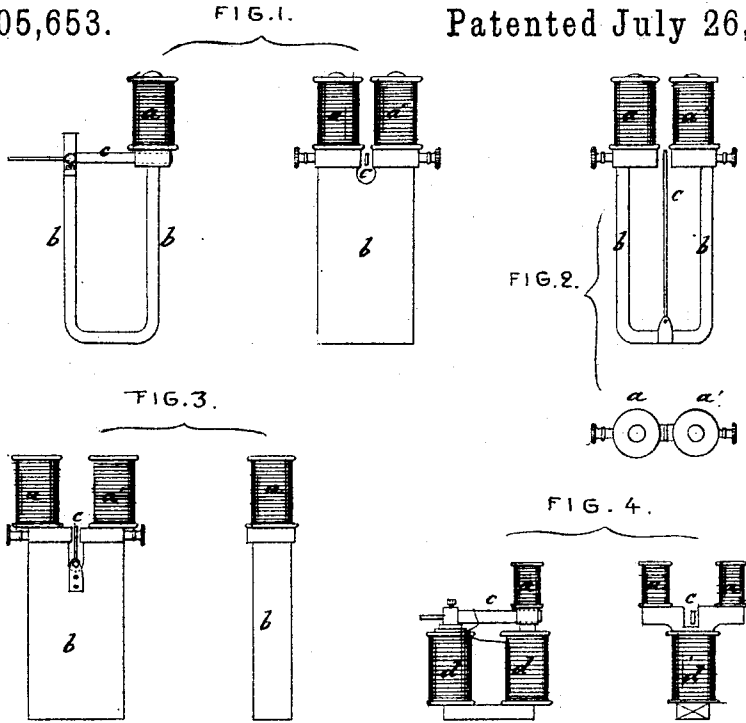

Witnesses:  
1. *Cuzius*  
2. *Em. Dubauz*

Inventor:  
*L. Guyot d'Arincourt*

# United States Patent Office.

LUDOVIC CHARLES ADRIEN JOSEPH GUYOT D'ARLINCOURT, OF PARIS.  
FRANCE

Letters Patent No. 105,653, dated July 26, 1870.

## IMPROVEMENT IN RELAY MAGNETS.

The Schedule referred to in these Letters Patent and making part of the same.

To all whom it may concern :

Be it known that I, LUDOVIC CHARLES ADRIEN JOSEPH GUYOT D'ARLINCOURT, of Paris, France, have invented new and useful Improvements in Electro-Magnets; and I do hereby declare that the following is a full, clear, and exact description thereof, which will enable others skilled in the art to make and use the same, reference being had to the accompanying drawing forming part of this specification.

My invention relates to improvement in arrangements of electro-magnets in telegraphic apparatus, and has special reference to the construction or peculiar disposition of an armature pallet, when the same must serve as a relay, as hereinafter fully set forth.

In the accompanying drawing—

Figures 1 to 4 represent various arrangements or modifications of a certain plan of arrangement of ordinary electro-magnets, through which a permanent current would pass.

Figure 5 is a plan view of the same, with a pallet constructed and arranged according to my invention.

Similar letters of reference indicate corresponding parts.

*a a'* represent ordinary electro-magnetic coils or spools, whose core or nucleus is made of soft iron.

*b* represents a natural magnet, connected with the coils *a a'* in such manner that the soft-iron cores of the said coils form the continuance of the magnet *b*.

*c* represents the pallet, the oscillating pivot of which works on the magnet *b*, but its free end is set toward the point of junction of the coils with the said magnet *b*.

Fig. 4 shows two coils, *d d*, substituted in place of the natural magnet *b*. In this case, a permanent current passes through the said coils *d*, so as to magnetise their soft-iron core or nucleus.

When a current shall be transmitted in one direction through the coils *a a'*, such a current will, for instance, cause the coil *a* to draw the pallet *c*, while the coil *a'* will repel it, and, as soon as such a current will be broken, the presence of the natural magnet *b*, or its equivalent, the coils *d d*, will generate a magnetic current in a direction opposite to that of the

transmitted current, whereby the coil *a* is made to repel, while the coil *a'* will attract the pallet *c*.

An electro-magnet of the above-described system, may be used for reversing the line current of a telegraphic apparatus, either as a transferring relay to transmit a new battery on the line, or as a single relay having charge to decompose the paper at the receiver within autographic telegraphic apparatus, by a local battery which is caused to work by the said relay.

Fig. 5 represents the construction or peculiar disposition of the armature pallet, when the latter must serve as a relay.

*ef* represent an insulated piece of the pallet *c*, which works between the electro-magnets *a a'*, as before described.

The portion *ef* of the pallet produces the communication with the local battery *A*, while the other portion, *gh*, of the pallet, produces the communication with the ground, to discharge the line. I actually cause the line to communicate before it enters the coils *a a'* with the portion *gh* of the pallet, when such portion *gh* is in contact with the screw *i*. This is the case when there is a current in the coils.

The pallet *c* will act as a "trembler" while the current lasts, thereby preventing the charging of the line and coils. When the current ceases, the pallet will travel in the direction of the arrow, and the portion *ef* will be in contact with the screw *j*. The local current will thereby be cut off, and may perform any required or desired function.

It will be seen that such disposition has a great importance, since it enables the continuous operation, while the current passes over the line.

Having thus described my invention,

I claim as new and desire to secure by Letters Patent—

The pallet *c*, provided with the insulated portion *ef*, substantially as and for the purpose herein shown and described.

L. GUYOT D'ARLINCOURT.

Witnesses:

CAZESUS,  
EM. DUHAN.