

(21) Application No 8414432

(22) Date of filing 6 Jun 1984

(30) Priority data

(31) 501953 (32) 7 Jun 1983 (33) US

(51) INT CL⁴
B65B 7/20

(52) Domestic classification
B8C U27

(56) Documents cited
None

(58) Field of search
B8C
B5D

(71) Applicants
Earle Conrad Sherman,
Route 9, Box 218, West Monroe, Louisiana 71291, United States of America
James Burd Peale Green, Jr.
319 Shady Oaks Drive, West Monroe, Louisiana 71291, United States of America

(72) Inventors
Earle Conrad Sherman,
James Burd Peale Green Jr

(74) Agent and/or Address for Service
Eric Potter & Clarkson,
14 Oxford Street, Nottingham NG1 5BP

(54) Sleeve carton end panel and flap folding and sealing assembly

(57) In a machine for packaging a plurality of articles within a sleeve carton comprising a top panel (26), a bottom panel (28), a pair of side panels (30,32), a dust flap (34-40) hinged to each end of each side panel, an upper end panel (46,48) hinged to each end of said top panel, and a lower end panel (42,44) hinged to each end of said bottom panel, a conveyor moves said sleeve cartons through said machine, folders (72,74) fold said dust flaps inward toward each other after said sleeve cartons have been loaded with articles, glue guns (78) apply adhesive to outer surfaces of said dust flaps after said dust flaps have been folded inward, and folding and sealing means (76,80,82,98) folds said upper and lower end panels against said dust flaps and presses said end panels against said dust flaps while said adhesive sets to seal said carton, said end panel folding means including a pair of lower folding plates (84) mounted directly opposite each other on either side of and adjacent said conveyor, driven cranks (88) for moving said lower folding plates in unison in an upward and downstream direction to fold said lower end panels up against said dust flaps, a pair of upper folding plates (90) mounted above said lower folding plates and directly opposite each other on either side of and adjacent said conveyor, and driven cranks (94) for moving said upper folding plates in unison in a downward and downstream direction to fold said upper end panels down against said dust flaps.

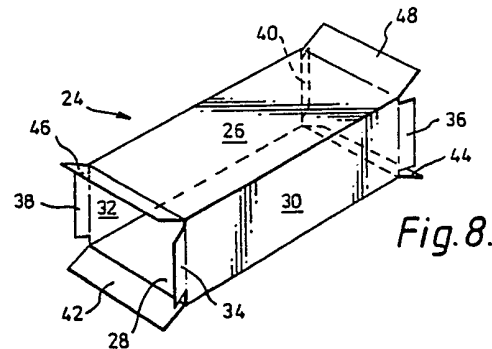
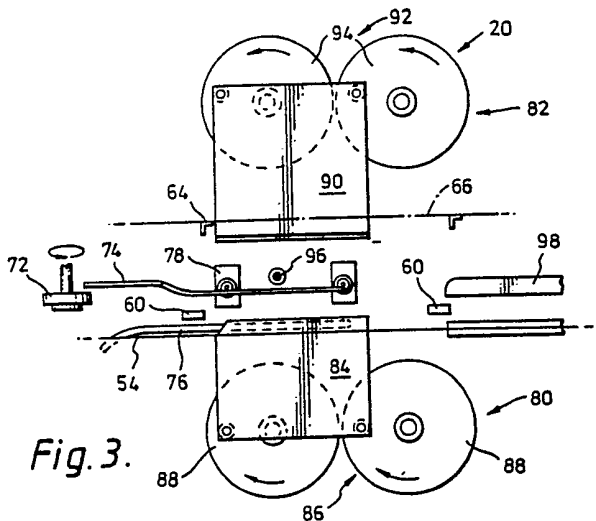

Reprinted front page

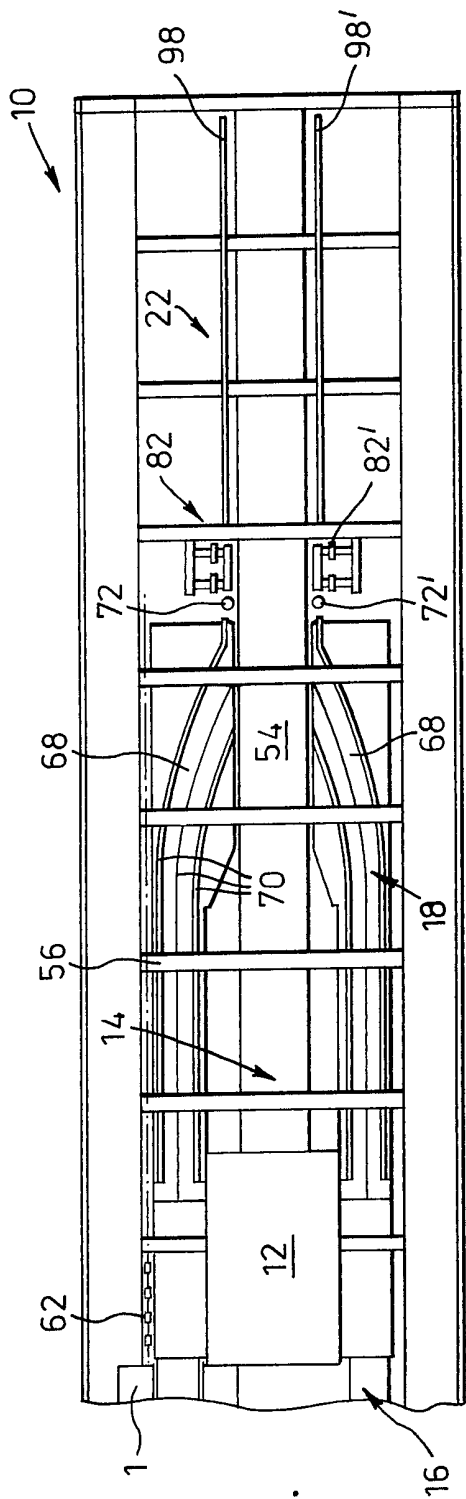

Fig. 1.

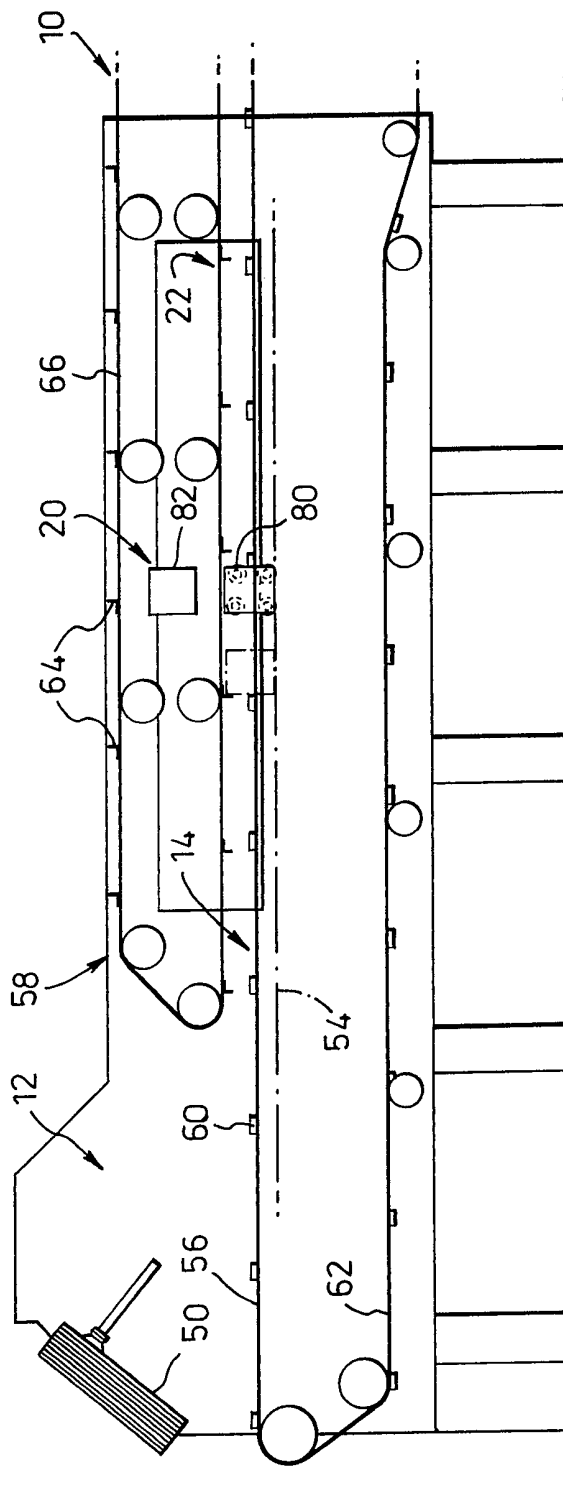

Fig. 2.

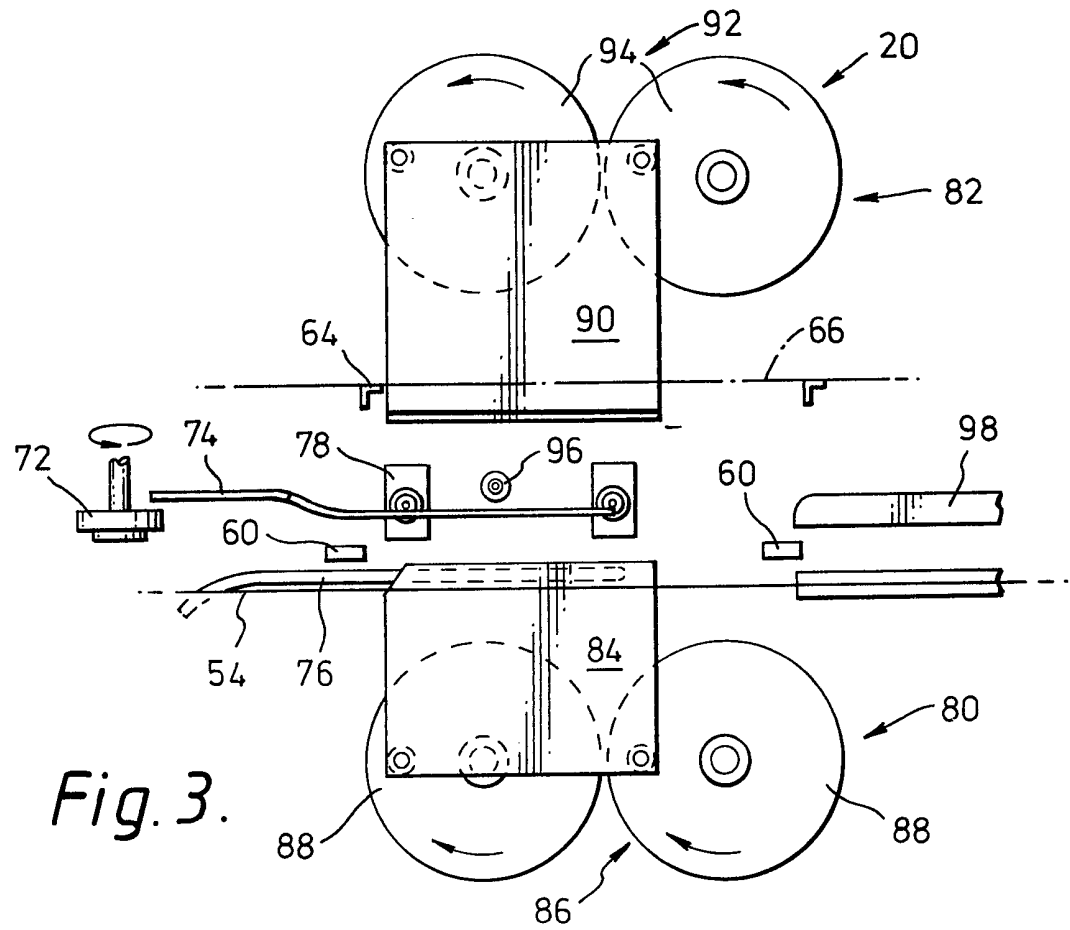

Fig. 3.

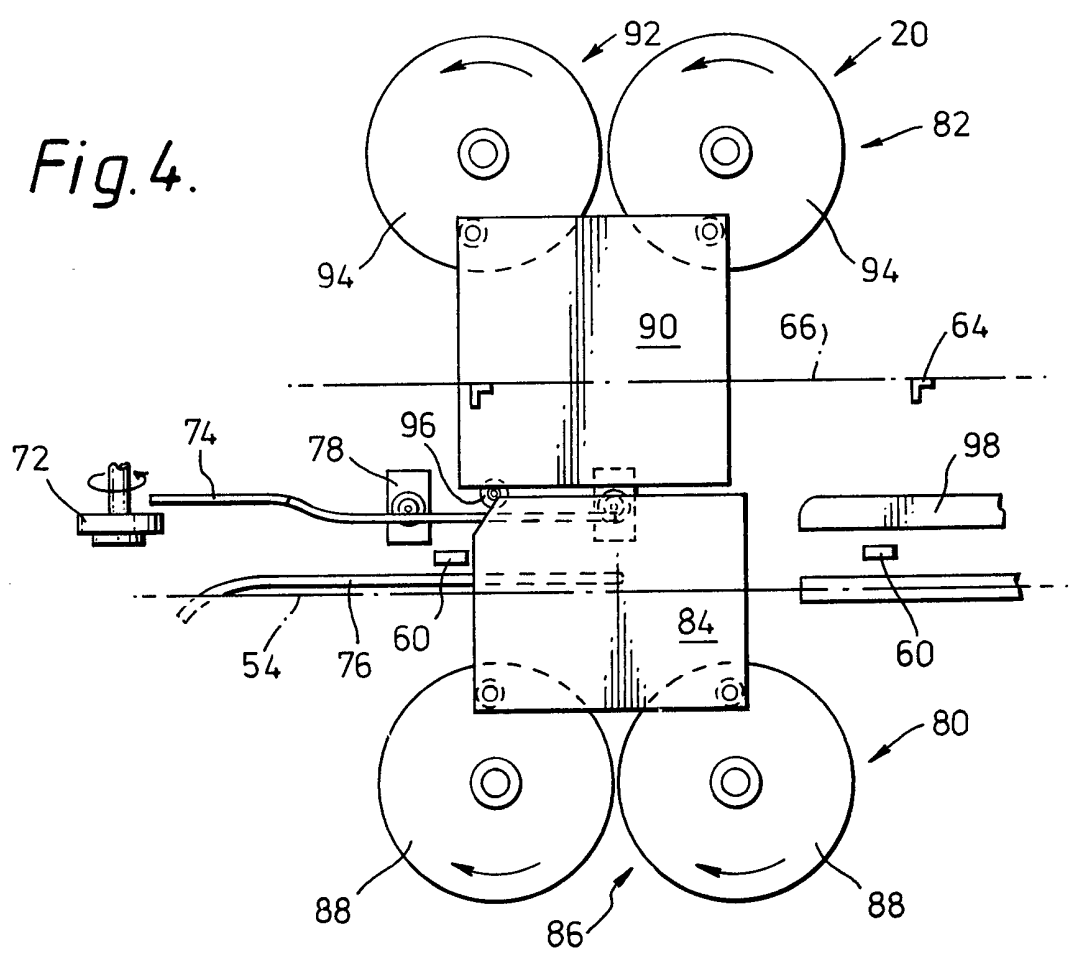

Fig. 4.

Fig. 5.

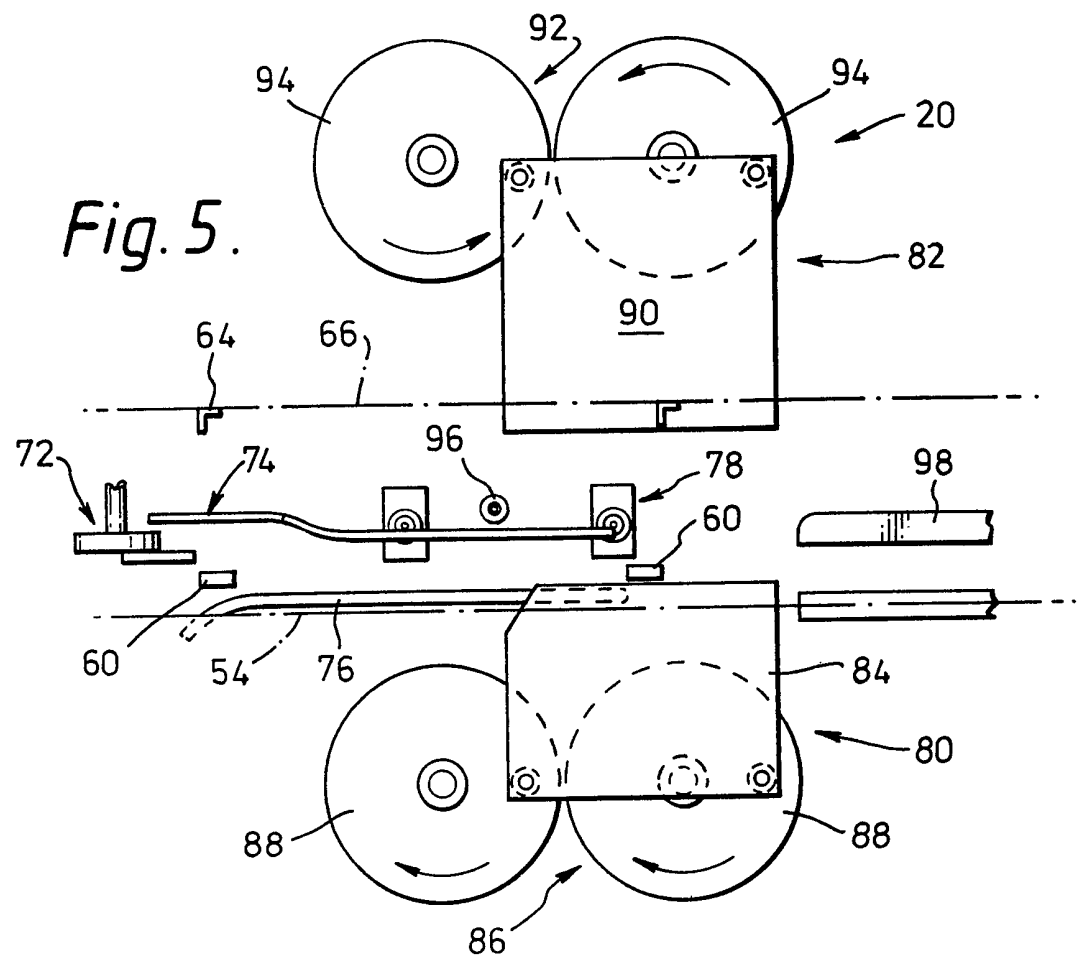

Fig. 6.

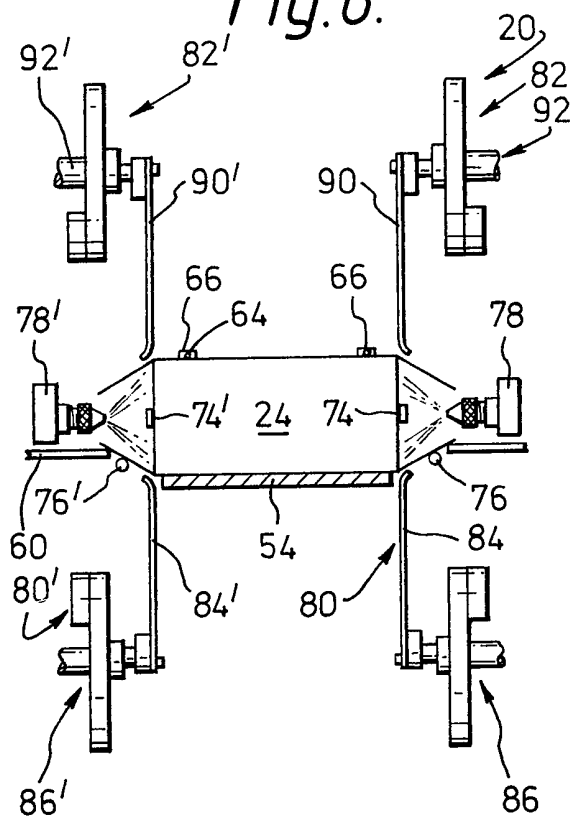
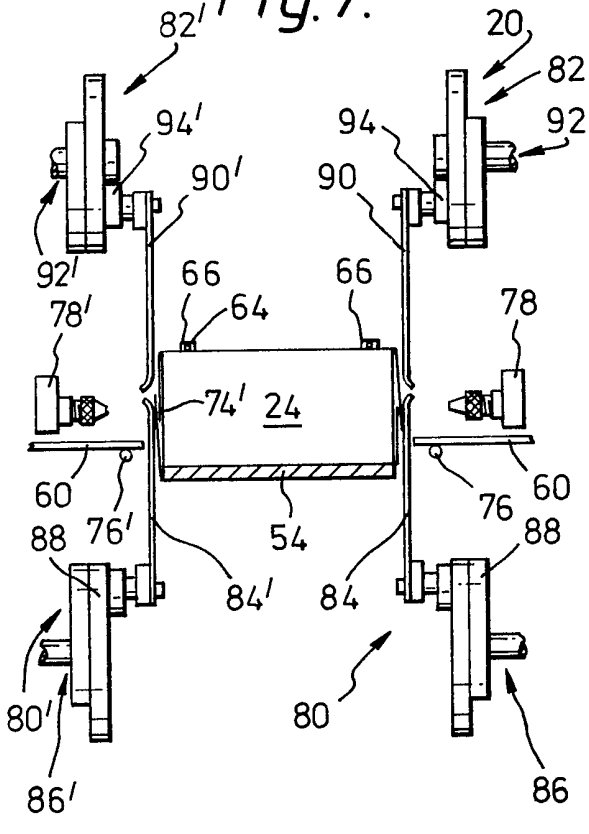

Fig. 7.



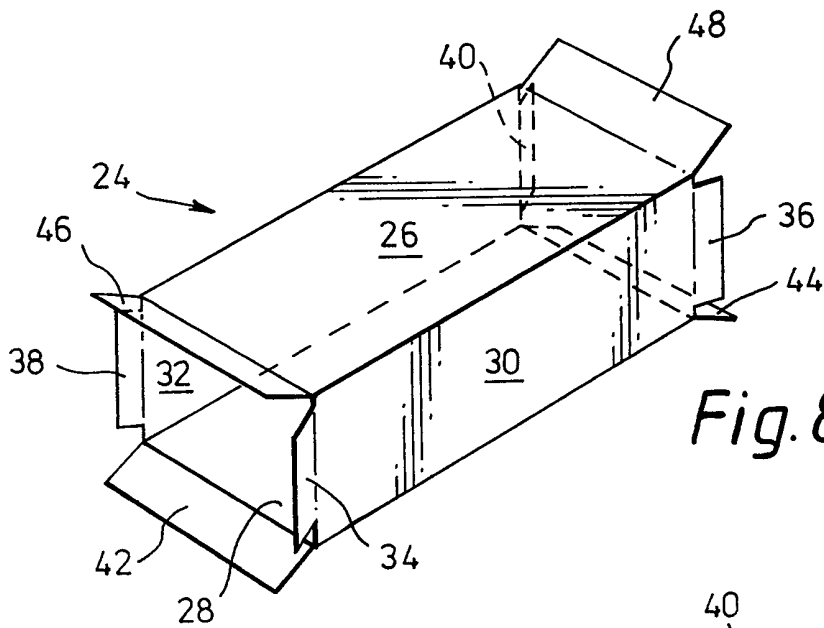

Fig. 8.

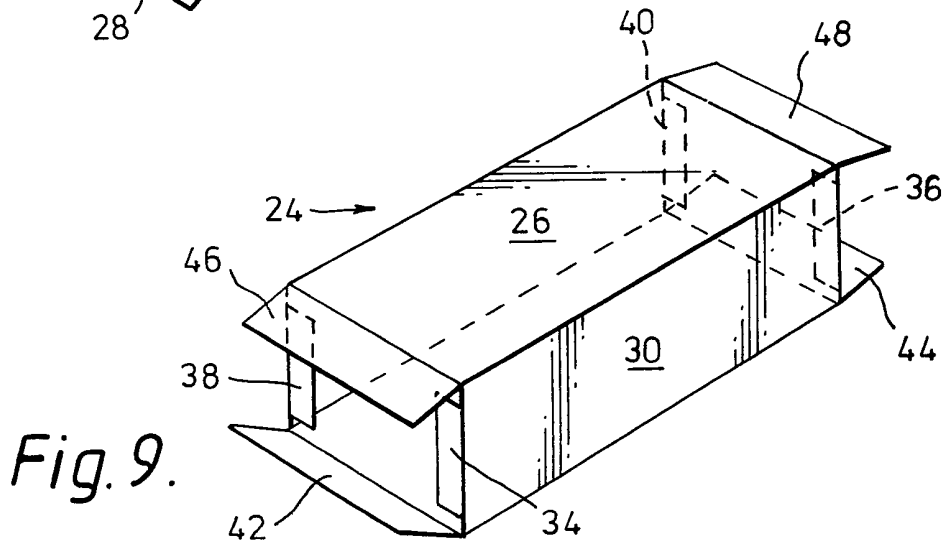

Fig. 9.

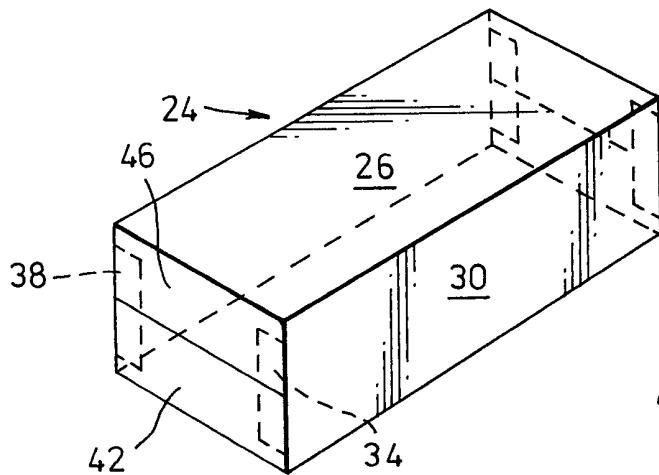

Fig. 10.

SPECIFICATION

Sleeve carton end panel and flap folding and sealing assembly

5 This invention relates to a sleeve carton erecting, loading and sealing machine for packaging a plurality of articles in such cartons and, more particularly, to end panel folding and sealing apparatus which
10 folds the end panels of the cartons against the carton dust flaps and presses the end panels and dust flaps together to seal the carton and complete the packaging operation.

15 Sleeve carton machines which erect folded sleeve carton blanks, load articles to be packaged into the sleeves thus formed, and seal the dust flaps and end panels of the cartons together to form a package are used extensively in the beer and soft drink industries to package beverage cans in twelve packs and the
20 like. These sleeve carton machines normally employ static folding bars for folding the end panels of the cartons against the carton dust flaps and pressing them together while the glue applied between the end panels and dust flaps sets and the cartons are
25 sealed.

The sleeve carton machines which employ the static folding bars operate up to carton packaging rates approaching 150 cartons per minute. However, with increased demands for beer and soft drink
30 beverages the industry has a continuing need to increase the packaging rates of its machines so that each machine can package more articles. The static folding bars of the prior art machines present a problem. The static folding bars exert a drag on the
35 end panels as the end panels are folded and pressed against the dust flaps by the static bars. This causes the cartons to be formed out of square and the end panels do not line up properly with the dust flaps and the sides of the cartons. This presents an
40 aesthetic problem. The misalignment of the carton panels and flaps gives the carton a haphazard or poorly formed appearance to the consumer. In addition, corners of the end panels projecting beyond the side walls of the cartons can catch on
45 other packages or objects. This interferes with the handling and stacking of such packages and can result in the tearing of the end panels.

The carton erecting, loading and sealing machine of the present invention is provided with a unique
50 end panel folding and carton sealing assembly. The present invention eliminates the static folding bars and any need for an auxiliary end panel folding assembly for folding the end panels on machine shutdowns.

55 The end panel folding and carton sealing assembly of the present invention includes a pair of upper folding plates and a pair of lower folding plates. The plates are located on either side of and adjacent to the carton conveyor. Each folding plate is mounted
60 through rotatable mountings to a pair of cranks which move the folding plates through a cycle wherein the plates fold the end panels against the dust flaps and press the end panels against the dust flaps while glue applied between the end panels and
65 dust flaps sets. The motion imparted to the folding

plates by the cranks during this folding and sealing cycle also moves the plates in a downstream direction while the plates are in contact with the end panels. This greatly reduces or eliminates the drag
70 exerted on the end panels and has permitted an increase in operating speeds for such machines to 200 packages per minute without misalignment of the end panels.

Another advantage of the present invention is the
75 elimination of any need for an auxiliary end panel folding mechanism. On normal shutdowns the drives of the folding plates are controlled to stop the folding plates at substantially the midpoints of their folding and sealing cycles thereby assuring that any
80 carton in the folding and sealing station is sealed.

Other objectives and advantages of the present invention will be more apparent from the following detailed description taken in conjunction with the accompanying drawings wherein:

85 *Figures 1 and 2* are schematic plan and elevation views of a carton erecting, loading and sealing machine employing the folding and sealing assembly of the present invention;

Figures 3, 4 and 5 are elevation views of the
90 folding and sealing assembly on one side of the carton conveyor showing the assembly at 90° intervals through the folding and sealing cycle;

Figures 6 and 7 are elevation views of the gluing and sealing station taken from the downstream side
95 of the station with a sleeve carton in the station; and

Figure 8, 9 and 10 are perspective views of a typical carton processed over the machine taken before entering the gluing and sealing station, as glue is being applied to the dust flaps, and after
100 completion of the sealing operation, respectively.

The schematic plan and elevation views of *Figures 1 and 2* illustrate the different stations of a sleeve carton erecting, loading and sealing machine 10. The machine 10 includes a sleeve carton hopper feed
105 station 12, a carton conveyor system 14, an article infeed station 16, an article loading station 18, a gluing and sealing station 20, and a discharge station 22.

As shown in *Figures 8-10* the sleeve cartons 24
110 each comprise a top panel 26, a bottom panel 28 and side panels 30 and 32 which are hingedly joined along fold lines to form a sleeve. In addition each carton has dust flaps 34, 36, 38 and 40 hingedly joined to the ends of the side panels and end panels
115 42, 44, 46 and 48 hingedly joined to the ends of the top and bottom panels. The dust flaps and end panels provide a means to close the ends of the cartons after the cartons have been loaded with the articles to be packaged.

All stations of the machine 10 are conventional state of the art stations except for the gluing and sealing station. The TARGETEER® and TARGETEER®-HIGH SPEED packaging machines of Manville Forest Products Corporation are typical of the machines
125 which could employ the unique gluing and sealing station of the present invention and the operation of such a machine will now be described.

The sleeve cartons 24 are supplied to the machine 10 from the hopper feed station 12. The hopper feed
130 station includes a hopper 50 where the sleeve

cartons 24 are held in flat folded form. The flat folded sleeve cartons 24 are pulled from the hopper by a dispensing and opening mechanism which delivers the opened sleeve cartons to the carton conveyor system 14. When the sleeve cartons 24 are opened, the dust flaps 34, 36, 38 and 40 project parallel to the side panels 30 and 32 and do not interfere with the loading of the sleeve carton. The lower end panels 42 and 44 are folded down and the upper end panels 46 and 48 are folded up and held back from the open ends of the sleeve carton by lower and upper folding bars to permit the loading of articles into the sleeve cartons at the article loading station 18.

The sleeve carton conveyor system 14 includes a stationary center metal bed plate 54, a lower flight bar conveyor 56 and an upper flight lug conveyor 58. The center metal bed plate 54 extends from the hopper feed station 12 downstream through the discharge station 22. The lower flight bar conveyor 56 comprises series of spaced flight bars 60 which contact the trailing side panels of the sleeve cartons. The flight bars 60 are connected by a pair of drive chains 62, are spaced above the bed plate 54, and move downstream over the upper surface of the bed plate 54 conveying the sleeve cartons 24 through the machine 10 from the feed hopper station 12 to the discharge station 22. The upper flight lug conveyor 58 includes a series of pairs of lugs 64 with each pair of lugs located directly above a flight bar 60 of the flight bar conveyor. The pairs of lugs are joined by drive chains 66. The lugs 64 engage the trailing side panels of the sleeve cartons adjacent their upper edges and together with the flight bars 60 convey the sleeve cartons through the machine.

The article infeed conveyor 16 delivers the articles to be packaged into the article loading station on either side of the hopper feed station. The article loading station 18 includes a pair of slide plates 68 located on opposite sides of the hopper feed station 12 and carton conveyor system 14. The slide plates are each provided with sets of guide ribs 70 which project above the surfaces of the slide plates and extend from the article infeed conveyor to the location where the articles are loaded into the open ends of the sleeve cartons. As shown in Figures 1 and 2 the flight bars 60 extend across the slide plates 68. Accordingly, as the articles to be loaded into the carton sleeve are delivered to the article loading station by the infeed conveyor 16, the articles are engaged by the flight bars 60 and moved downstream. The curvature of the guide ribs 70 guides the articles toward the carton conveyor system 14 as the flight bars 60 move the articles downstream. At the location where the guide ribs 70 terminate adjacent the sides of the bed plate 54, the downstream movement of the flight bars 60 together with the guide ribs 70 causes the articles to be loaded into the open ends of the sleeve cartons 24 being conveyed by the flight bars.

After the articles are loaded into each sleeve carton 24 and as the loaded sleeve carton leaves the loading station 18 the end panels are released by the upper and lower fold back bars. The dust flaps and end panels are then closed and sealed together in

the gluing and sealing station 20 and the finished package is then delivered into the discharge station 22 where the cartons 24 are removed to be stored or shipped. The apparatus of the gluing and sealing station and its function will now be described in detail.

As shown in Figures 3 through 7, the gluing and sealing station 20 includes a pair of dust flap tucking fingers 72, 72' a pair of static dust flap folding rods 74, 74', a pair of lower end panel folding rods 76, 76' two pair of glue guns 78, 78', a pair of lower end panel folding assemblies 80, 80', and a pair of upper end panel folding assemblies 82, 82'.

The dust flap tucking fingers 72, 72' and the static dust flap folding rods 74, 74' cooperate to fold the leading and trailing dust flaps of each carton so that the dust flaps on each end of the carton extend inward toward each other as illustrated in Figure 9. The static dust flap folding rods 74, 74' are located directly opposite each other on either side of the bed plate 54. The rods 74, 74' are mounted adjacent the lateral edges of the bed plate but are spaced above those edges a distance approximately equal to half the height of the dust flaps. Adjacent the leading ends of the rods 74, 74' are mounted the pair of tucking fingers 72, 72'. The tucking fingers rotate about a vertical axis and in a downstream direction as the fingers pass adjacent the edges of the bed plate 54. The height of the tucking fingers above the bed plate is also approximately half the height of the dust flaps.

The pair of static lower end panel folding rods 76, 76' are mounted directly opposite each other on opposite sides of and spaced laterally from the edges of the bed plate 54. The leading ends of the folding rods 76, 76' are turned down below the horizontal plane of the bed plate so that the rods 76, 76' can pass under the lower end panels 42 and 44 of the sleeve carton 24. The main portions of the folding rods 76, 76' extend horizontally above the horizontal plane of the bed plate a sufficient distance to raise the lower end panels to an angle of about 20° above the horizontal.

The two pair of glue guns 78, 78' are mounted directly opposite each other on opposite sides of and spaced laterally from the edges of the bed plate 54. The height of the glue guns above the horizontal plane of the bed plate 54 is approximately half the height of the sleeve carton 24 and the nozzles of each pair of the guns are directed substantially horizontally inward toward the other pair of glue guns. The spacing between the glue guns of each pair equals the distance between the midpoints of the dust flaps. The glue guns are mounted in the gluing and sealing station at locations which align the glue guns with the midpoints of the dust flaps just prior to contact between the lower end panels 42 and 44 and the lower end panel folding assemblies 80, 80'.

Each of the lower end panel folding assemblies 80, 80' include a folding plate 84, 84' and a pair of crank assemblies 86, 86'. The folding plates are flat, substantially equal in length to the width of the sleeve cartons, and are rotatably mounted at each lower corner to the crank arms 88, 88' of the crank assemblies. The plates 84, 84' are mounted to move

in vertical planes adjacent the lateral edges of the bed plate 54 between the end panel folding rods 76, 76' and the dust flap folding rods 74, 74'. The crank arms of each crank of the lower panel folding assemblies 80, 80' are equal in length and extend parallel to each other. Accordingly, the folding plates 84, 84' of lower end panel folding assemblies 80, 80' move in unison from positions corresponding to that shown in Figure 3 where the plates are at the beginning of their folding and sealing cycle, to a second position as shown in Figure 4 midway through the folding and sealing cycle where the folding plates of the upper and lower assemblies almost meet, to a third position as shown in Figure 5 at the end of the folding and sealing cycle. The folding plates 84, 84' then pass through the lower 180° of their cycle to return to the position shown in Figure 3.

Each of the upper end panel folding assemblies 82, 82' include a folding plate 90, 90' and a pair of crank assemblies 92, 92'. The folding plates are flat, substantially equal in length to the width of the sleeve cartons, and are rotatably mounted at each upper corner to the crank arms 94, 94' of the crank assemblies 92, 92'. The plates 90, 90' are mounted to move in vertical planes directly above the lower folding plates 84, 84'. The crank arms 94, 94' of each crank of the crank assemblies 92, 92' are equal in length to each other and the lengths of the crank arms of the lower crank assemblies. The crank arms of the upper crank assemblies all extend parallel to each other. However, the cycles of crank arms 94, 94' of the upper crank assemblies follow the crank arms 88, 88' of the lower crank assemblies by a number of degrees sufficient to allow the folding of the lower end panels 42 and 44 by the lower folding plates 84, 84' to lead the folding of the upper end panels 46 and 48 by the upper folding plates 90. Typically the lower crank arms lead the upper crank arms by about five to fifteen degrees. As best seen in Figure 4, the crank arm 94 of the upper crank assemblies 92 are about 10° from vertical while the crank arms 88 of the lower crank assemblies are vertical.

The folding plates 90, 90' of the upper folding assemblies move in unison from positions corresponding to that shown in Figure 3 where the folding plates are at the beginning of their folding cycle, to the midpoint of their folding cycle as shown in Figure 4 where the upper and lower folding plates almost meet, to the end of the folding cycle as shown in Figure 5. The folding plates then pass through the upper return portion of their cycle to the position shown in Figure 3.

The folding and sealing portion of the packaging operation is as follows. After each sleeve carton 24 has been loaded with articles, the carton passes from the loading station 18. As the sleeve carton passes from the loading station the dust flaps and end panels are released and the carton appears as illustrated in Figure 8.

The flight bars 60 convey the sleeve carton to the gluing and sealing station 20. As the sleeve carton enters the gluing and sealing station the leading dust flaps 34, 36 are contacted by dust flap folding rods

74, 74' and folded inward to extend upstream toward the trailing dust flaps. The trailing dust flaps 38, 40 are then folded into place by the tucking fingers 72, 72' and held in place by the tucking fingers until the trailing dust flaps also pass downstream behind the folding rods 74, 74'. The rotations of the tucking fingers are synchronized with the movement of the flight bars so that the fingers pass through the folding portions of their cycles as the trailing dust flaps are opposite the tucking fingers.

The lower end panels 42, 44 then ride up on the lower end panel folding rods 76, 76' and the carton appears as illustrated in Figures 6 and 9. The lower end panels are raised about 20° above the horizontal by the lower end panel folding rods and gravity causes some deflection of the upper end panels 46, 48 downward. With the lower end panels folded and held by the lower end panel folding rods 76, 76', the lower end panels retain the lower ends of the dust flaps in place.

The passage of the sleeve carton into the gluing and sealing station is detected by an electronic eye 96 which actuates the glue guns 78 78' to apply glue to the dust flaps at the position shown in Figure 6 just prior to contact between the lower end panels and the lower folding plates 84, 84'.

Once the glue has been applied to the dust flaps, the lower end panels 42 and 44 are engaged by the lower folding plates 84, 84' and folded into place as the lower folding plates move upward and downstream from the position illustrated in Figures 3 and 6 to the positions illustrated in Figures 4 and 7. The upper end panels 46, 48 are contacted by the upper folding plates 90, 90' after the lower folding plates have started folding the lower end panels up against the dust flaps. The upper folding plates fold the upper end panels down against the dust flaps as the folding plates move downward and downstream from the positions shown in Figures 3 and 6 to the positions shown in Figures 4 and 7.

Since the lower ends of the dust flaps are held in place by the dust flap folding rods 74, 74' and the upwardly inclined lower end panels 42, 44 riding on the lower end panel folding rods 76, 76' prior to the folding of the lower end panels by the lower end panel folding plates, the lower ends of the dust flaps do not interfere with the closing of the lower end panels by the folding plates. Since the folding of the lower end panels precedes the folding of the upper end panels by the upper end panel folding plates, the dust flaps are moved and held in by the lower end panels so that the dust flaps do not interfere with the closing of the upper end panels by the upper folding plates. While examples of the cycle lead required to achieve this result have been disclosed above, the cycle lead of the lower folding assemblies with respect to the upper folding assemblies only need to be great enough to assure that the dust flaps do not interfere with the closing of the upper end panels.

As the upper and lower folding plates 84, 84' and 90, 90' move through the folding and sealing portions of their cycles illustrated at 90° intervals in Figures 3, 4 and 5, the end panels are folded against the dust flaps and the end panels and dust flaps are pressed together between the folding plates and the

articles within the carton while the glue sets.

The cycles of the folding and sealing assemblies are synchronized with the travel of the flight bars so that the cycle just described is repeated as each sleeve carton passes through the gluing and sealing station. In addition the controls of the machine are set so that the folding plates 84, 84' and 90, 90' stop in the positions shown in Figures 4 and 7 during a normal shutdown. In this way any carton then in the gluing and sealing station is sealed and no auxiliary folding and sealing assemblies are required.

As the carton is conveyed from the gluing and sealing station 20 it appears as shown in Figure 10. The sleeve carton passes from the gluing and sealing station into the discharge station where the ends of the carton are contacted by compression bars 98, 98'. The compression bars are mounted opposite each other, adjacent and downstream from the gluing and sealing station and adjacent the edges of the bed plate.

Having described the preferred embodiment of our invention in detail, what we detail to claim and protect by Letters Patent is:

25 CLAIMS

1. In a sleeve carton machine for packaging a plurality of articles within a sleeve carton comprising a top panel, a bottom panel, a pair of side panels, a dust flap hingedly joined to each end of each side panel, an upper end panel hingedly joined to each end of said top panel, and a lower end panel hingedly joined to each end of said bottom panel, machine including a sleeve carton conveyor means for conveying said sleeve cartons through said machine, means for folding said dust flaps on each end of said sleeve cartons inward toward each other after said sleeve cartons have been loaded with articles, means for applying adhesive to outer surfaces of said dust flaps after said dust flaps have been folded inward, and folding means the folding said upper and lower end panels against said dust flaps and pressing said end panels against said dust flaps while said adhesive sets to seal said carton, said folding means comprising a pair of lower end panel folding plates mounted directly opposite each other on either side of and adjacent said sleeve carton conveyor, means for moving said lower folding plates in unison in an upward and downstream direction to fold said lower end panels up against said dust flaps, a pair of upper end panel folding plates mounted above said lower folding plates and directly opposite each other on either side of end adjacent said sleeve carton conveyor, and means for moving said upper folding plates unison in a downward and downstream direction to fold said upper end panels down against said dust flaps.

2. The machine of claim 1 wherein the means for moving said lower folding plates in unison in an upward and downstream direction comprises first and second pairs of lower crank drives rotatably attached to said lower folding plates by lower crank arms, said lower crank drives having cycles of rotation which coincide whereby said lower crank arms rotate and said lower folding plates move in

unison the means for moving said upper folding plates in unison in a downward and downstream direction comprises third and fourth pairs of upper crank drives rotatably attached to said upper folding plates by upper crank arms, said upper crank drives having cycles of rotation which coincide whereby said upper crank arms rotate and said upper folding plates move in unison.

3. The machine of claim 2 wherein the cycles of rotation of said first and second pairs of lower crank drives and the cycles of rotation of said third and fourth pairs of upper crank drives differ.

4. The machine of claim 2 wherein the cycles of rotation of said first and second pairs of lower crank drives lead the cycles of rotation of said third and fourth pairs of upper crank drives.

5. The machine of claim 2 wherein a pair of stationary folding rods are mounted adjacent and upstream from said lower folding plates, and rods being directly opposite each other on either side of and adjacent said sleeve carton conveyor, and said rods having upper surfaces inclined upwardly in the downstream direction to initiate the upward folding of the lower end panels prior to contact between the end panels and said lower folding plates.

6. The machine of claim 2 wherein said crank drives stop with said upper and lower folding plates adjacent each other on a normal shutdown to complete the folding and sealing operation for the sleeve carton being sealed.