



US 20090260330A1

(19) **United States**

(12) **Patent Application Publication**  
Hess et al.

(10) **Pub. No.: US 2009/0260330 A1**

(43) **Pub. Date: Oct. 22, 2009**

(54) **BLOCKING SLIDE UNIT OF A FEED AND SORTING DEVICE FOR PACKAGING MACHINES**

**Publication Classification**

(75) Inventors: **Christian Hess**, Mietingen (DE);  
**Kurt Gnann**, Biberach (DE);  
**Martin Zuleger**, Achstetten (DE)

(51) **Int. Cl.**  
*B65B 5/08* (2006.01)  
*B65B 35/30* (2006.01)  
*B65B 63/00* (2006.01)  
(52) **U.S. Cl.** ..... **53/493; 53/235**

Correspondence Address:  
**JANSSON SHUPE & MUNGER LTD.**  
**245 MAIN STREET**  
**RACINE, WI 53403 (US)**

(57) **ABSTRACT**

A feed and sorting device for tablets has a number of vertically extending filling tubes for tablets and a blocking slide unit for temporarily blocking the filling tubes. The blocking slide unit includes a base plate with first through-openings for the filling tubes, an upper retaining plate with second through-openings for the filling tubes, and a lower retaining plate with third through-openings for the filling tubes. The base plate is between the upper and lower retaining plates, and the first, second and third through-openings are at least partially aligned to allow the filling tubes to pass therethrough. Each blocking finger is supported in a receiving portion on the base plate and is secured thereto by the upper and lower retaining plates. Each blocking finger is assigned to one of the filling tubes, and the receiving portions are formed as recesses which, in a vertical direction, pass through the base plate.

(73) Assignee: **UHLMANN PAC-SYSTEME GMBH & CO. KG**, Laupheim (DE)

(21) Appl. No.: **12/421,976**

(22) Filed: **Apr. 10, 2009**

(30) **Foreign Application Priority Data**

Apr. 16, 2008 (EP) ..... 08007416.4

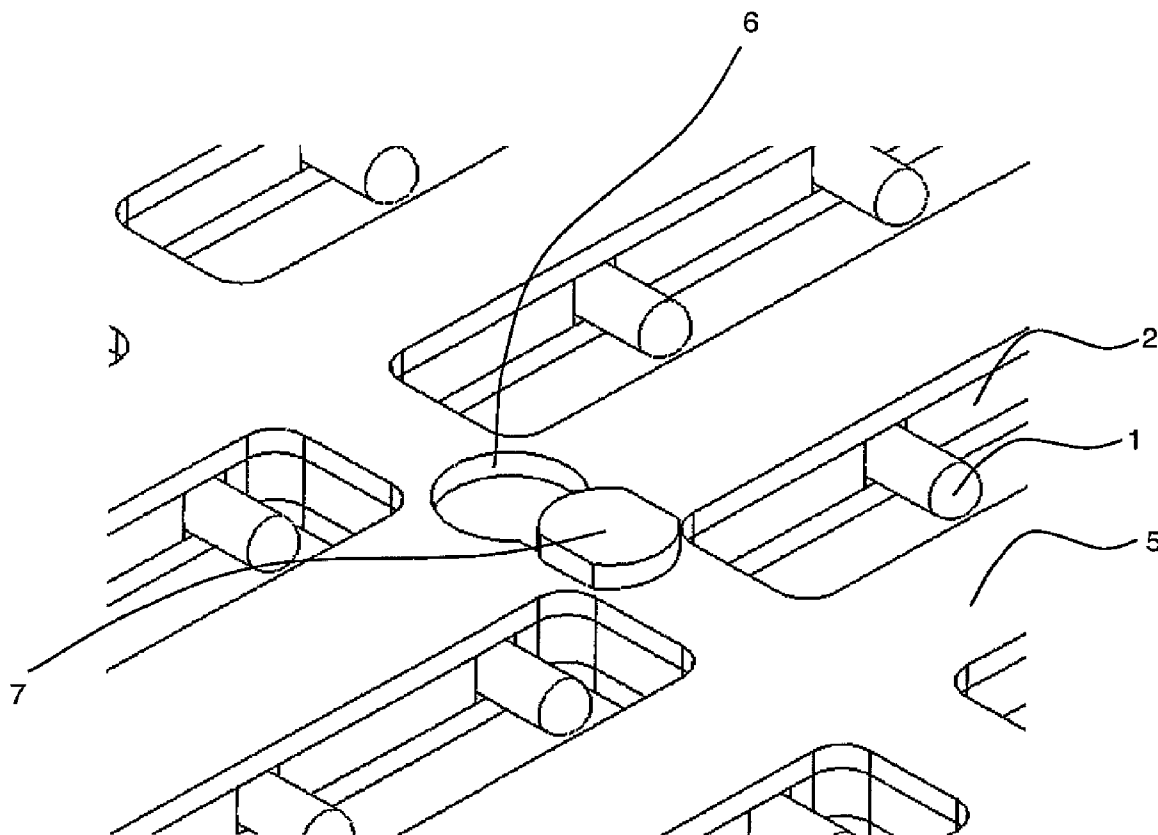

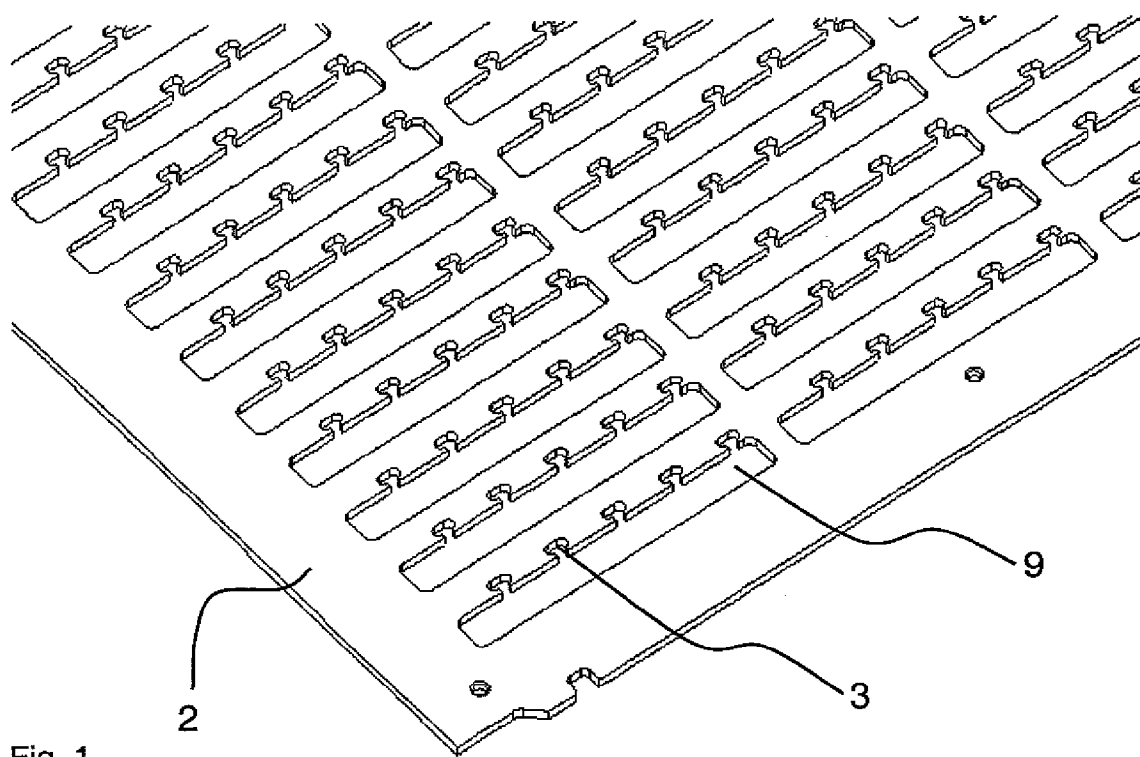

Fig. 1

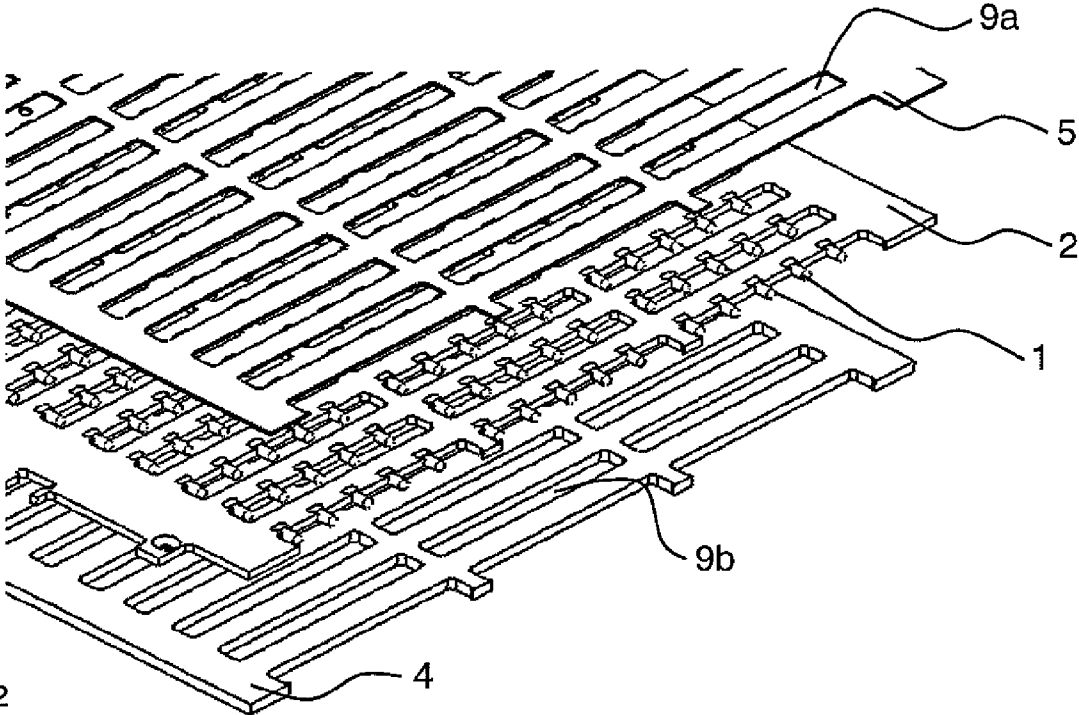

Fig. 2

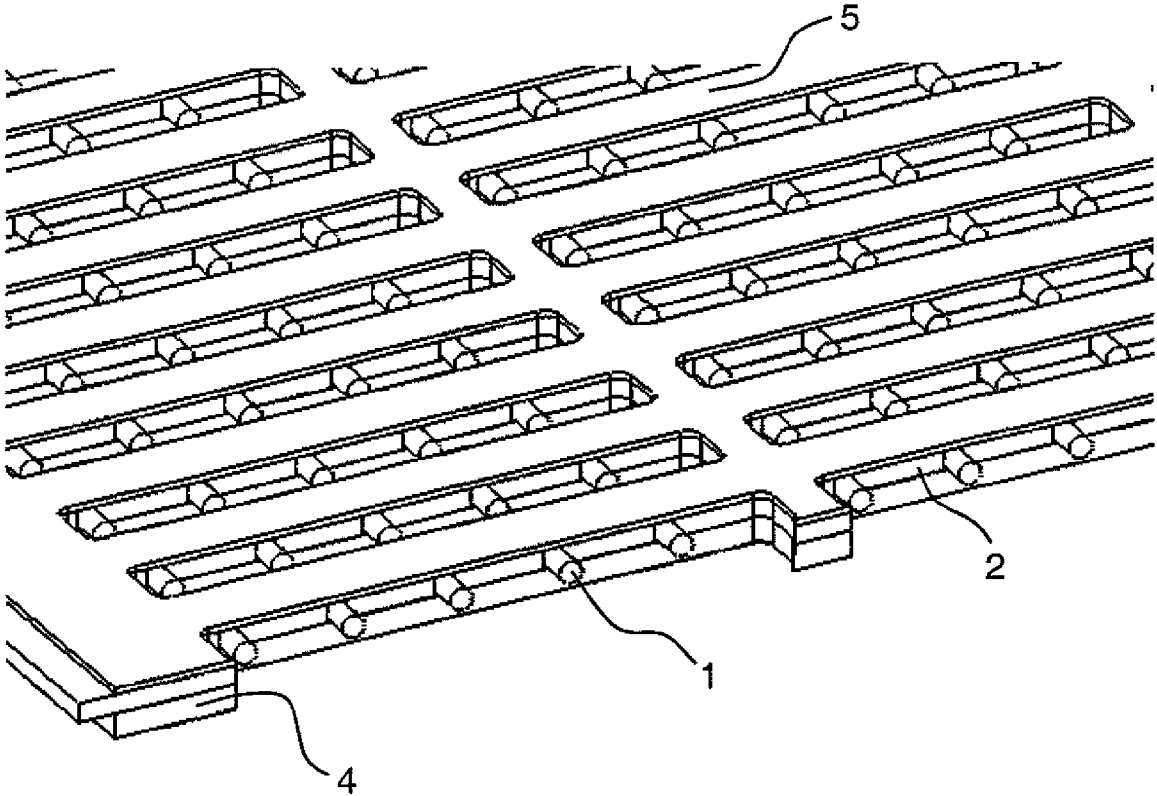

Fig. 3

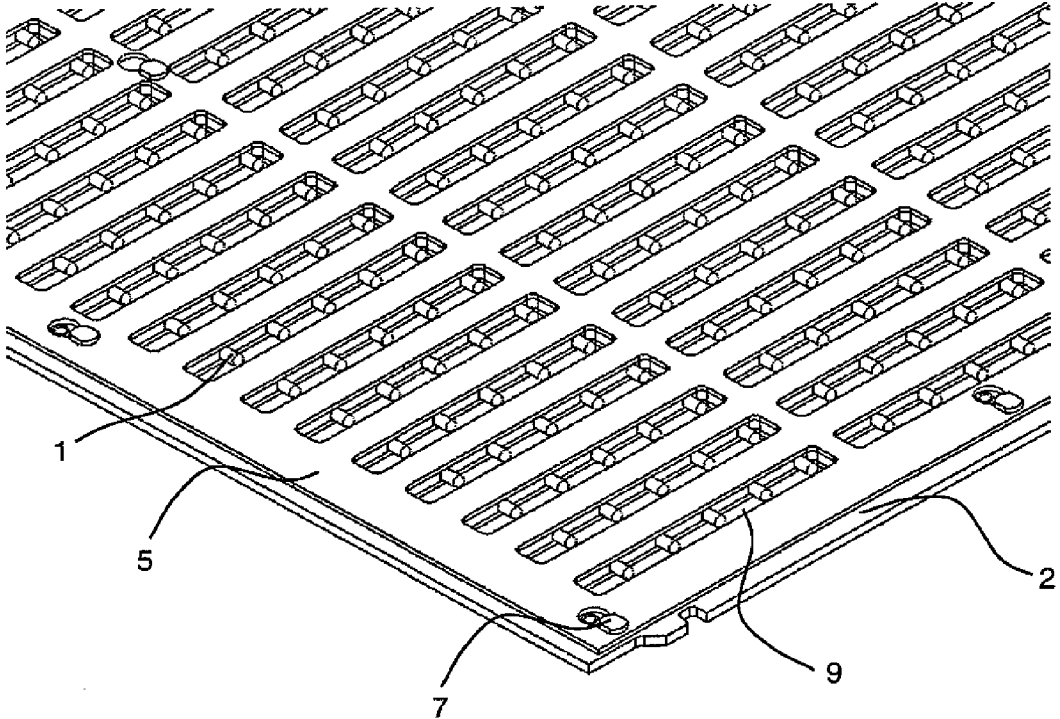

Fig. 4

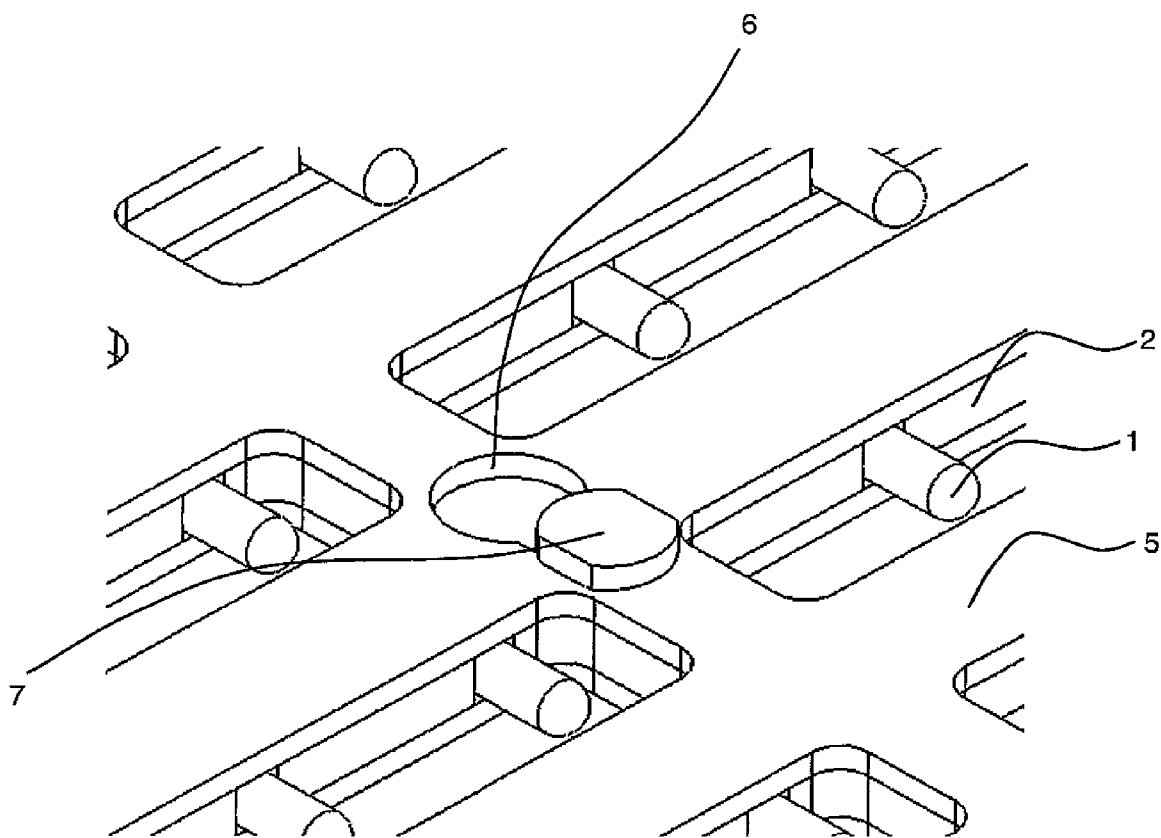

Fig. 5

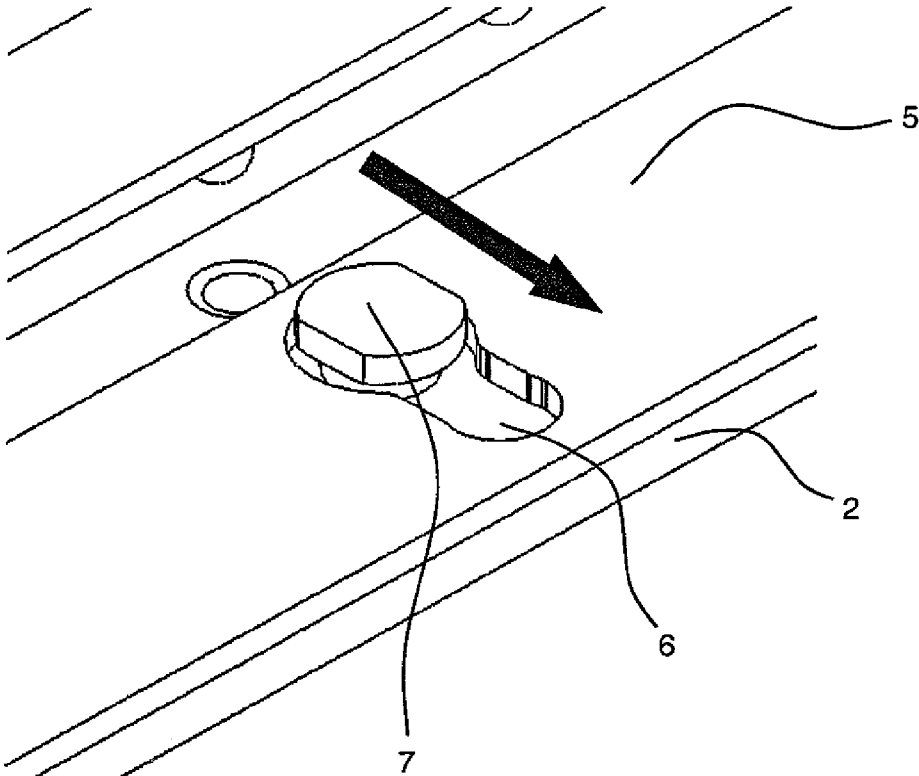

Fig. 6

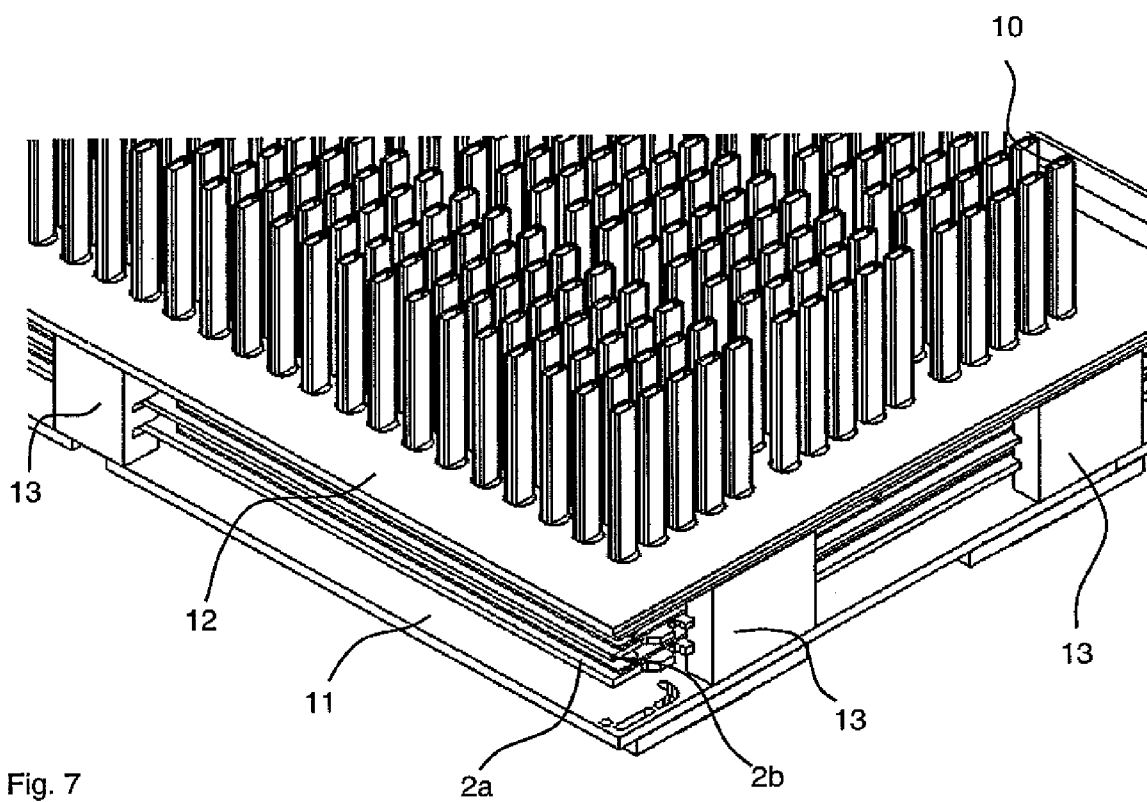

Fig. 7

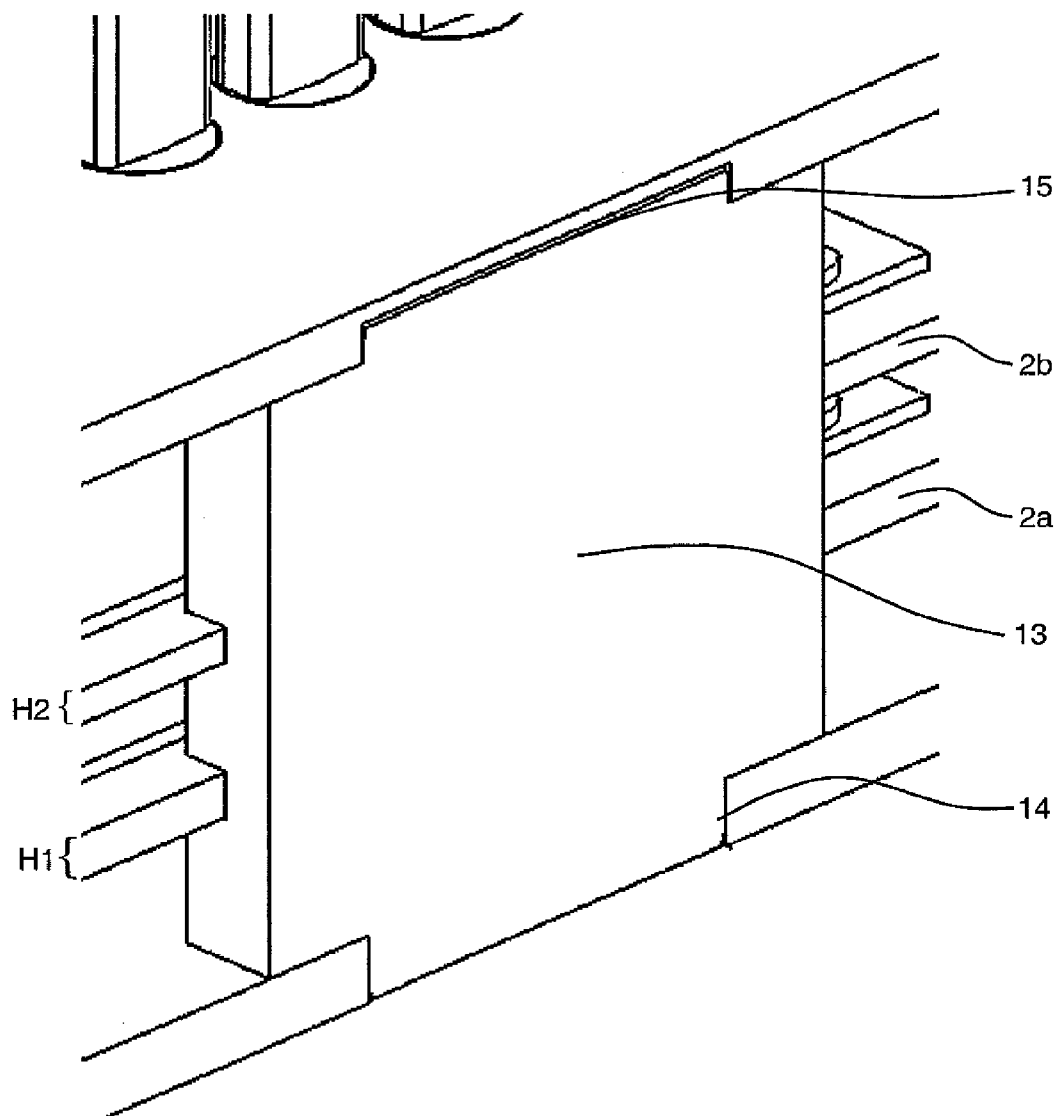

Fig. 8

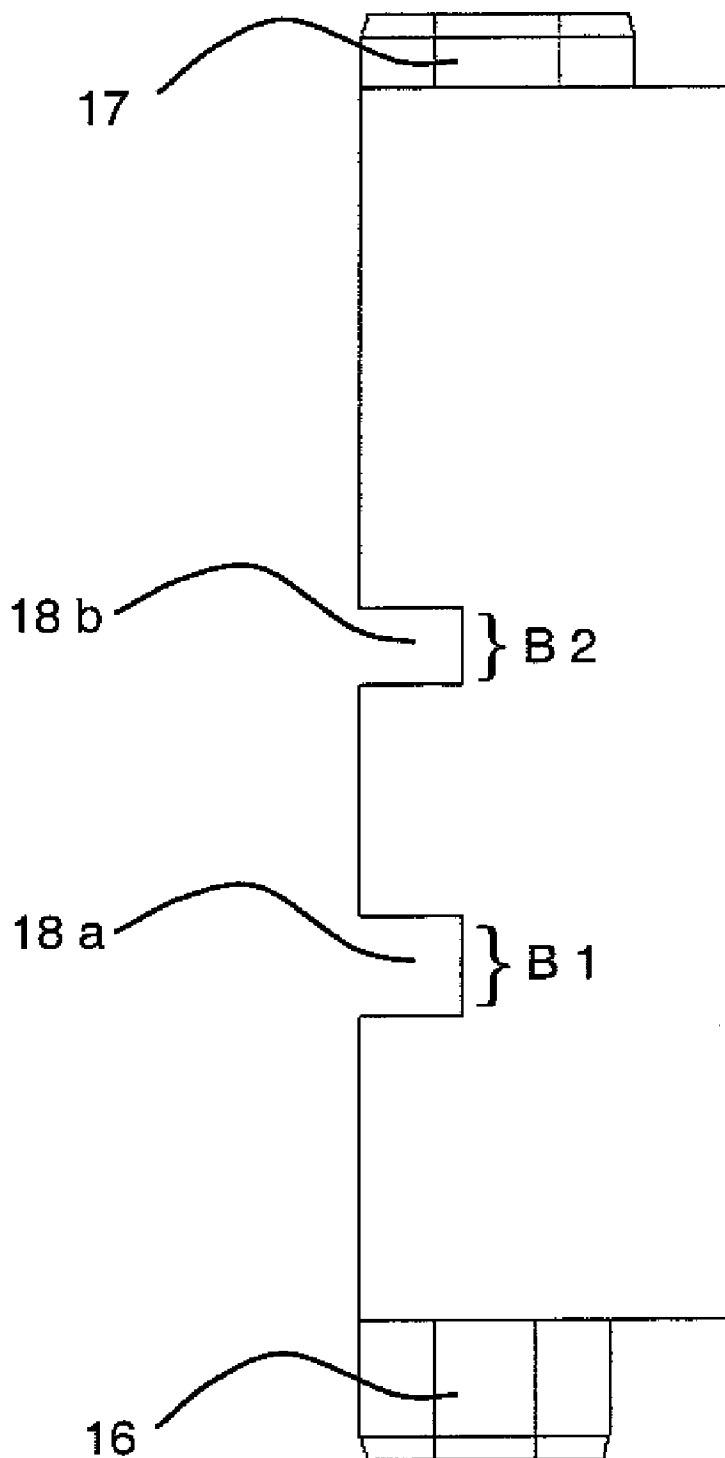

Fig. 9

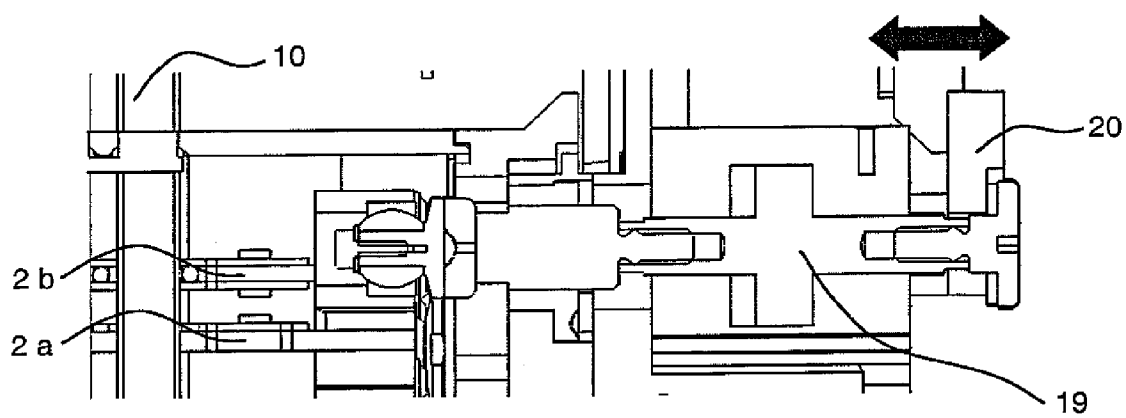

Fig. 10

**BLOCKING SLIDE UNIT OF A FEED AND SORTING DEVICE FOR PACKAGING MACHINES**

**CROSS REFERENCE TO RELATED APPLICATION**

[0001] This application claims priority based on European patent application EP 08 007 416.4, filed Apr. 16, 2008.

**FIELD**

[0002] The field relates generally to blocking slide units of feed and sorting devices for packaging machines and, more particularly, to blocking slide units of feed and sorting devices for tablets, capsules, dragees, or the like, especially on thermoforming machines.

**BACKGROUND**

[0003] Conventional blocking slide units of feed and sorting devices with filling tubes for tablets, capsules, dragees, or the like, especially on thermoforming machines, comprise a number of blocking fingers corresponding to the number of filling tubes, each of these fingers being assigned to one of the filling tubes, and a base plate with a number of through-openings, wherein the base plate comprises sockets for the blocking fingers. In the case of the conventional blocking slide units, the sockets for the blocking fingers are milled into the surface of the base plate.

[0004] During the production of the conventional blocking slide units of feed and sorting devices, this leads to a first disadvantage that, because of the very small geometric forms and the large number of sockets, a long machine operating time is required to produce them. During the handling of the conventional blocking slide units, this leads to the second disadvantage that, because the sockets are introduced into the top surface of the base plate, they make these units very difficult to clean. Because of their geometry, the corners of these sockets cannot be adequately cleaned, and, as a result, residues can remain behind on the base plate.

**SUMMARY**

[0005] It is an object to provide a feed and sorting device for tablets, capsules, dragees, etc., especially on thermoforming machines, having a blocking slide unit which can be manufactured quickly and at low cost and which can be cleaned effectively.

[0006] The feed and sorting device for tablets, capsules, dragees, or the like, comprises a number of vertically extending filling tubes, each tube having a guiding channel for tablets, capsules, dragees, or the like, and a blocking slide unit for temporarily blocking the guiding channels of the filling tubes. The blocking slide unit comprises a base plate with first through-openings for the filling tubes, an upper retaining plate with second through-openings for the filling tubes, a lower retaining plate with third through-openings for the filling tubes, wherein the base plate is arranged between the upper retaining plate and the lower retaining plate, and wherein the first, second and third through-openings are at least partially aligned in order to allow the filling tubes to pass through all of them. The blocking slide unit further comprises a plurality of blocking fingers supported in receiving portions on the base plate, each blocking finger being assigned to one of the filling tubes, wherein the receiving portions are formed as recesses which, in a vertical direction, pass all the way

through the base plate, and wherein the blocking fingers are secured in the receiving portions of the base plate by the upper and lower retaining plates.

[0007] The receiving portions for the blocking fingers can be produced more quickly and at lower cost because there is no need for a milling cutter to produce sockets, which involves considerable time and expense. A laser cutting installation, for example, can be used instead. Depending on the selected materials, furthermore, it may also be possible to use stamping processes, casting processes, injection-molding processes, or even rapid prototyping processes. Because of the arrangement of the lower retaining plate and of the upper retaining plate, the blocking fingers are secured in the receiving portions even though the receiving portions pass all the way through the base plate. Another advantage is that the receiving portions for the blocking fingers can be produced at the same time that the first through-openings are produced in the base plate.

[0008] In the blocking slide unit of feed and sorting devices, a plurality of blocking fingers is preferably assigned to each of the through-openings in the base plate. As a result, manufacturing can be completed more quickly, and a simpler design is also obtained, which is especially advantageous for cleaning operations.

[0009] In the blocking slide unit, furthermore, the receiving portions for the blocking fingers are formed as recesses and can each have a narrowed section at the end where it connects to the first through-opening. This improves the reliability with which the blocking fingers are secured in place during the operation of the blocking slide unit.

[0010] It is advantageous for the blocking fingers to be made of a solid material, especially of steel, aluminum, or plastic, as a result of which the service life and load capacity of the feed and sorting device are improved in particular.

[0011] The blocking fingers, furthermore, can comprise a soft coating, especially a silicone coating. This leads, first, to the fact that sensitive materials are sorted more gently; and second, this has the effect of reducing the accumulation of contaminants. This is an important aspect especially in cases where drugs or food products are involved.

[0012] According to another embodiment of the blocking slide unit, these advantages are achieved in that the blocking fingers are formed out of a soft material, especially silicone.

[0013] The base plate, furthermore, can comprise a number of partial base plates, for the reason that dividing the base plate into a number of partial base plates makes handling easier.

[0014] In other embodiments, the upper retaining plate is mounted on the base plate by at least one fastening means attached to the base plate. This offers the advantage that the time required for disassembly is considerably reduced and also that cleaning is simplified.

[0015] It has been found advantageous for the fastening means to comprise a locking projection, wherein a locking and release opening is provided in the upper retaining plate for the locking projection in such a way that the upper retaining plate can be detached from the base plate or locked in position on the base plate by shifting the base plate relative to the upper retaining plate. As a result, the upper retaining plate can be attached and released quickly and reliably.

[0016] Preferably a clamping device such as a plastic clip is used for the purpose of attachment. In this way, the upper retaining plate is prevented from slipping out of position during operation.

**[0017]** In still other embodiments, instead of one base plate, a corresponding lower base plate with lower through-openings and a corresponding upper base plate with upper through-openings are present, wherein the lower base plate and the upper base plate are arranged with respect to each other in such a way that each lower through-opening and the corresponding upper through-opening are assigned to a corresponding number of filling tubes.

**[0018]** The blocking slide unit preferably comprises at least one guide part with a lower guide for guiding the lower base plate and an upper guide for guiding the upper guide plate, wherein the minimum of one guide part, the lower base plate, and the upper base plate are arranged between a lower cover plate and an upper cover plate. As a result, the base plates can be moved with precision in the blocking slide unit. The guide parts, furthermore, can be inserted into the upper cover plate and the lower cover plate and thus easily held in place, which speeds up the assembly and disassembly processes and simplifies cleaning.

**[0019]** It has been found advantageous for the coding of the lower base plate for the lower guide to be different from the corresponding coding of the upper base plate for the upper guide. As a result of the differences in the codings of the guides and the corresponding differences in the codings of the upper and lower base plates, it is possible to prevent the base plates from being confused with each other.

**[0020]** It is especially preferable for the lower base plate to comprise a first height and for the upper base plate to comprise a second height, wherein the first height differs from the second height, and for the lower guide to be formed as a lower guide groove with a width which accommodates the first height and for the upper guide to be designed as an upper guide groove with a width which accommodates the second height. As a result of the asymmetry of the dimensions, a simple mechanical means is provided which prevents the lower and upper base plates from being confused with each other during assembly.

**[0021]** According to another embodiment, the guide part comprises a first lock on the side facing the upper cover plate and a second lock on the side facing the lower cover plate, such that the first lock and the second lock are different, wherein a first key for the first lock is formed on the side of the upper cover plate facing the guide part for establishment of a connection with the guide part, and a second key for the second lock is formed on the side of the lower cover plate side facing the guide part for establishment of a connection with the guide part. If the guide part has an asymmetric design, confusion during assembly can be prevented automatically.

**[0022]** In an advantageous exemplary embodiment, the first lock is designed as an upper guide projection on the top surface of the guide part; the second lock is designed as a lower guide projection on the bottom surface of the guide part; the first key on the bottom surface of the upper cover plate is designed as an upper guide opening accommodating the upper guide projection; and the second key on the top surface of the lower cover plate is designed as a lower guide opening accommodating the lower guide projection. In addition and/or alternatively, other types of codings, such as, for example, a magnetic coding are also possible, instead of a mechanical coding, to differentiate the upper from the lower surface of the guide part and to fit them appropriately to the different opposing pieces on the lower and the upper cover plates.

**[0023]** In further embodiments, the upper base plate is arranged so that it is movable relative to the lower base plate, wherein an end position of the upper base plate is designed so that it is adjustable. This makes it easier to compensate for tolerances associated with manufacturing, construction, and operation.

**[0024]** The blocking slide unit preferably comprises a pneumatic cylinder to move the upper base plate and a stop for limiting the movement of the upper base plate, wherein the stop is designed so that it can be adjusted by a motor.

**[0025]** According to another embodiment, two of these blocking slide units are connected to each other in such a way that their through-openings are aligned with each other, wherein the blocking fingers of the two blocking slide units are arranged differently from each other, so that the blocking fingers of the blocking slide unit assigned to one set of through-openings are offset from the fingers of the blocking slide unit assigned to the other set. In this way, the tablets, capsules, dragees, etc., can be oriented more effectively and thus the processing speed is increased.

**[0026]** In further embodiments, the blocking slide unit comprises a lower base plate different from the upper base plate, this lower base plate being referred to in the following as the "alternative" base plate. The elements which pertain to the alternative base plate, furthermore, will be designated correspondingly as "alternative" elements.

**[0027]** In the alternative base plate, the alternative blocking fingers required for the blocking slide unit are designed as integral parts of the alternative base plate. Thus, the alternative blocking fingers can be produced together with the alternative base plate more quickly and at lower cost, because, first, there is no need for a milling cutter to produce the receiving portions for the blocking fingers, which is time-consuming and expensive, and second, there is no need for any additional production steps to produce the blocking fingers and to introduce them. An additional advantage of the alternative base plate is that the alternative blocking fingers can be formed when the through-openings are produced. In addition, the alternative blocking fingers are connected to each other, which has the result of simplifying the production of the blocking slide unit. Another advantage is that the conventional receiving portions for the fingers can be eliminated, as a result of which the blocking slide units can be cleaned more thoroughly and more quickly.

**[0028]** In the case of the blocking slide unit of feed and sorting devices, a plurality of alternative blocking fingers is preferably assigned to the through-openings in the alternative base plate. As a result, the speed of production is increased, and the structure is simplified, which is advantageous especially with respect to cleaning operations.

**[0029]** In addition, the alternative base plate and its alternative blocking fingers can be formed out of a solid material, especially steel, aluminum, or plastic, as a result of which the service life and the load capacity of the feed and sorting device are improved in particular.

**[0030]** The alternative base plate with the alternative blocking fingers, furthermore, can comprise a soft coating, especially a silicone coating. The means, first, that sensitive materials are sorted more gently, and second, that the accumulation of contaminants is reduced. This is an especially important aspect in cases where drugs or food products are involved. These advantages can also be achieved by forming the alternative base plate with the alternative blocking fingers out of a soft material, especially silicone.

[0031] The alternative base plate, furthermore, can comprise a number of alternative partial base plates, for the reason that dividing the alternative base plate into a number of alternative partial base plates makes handling easier.

[0032] It has been found advantageous for the alternative base plate to be arranged on an alternative lower retaining plate and for at least one fastening means for fastening the alternative base plate to the alternative lower retaining plate to be attached. This offers the advantage that, with the use of an alternative lower retaining plate, the alternative base plate can be easily set at the desired distance. It has been found useful for the fastening means to comprise a locking projection, wherein, in the alternative base plate, a locking and release opening is assigned to the locking projection in such a way that, by shifting the alternative lower retaining plate in the locking and release opening relative to the alternative base plate, the alternative base plate can be detached from the alternative lower retaining plate or fixed in position on the alternative lower retaining plate. As a result, the alternative base plate can be fastened and released quickly and reliably. The attachment is preferably accomplished by means of a clamping device such as a plastic clip. In this way, the alternative base plate is prevented from slipping out of position during operation.

[0033] The blocking slide unit can also comprise an alternative upper retaining plate, on which the alternative base plate is arranged and on which at least one fastening means for fastening the alternative base plate to the alternative upper retaining plate is attached.

[0034] It has been found favorable for the fastening means to comprise a locking projection, wherein a locking and release opening in the alternative base plate is assigned to the locking projection in such a way that, by shifting the alternative base plate in the locking and release opening relative to the alternative upper retaining plate, the alternative base plate can be detached from the alternative upper retaining plate or fixed in position on the alternative upper retaining plate.

[0035] In embodiments of the blocking slide unit, the alternative base plate could also be used as the upper base plate, when the inventive base plate is used as the lower base plate.

#### BRIEF DESCRIPTION OF THE DRAWINGS

[0036] Exemplary blocking slide unit of a feed and sorting device for packaging machines may be understood by reference to the following description taken in conjunction with the accompanying drawings, in which like reference numerals identify like elements throughout the different views and embodiments.

[0037] FIG. 1 is a perspective view of a base plate according to a first exemplary embodiment of a blocking slide unit of a feed and sorting device;

[0038] FIG. 2 is an exploded view of the blocking slide unit of the first exemplary embodiment;

[0039] FIG. 3 is a perspective view of the blocking slide unit of FIG. 2 in the assembled state;

[0040] FIG. 4 is a perspective view of a base plate according to a second exemplary embodiment of a blocking slide unit of a feed and sorting device, wherein the base plate has an upper and a lower retaining plate and fastening devices;

[0041] FIG. 5 is an enlarged perspective view of the fastening device of FIG. 4 in the locked state;

[0042] FIG. 6 is an enlarged perspective view of the fastening device of FIG. 4 in the released state;

[0043] FIG. 7 is a perspective view of a blocking slide unit according to a third exemplary embodiment with guide parts;

[0044] FIG. 8 is an enlarged perspective view of the guide part of a blocking slide unit according to a fourth exemplary embodiment in the state in which the guide part is installed in the blocking slide unit;

[0045] FIG. 9 is an enlarged cross-sectional view of the guide part of FIG. 8; and

[0046] FIG. 10 is a schematic cross-sectional view of a blocking slide unit according to a fifth exemplary embodiment.

#### DETAILED DESCRIPTION

[0047] For the filling of blister packages, the tablets are usually sorted into vertically extending filling tubes 10 (FIG. 7) of a feed and sorting device by upward and downward movement of the bottom of a sorting plate (not shown) arranged above filling tubes 10. Filling tubes 10 are designed to provide a proper orientation of the tablets. The tablets, which are arranged in a stack in filling tubes 10, must further be singled out so that only individual tablets are fed to each pocket of a blister package. This separation process of single tablets in filling tubes 10 is performed by a blocking slide unit having horizontally extending blocking fingers 1 (FIG. 2) which are moved out of and back into the guiding channel of filling tubes 10. In this way, blocking fingers 1 block the guiding channel in their inserted position, while they allow exactly one tablet per filling tube 10 to fall down in their removed position.

[0048] FIG. 1 shows a first exemplary embodiment of a base plate 2 for a blocking slide unit of a feed and sorting device. Base plate 2 comprises first through-openings 9 and receiving portions 3 for the first blocking fingers 1 (FIG. 2). The receiving portions 3 for blocking fingers 1 pass all the way through base plate 2.

[0049] Receiving portions 3 for blocking fingers can, for example, be cut from base plate 2 by a laser cutting installation at the same time that the first through-openings 9 are cut. It is advantageous for receiving portions 3 for blocking fingers 1 to include a narrowed section at the end where blocking fingers 1 connect to first through-opening 9. It is preferable, as shown in FIG. 1, for a plurality of receiving portions 3 for blocking fingers 1 to be assigned to each first through-opening 9.

[0050] FIG. 2 is an exploded view of the first exemplary embodiment of a blocking slide unit, and FIG. 3 shows the first exemplary embodiment of the blocking slide unit in the assembled state. Base plate 2 is arranged between an upper retaining plate 5 with second through-openings 9a and a lower retaining plate 4 with third through-openings 9b in such a way that blocking fingers 1 are secured in receiving portions 3 of base plate 2, wherein both the second through-openings 9a and also the third through-openings 9b are aligned with the first through-openings 9.

[0051] FIG. 4 shows a base plate 2 with blocking fingers 1 according to a second exemplary embodiment in the locked-together state with a lower (not shown) and upper retaining plate 5, wherein the components which are the same as those of the first exemplary embodiment are designated by the same reference numbers. For a detailed description of them, reference is made to the descriptive sections pertaining to the first exemplary embodiment.

[0052] Upper retaining plate 5 with its corresponding through-openings 9a is preferably attached to base plate 2 in

the locked state in such a way that through-openings **9a** essentially coincide with through-openings **9** in base plate **2**.

[0053] FIG. 5 is an enlarged view of the fastening device in the locked state, and FIG. 6 shows the device in the released state. In the locked state, locking projection **7**, which is arranged on base plate **2** and which includes a neck part and a head part, is located in a narrowed section of the locking and release opening **6** in upper retaining plate **5**, so that the head part of locking projection **7** secures upper retaining plate **5** to the base plate **2**. In the released state, however, the locking projection **7** is located in the widened section of the locking and release opening **6** in upper retaining plate **5**, so that upper retaining plate **5** can be removed from base plate **2** by pulling it over the head part. The arrow shown in FIG. 6 shows the direction in which locking projection **7** has to be moved in order to secure upper retaining plate **5** to base plate **2**. Actually, upper retaining plate **5** of FIG. 6 is pushed parallel to base plate **2** in the direction opposite the arrow to secure it in place or parallel to base plate in the direction of the arrow to release it. In this way, upper retaining plate **5** can be detached from base plate **2** and removed without the use of tools.

[0054] FIG. 7 shows a blocking slide unit according to a third exemplary embodiment, wherein the components which are the same as those of the first and second exemplary embodiments are designated by the same reference numbers. For a detailed description of them, reference is made to the corresponding descriptive sections. The blocking slide unit according to the third exemplary embodiment includes, instead of base plate **2**, a corresponding lower base plate **2a** with lower through-openings (not shown) and a corresponding upper base plate **2b** with upper through-openings (not shown). Lower base plate **2a** and upper base plate **2b** are arranged with respect to each other in the operating state in such a way that in each case a lower through-opening and a corresponding upper through-opening receive an appropriate number of vertically extending filling tubes **10**. Because of their support in guide parts **13**, base plates **2a**, **2b** can be moved with precision in the blocking slide unit.

[0055] FIG. 8 is an enlarged perspective view of guide part **13** in a blocking slide unit according to a fourth exemplary embodiment, wherein the components which are the same as those of the first, second, and third exemplary embodiments are designated by the same reference numbers. For a detailed description of them, reference is made to the corresponding descriptive sections.

[0056] It can be seen in FIG. 8 that guide parts **13** can have different codings both for the connection with upper cover plate **12** and for the connection with lower cover plate **11** and also for the guidance of lower base plate **2a** and of upper base plate **2b**. Lower base plate **2a** comprises a first height **H1**, and upper base plate **2b** comprises a second height **H2**, wherein the first height **H1** differs from the second height **H2**. Upper recess **15** in the upper cover plate and lower recess **14** in the lower cover plate are of different shape. It is possible, for example, for lower recess **14** to extend over the entire height of the lower cover plate, whereas upper recess **15** extends over only a portion of the height of the upper cover plate. In addition to the height, the width and the length of the recesses can also be different. To establish the proper connection, an upper guide projection **17** (FIG. 9), which fits into upper recess **15**, is formed on the top surface of guide part **13**, and a lower guide projection **16** (FIG. 9), which fits into lower recess **14**, is formed on the bottom surface of guide part **13**.

The asymmetry of the lower and upper guide projections ensures that the guide parts will be assembled correctly.

[0057] FIG. 9 shows that the lower guide is designed as lower guide groove **18a** with a width **B1** which accommodates the first height **H1**, and that the upper guide is designed as an upper guide groove **18b** with a width **B2** which accommodates the second height **H2**. The asymmetry of the lower and upper guide grooves together with the asymmetry of the lower and upper base plates provides a mechanical way of preventing the base plates from being confused with each other during assembly.

[0058] FIG. 10 is a cross-sectional view of a blocking slide unit according to a fifth exemplary embodiment, in which upper base plate **2b** is arranged so that it can be adjusted, wherein the components which are the same as those of the first, second, third, and fourth exemplary embodiments are designated by the same reference numbers. For a detailed description of them, reference is made to the corresponding descriptive sections.

[0059] The end position of upper base plate **2b** is adjustable, so that the tablets in filling tubes **10** can be blocked off in optimal fashion. The adjusting distance is preferably continuously variable. This can be accomplished by the use of a motor. Upper base plate **2b** is moved by pneumatic cylinder **19**, which comprises a continuous piston rod. Stop **20** can be used to set the desired position, wherein the stop can be adjusted by the motor, so that no manual interventions are required.

[0060] The technical features of the exemplary embodiments 1-5 can be combined with each other. It is also possible to replace base plate **2** by a number of partial base plates or to replace the upper base plate **2b** by a number of upper partial base plates and the lower base plate **2a** by a number of lower partial base plates.

What is claimed is:

1. A feed and sorting device for tablets, capsules or dragees, comprising:
  - a number of vertically extending filling tubes, each tube having a guiding channel for tablets, capsules or dragees; and
  - a blocking slide unit for temporarily blocking the guiding channels of the filling tubes, the blocking slide unit comprising:
    - a base plate with first through-openings for the filling tubes;
    - an upper retaining plate with second through-openings for the filling tubes;
    - a lower retaining plate with third through-openings for the filling tubes, wherein the base plate is arranged between the upper retaining plate and the lower retaining plate, and wherein the first, second and third through-openings are at least partially aligned in order to allow the filling tubes to pass through first, second and third through-openings; and
    - a plurality of blocking fingers, each finger being assigned to one of the filling tubes, wherein the base plate further comprises a plurality of receiving portions being formed as recesses which, in a vertical direction, pass all the way through the base plate, and the blocking fingers are supported in receiving portions and secured therein by upper and lower retaining plates.

2. The feed and sorting device of claim 1 wherein each of the plurality of receiving portions for the blocking fingers is connected to one of the first through-openings in the base plate.

3. The feed and sorting device of claim 2 wherein each of the plurality of receiving portions for the blocking fingers includes a narrowed section at an end where the receiving portion connects to the first through-opening.

4. The feed and sorting device of claim 1 wherein the blocking fingers are formed of a solid material.

5. The feed and sorting device of claim 4 wherein the solid material is steel, aluminum or plastic.

6. The feed and sorting device of claim 4 wherein the blocking fingers include a soft coating.

7. The feed and sorting device of claim 6 wherein the soft coating is a silicone coating.

8. The feed and sorting device of claim 1 wherein the blocking fingers are formed of a soft material.

9. The feed and sorting device of claim 8 wherein the soft material is silicone.

10. The feed and sorting device of claim 1 wherein the base plate is formed of a plurality of partial base plates.

11. The feed and sorting device of claim 1 wherein at least one fastening means for attaching the upper retaining plate to the base plate is arranged on the base plate.

12. The feed and sorting device of claim 11 wherein the fastening means includes a locking projection, and wherein a locking and release opening is formed in the upper retaining plate assigned to the locking projection in such a way that, by shifting the base plate relative to the upper retaining plate, the upper retaining plate is either detachable from the base plate or lockable on the base plate.

13. The feed and sorting device of claim 1 wherein the blocking slide unit includes an upper and a lower base plate arranged parallel to each other such that the through-openings of the upper and lower base plates are at least partially aligned with each other.

\* \* \* \* \*