

[54] **STAND FOR DECORATING A GRAVE WITH FLORAL ARRANGEMENTS**

[76] Inventors: **Rolf Tebbe; Barend Huiden**, both of
4330 Langenfeldstrasse 47,
Muelheim-Ruhr, Germany

[22] Filed: **Nov. 11, 1971**

[21] Appl. No.: **197,830**

[30] **Foreign Application Priority Data**

Nov. 11, 1970 Germany..... 7041681
June 6, 1971 Germany..... 2128892

[52] **U.S. Cl.**..... **248/27.8**

[51] **Int. Cl.**..... **A47g 7/00**

[58] **Field of Search**..... 248/27.8; 16/191;
40/125 H

[56] **References Cited**

UNITED STATES PATENTS

1,652,937 12/1927 Heinz..... 248/27.8
745,295 11/1903 Raysih 248/27.8

1,135,241 4/1915 Woods..... 40/125 H
1,804,770 6/1931 Hershfield..... 40/125 H
1,955,509 4/1934 Moechel..... 40/125 H
2,075,006 3/1937 Braun 248/27.8
2,919,034 12/1959 Levy 40/125 H
2,989,275 6/1961 Hart..... 248/27.8
3,007,269 11/1961 Jump 40/125 H
3,094,802 6/1963 Perry 40/125 H

FOREIGN PATENTS OR APPLICATIONS

665,516 1/1952 Great Britain..... 40/125 H

Primary Examiner—Edward C. Allen

Attorney, Agent, or Firm—Walter O. Ottesen

[57] **ABSTRACT**

A stand upon which can be placed floral arrangements such as wreaths, sprays and the like for decorating a burial site such as a coffin, grave or tomb has at least two frames mutually connected so as to be positionable over the burial site, each of the frames having a surface for supporting the floral arrangements above the burial site.

9 Claims, 13 Drawing Figures

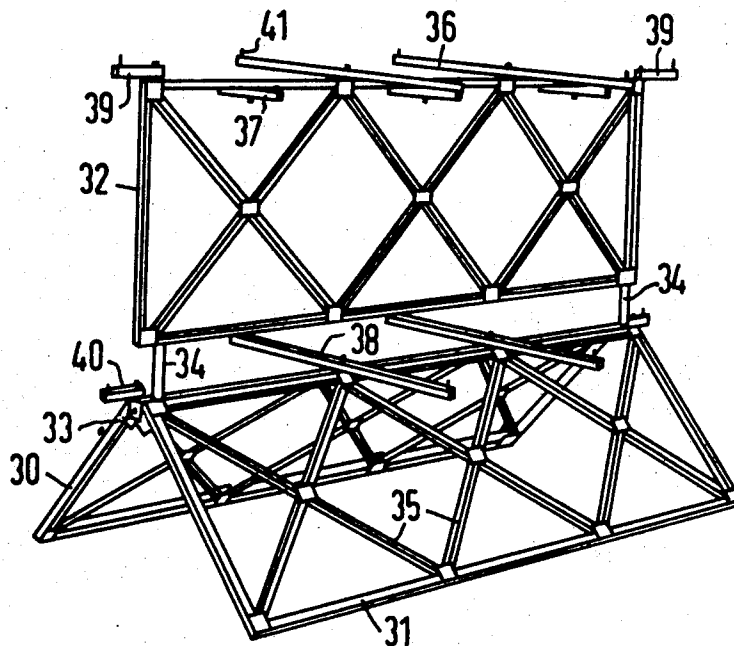

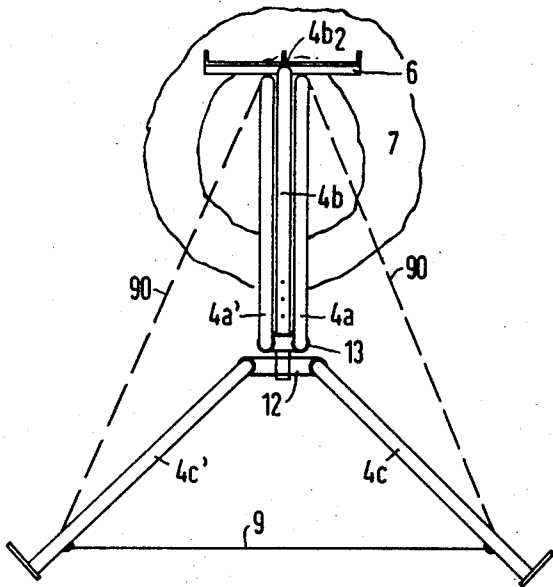

Fig. 3

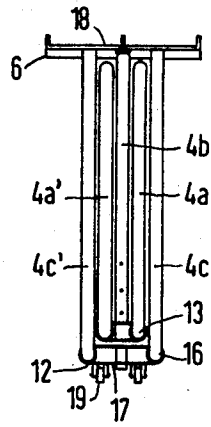

Fig. 4

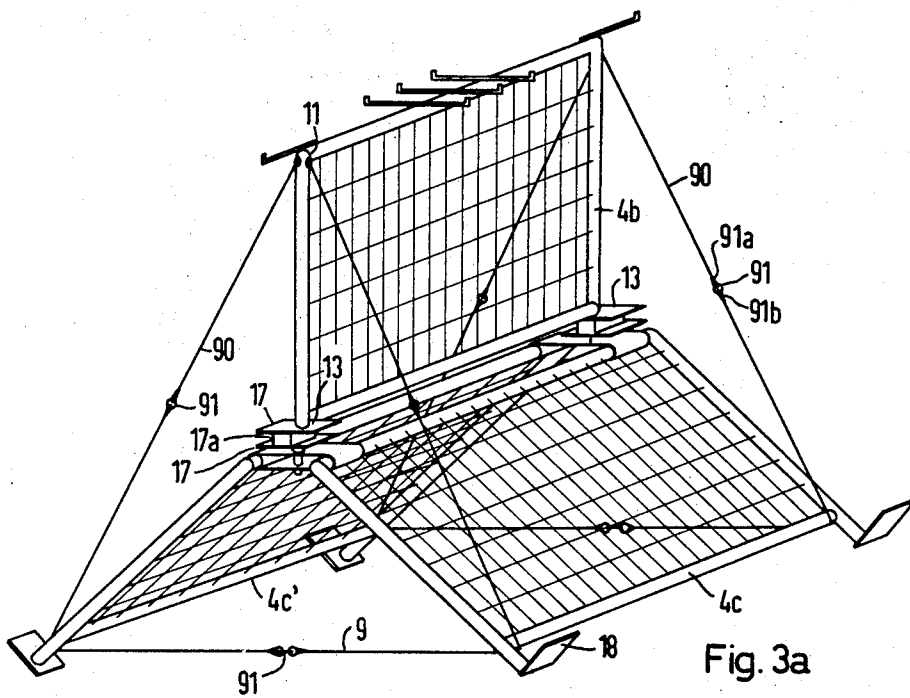

Fig. 3a

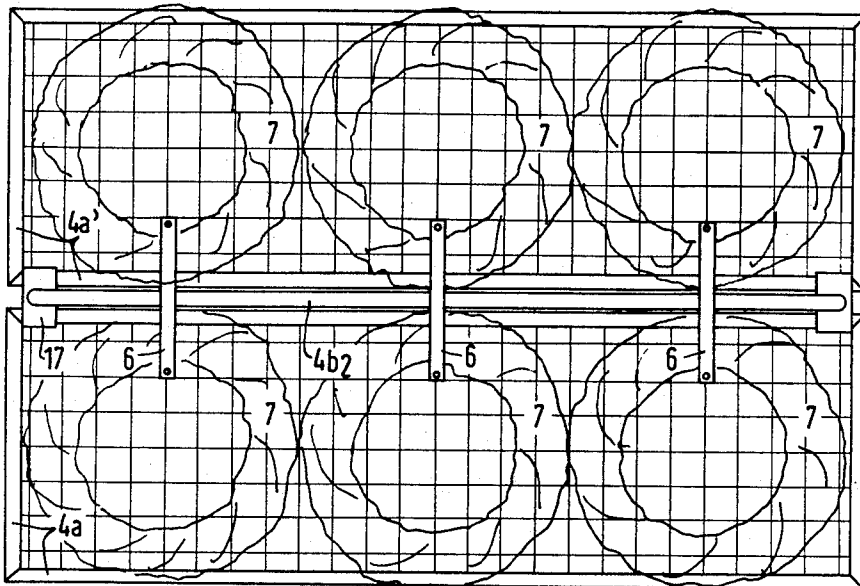

Fig. 5

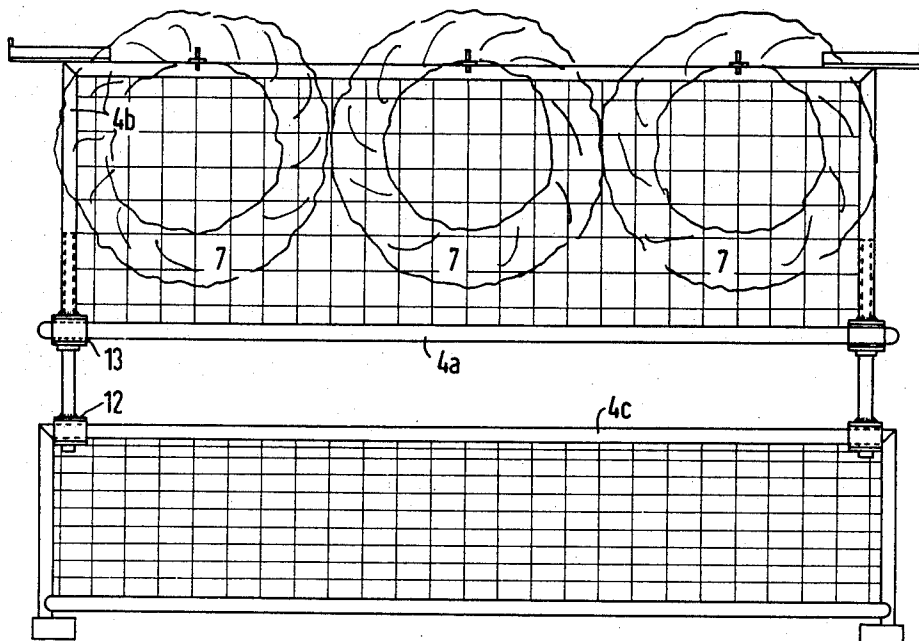

Fig. 6

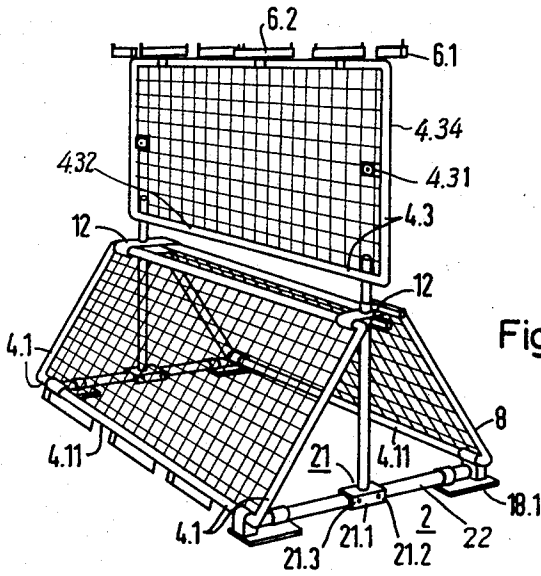

Fig. 7

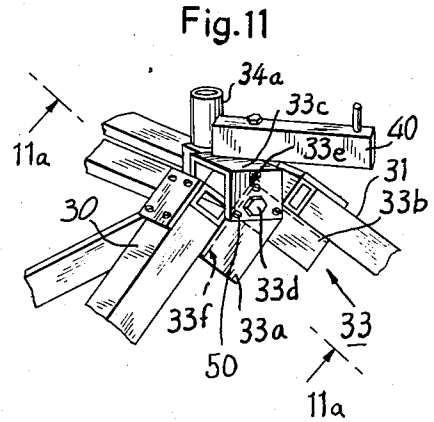

Fig. 11

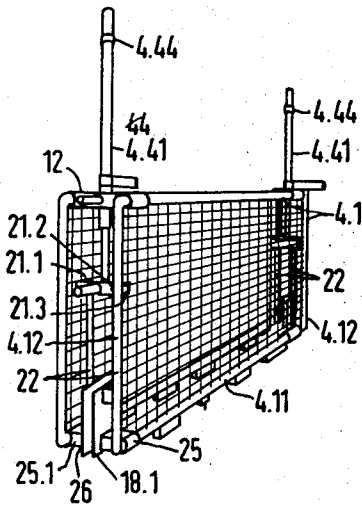

Fig. 9

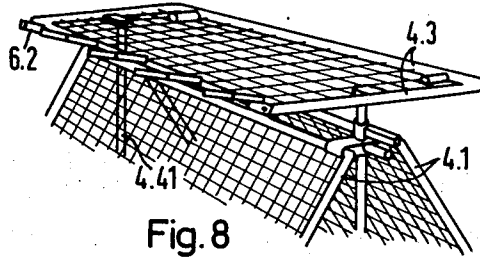

Fig. 8

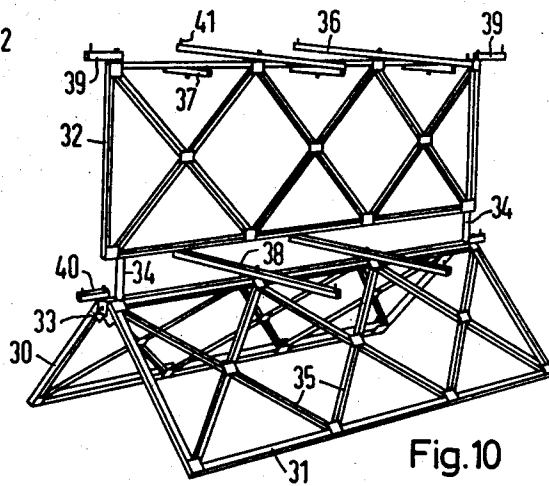
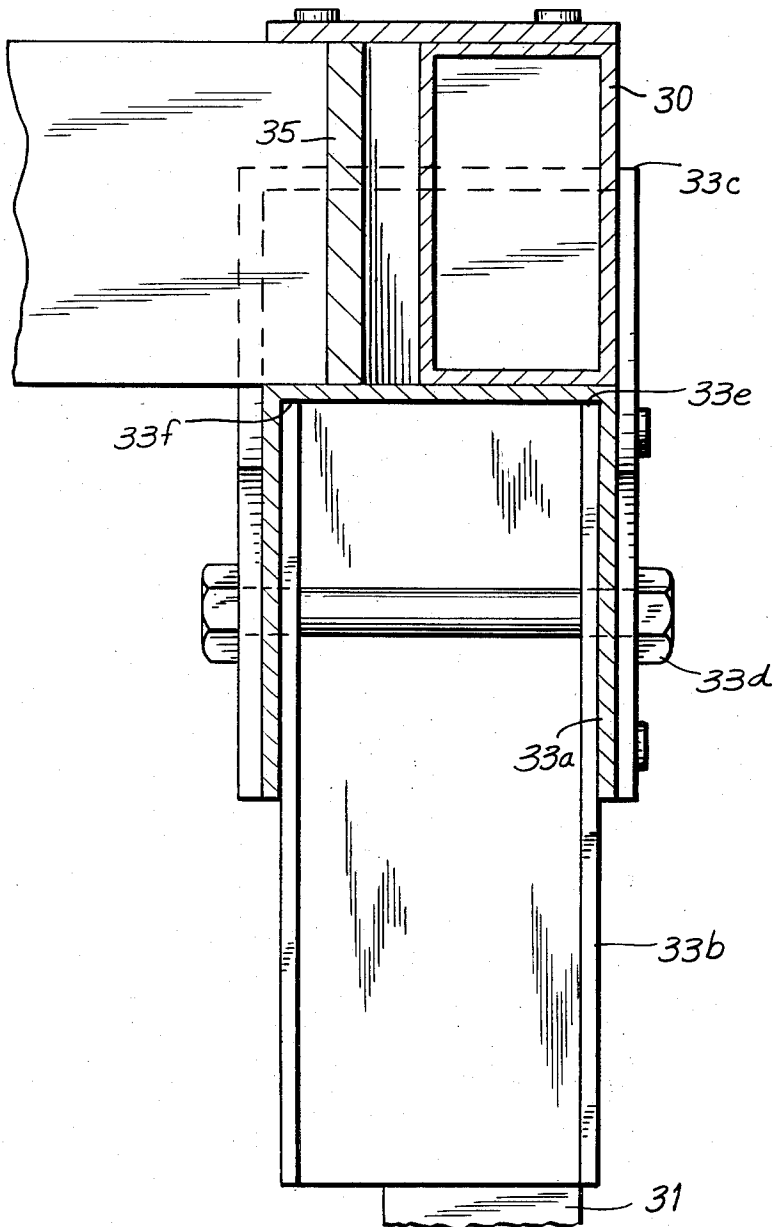

Fig. 10

Fig.11a



STAND FOR DECORATING A GRAVE WITH FLORAL ARRANGEMENTS

Our invention relates to a stand for decorating a grave with floral arrangements. At burials or other occasions such as on memorial days when graves are decorated, a great many wreaths and other floral decorations are placed next to and on top of each other at the grave site. This affords a not too pleasing view for the mourners while at the same time leads to the situation wherein the floral decorations soon become pressed together and are no longer nice to look at.

Accordingly, it is an object of our invention to provide a means for improving the appearance of the floral decorations as well as to preclude damage to the latter. Subsidiary to this object, it is an object of our invention to provide a stand on which the wreaths and the other floral decorations can be nicely arranged at the grave site to provide an optically pleasing appearance while at the same time preventing damage to these floral decorations.

According to a feature of our invention, we provide a stand for floral decorations which is positionable over a burial site such as grave, tomb or coffin and which comprises at least two frames mutually connected so as to be positionable over the burial site. The frames have a surface means for supporting the floral decorations above the burial site. Subsidiary to this feature it is a feature of our invention to provide hanging means on the stand for hanging wreaths and to provide supporting legs on the frames.

The invention affords the advantage that the wreaths and floral decorations can be placed in an appropriate and orderly arrangement at the grave site. This advantage is realized also when there are a great many wreaths, for example more than 20. According to another feature of the invention the stand can be equipped with rollers or wheels at its supporting legs or at the frames, so that a convenient transport of the stand is possible from and to the grave site. It is especially advantageous if the frame portions of the stand or wreath stand can be opened to an expanded position and then collapsed to a compact configuration for facilitating its movement from one location to another. This latter feature affords the advantage that the stand when not in use requires only little space for storage and because of its small dimensions in the collapsed position, the frame assembly is easily transportable and need only first be opened to its operational position at the grave site.

Although the invention is illustrated and described herein as a stand for floral decorations, it is nevertheless not intended to be limited to the details shown, since various modifications may be made therein within the scope and the range of the claims. The invention, however, together with additional objects and advantages will be best understood from the following description and in connection with the accompanying drawing, wherein:

FIG. 1 is a perspective view of a stand for floral decorations according to a first embodiment of the invention and having two supporting levels one on top of the other;

FIG. 2 is an end view of the stand of FIG. 1 wherein the annular outline figures depict wreaths hung at the end face of the stand;

FIG. 3 illustrates an end view of the wreath stand of FIG. 1 wherein the two frames of the upper supporting level are folded together;

FIG. 3a is a perspective view of the stand with the upper frame parts removed;

FIG. 4 is also an end view of stand wherein the wreath stand is shown in its fully collapsed position. Also shown, as a variation of this embodiment, are rollers for rendering the collapsed wreath stand movable;

FIG. 5 is a plan view of the upper supporting level of the stand according to FIG. 1; and,

FIG. 6 is a side view of the stand according to FIG. 1.

FIGS. 7 to 9 illustrate perspective views of another embodiment of the stand for floral decorations according to the invention wherein the fixation of the stand in its operational position is not achieved by means of a line but, instead, is achieved by means of coupled struts. Also, a modification of the supporting rod insertion joint is disclosed.

FIG. 7 illustrates a stand for floral decorations equipped with a vertically mounted additional frame;

FIG. 8 illustrates the stand according to FIG. 7 equipped with a horizontally mounted additional frame in lieu of the vertically mounted additional frame;

FIG. 9 illustrates the lower frames equipped with their supporting rods shown in the collapsed position;

FIG. 10 illustrates still another embodiment of the stand for floral decorations according to the invention wherein the stand is equipped with self-holding hinges for limiting the angular separation of the frames to a predetermined angular separation; and,

FIG. 11 illustrates the self-holding hinge of the stand of FIG. 10.

FIG. 11a is a view, in section, taken along the line 11a — 11a of FIG. 10. The view shows two hinge members of one of the hinges connecting the two lower frames of the stand coacting to prevent angular separation of the frames beyond a predetermined separation angle.

The stand for decorating a grave is designated by reference numeral 1 in FIG. 1 and is configured as a wreath stand which can be positioned over a grave, tomb or coffin. The front view of a coffin is indicated by reference numeral 3. The stand 1 is referred to below also as a wreath stand and comprises frame parts 4 having supporting surface means 5 upon which floral decorations can be placed and having hanging means 6 for the wreaths. The wreaths are depicted in outline in FIGS. 2, 3, 5, and 6 and designated by reference numeral 7. The wreath stand also comprises supporting legs 8. A comparison of FIGS. 1 to 4 shows that the frame parts 4 of the wreath stand 1 can be collapsed from the operational position (FIGS. 1 and 2) into a compact transportable position (FIG. 4) and then opened again to the operational position.

FIG. 3 illustrates an intermediate position of the stand wherein the upper frames 4a, 4a' are collapsed onto the middle base frame 4b; this constitutes the first step of the procedure for folding or collapsing the stand or, if desired, this position of the stand can serve to provide a reduced supporting surface area when a smaller number of wreaths are to be displayed.

As indicated in FIGS. 1 to 4, the wreath stand has frame parts which are generally designated by refer-

ence numeral 4. The individual frame parts 4a, 4a' and 4c, 4c' are pivotally connected so as to be swingable outwardly. The frame parts 4c, 4c' of a lower supporting level I can span the grave site in a roof-like arrangement in the operational position (compare FIGS. 1 to 3). In this position, the frame planes forming the wreath supporting surfaces 5 define a roof-like supporting deck and extend approximately in the longitudinal direction of the grave site 2. The frame planes defined by the frames extend outwardly so as to fall off at a downwardly inclined angle. The illustrated inclination is especially suitable for obtaining a good view of the wreaths and, if required, flowers which may be arranged adjacent the wreaths. The inclined extending frame parts serve here as the supporting legs 8 and a fixation means 9 in the form of a line is used for fixing the supporting legs 8 or the frame parts 4c, 4c' in their operational position, see FIGS. 1 to 3.

The line 9 for example can grasp the lower frame part portion 4c1 of frame 4c in form of a loop and with its other end, the line can be hooked to the lower part 4c2 of frame 4c' on hook 10 by means of an eyelet 11. The same applies to the upper lines 9a, which have respective loops which grasp the outer frame portions 4a1, 4a2 and which have at their other respective ends eyelets 11a for hooking onto hooks 10a.

As shown in FIG. 2, the wreath stand is symmetrical with respect to a vertical symmetry plane III—III and equipped with a pair of lower frames 4c, 4c' which span the grave site 2 in mirror symmetry. In addition, the upper frame pair 4a, 4a' is also arranged in mirror symmetry. This provides a pleasing appearance with a sufficiently large supporting surface 5. The wreath stand as already mentioned, has a rectangular base frame 4b arranged in the vertical symmetry plane III—III. Base frame 4b consists of vertical support rods 4b1 and longitudinal rods 4b2, the supporting rods 4b1 and longitudinal rods 4b2 forming a closed frame. At the lower ends of the supporting rods 4b1 are attached respective articulating joint members 12 for pivotally bearing the frame pairs 4c, 4c', that is, the lower frame pair can be collapsed from the operational position shown in FIGS. 1 to 3 to the collapsed position of FIG. 4 by a folding action taken in direction of the arrows p shown in FIG. 2. And, if an upper pair of frames 4a, 4a' are provided, then these must first be collapsed as indicated in FIG. 3.

For bearing the above mentioned upper frame pairs 4a, 4a', the supporting rods 4b1 of the base frame 4b are provided with additional articulating joint members 13 in a second plane lying above the joint plane of the lower frame pairs 4c, 4c'. In this way, the second or upper supporting level or deck II is formed with the associated fixation means in the form of lines 9a.

With reference to its supporting rods 4b1, the base frame 4b is configured in a special manner; namely, the supporting rod 4b1 consists of mutually telescoped supporting rod parts 4b10, 4b11 so that rod 4b1 can be adjusted in length. The supporting rod parts 4b10 are the outer sleeve members in which the supporting rod part 4b11 of smaller diameter are slideably borne in the longitudinal direction. By means, for example, of bores 14 in both supporting rod parts and by means of pin 15 which is insertable into bores 14, a fixation of the supporting rod portions 4b10, 4b11 is made possible at a definite extended position. The mutually slideable supporting rod parts 4b10 and 4b11 are provided with ar-

ticulating joint members 13 and 12 respectively. In this way, it is possible to shorten the height of the wreath stand from the operational position illustrated in FIGS. 1 and 2; that is, the articulating joint member 12 with its frames 4c, 4c' is movable up to a stop at articulating member 13, so that an intermediate position according to FIG. 3 is obtainable. As already mentioned, by means of this intermediate position, the supporting surfaces of the wreath stand can be reduced or the stand is placed in position for collapsing the same into the position shown in FIG. 4.

The displaceability of the supporting rod parts 4b11, 4b10 and their articulating joint members 12 and 13 with respect to each other can also serve to adjust the position of the upper supporting surface II at various levels of elevation. It is especially advantageous if the frames 4b, 4a, 4a', 4c' are configured as tubular rectangular frames closed upon themselves because then joining of the frames in the articulating joints 12, 13 is made especially simple as will be explained below.

The supporting surface means 5 of the respective frames 4 constitute, as illustrated, a transparent lattice which can be made of synthetic material or of a wire net. If the frames 4 are made of metal, for example, steel tubing, it is preferable to use a wire net 5a which is weldable to the rods of the frame.

In making of the articulating joint members 12, 13, hinge sleeves are used which can be slid into place over the frame tubes 4' lying at the corresponding pivot axis. At the region of these hinge sleeves 16, the wire net 5a for the pertinent frame is interrupted so that the frame may be moved in a swing motion. The hinge sleeves 16 are joined with the vertical supporting rod parts 4b11 or 4b10 by means of horizontal hinge plates 17. For the illustrated case of symmetrical frame pairs in each supporting level I, II, the hinge sleeve pairs 16 can be attached by means of a hinge plate pair common to both sleeves which overlaps and/or underlaps the hinge sleeves. The hinge sleeve pairs are at each level and at both sides of the supporting rods 4b1 so as to be mutually adjacent.

The hinge plate pair 17, 17 are penetrated by the supporting rod parts 4b11 and 4b10 respectively and are welded to these parts. The upper frames 4a, 4a' are easily disassembled by means of their hinge sleeves with reference to the appertaining hinge plate pairs 17, 17 and are again mountable for the purpose of accommodating a smaller number of wreaths or a larger number of wreaths respectively. In this instance, for a smaller number of wreaths, both upper frames 4a, 4a' do not have to be collapsed or folded up as shown in FIG. 3, instead, they can be removed entirely. For example, it is possible to provide the hinge plate pairs with a longitudinal bead which snaps the sleeve 16 when the upper frame part is horizontally installed over the sleeves 16.

The upper and lower supporting surfaces of the wreath stand according to FIG. 1 can be loaded with a total of twelve wreaths if three wreaths are allocated per frame, see FIG. 5. The wreath hooks 6 are attached to the upper longitudinal rod 4b2 of the base frame 4b and to the transverse rods at the end faces of the upper frames 4a, 4a'. These hooks 6 are suitable for hanging 12 additional wreaths. If one arranges the wreaths so as to partially lie one on top of the other, more than 24 wreaths can be placed on the wreath stand according to FIGS. 1, 2, 5 and 6.

The wreath stand of FIG. 3 can hold a maximum of 14 wreaths when placed on a normal arrangement. The lattice or wire netting 5a advantageously used to receive flowers, sprays or bunches or the like. In order to increase the supporting surface of the stand, and for anchoring the stand tightly in the earth, the supporting legs 8 of the wreath stand are provided with supporting feet 18 in the form of plates positioned at an incline with the earth, see especially FIG. 1. In order to move the wreath stand into its operational position, rollers which can be swung out are attached to the feet (not shown). In addition, the rollers 19 can be attached underneath the hinge plates 17 of the articulating joint member 12 which makes it possible to move the collapsed or folded wreath stand away by means of rollers.

In FIGS. 1 to 3a, reference numeral 90 designates dashed lines which represent additional lines by means of which the standing stability and the stability in the presence of wind of the stand are improved. These additional lines 90 can be anchored at the frames 4a, 4c in the same manner as lines 9, 9a, that is, by means of loops and eyelets which grasp the frame parts and hook onto corresponding hooks 11 respectively.

In FIG. 2, the additional lines 90 are provided double on each side of the wreath stand, so that these lines can be used in the event of a change of the wreath stand to the configuration shown in FIG. 3 or 3a for connecting the lower frames 4c, 4c' with the upper frame 4b2. The length of the doubled line 90 of FIG. 2 is not difficult to determine so that its length is sufficient in the fully stretched condition according to FIGS. 3, 3a. The reference numerals for FIGS. 3 and 3a correspond where like parts are illustrated.

FIG. 3a illustrates an additional line 90 in a more precise illustration for which the tension device 91 is connected into the line at about mid-length. Device 91 is also provided for line 9 as well. The tension device 91 can be in the form of a screw sleeve which has a righthand winding designated 91a and a lefthand winding 91b. By turning the tension member in the clockwise direction, a tensioning of the lines 9, 90 is obtained and by turning in the counter-clockwise direction, the lines 9, 90 can be loosened. Also in FIG. 3a, there are shown vertical joining plates 17a for the upper sleeve plate 17. Joining plate 17a are necessary to join the upper and lower hinge plates 17 of articulating joint members 13 with each other, because the dismantlement of the upper frames 4a, 4a' cannot be achieved by means of the hinge sleeve 16.

In order to simplify FIGS. 5 and 6, the lines 9, 90, 9a as well as a portion of the hooks 6 have been omitted. In addition, only those frames and lattices are shown which are of interest and the frames and lattices which would otherwise be viewable beneath or behind the frames and lattices toward the observer are omitted.

As a material for the tubes or frame parts, steel tubing may be used to which has been applied a rust preventive material. The same material, that is, steel wire, can be used for the lattice 5. It is also possible and advantageous to use stainless steel or in general, a non-rusting material such as aluminum. In addition, if the frame and lattice are made of metal, they can be coated with plastic for the protection against rust and/or to obtain a desired coloring for the stand. Finally, it is possible to fabricate the frame portions and lattices of the

wreath stand of a suitable plastic; this has the special advantage of affording a light weight.

With reference to the embodiment of FIGS. 7 to 9, the same reference numerals are used for the same parts appearing in FIGS. 1 to 6. The frames of the lower supporting level I are, however, here designated by number 4.1 and an additional frame is designated by 4.3. The supporting rods 4.4 are not configured here as closed frames, instead, they consist of several supporting rod parts which are insertable in each other. Specifically, the basic supporting rod 4.41 which is slideably borne in a tube sleeve of the articulating joint member 12 and a third supporting rod piece which serves for placing the additional frame 4.3 in a vertical plane on top of the supporting rod parts 4.41 and 4.42 will be more fully explained below.

FIG. 7 illustrates a third embodiment of the invention wherein the operational position of the frames is not fixed by means of a line, rather, for this purpose articulated struts are provided. The individual support rods 4.41 are provided with elbow lever articulating joints 21 at their lower ends facing the ground. And a pair of elbow lever struts extends from each of the elbow lever articulating joints 21 up to the respective outer longitudinal tubes 4.11 of the lower frame 4.1; these struts are articulately connected on these outer longitudinal tubes. As illustrated in FIG. 7, the extended position of the elbow lever 21 serves to fix the opened operational position of the lower frame pair 4.1, 4.1. In this position, the respective supporting rods 4.41 with a ring projection 4.44 (see especially FIG. 9) hit a stop at the lower frame articulating member 12, that is at the tube sleeve thereof. In the folded position of the elbow lever pairs 22, 22 (FIG. 9), the support rods 4.41 have been pushed through the lower frame joint 12 and the transverse struts 4.12 of the lower frame 4.1 the support rod 4.41 and the elbow lever 22, 22 lie practically axially parallel to each other in a position requiring very little storage space.

Referring to FIGS. 7 and 9 elbow lever articulating joint 21 comprises a housing 21.1 with two turning pins 21.2 journaled therein. The inner ends of the elbow lever 22 are linked to these turning pins and the housing has a U-shaped opening 21.3 at each outward side which makes possible the elbow lever motion from the operational into the collapsed or folded position. The supporting rod 4.41 is attached to the housing preferably by welding.

Comparing FIGS. 7 and 8, the additional frame 4.3 is mountable on the support rods 4.41 carried by the lower frames 4.1 such that the plane 5 of the additional frame is in the vertical or horizontal position. In the horizontal position, the additional frame 4.3 expands the wreath stand to make it a two-level stand. In its vertical position, the additional frame constitutes a hanging or carrying structure for wreaths, and if necessary, for other floral arrangements, the structure extending over the first support level I (FIG. 7). For this purpose, the additional frame 4.3 is provided with mounting sleeves 4.43 on its longitudinal tubes 4.32 and with mounting tubes 4.31 on its transverse tubes 4.34. The upper longitudinal tube 4.32 of the additional frame 4.3 is provided with wreath hooks 6.1 and 6.2 which are swingable outwardly from the frame plane 5; these hooks serve for accommodating wreaths hung thereon. The wreath hooks 6.1 are pivotly mounted as a one arm levers at the ends of the upper longitudinal tube 4.32

and the wreath hooks 6.2 are pivotly mounted as double arm levers at pivot locations 6.3 over the length of the upper longitudinal tube 4.32 so that wreaths can be hung on both sides of the frame plane 5.

The plates 18.1 are joined via the joining locations 26 with the respective elbow levers or struts 22 so that the elbow lever 22 can be pivoted on the lower longitudinal tubes 4.11. In this way, the lower frames 4.1 together with their support rod parts 4.41 can be collapsed into the position illustrated in FIG. 9. In this position only a small storage space is needed for the collapsed wreath stand or the stand can be easily transported by means of rollers.

In the embodiments of FIGS. 7 to 9, the lattice of the supporting planes which are interrupted to facilitate viewing are made of a non-rusting superior alloy steel mesh or wire and all other parts of the wreath stand such as tubes, linkages and feet are made of superior alloy steel, so that the stand requires practically no maintenance and over an extended period of time the stand is useful and has a good appearance. In special situations, if for example the wreath stand of FIG. 7 should be movable in this operational position, swing-out rollers can be secured to its plates 18.1 with little effort.

FIG. 10 illustrates an embodiment of the stand according to the invention having frames of approximately the same size 30, 31 and 32; these frames are made of aluminum tubes having a four-edged section and are provided for strength with transverse struts arranged crosswise. The struts also serve as a supporting surface for the wreaths and are likewise made of aluminum tubing. The lower frames 30 and 31 which span the grave over its entire length are equipped with self-locking hinges 33 such that they open only to an angle of 90 degrees and are then fixedly positioned with respect to each other so that no further tension means is required.

The upper frame 32 arranged vertically is mounted with holding tubes on bolts attached to the upper parts of the self-holding hinges 33. For hanging the wreaths, transverse struts 36 are mounted on the upper frame 32 and can be swung out from the plane of the frame 32. The transverse struts are provided with pins 41 at their ends for holding wreaths. Additionally, the lower frame pairs 31, 32 can carry transverse struts 38 at their upper sides which also are pivotable outwardly. These struts 38 can be joined by hinges with the upper longitudinal rods, these hinges being similar to the hinges at the front and back ends of the frame. The stand according to the invention takes very little space in its folded position. With this stand, the two lower frame parts can be used alone. There can also be provided additional horizontal support surfaces as described, for example, for the embodiment according to FIG. 1.

The self-holding hinge 33 comprises two U-shaped hinge members 33a, 33b which are riveted to the inner side of the two lower frames 30, 31 respectively so as to be mutually adjacent. A through-bolt 33d and U-shaped hinge members 33a, 33b conjointly define the self-holding hinge 33. A U-shaped yoke 33c is placed from above over the two U-shaped hinge members 33a, 33b. As shown in FIG. 11, a stud 34a is mounted on the yoke 33c. To provide a tight hold for the tube 34 (FIG. 10) for mounting the upper frame 32 on the stud 34a, the yoke 33c is tightly joined by fasteners 50 with a U-shaped hinge member 33a of the hinge members 33a,

33b attached to respective frames 30, 31, so that a lateral collapse of the strand is prevented. Referring to FIGS. 11 and 11a, the self-holding hinge is realized in that the upper edge 33e of the inner lying U-shaped hinge member 33b attached to the frame 31 lies against the inner surface 33f of the U-shaped hinge member 33a, the hinge member 33a being attached to the other frame 30, so that the stand cannot open any wider.

We claim:

1. A stand upon which can be placed floral arrangements such as wreaths, sprays and the like for decorating a burial site such as a coffin, grave or tomb, said stand comprising at least two frames having respective surface means for supporting a portion of the floral arrangements above the burial site, at least two hinges for hinge connecting said frames directly to each other so that said frames can be rotated relative to each other between a compact transportable position wherein said frames are disposed side by side and an operational position wherein said frames are angularly separated to conjointly straddle the burial site at a predetermined separation angle, each one of said hinges including two hinge members fixedly attached to respective ones of said two first-mentioned frames, said hinge members having respective surfaces for mutually engaging at said separation angle to prevent said frames from angularly separating any further, said frames conjointly defining a roof-like supporting deck spanning the burial site and extending outwardly so as to fall off at a downwardly inclined angle so that said frames brace the stand on the burial side in said operational position, and an additional frame for holding the remainder of the floral arrangements above the burial site, each one of said frames being configured to have substantially the same size and shape as the remaining ones of said frames to permit said additional frame to support the wreaths and sprays of said remainder of the floral arrangements in substantially the same spatial relationship with respect to each other as the wreaths and sprays of the said portion of the floral arrangements are supported on said two first-mentioned frames, said hinges comprising mounting means fixedly mounted thereon for receiving and removably mounting said additional frame above said two first-mentioned frames.

2. The stand of claim 1, each of said frames comprising tubing closed upon itself so as to define a rectangular frame figure.

3. The stand of claim 2, said surface means being a transparent lattice.

4. The stand of claim 3, said lattice consisting of struts rigidly joined to said tubing and arranged crosswise in said frame figure.

5. The stand of claim 1, said mounting means being two stud portions fixedly mounted on said hinges respectively.

6. The stand of claim 5, each of said stud portions being mounted on one of the hinge members of a corresponding one of said hinges in a position with respect to said one hinge member so as to cause said stud portions to extend in the vertical direction when said stand is in said operational position.

7. The stand of claim 1 comprising carrying means on said additional frame for carrying a portion of the wreaths and other floral arrangements.

8. The stand of claim 7, said carrying means being a plurality of wreath hooks pivotally mounted on said ad-

9

ditional frame so as to be swingable out from the plane thereof.

9. A stand upon which can be placed floral arrangements such as wreaths, sprays and the like for decorating a burial site such as a coffin, grave or tomb, said stand comprising at least two frames having respective surface means for supporting the floral arrangements above the burial site, at least two self-locking hinges for hinge connecting said frames directly to each other so that said frames can be rotated relative to each other between a compact transportable position wherein said frames are disposed side by side and an operational position wherein said frames are angularly separated to conjointly straddle the burial site at a predetermined separation angle, said frames conjointly defining a roof-like supporting deck spanning the burial site and extending outwardly so as to fall off at a downwardly inclined angle so that said frames brace the stand on the burial site in said operational position, and an additional frame for holding a portion of the floral arrangements above the burial site, said self-locking hinges comprising mounting means fixedly mounted thereon for receiving and removably mounting said additional frame above said two first-mentioned frames, said

10

mounting means being two stud portions fixedly mounted on said hinges respectively, said stud portions being mounted on said hinges in a position with respect to the same so as to cause said stud portions to extend in the vertical direction when said stand is in said operational position, each of said self-locking hinges including two U-shaped hinge members fixedly attached to respective ones of said two first-mentioned frames, a yoke having a corresponding one of said stud portions mounted thereon and being rigidly mounted to one of said two U-shaped members, said yoke being mounted on said one U-shaped member in a position to cause said stud portion to extend in the vertical direction when said stand is in said operational position, and a through-bolt for pivotally holding said two U-shaped members to each other, the other one of said U-shaped members being disposed within said one U-shaped member and having an upper edge contacting the inside of said one U-shaped member when the stand is placed in said operational position thereby fixing said predetermined angle and preventing said frames from angularly separating any further.

* * * * *

25

30

35

40

45

50

55

60

65