



Europäisches Patentamt
European Patent Office
Office européen des brevets



(11) **EP 1 048 610 A2**

(12) **EUROPEAN PATENT APPLICATION**

(43) Date of publication:
02.11.2000 Bulletin 2000/44

(51) Int Cl.7: **B67D 5/04**

(21) Application number: **99850055.7**

(22) Date of filing: **01.04.1999**

(84) Designated Contracting States:
**AT BE CH CY DE DK ES FI FR GB GR IE IT LI LU
MC NL PT SE**
Designated Extension States:
AL LT LV MK RO SI

(72) Inventor: **Larsson, Bengt**
274 53 Skivarp (SE)

(74) Representative: **Perklev, Karin Cecilia et al**
AWAPATENT AB,
P.O. Box 5117
200 71 Malmö (SE)

(30) Priority: **01.04.1999 SE 9801143**

(71) Applicant: **DRESSER WAYNE AB**
S-200 61 Malmö (SE)

(54) **Devices and method for refuelling**

(57) A device and a method for directing the gas flow in a gas return conduit to the fuel container of a fuel dispensing device when filling a motor vehicle with fuel are

disclosed. The device has a means in the vehicle, which communicates by magnetic interaction with a gas flow control means in the fuel dispensing device.

FIG 4

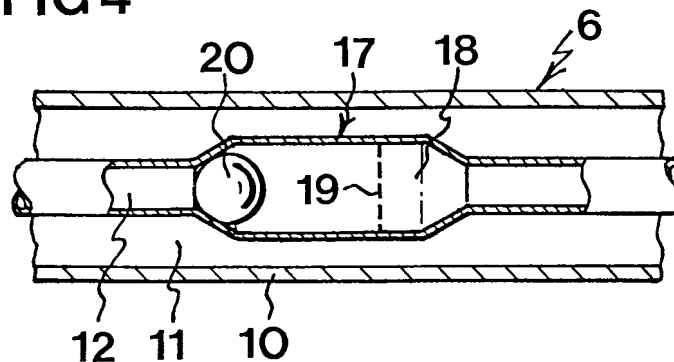

EP 1 048 610 A2

Description

Technical Field

[0001] The present invention relates generally to devices and a method for controlling a gas flow in connection with refuelling.

Background Art

[0002] When putting gasoline and other liquid fuel into motor vehicles, especially cars, it is desirable to prevent, as much as possible, fuel vapours from escaping into the ambient air. As a rule, a so-called gas return conduit is therefore coaxially arranged inside or outside the hose which conducts fuel from a fuel container via the fuel dispenser to the car. When a certain volume of fuel has been put into the tank of the car, the gas return conduit conducts a corresponding volume of gas back to the fuel container. Normally this volume of gas consists of between 70% and 100% of saturated fuel vapours, i. e. different types of hydrocarbons.

[0003] In the normal driving of a car, additional fuel vapours form in the tank, for instance, as the fuel splashes to and fro. To prevent these vapours from being passed directly to the surroundings, so-called charcoal canisters are now installed in new cars. A charcoal canister can fundamentally be described as a charcoal filter which is in contact with the fuel tank, the car engine and the ambient air. Fuel vapours from the tank are discharged to the ambient air through the charcoal canister, a large amount of the hydrocarbons getting caught in the filter. When air from the surroundings is injected into the engine, also this air passes through the charcoal filter and absorbs a large amount of the hydrocarbons that have previously got caught in the filter but are now entrained to the engine to be burnt. This means that cars that are equipped with charcoal canisters are more environmentally friendly than cars without a charcoal canister.

[0004] In cars equipped with charcoal canisters, a liquid seal is positioned between the filling hole and the tank of the car to prevent the fuel vapours from being discharged to the surroundings this way during the refuelling. Instead the vapours are forced out through the charcoal canister. Therefore clean air from the surroundings will be sucked back via the gas return conduit into the fuel container when filling up cars equipped with a charcoal canister. This air contains extremely small amounts of hydrocarbons. Liquid fuel in the fuel container will therefore be dissolved in the air until this has become saturated. During this process, the air in the fuel container expands. With a view to preventing positive pressure, the extra volume of fuel vapours is discharged through a valve to the ambient air. Consequently part of the environmentally friendly effect which was to be achieved by using charcoal canisters will be lost.

[0005] There is thus a need for filling up vehicles, with

or without a charcoal canister, while taking environmental aspects into consideration as much as possible. Moreover, authorities such as the California Air Resource Board require that cars and other vehicles should allow refuelling in an environmentally friendly manner, independently of whether they are equipped with a charcoal canister or not.

Summary of the Invention

[0006] An object of the present invention therefore is to provide a simple solution to the problems above in connection with refuelling, environmental aspects being taken into consideration as much as possible while at the same time the authorities' requirements are satisfied.

[0007] According to the invention, this object is achieved by devices having the features stated in appended claims 1, 8 and 11. Preferred embodiments are defined in the subclaims. The object is also achieved by a method according to appended claim 13.

[0008] The invention is based on the idea that it should be possible to use the same fuel dispensing device for vehicles with or without a charcoal canister by the return of gas to the fuel container being controlled depending on whether the vehicle has a charcoal canister or not. According to the invention, such control can be carried out with the aid of a gas flow control means for controlling the gas flow in the gas return conduit, said gas flow control means being actuatable, by magnetic interaction, with the aid of a means in the vehicle. As a result, the gas flow control means can keep the gas return conduit essentially open in vehicles without a charcoal canister and essentially closed in vehicles having a charcoal canister. An advantage of this arrangement is that the fuel dispensing device can control the return of gas to the fuel container automatically without the person filling up the car making any operation, thus achieving increased reliability. Since the actuation made by the gas flow control means occurs in a contactless manner, also the risk of mechanical problems decreases. Owing to the use of magnetic interaction, neither mechanical nor electric switches need be used, which is a great advantage in the environment where the invention is to be used.

[0009] In a preferred embodiment, the gas flow control means comprises a movable component which, under the action of the means in the vehicle, is movable from a first to a second position for controlling the gas flow in the gas return conduit. This action could be both direct, i.e. directly move the movable component, or indirect, i.e. move a second component that activates the movable component. If one chooses to provide all vehicles having a charcoal canister with a means that actuates the gas flow control means, the gas return conduit is open in the first position of the movable component and closed in the second position. It is also possible to provide all vehicles without a charcoal canister with a

means that actuates the gas flow control means, in which case the gas return conduit is closed in the first position of the movable component and open in the second position. Preferably the movable component is directly actuatable by the means in the vehicle, so that the gas flow is quickly shut off when desired.

[0010] To make it possible for gas to pass the movable component in the cases where a return of gas is desirable, the movable component is enclosed in an enlarged portion of the gas return conduit.

[0011] Since in the preferred embodiment, the gas return conduit is essentially circular in cross-section, the enlarged portion is formed of a radial expansion along a section of the gas return conduit. In this case the movable component is a ball of a magnetic material since this enables easy shutting-off of the conduit, without necessitating special consideration of the geometry. By magnetic material is here meant ferromagnetic or ferromagnetic materials.

[0012] To achieve optimal conditions for magnetic interaction between the means in the fuel dispensing device and those in the vehicle, the gas flow control means is preferably accommodated in the delivery nozzle, i.e. that part of the device which, when refuelling, is positioned closest to the filling hole of the vehicle.

[0013] According to another aspect of the invention, the gas flow in the gas return conduit is controlled with the aid of a magnetic means which is adapted to be mounted in the vehicle and to actuate the gas flow control means by magnetic interaction, so that the conductivity of the gas return conduit changes. This provides a possibility of automatically distinguishing the vehicles in which a return of gas is not desired from the vehicles in which a return of gas is desired, or automatically distinguishing vehicles for some other purpose.

[0014] The invention also concerns vehicles which comprise a magnetic means for controlling the gas flow in the gas return conduit. In a variant of the invention, vehicles equipped with a charcoal canister are provided with a magnetic means which actuates the gas flow control means so that the gas return conduit is essentially closed. In a further variant of the invention, vehicles which are not equipped with a charcoal canister are provided with a magnetic means which instead actuates the gas flow control means to essentially open the gas return conduit. This variant is probably more convenient since this type of vehicle is likely to be less common in the future.

[0015] Preferably, the magnetic means in the vehicle consists of a permanent magnet which is mounted adjacent to the fuel filling hole of the vehicle. This results in a device which is both inexpensive and extremely easy to mount.

[0016] The invention can also be described as a method of controlling, when filling a vehicle with fuel, the gas flow in a gas return conduit for returning fuel vapours to a fuel container, comprising the step of actuating, by magnetic interaction, a gas flow control means in the

device for filling the vehicle with fuel, so that the conductivity of the gas return conduit changes.

Brief Description of the Drawings

[0017] The invention will be further described below by way of an embodiment with reference to the accompanying drawings, in which

- 10 Fig. 1 is a schematic view of a car, a fuel dispenser and a fuel container,
 Fig. 2 is a cross-sectional view along line A-A in Fig. 1 of a fuel hose with a gas return conduit,
 Fig. 3 is a schematic view of a charcoal canister and its connections, and
 15 Fig. 4 is a schematic cross-sectional view of a fuel hose with a gas flow control means.

Description of Preferred Embodiments

[0018] Fig. 1 illustrates a car 1 with a fuel tank 2, a charcoal canister 3 and a permanent magnet 4 which is arranged in connection with the fuel filling hole 5. During refuelling, fuel is conducted to the tank 2 of the car through a hose 6 from the fuel container 7 via the fuel dispenser 8. The fuel container 7 has a valve 9 to compensate for the positive or negative pressure generated in the tank 7.

[0019] Fig. 2 is a cross-sectional view of the hose 6 along line A-A in Fig. 1, said hose 6 having a casing 10 which encloses a duct 11 which conducts fuel to the car 1, and a coaxially arranged gas return conduit 12.

[0020] Fig. 3 is a schematic view of the charcoal canister 3 which consists of a charcoal filter 13 and has a connection 14 to the fuel tank, a connection 15 for sucking in air from the surroundings and a connection 16 to the engine.

[0021] Fig. 4 is a schematic cross-sectional view of that part of the fuel hose 6 in which the gas flow control means 17 is arranged. The gas flow control means 17 comprises a radial expansion 18 of a portion of the gas return conduit 12, said portion 18 being positioned in the delivery nozzle, i.e. that part of the hose 6 which is in contact with the car 1 during filling up. The expanded portion 18 contains a piece of mesh 19 and a movable component in the form of a ball 20 of a magnetic material which in Fig. 4 is drawn in the position where it essentially closes the gas return conduit 12 for returning gas.

[0022] In the preferred embodiment, a vehicle equipped with a charcoal canister 3 is provided with a permanent magnet 4 in the vicinity of the fuel filling hole 5. The magnet 4 is arranged so that when the delivery nozzle is inserted in the filling hole 5, attraction arises between the magnet 4 and the ball 20 in the gas flow control means 17. The ball 20 which normally is in a position between the indicated position and the piece of mesh 19 in Fig. 4 moves to the indicated position and thus shuts off the gas return conduit 12.

[0023] In another embodiment, a car 1 which is not equipped with a charcoal canister 3 is provided with a permanent magnet 4 in the vicinity of the fuel filling hole 5. The magnet 4 is arranged so that when the delivery nozzle is inserted into the filling hole 5, repulsion arises between the magnet 4 and the ball 20 in the gas flow control means 17. The ball 20 which in this case normally is in the indicated position in Fig. 4 then moves away therefrom and opens the gas return conduit 12.

[0024] It will be appreciated that a great number of modifications of the above embodiments of the invention are feasible within the scope of the invention as defined in the appended claims. For example, the gas flow control means can be designed in various ways. The magnet in the car need not, for instance, directly actuate the gas flow control means but can instead actuate a mechanical switch which closes and opens the gas return conduit. The positioning of the magnet in the car and of the gas flow control means may also vary.

[0025] An alternative solution to the problem with the return of gas could be to have information on the car stored on the credit card that is used in filling up. The credit card would then indicate to the fuel dispenser whether there is a gas return requirement, in which case a means in the dispenser controls the return of gas as desired.

[0026] A further alternative solution is that a mechanically actuatable gas flow control means is arranged in that part of the fuel dispensing device which is in contact with the car during filling up. The area around the fuel filling hole of the vehicle, or the filling hole itself, is designed in such manner that when, during filling up, the delivery nozzle of the fuel filling is inserted into the filling hole, the gas flow control means is actuated mechanically, either directly or indirectly by the vehicle, the return of gas to the fuel container being controlled. A conceivable embodiment to achieve this function could be a bellows which is arranged around the front part of the delivery nozzle and which is in contact with a gas flow control means in the gas return conduit. When the bellows is pushed together, the conductivity of the gas return conduit changes as desired.

Claims

1. A device for filling a motor vehicle (1) with fuel, comprising a gas return conduit (12) for returning fuel vapours to a fuel container (7), characterised by a gas flow control means (17) for controlling the gas flow in the gas return conduit (12), said gas flow control means (17) being actuatable, by magnetic interaction, with the aid of a means (4) in the vehicle (1).
2. A device as claimed in claim 1, wherein the gas flow control means (17) comprises a movable component (20) which, under the action of the means (4)

in the vehicle (1), is movable from a first to a second position for controlling the gas flow in the gas return conduit (12).

3. A device as claimed in claim 2, wherein the movable component (20) is enclosed in an enlarged portion (18) of the gas return conduit (12).
4. A device as claimed in claim 3, wherein the enlarged portion (18) is a radial expansion along a section of the gas return conduit (12).
5. A device as claimed in any one of claims 2-4, wherein the movable component (20) is a ball of a magnetic material.
6. A device as claimed in any one of the preceding claims, wherein the gas flow control means (17) is accommodated in that part of the device which is positioned closest to the filling hole (5) of a vehicle (1) when refuelling.
7. A device as claimed in claim 6, wherein the gas flow control means (17) is accommodated in a delivery nozzle.
8. A device for controlling the gas flow in a gas return conduit (12) for returning fuel vapours to a fuel container (7) when filling a vehicle (1) with fuel, **characterised** by a magnetic means (4) which is adapted to be mounted in the vehicle (1) and to actuate a gas flow control means (17) by magnetic interaction, so that the conductivity of the gas return conduit (12) changes.
9. A device as claimed in claim 8, wherein the magnetic means (4) is a permanent magnet.
10. A device as claimed in claim 8 or 9, wherein the magnetic means (4) is mounted adjacent to the fuel filling hole (5) of the vehicle (1).
11. A vehicle, **characterised** in that it comprises a device according to any one of claims 8-10.
12. A vehicle (1) according to claim 11, comprising a charcoal canister (5), the device being adapted to actuate the gas flow control means (17) so that the gas return conduit (12) is essentially closed.
13. A method of controlling, when filling a vehicle (1) with fuel, the gas flow in a gas return conduit (12) for returning fuel vapours to a fuel container (7), comprising the step of
 - actuating, by magnetic interaction, a gas flow control means (17) in the device for filling the vehicle (1) with fuel, so that the conductivity of

the gas return conduit (12) changes.

5

10

15

20

25

30

35

40

45

50

55

5

FIG 1

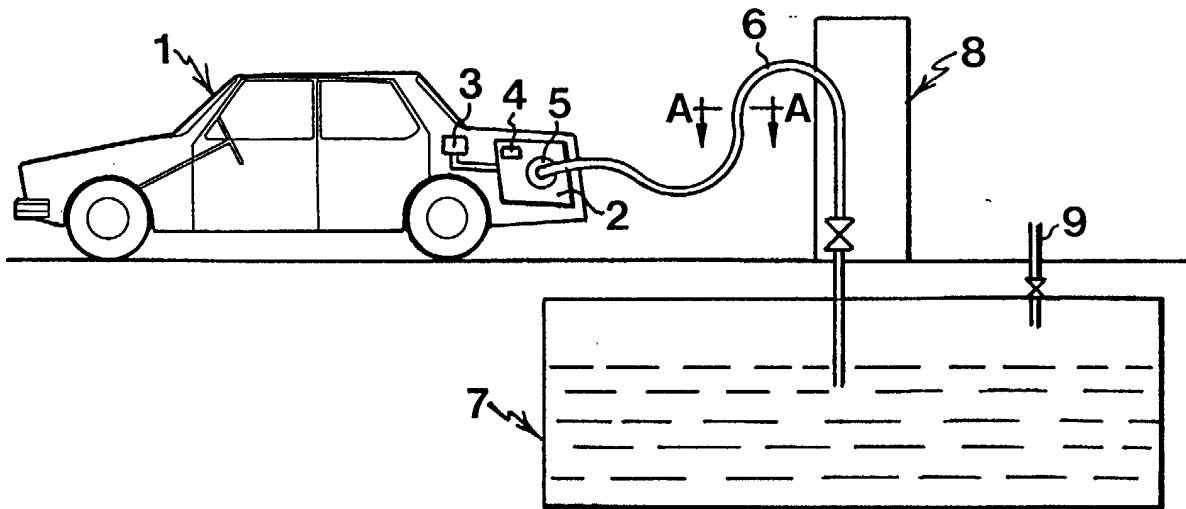

FIG 2

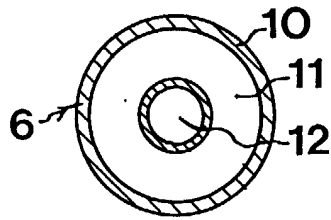

FIG 3

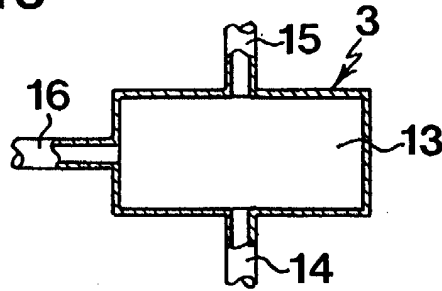

FIG 4

