

(19) World Intellectual Property Organization
International Bureau



(43) International Publication Date
18 February 2010 (18.02.2010)

PCT

(10) International Publication Number
WO 2010/018902 A1

(51) International Patent Classification:
B60L 11/18 (2006.01)

(74) Agent: **KIM, Jong Il**; KIM's Patent Attorney Office,
Room #111, Bonbudong, Gwangju Technopark, Dae-
chon-dong, Buk-gu, Gwangju-si 500-706 (KR).

(21) International Application Number:
PCT/KR2008/007550

(81) Designated States (unless otherwise indicated, for every
kind of national protection available): AE, AG, AL, AM,
AO, AT, AU, AZ, BA, BB, BG, BH, BR, BW, BY, BZ,
CA, CH, CN, CO, CR, CU, CZ, DE, DK, DM, DO, DZ,
EC, EE, EG, ES, FI, GB, GD, GE, GH, GM, GT, HN,
HR, HU, ID, IL, IN, IS, JP, KE, KG, KM, KN, KP, KZ,
LA, LC, LK, LR, LS, LT, LU, LY, MA, MD, ME, MG,
MK, MN, MW, MX, MY, MZ, NA, NG, NI, NO, NZ,
OM, PG, PH, PL, PT, RO, RS, RU, SC, SD, SE, SG, SK,
SL, SM, ST, SV, SY, TJ, TM, TN, TR, TT, TZ, UA, UG,
US, UZ, VC, VN, ZA, ZM, ZW.

(22) International Filing Date:
19 December 2008 (19.12.2008)

(25) Filing Language: Korean

(26) Publication Language: English

(30) Priority Data:
10-2008-0078924 12 August 2008 (12.08.2008) KR

(71) Applicant (for all designated States except US): **TOP
R&D CO., LTD** [KR/KR]; Room #302, Venture Support
Center, Gwangju Technopark, Daechon-dong, Buk-gu,
Gwangju-si 500-706 (KR).

(84) Designated States (unless otherwise indicated, for every
kind of regional protection available): ARIPO (BW, GH,
GM, KE, LS, MW, MZ, NA, SD, SL, SZ, TZ, UG, ZM,
ZW), Eurasian (AM, AZ, BY, KG, KZ, MD, RU, TJ,
TM), European (AT, BE, BG, CH, CY, CZ, DE, DK, EE,
ES, FI, FR, GB, GR, HR, HU, IE, IS, IT, LT, LU, LV,
MC, MT, NL, NO, PL, PT, RO, SE, SI, SK, TR), OAPI
(BF, BJ, CF, CG, CI, CM, GA, GN, GQ, GW, ML, MR,
NE, SN, TD, TG).

(72) Inventor; and

(75) Inventor/Applicant (for US only): **KIM, Gyu Ha**
[KR/KR]; 118-603, Samsung APT, Unnam-dong,
Gwangsan-gu, Gwangju-si 506-755 (KR).

[Continued on next page]

(54) Title: ELECTRIC CAR

【Figure 1】

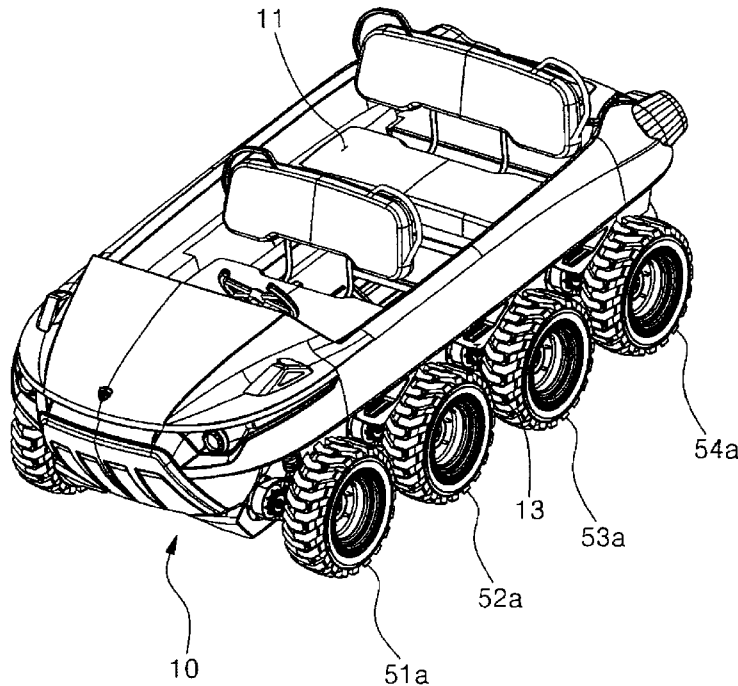

(57) Abstract: An electric car is disclosed, which is basically configured to allow a plu-
rality of driving motors to separately drive the wheels of a vehicle, and part of the driv-
ing motors can be driven when a driving load is small like on a flat ground, and all
the driving motors are driven when the vehicle runs on a slope or a tough road in
which a vehicle speed is slow due to a large driving load. Namely, the driving force of
driving motors can be controlled depending on a varying load in such a manner that only
a needed driving torque is outputted depending on a change of loads for thereby
minimizing a consumption of charged electric power.

WO 2010/018902 A1

Published:

— *with international search report (Art. 21(3))*

【DESCRIPTION】**【Invention Title】**

ELECTRIC CAR

【Technical Field】

<1> The present invention relates to an electric car, and in particular to an electric car which is basically configured to allow a plurality of driving motors to separately drive the wheels of a vehicle, and part of the driving motors can be driven when a driving load is small like on a flat ground, and all the driving motors are driven when the vehicle runs on a slope or a tough road in which a vehicle speed is slow due to a large driving load. Namely, the driving force of driving motors can be controlled depending on a varying load in such a manner that only a needed driving torque is outputted depending on a change of loads for thereby minimizing a consumption of charged electric power.

<2>

【Background Art】

<3> In recent years, a method for generating a desired driving force using an electric motor is more widely used owing to its convenience and environment friendly operation as compared to a method for using a gasoline engine.

<4> However, when an electric motor is used, it is needed to configure a vehicle to generate enough performance with respect to a large driving load. In this case, a consumption of driving force unnecessarily increases, so the charged power is fast consumed, which leads to decreasing a shorter running time.

<5>

【Disclosure】**【Technical Problem】**

<6> Accordingly, it is an object of the present invention to provide an electric vehicle which is basically configured to allow a plurality of

driving motors to separately drive the wheels of a vehicle, and part of the driving motors can be driven when a driving load is small like on a flat ground, and all the driving motors are driven when the vehicle runs on a slope or a tough road in which a vehicle speed is slow due to a large driving load. Namely, the driving force of driving motors can be controlled depending on a varying load in such a manner that only a needed driving torque is outputted depending on a change of loads for thereby minimizing a consumption of charged electric power.

<7>

【Technical Solution】

<8> To achieve the above objects, in an electric car which includes wheels disposed in left and right sides of a car body for running operations, and a driving force device for generating a driving force for driving wheels using electric power, there is provided an electric car which comprises the wheels provided in the front and rear sides of the car body in at least two rows in each side; the driving device which includes a first driving motor and a second driving motor, and a first driving force transfer unit and a second driving force transfer unit for transferring the outputs of the first and second driving motors to the wheels of a front row and the wheels of a rear row, respectively; and a control unit which is configured to drive either the first driving motor or the second driving motor and is configured to drive both the first driving motor and the second driving motor when the speed of a car is lower than a set level as compared to an output torque of the currently driven motor between the first and second driving motors.

<9> The car body is configured to run on a water surface, and includes a water surface running device for running on a water surface, and the water surface running device includes a left and right underwater motors provided in the left and right sides of a rear end of the car body, a screw connected with a rotation shaft of each of the left and right underwater motors, and a lifting and lowering unit for lifting and lowering the underwater motors in the upward and downward directions, and the lifting and lowering unit is

configured to lift the underwater motors in the upward direction when a ground running mode is selected, and to lower the underwater motors when the water surface running mode is selected, so the underwater motors remain underwater.

<10> The lifting and lowering unit includes a slide bar having a lower end connected with the underwater motor and being supported by the car body to slide in the upward and downward directions, and a straight motion unit for moving the slide bar in the upward and downward directions.

<11> A screw is provided in an upper side of the slide bar, and the straight motion unit includes a rotor having a female thread formed in the center and engaged to a male thread, and a stator which surrounds an outer side of the rotor and generates a rotational force with respect to the rotor along with the rotor.

<12>

【Advantageous Effects】

<13> With the above construction, the electric car according to the present invention is disclosed, which is basically configured to allow a plurality of driving motors to separately drive the wheels of a vehicle, and part of the driving motors can be driven when a driving load is small like on a flat ground, and all the driving motors are driven when the vehicle runs on a slope or a tough road in which a vehicle speed is slow due to a large driving load. Namely, the driving force of driving motors can be controlled depending on a varying load in such a manner that only a needed driving torque is outputted depending on a change of loads for thereby minimizing a consumption of charged electric power.

<14>

【Description of Drawings】

<15> Figure 1 is a perspective view illustrating an electric car according to an embodiment of the present invention.

<16> Figure 2 is a perspective view illustrating an electric car according to an embodiment of the present invention.

<17> Figure 3 is a perspective view illustrating a state that a body surface of an electric car is transparent for an easier understanding according to an embodiment of the present invention.

<18> Figure 4 is a front view illustrating a front view illustrating an electric car according to an embodiment of the present invention.

<19> Figure 5 is a back view illustrating a front view illustrating an electric car according to an embodiment of the present invention.

<20> Figure 6 is a plane view illustrating a front view illustrating an electric car according to an embodiment of the present invention.

<21> Figure 7 is a side view illustrating a front view illustrating an electric car according to an embodiment of the present invention.

<22> Figure 8 is a bottom view illustrating a front view illustrating an electric car according to an embodiment of the present invention.

<23> Figure 9 is a perspective view illustrating a body chassis with a body surface of an electric car being removed according to an embodiment of the present invention.

<24> Figure 10 is a perspective view illustrating a power train and a suspension device of an electric car according to an embodiment of the present invention.

<25> Figure 11 is a disassembled perspective view illustrating a partly disassembled construction of a power train and a suspension device of an electric car according to an embodiment of the present invention.

<26> Figure 12 is a disassembled perspective view illustrating a partly disassembled construction of a suspension device of an electric car according to an embodiment of the present invention.

<27> Figure 13 is a perspective view illustrating a suspension device of an electric car according to an embodiment of the present invention.

<28> Figure 14 is a perspective view illustrating a suspension device of an electric car according to an embodiment of the present invention.

<29> Figure 15 is a perspective view illustrating part of a suspension device of an electric car according to an embodiment of the present

invention.

<30> Figure 16 is a perspective view illustrating part of a suspension device of an electric car according to an embodiment of the present invention.

<31> Figure 17 is a side view illustrating an operation of a suspension device of an electric car according to an embodiment of the present invention.

<32> Figure 18 is a disassembled perspective view illustrating a suspension device of an electric car according to an embodiment of the present invention.

<33> Figure 19 is a concept block diagram illustrating a control unit of an electric car according to an embodiment of the present invention.

<34> Figure 20 is a concept side view illustrating a lifting and lowering operation of a water surface propulsion device of an electric car according to an embodiment of the present invention.

<35> Figure 21 is a perspective view illustrating a water surface propulsion device of an electric car according to an embodiment of the present invention.

<36>

【Best Mode】

<37> In an electric car which includes wheels disposed in left and right sides of a car body for running operations, and a driving force device for generating a driving force for driving wheels using electric power, there is provided an electric car, comprising the wheels provided in the front and rear sides of the car body in at least two rows in each side; the driving device which includes a first driving motor and a second driving motor, and a first driving force transfer unit and a second driving force transfer unit for transferring the outputs of the first and second driving motors to the wheels of a front row and the wheels of a rear row, respectively; and a control unit which is configured to drive either the first driving motor or the second driving motor and is configured to drive both the first driving

motor and the second driving motor when the speed of a car is lower than a set level as compared to an output torque of the currently driven motor between the first and second driving motors.

<38>

【Mode for Invention】

<39>

The preferred embodiments of an electric car according to the present invention will be described with reference to the accompanying drawings. The present invention will be described in more details while referring to an electric car which is able to run on a ground as well as a water surface.

<40>

Figure 1 is a perspective view illustrating an electric car according to an embodiment of the present invention. Figure 2 is a perspective view illustrating an electric car according to an embodiment of the present invention. Figure 3 is a perspective view illustrating a state that a body surface of an electric car is transparent for an easier understanding according to an embodiment of the present invention. Figure 4 is a front view illustrating a front view illustrating an electric car according to an embodiment of the present invention. Figure 5 is a back view illustrating a front view illustrating an electric car according to an embodiment of the present invention. Figure 6 is a plane view illustrating a front view illustrating an electric car according to an embodiment of the present invention. Figure 7 is a side view illustrating a front view illustrating an electric car according to an embodiment of the present invention. Figure 8 is a bottom view illustrating a front view illustrating an electric car according to an embodiment of the present invention. Figure 9 is a perspective view illustrating a body chassis with a body surface of an electric car being removed according to an embodiment of the present invention. Figure 10 is a perspective view illustrating a power train and a suspension device of an electric car according to an embodiment of the present invention. Figure 11 is a disassembled perspective view illustrating a partly disassembled construction of a power train and a suspension device of an electric car according to an embodiment of the present invention.

Figure 12 is a disassembled perspective view illustrating a partly disassembled construction of a suspension device of an electric car according to an embodiment of the present invention. Figure 13 is a perspective view illustrating a suspension device of an electric car according to an embodiment of the present invention. Figure 14 is a perspective view illustrating a suspension device of an electric car according to an embodiment of the present invention. Figure 15 is a perspective view illustrating part of a suspension device of an electric car according to an embodiment of the present invention. Figure 16 is a perspective view illustrating part of a suspension device of an electric car according to an embodiment of the present invention. Figure 17 is a side view illustrating an operation of a suspension device of an electric car according to an embodiment of the present invention. Figure 18 is a disassembled perspective view illustrating a suspension device of an electric car according to an embodiment of the present invention. Figure 19 is a concept block diagram illustrating a control unit of an electric car according to an embodiment of the present invention. Figure 20 is a concept side view illustrating a lifting and lowering operation of a water surface propulsion device of an electric car according to an embodiment of the present invention. Figure 21 is a perspective view illustrating a water surface propulsion device of an electric car according to an embodiment of the present invention.

<41> As shown in the drawings, the electric car according to the present invention comprises a car body 10, first and second driving devices 20 and 20', a suspension device 30, a steering device 40, wheels 51a, 51b, 52a, 52b, 53a, 53b, 54a and 54b, and a water surface running device 60.

<42> Here, the car body 10 forms a frame of a car in the same shape as an underneath shape of a ship for a smooth sliding on the surface of water with its underneath being sealed. A seat 11 is provided in the interior of the car body 10, so passenger can sit. An operation panel 12 having a meter panel and operation switches is provided in a front side of the car body. Steps 13 are provided at both sides of the car body 10, so passenger can step thereon when

getting on/off the car. Wheels 51a, 51b, 52a, 52b, 53a, 53b, 54a, and 54b are provided at both sides of the car body 10 in four rows totally, and a water surface running device 60 is provided in a rear end of the car body.

<43> The first and second driving devices 20 and 20' are configured to generate driving forces for thereby driving the wheels 51a, 51b, 52a, 52b, 53a, 53b, 54a, and 54b. In the embodiment shown in the drawing, it relates to an electric car type that is basically configured to generate rotational force from the driving motors 21 and 21' using the power charged in a battery 28. In the present invention, a second driving device 20' is provided as an auxiliary element. So, when load is larger as compared to the output from the first driving device 20, a certain output is obtained from the second driving device 20'. Namely, in the present invention, the first driving device 20 is connected with the wheels 51a, 51b, 52a and 52b, respectively, formed in two rows in the front side, and the second driving device 20' is connected with the wheels 53a, 53b, 54a and 54b, respectively, formed in two rows in the rear side. With the above construction, when load is not large like in a flat ground, the car can run with the output of the first driving device 20. When load is larger than a set level like in a tough road or a slope, the driving output can be increased by driving both the first and second driving devices 20 and 20'. The control unit controls the operations of the first and second driving motors 21 and 21' depending on the varying loads. The control unit 70 is configured to drive the second driving motor 21' when the speed of the vehicle based on the output torque of the first driving motor 21 is below than a set level as only the first driving motor 21 is driven. For example, the control unit 70 operates the first driving motor 21 depending on an acceleration signal of an acceleration pedal 72. As the load is large, when the speed of the car is lower than a set level as compared to the acceleration signal of the acceleration pedal 72, the control unit 70 controls the second driving motor 21' to operate. In the drawing, an embodiment for computing the speed of a car with the helps of a wheel revolution detection sensor 71 which outputs a speed signal by detecting the

revolution of wheels.

<44> As shown in the drawing, the first and second driving devices 20 and 20' comprise first and second driving motors 21 and 21' for receiving power charged in the battery 28 and outputting rotational force, a decelerator for decelerating the rotations of the first and second driving motors 21 and 21' and first and second driving force transfer units 22 and 22' having a differentiating device and a clutch for performing a differentiating function due to a revolution difference between the left and right wheels. The driving forces of the first and second driving devices 20 and 20' are transferred to the wheels 51a, 51b, 52a, 52b, 53a, 53b, 54a, and 54b formed in four rows. In the following, since the first driving device 20' is similar with the first driving device 20, the first and second driving devices 20 and 20' will be described with the helps of only the operation that the driving force is transferred from the first driving device 20 to the wheels 51a, 51b, 52a and 52b of two rows. The driving force transfer unit 22 is connected in left and right sides, respectively. Left and right size braking units 23a and 23b are installed in the left and right sides of the driving force transfer unit 22, respectively, for braking the wheels 51a, 51b, 52a and 52b of two rows of the front side of the car body.

<45> Here, the driving force transfer unit 22 is connected with a driving shaft 24b through the braking units 23a and 23b while corresponding to the wheels 52a and 52b positioned in the rear side among the wheels 51a, 51b, 52a and 52b of two rows of the rear side, and is connected with a driving shaft 24a by means of a chain driving unit 25, connected between driving shafts, while corresponding to the wheels 51a and 51b position in the front side among the wheels 51a, 51b, 52a and 52b formed in two rows of the front side. Namely, the chain driving unit 25 is connected between the driving shafts 24a and 24b connected with the wheels 51a, 51b, 52a and 52b formed of two rows of the front side, and the driving shaft 24b positioned in the rear side is connected with the driving force transfer unit 22 of the driving force device 20. The rotational force transferred to the driving shaft 24a is transferred

to the wheels 51a and 51b positioned in the front side among the wheels 51a, 51b, 52a and 52b of two rows of the front side through the driving force transfer unit 26 and the wheel shaft 27 provided in the suspension device 30. When a driver steps on the brake pedal 74 for stopping the car, the left and right braking units 23a and 23b operate concurrently, and when a driver rotates the steering handle 41 for steering, only the left side or right side operation is activated between the left and right braking units 23a and 23b.

<46> The suspension device 30 is formed in a trailing arm type. The present invention is so configured that the suspension device 30 is equipped with a construction for transferring a rotational force, transferred to the driving shaft 24a, to the wheels 51a and 51b. Here, the suspension device 30 comprises an arm shaft 31 engaged to the car body 10 at both sides of the car body 10, a trailing arm 32 with its one end being connected with the arm shaft 31 while rotating with respect to the arm shaft 31, and an absorbing unit 33 provided for absorbing the rotation of the trailing arm 32. The arm shaft 31 is fixed in a side portion of the car body 10 by engaging an engaging flange 311 to the car body 10 using bolts. An arm shaft hole 321 is provided in one end of the trailing arm 32 with the arm shaft 31 being inserted into the arm shaft hole 321. A wheel shaft hole 322 is formed in the other end of the same with the wheel shaft 27 being rotatably inserted into the wheel shaft hole. A connection unit 323 is provided in an upper side between both ends for connecting with a lower end of the absorbing unit 33. The absorbing unit 33 is provided to absorb impact applied from the wheel 51a and reduce vibrations, with its one end being connected with the connection unit 323 provided in the trailing arm 32, with the other end being connected with the car body 10.

<47> The wheels 51a and 51b are connected with the hub 271 of the wheel shaft as being integrally rotated along with the wheel 51a.

<48> The present invention is characterized in that the construction configured to transfer rotational force to the wheels 51a and 51b rotatably supported to the trailing arm 32 moving in upward and downward directions R

about the arm shaft 31 is integrally configured with the trailing arm 32. As shown in the drawings, the driving shaft 24a rotating by means of a rotational force transferred from the driving force transfer unit 22 is concentric with the arm shaft 31 and is inserted into the center of the arm shaft 31. The rotational force transferred from the driving device 20 is transferred to the driving shaft 24a, and the rotational force of the driving shaft 24a is transferred to the wheels 51a and 51b, namely, the wheel shaft 27 by means of the driving force transfer unit 26 provided in the trailing arm 32. In the drawings, it is shown that the driving force transfer unit 26 includes a chain 263 which connects the sprocket 261 provided in the driving shaft 24a and the sprocket 262 provided in the wheel shaft 27 connected with the wheels 51a and 51b. However, the above construction is not limited thereto. Namely, the driving force transfer unit might include a pulley which is provided in the other end of the driving shaft, and a belt which connects the pulley connected with the wheels. In addition, the driving force transfer unit might include a driving gear disposed in the other end of the driving shaft, a driven gear connected with the wheels, and a motored gear assembly engaged in the trailing arm for connecting the driving gear and the driven gear.

<49> The present invention is preferably characterized in that a driving force is transferred as the driving force transfer unit 26 rotates with respect to the arm shaft 31 integrally with the trailing arm 32 which rotates in the upward and downward directions R with respect to the arm shaft 31. The above operation can be possible as the driving shaft 24a is concentric with the arm shaft 31.

<50> The steering device 40 is basically configured to steer a car on a ground as well as a water surface and includes a steering handle 41 that a driver can rotate in left and right directions.

<51> On the ground, the steering device 40 is designed to operate based on the skid steering method for changing a running direction by controlling the rotations of the left and right side wheels. The steering device 40 can steer

a car by braking one side of each of the left and right braking units 23a and 23b depending on the left and right rotations of the steering handle 41. In more details, the driving device 20 is equipped with left and right braking units 23a and 23b for controlling the rotations of the left wheels 51a and 52a and the right wheels 51b and 52b. The steering device 40 can do a skid steering operation by braking one of the left braking unit 23a or right braking unit 23b depending on the left and right rotations of the steering handle 41. For example, the steering device 40 basically operates as a pulling cable(not shown) wound or unwound for driving the left and right braking units 23a and 23b is connected between the steering handle 41 and the braking units 23a and 23b, so when the steering handle 41 is rotated in the left direction, the pulling cable connected with the left braking unit 23a drives the left braking unit 23a for thereby braking the wheels 51a, 52a, 53a and 54a of the left row, whereby the car turns in the left direction. The present invention is characterized in that a driver, who is used to a rotation of a steering handle, but is not used to a skid steering, can control the braking of the left and right braking units 23a and 23b by rotating the steering handle 41, so the driver can drive in the same method as a common car steering method. In addition, the control unit 70 generates a braking signal depending on a steering signal and transmits to the braking units 23a and 23b for thereby performing a skid steering operation.

<52> On the water surface, the steering device 40 is basically characterized in that a desired steering operation on the water surface can be performed by controlling the revolution of left and right underwater motors 61a and 61b depending on the left and right rotations of the steering handle 41.

<53> Here, the water surface running device 60 is basically configured to generate propulsion force for running on a water surface and includes left and right underwater motors 61a and 61b, screws 62a and 62b connected with the left and right underwater motors 61a and 61b, and a lifting and lowering unit 63 for lifting and lowering the left and right underwater motors 61a and 61b in the upward and downward directions. The water surface running device

60 operates only when the water surface running mode is selected. As shown in the drawing, there is provided a water surface running device formed of a underwater motor in which a motor is positioned underwater for generating a rotational propulsion force. The left and right underwater motors 61a and 61b are disposed in the left and right sides of the rear end of the car body 10. The screws 62a and 62b are connected with the rotation shaft of each of the left and right underwater motors 61a and 61b. The lifting and lowering unit 63 makes it possible to lift and lower the left and right underwater motors 61a and 61b in the upward and downward directions. When the ground running mode is selected, the underwater motors 61a and 61b are lifted, and when the water surface running mode is selected, the underwater motors 61a and 61b are lowered, so the underwater motors 61a and 61b remain underwater. As shown in the drawing, the lifting and lowering unit 63 has a lower end connected with the underwater motors 61a and 61b and includes a slide bar 631 supported by the car body 10 slidably in the upward and downward direction, and a straight motion unit 632 for moving the slide bar 631 in the upward and downward directions. A screw is disposed in the upper side of the slide bar 631. The straight motion unit 632 includes a rotor 632b having a female thread formed in the center and engaged to a male thread, and a stator 632a which surrounds an outer side of the rotor 632b and generates a rotational force with respect to the rotor 632b along with the rotor 632b.

<54> The control unit 70 is configured to control the operations of a car. As shown in the drawing, the control unit 70 controls the operations of the first and second driving devices 20 and 20' and the left and right underwater motors 61a and 61b, so the car can run on a ground or a water surface as the ground running mode and the water surface running mode are selectively selected by means of a running mode selection switch 74. When the ground running mode is selected, the control unit 70 lifts the underwater motors 61a and 61b in the upward direction, and when the water surface running mode is selected, the underwater motors 61a and 61b are lowered, so the underwater motors 61a and 61b remain underwater. In addition, the control unit 70

receives an acceleration signal depending on an operation of the acceleration pedal 72 of the driver, and adjusts the outputs of the first and second driving motors 21 and 21' of the first and second driving devices 20 and 20' and the outputs of the left and right underwater motors 61a and 61b, respectively. As described earlier, the control unit 70 drives a car only with the first driving motor 21 on the ground, and drives a car with the remaining driving motor, namely, the second driving motor 21' when the speed of the vehicle is lower than a set level as compared to the output torque of the first driving motor 21 as the driving load increases when the car runs on a tough road or a slope. Namely, the control unit 70 operates the first driving motor 21 depending on an acceleration signal of the acceleration pedal 72, and operates the second driving motor 21' only when the speed of the car is lower than a set level in response to an acceleration signal of the acceleration pedal 72 when the driving load increases. The control unit 70 receives a speed signal of a car from the wheel revolution detection sensor 71 and controls the cooperating operations of the first driving motor 21 and the second driving motor 21'.

<55>

【Industrial Applicability】

<56> The present invention can make it possible to minimize the consumption of charged power by controlling the operations of the driving motors depending on a change of the driving load so that an output needed for an optimized running of a car can be outputted depending on a change of the driving load.

<57> The above described electric car shown in the drawings is provided as one embodiment for implementing the present invention.

<58> As the present invention may be embodied in several forms without departing from the spirit or essential characteristics thereof, it should also be understood that the above-described examples are not limited by any of the details of the foregoing description, unless otherwise specified, but rather should be construed broadly within its spirit and scope as defined in

the appended claims, and therefore all changes and modifications that fall within the meets and bounds of the claims, or equivalences of such meets and bounds are therefore intended to be embraced by the appended claims.

<59>

【CLAIMS】**【Claim 1】**

<61> In an electric car which includes wheels disposed in left and right sides of a car body for running operations, and a driving force device for generating a driving force for driving wheels using electric power, an electric car, comprising:

said wheels provided in the front and rear sides of the car body in at least two rows in each side;

said driving device which includes a first driving motor and a second driving motor, and a first driving force transfer unit and a second driving force transfer unit for transferring the outputs of the first and second driving motors to the wheels of a front row and the wheels of a rear row, respectively; and

<62> a control unit which is configured to drive either the first driving motor or the second driving motor and is configured to drive both the first driving motor and the second driving motor when the speed of a car is lower than a set level as compared to an output torque of the currently driven motor between the first and second driving motors.

<63>

【Claim 2】

<64> The car of claim 1, wherein said car body is configured to run on a water surface, and includes a water surface running device for running on a water surface, and said water surface running device includes a left and right underwater motors provided in the left and right sides of a rear end of the car body, a screw connected with a rotation shaft of each of the left and right underwater motors, and a lifting and lowering means for lifting and lowering the underwater motors in the upward and downward directions, and said lifting and lowering means is configured to lift the underwater motors in the upward direction when a ground running mode is selected, and to lower the underwater motors when the water surface running mode is selected, so the underwater motors remain underwater.

<65>

【Claim 3】

<66> The car of claim 2, wherein said lifting and lowering means includes a slide bar having a lower end connected with the underwater motor and being supported by the car body to slide in the upward and downward directions, and a straight motion unit for moving the slide bar in the upward and downward directions.

<67>

【Claim 4】

<68> The car of claim 3, wherein a screw is provided in an upper side of the slide bar, and said straight motion unit includes a rotor having a female thread formed in the center and engaged to a male thread, and a stator which surrounds an outer side of the rotor and generates a rotational force with respect to the rotor along with the rotor.

<69>

<70>

<71>

<72>

<73>

<74>

【DRAWINGS】

【Figure 1】

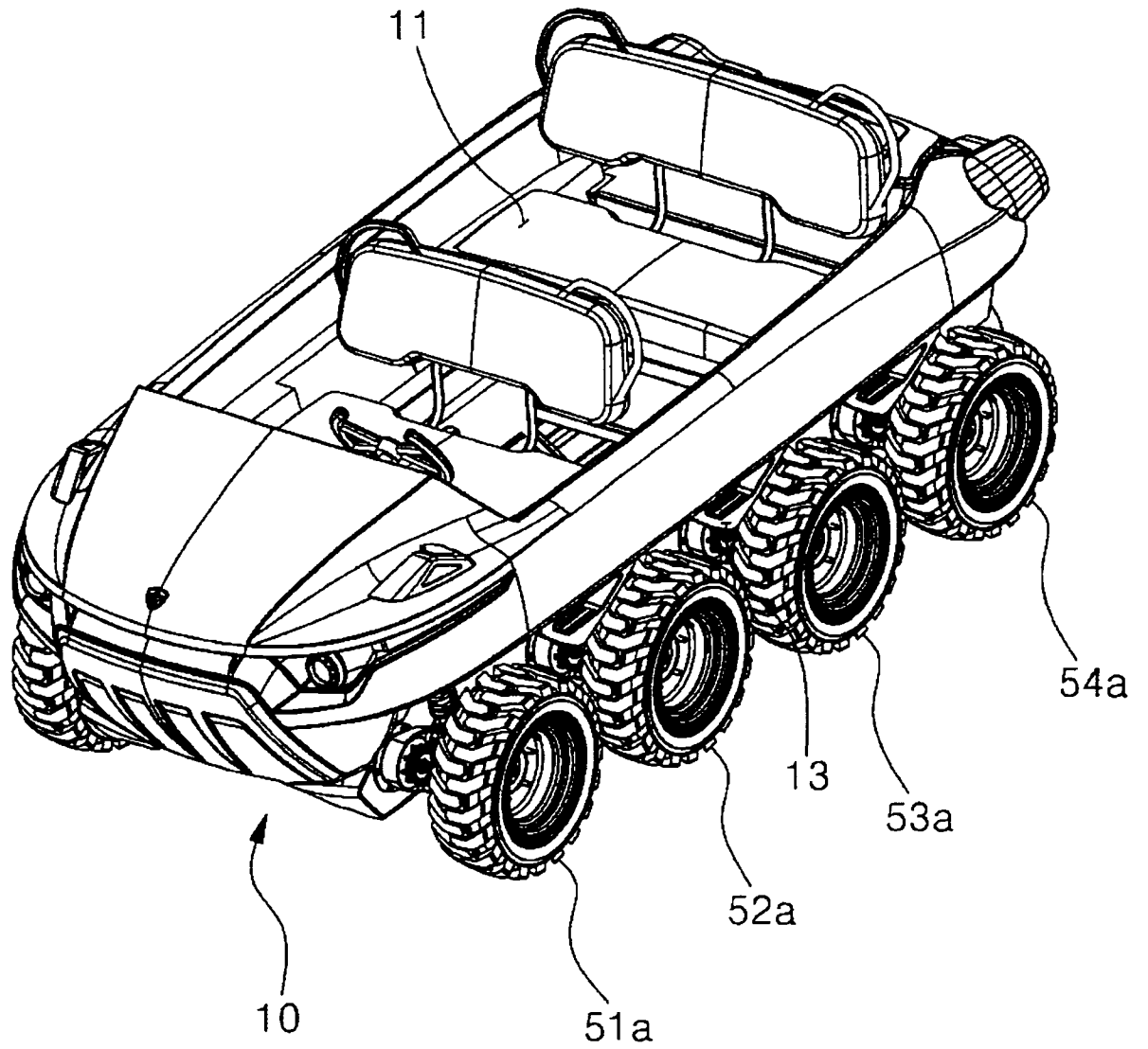

【Figure 2】

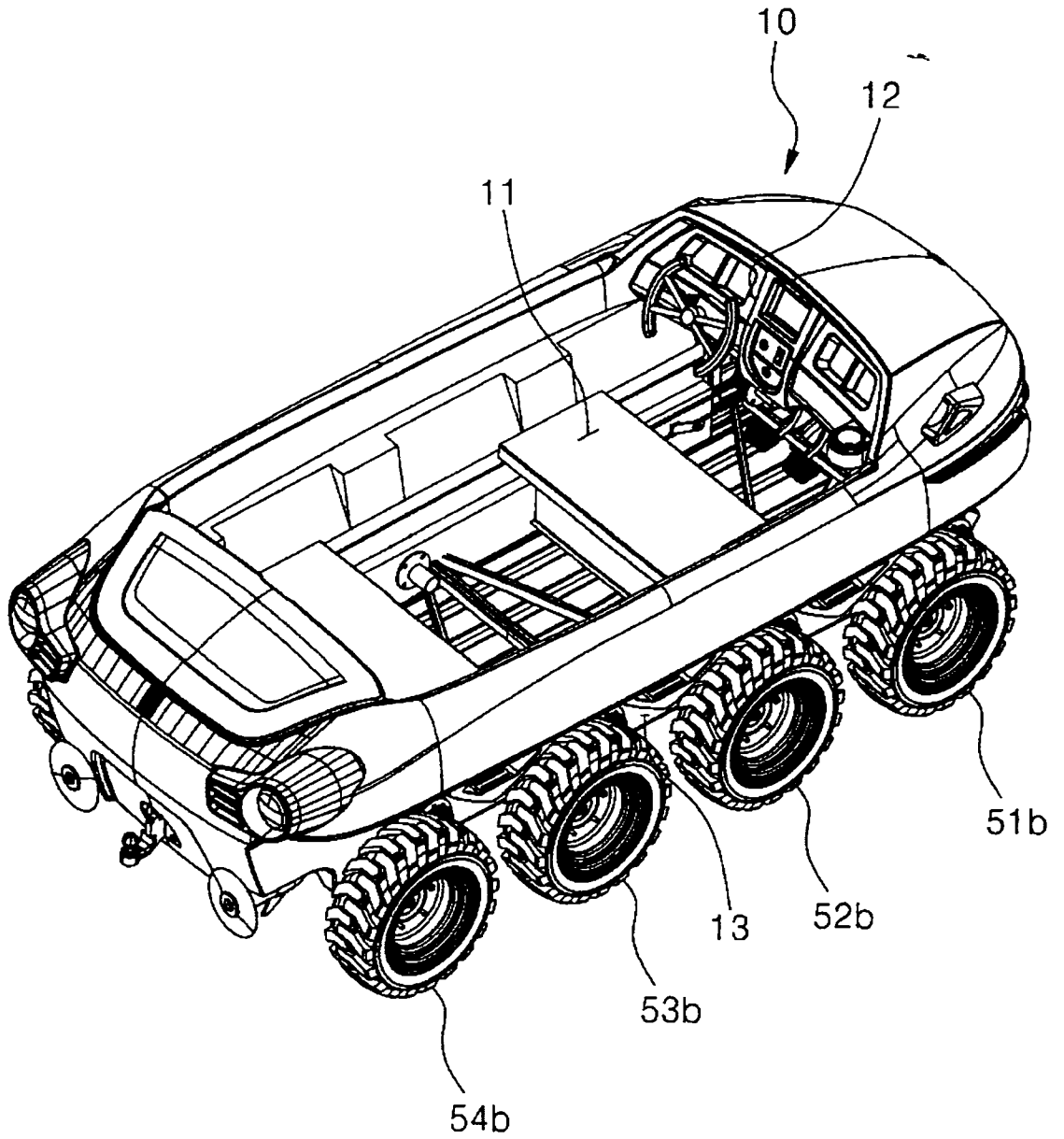

【Figure 3】

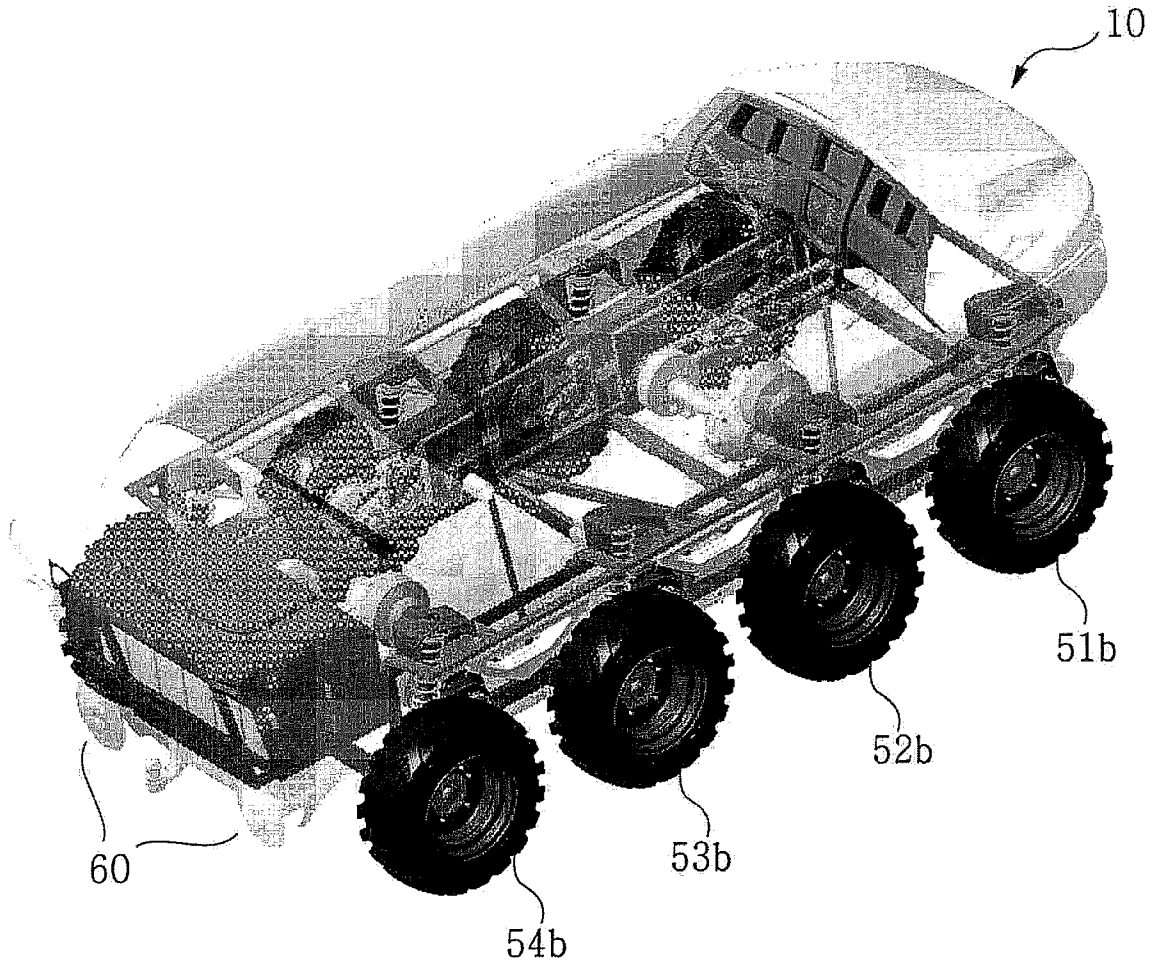

【Figure 4】

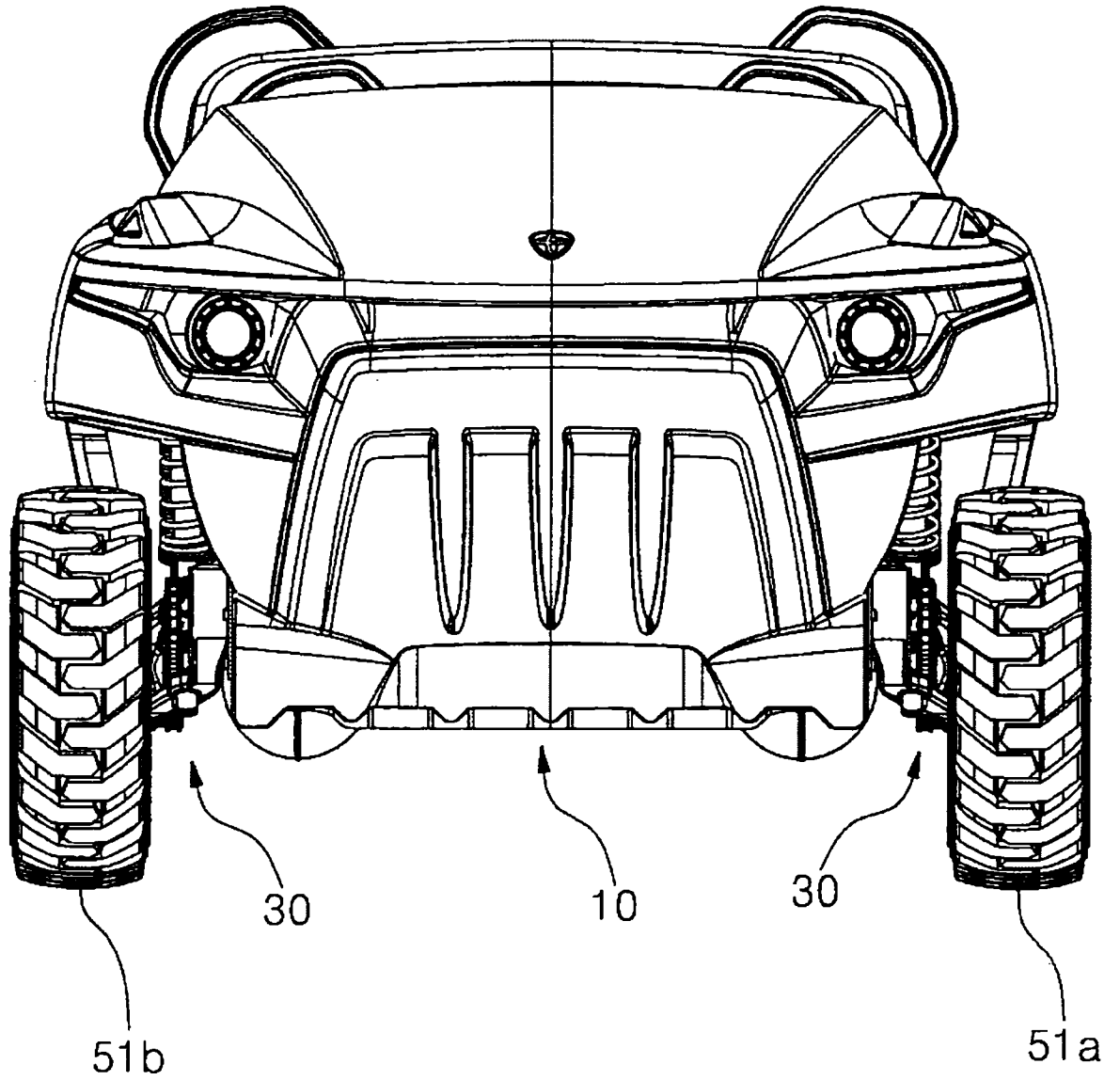

【Figure 5】

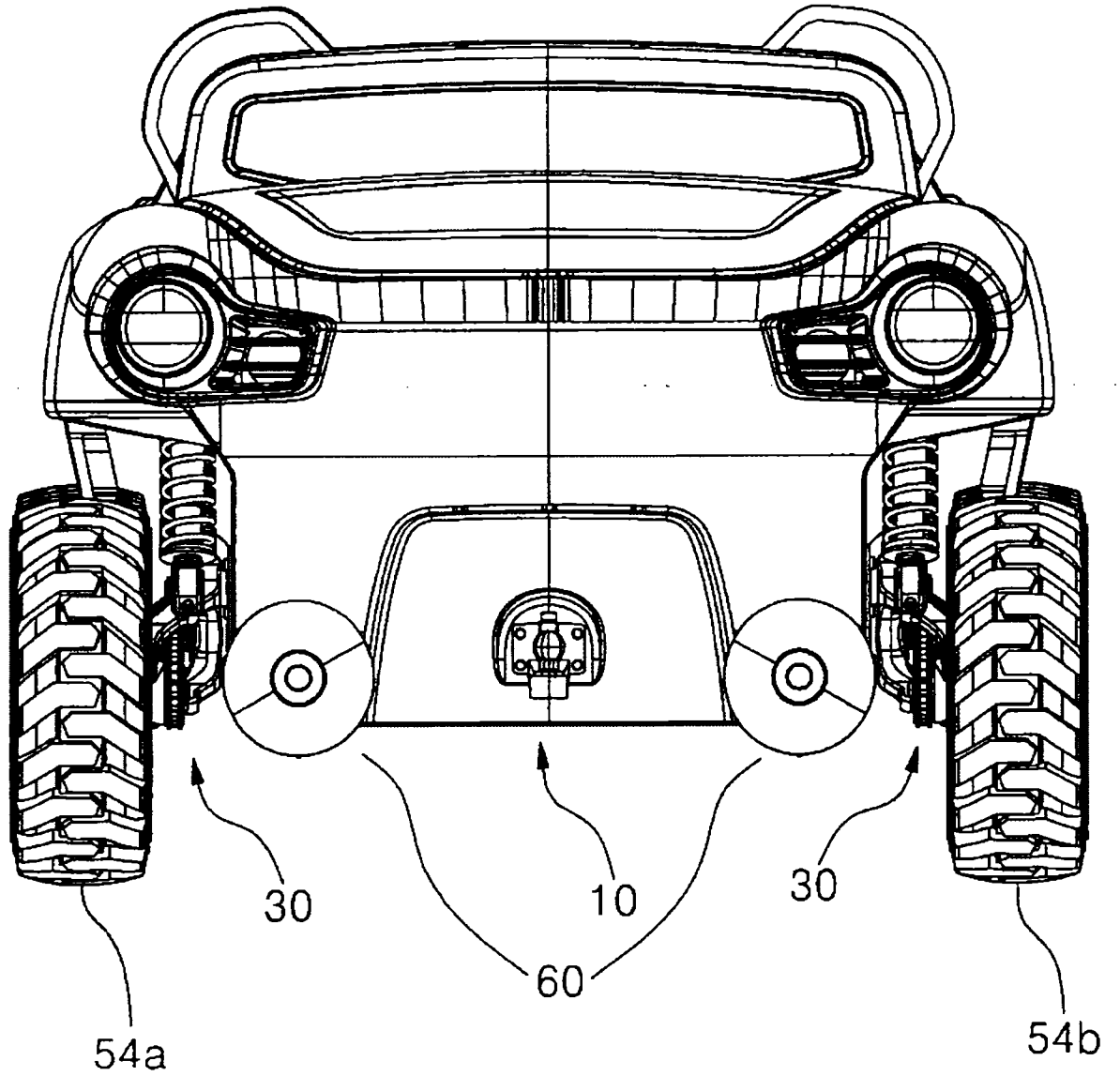

【Figure 6】

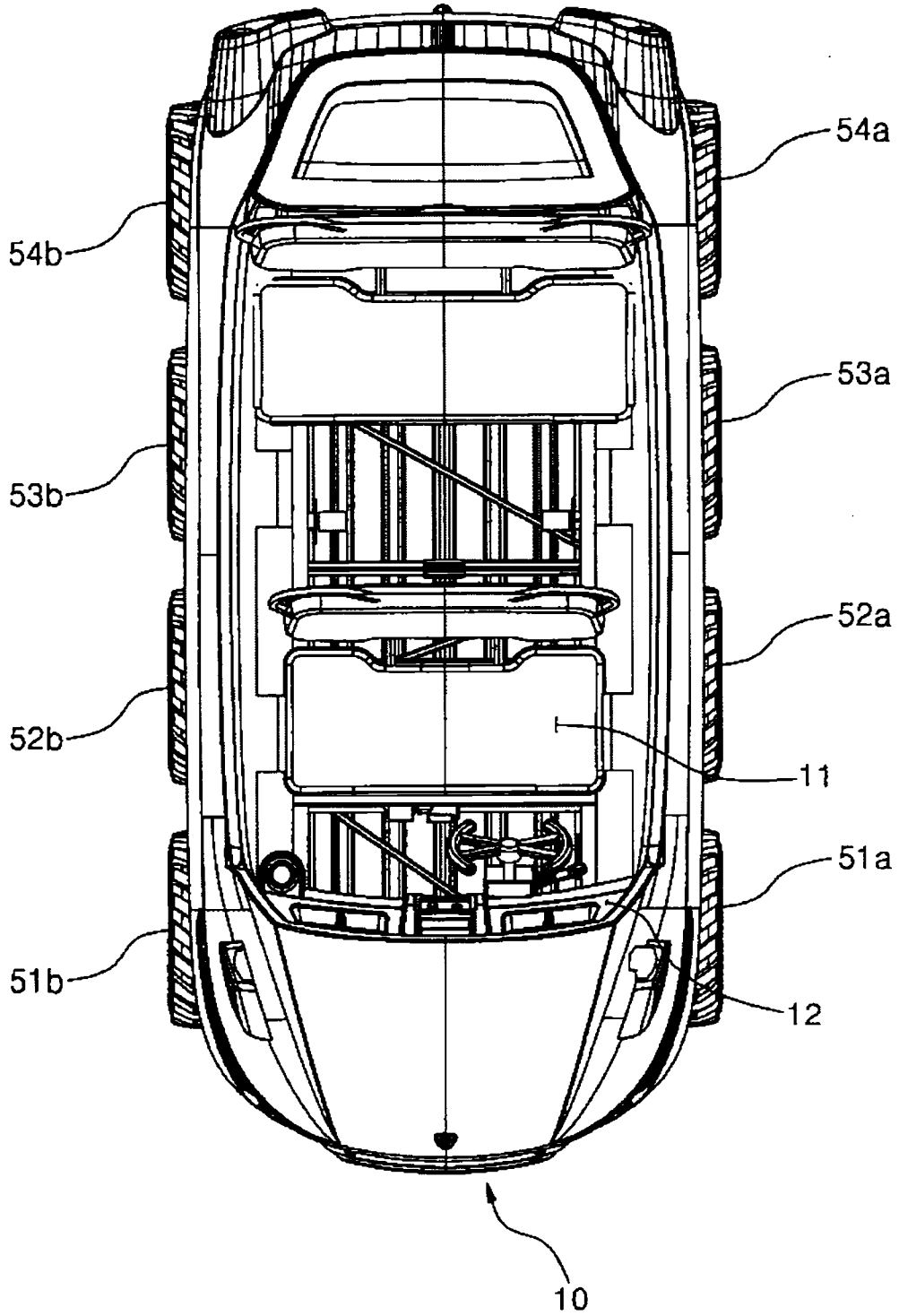

【Figure 7】

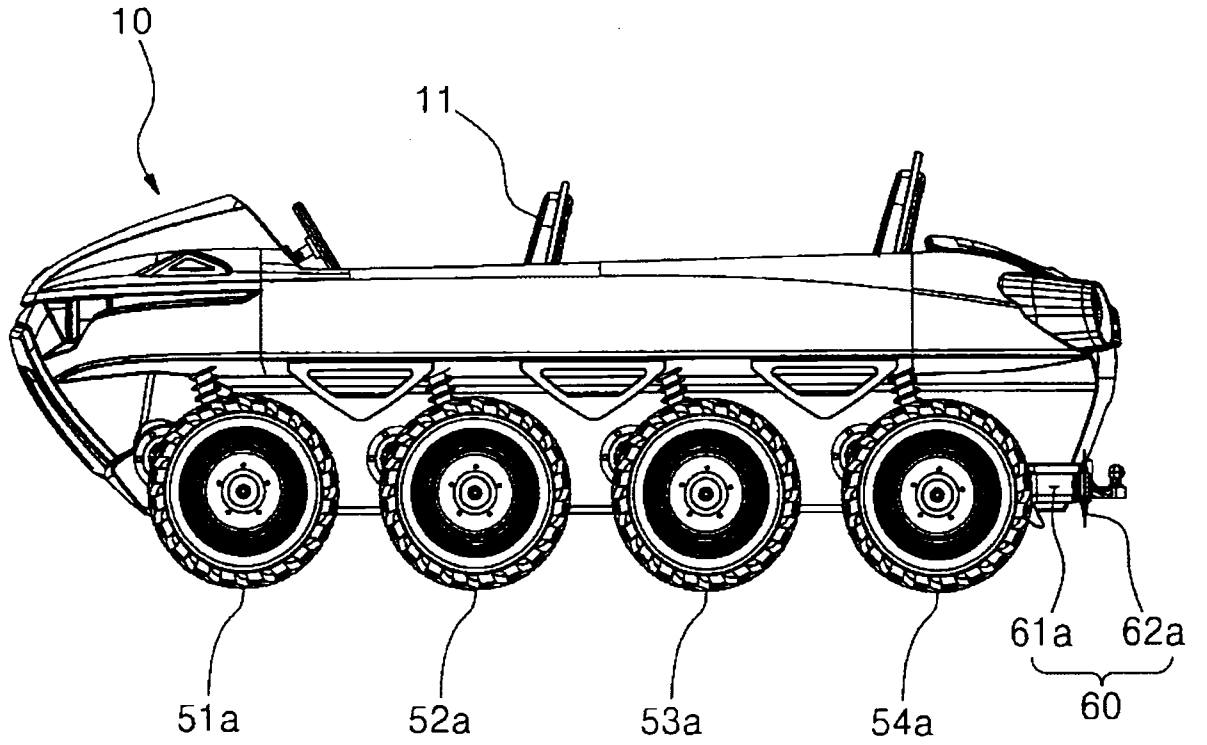

【Figure 8】

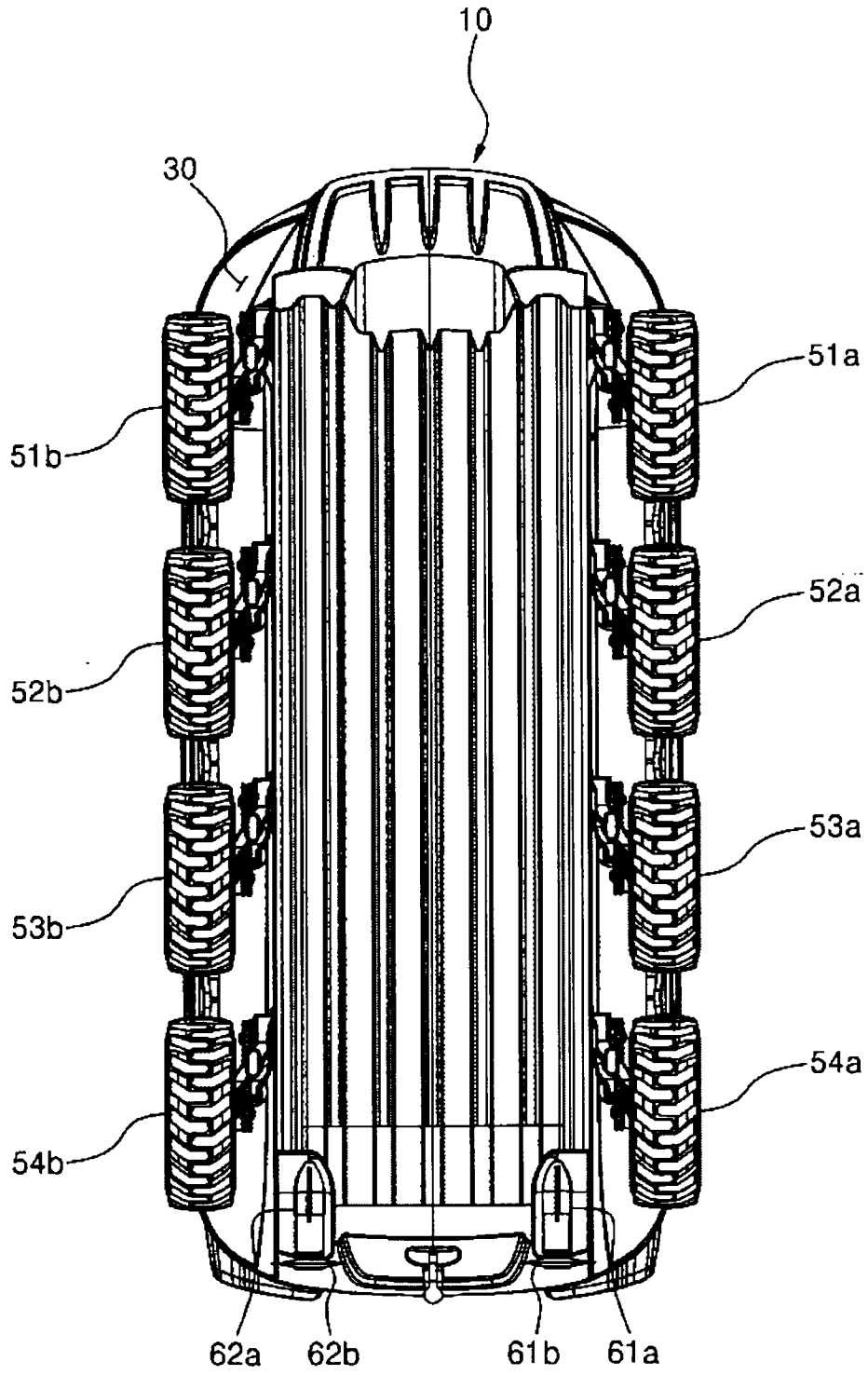

【Figure 9】

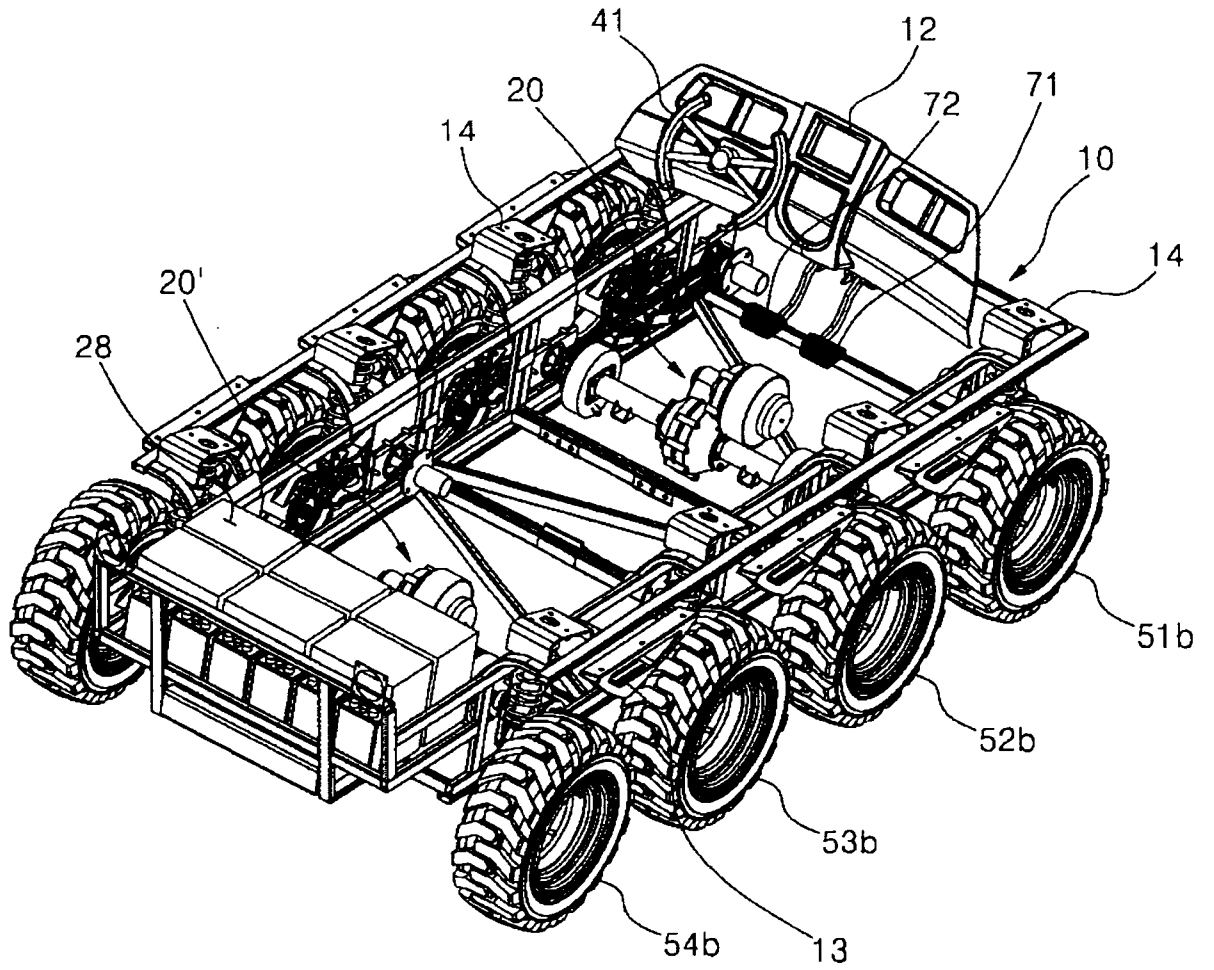

【Figure 10】

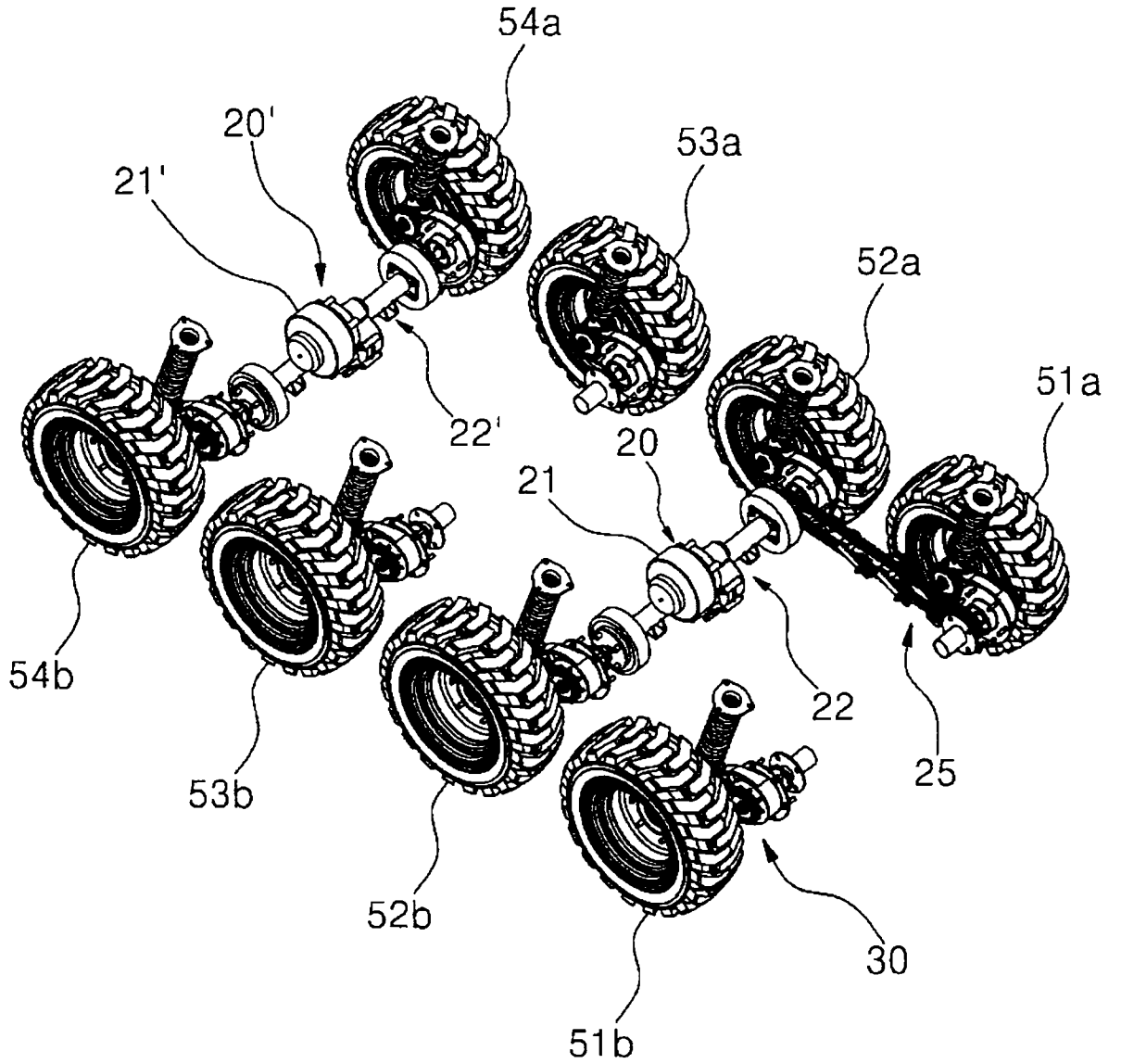

【Figure 11】

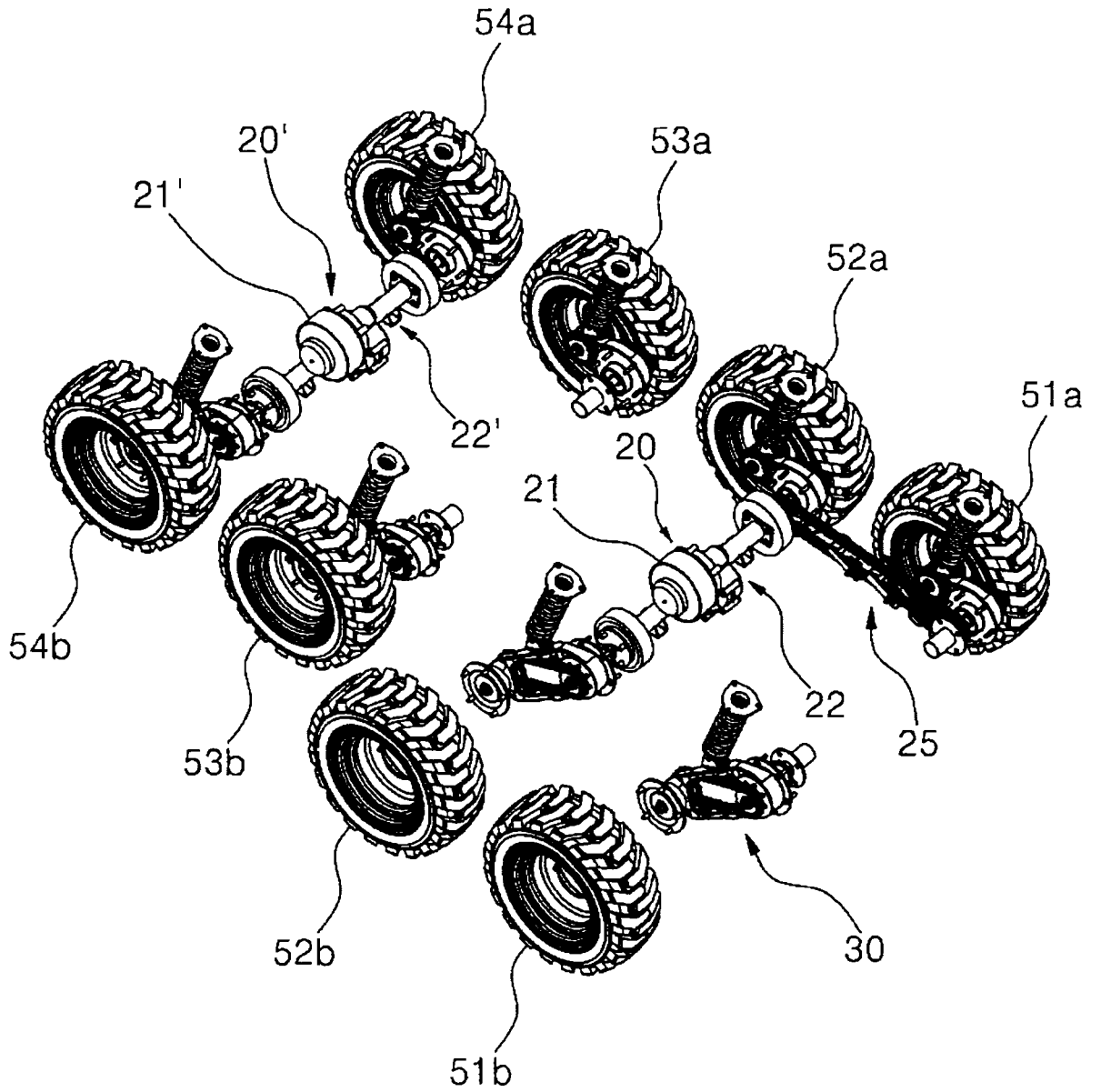

【Figure 12】

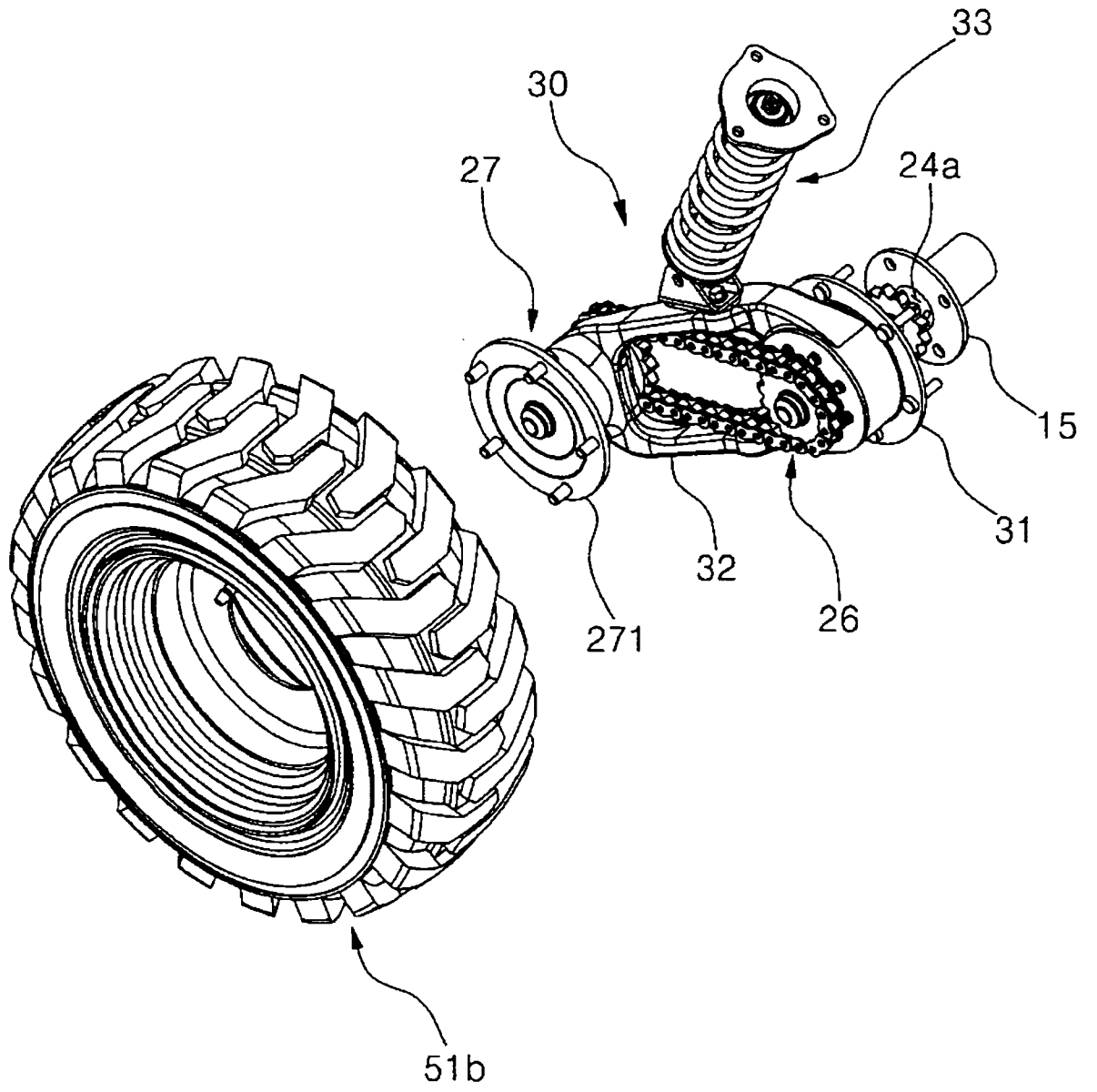

[Figure 13]

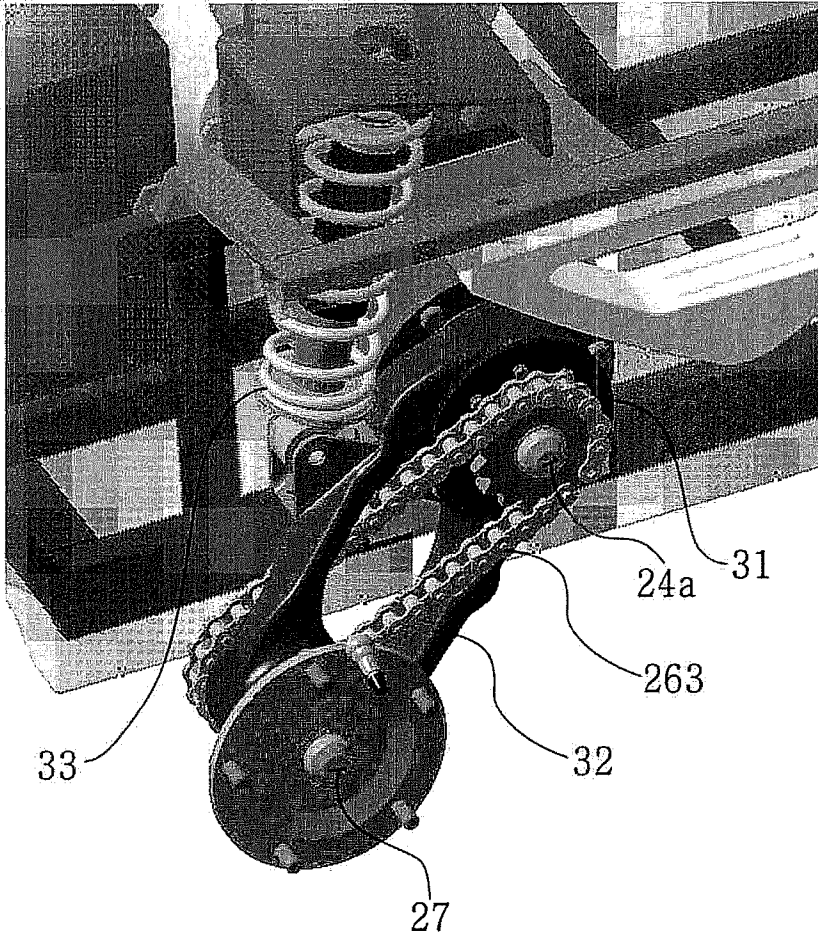

[Figure 14]

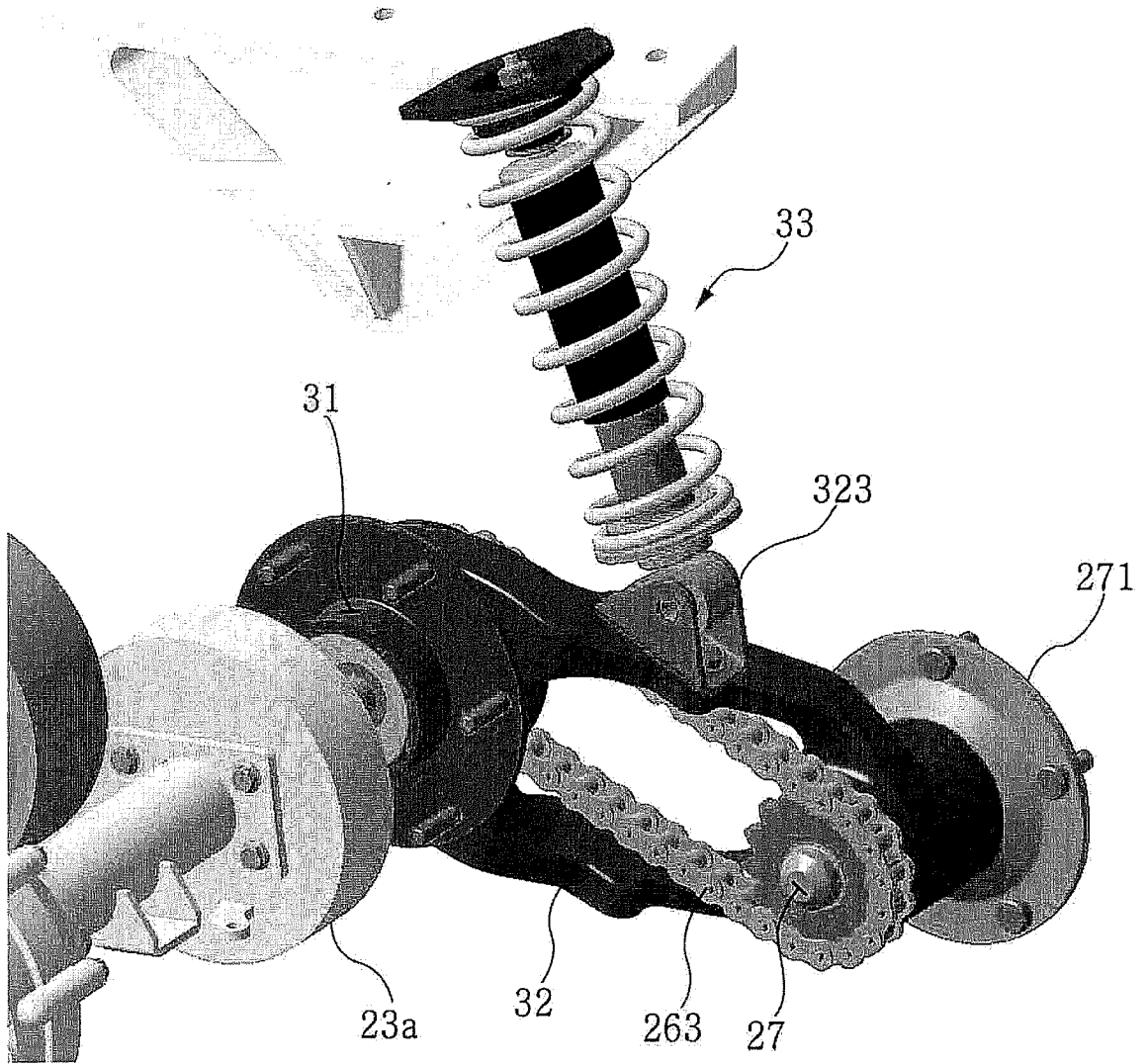

【Figure 15】

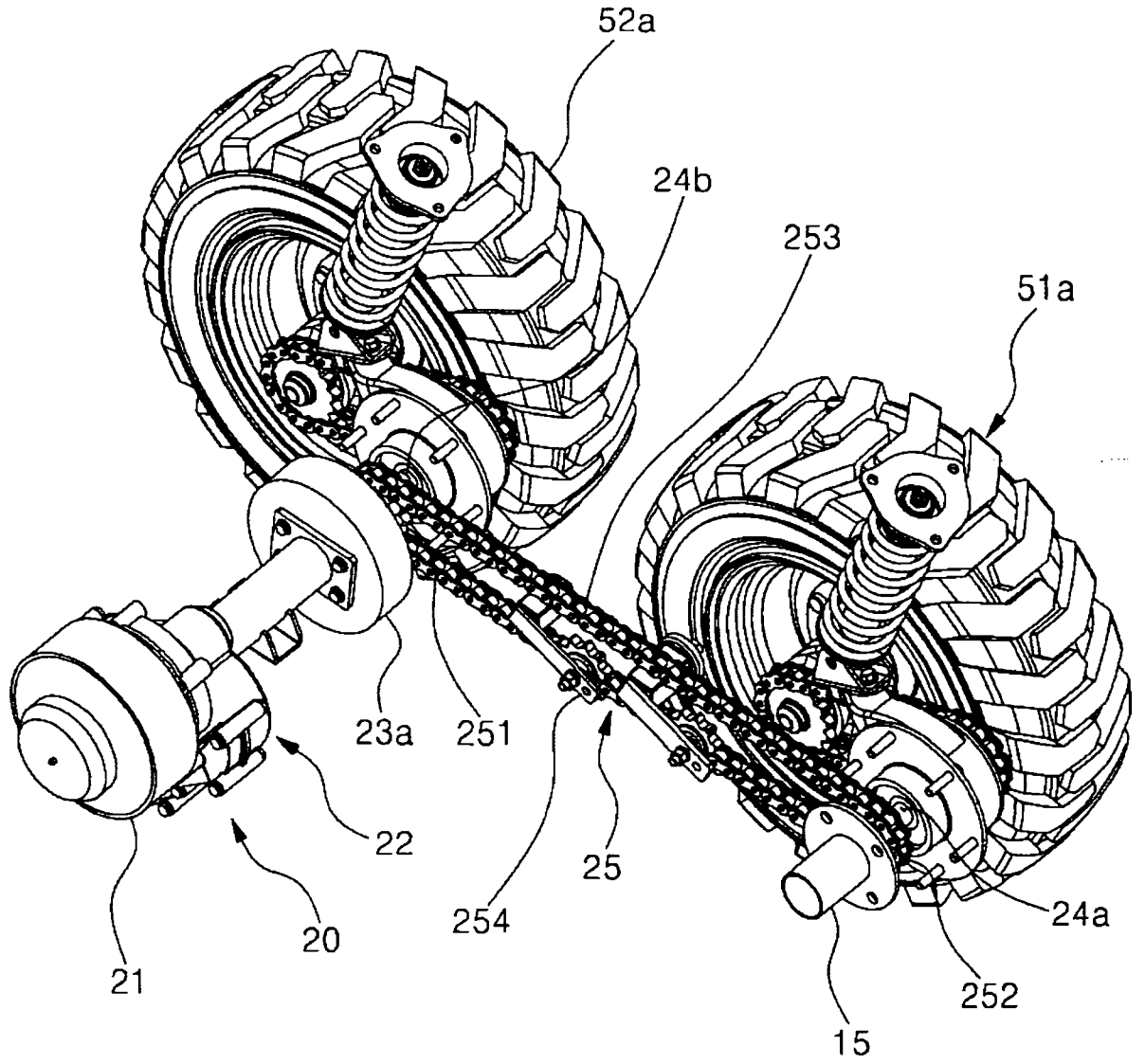

[Figure 16]

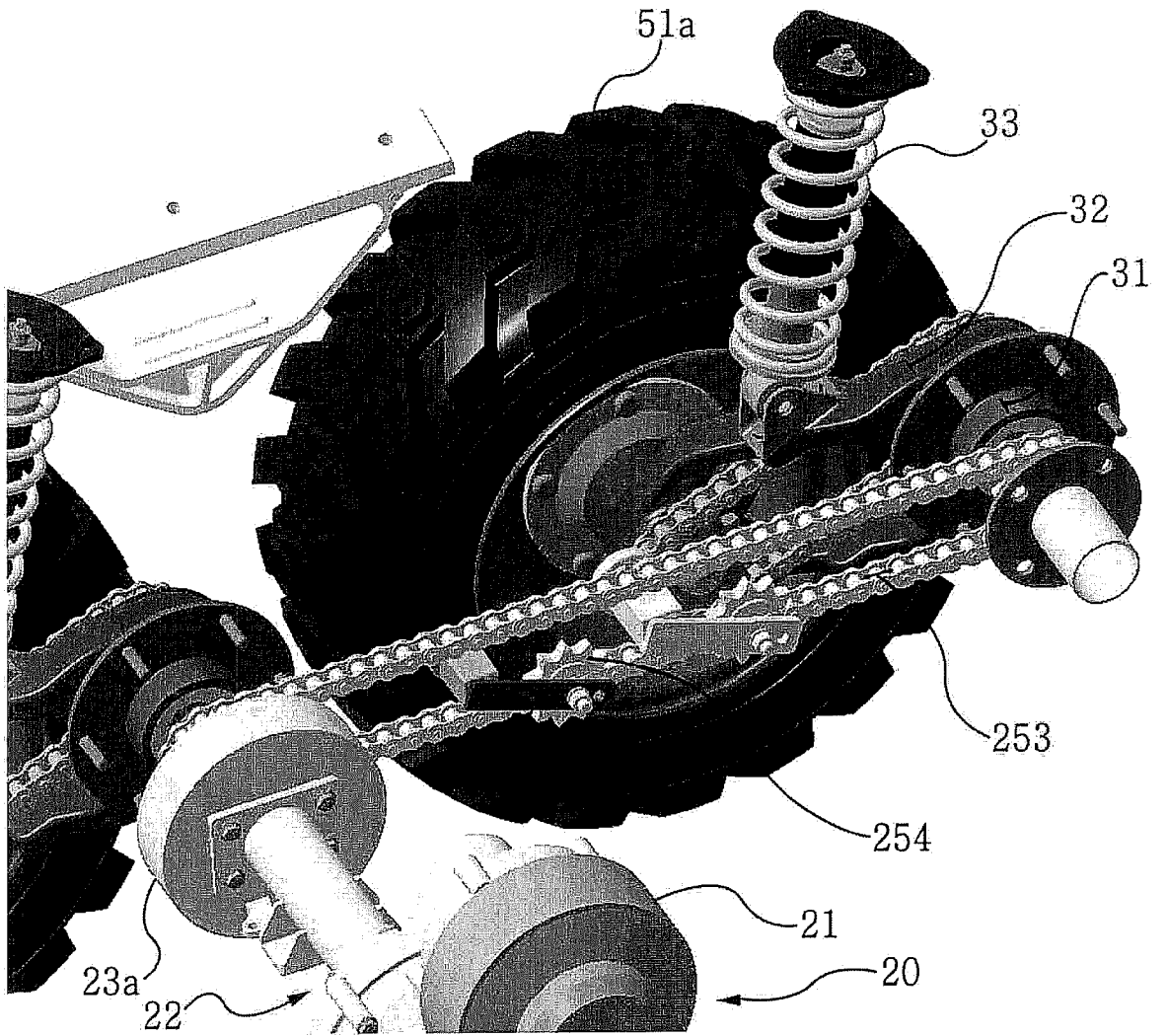

【Figure 17】

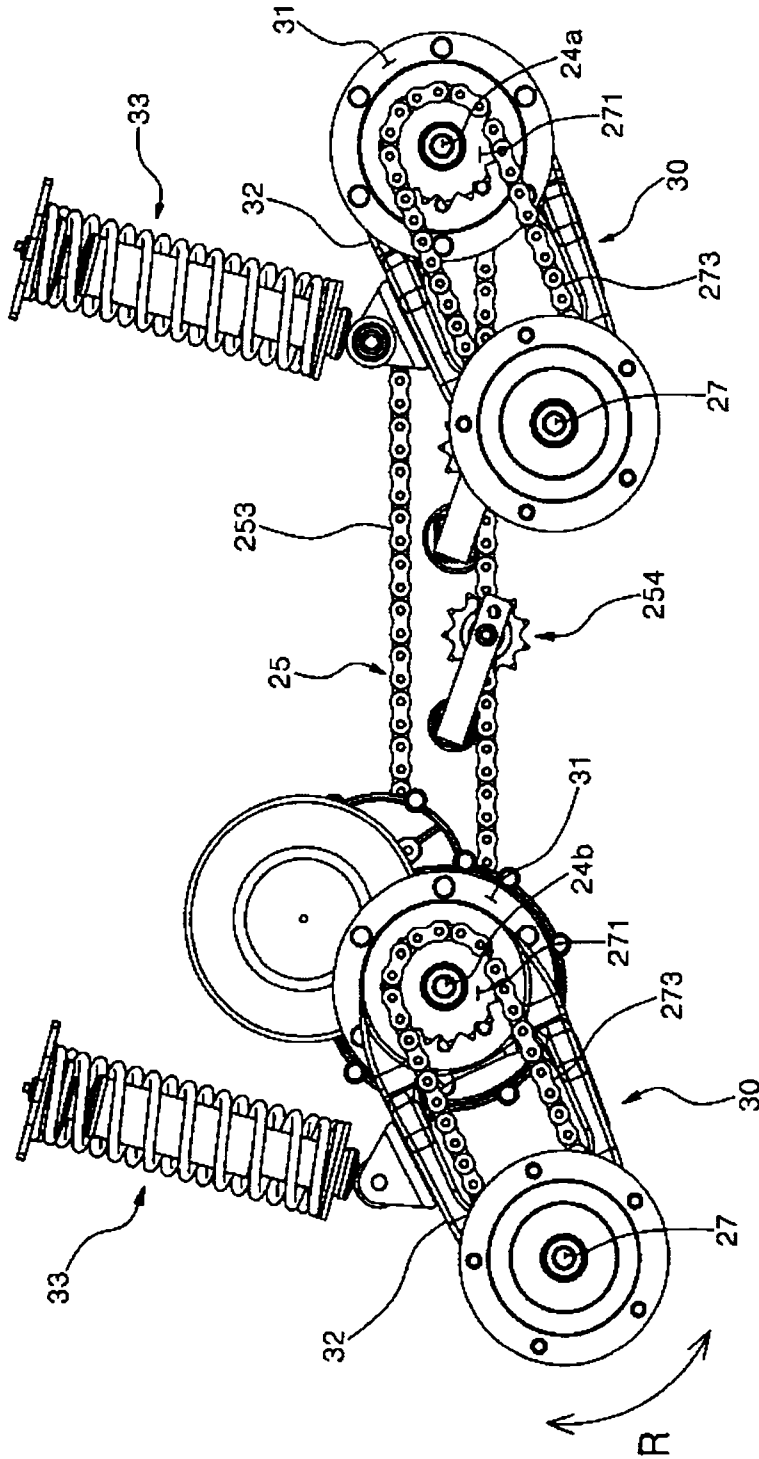

【Figure 18】

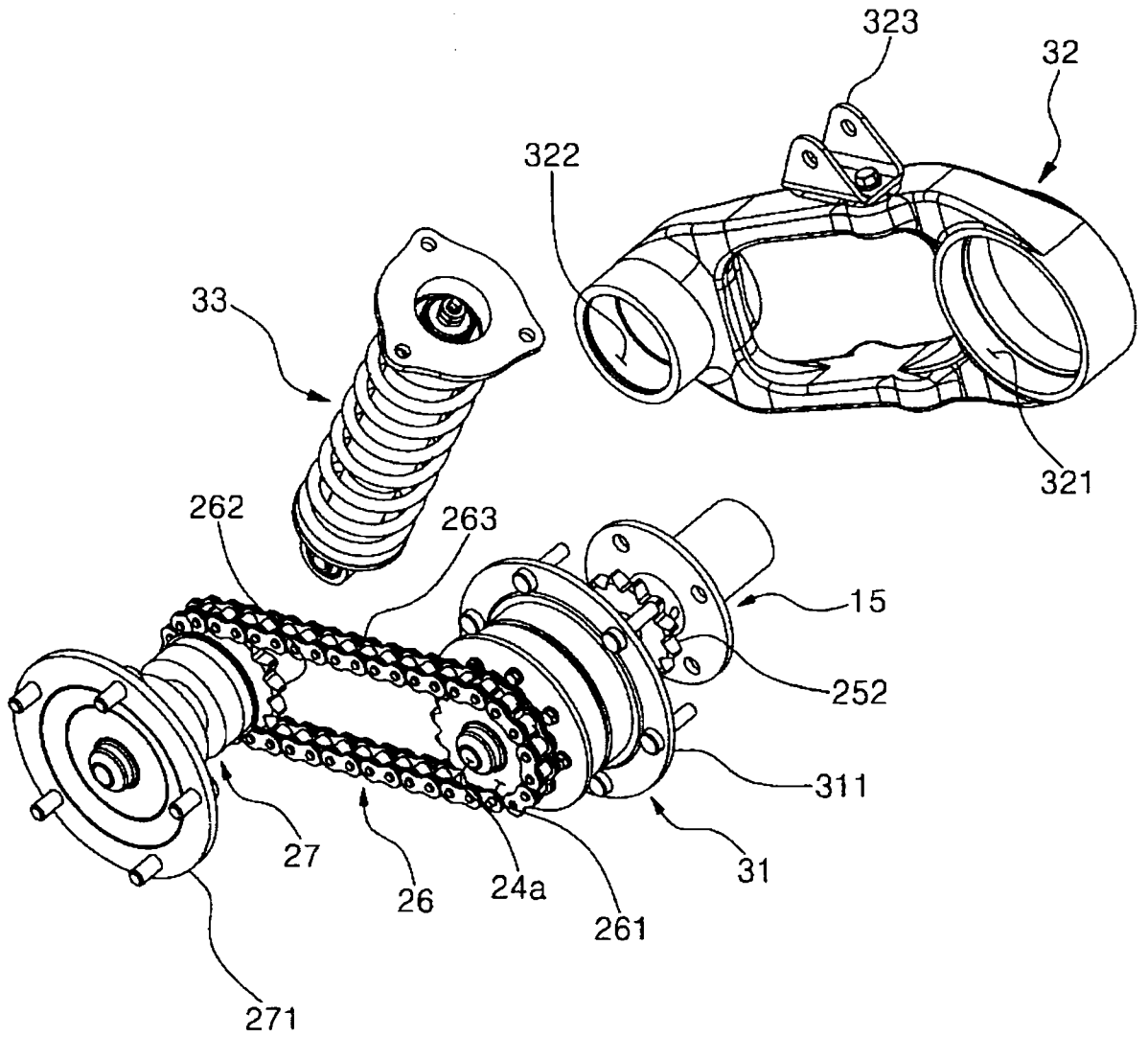

【Figure 20】

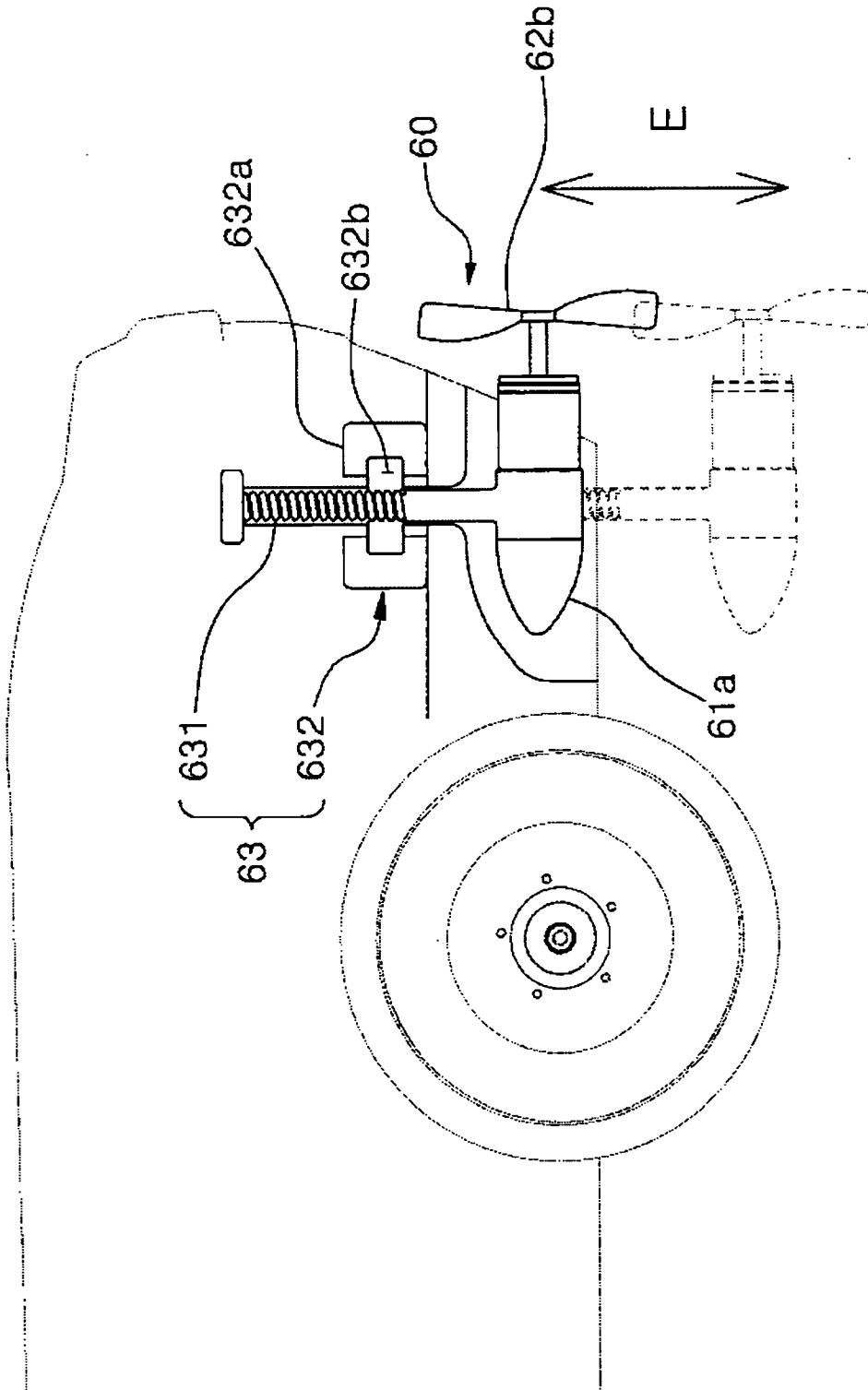

【Figure 21】

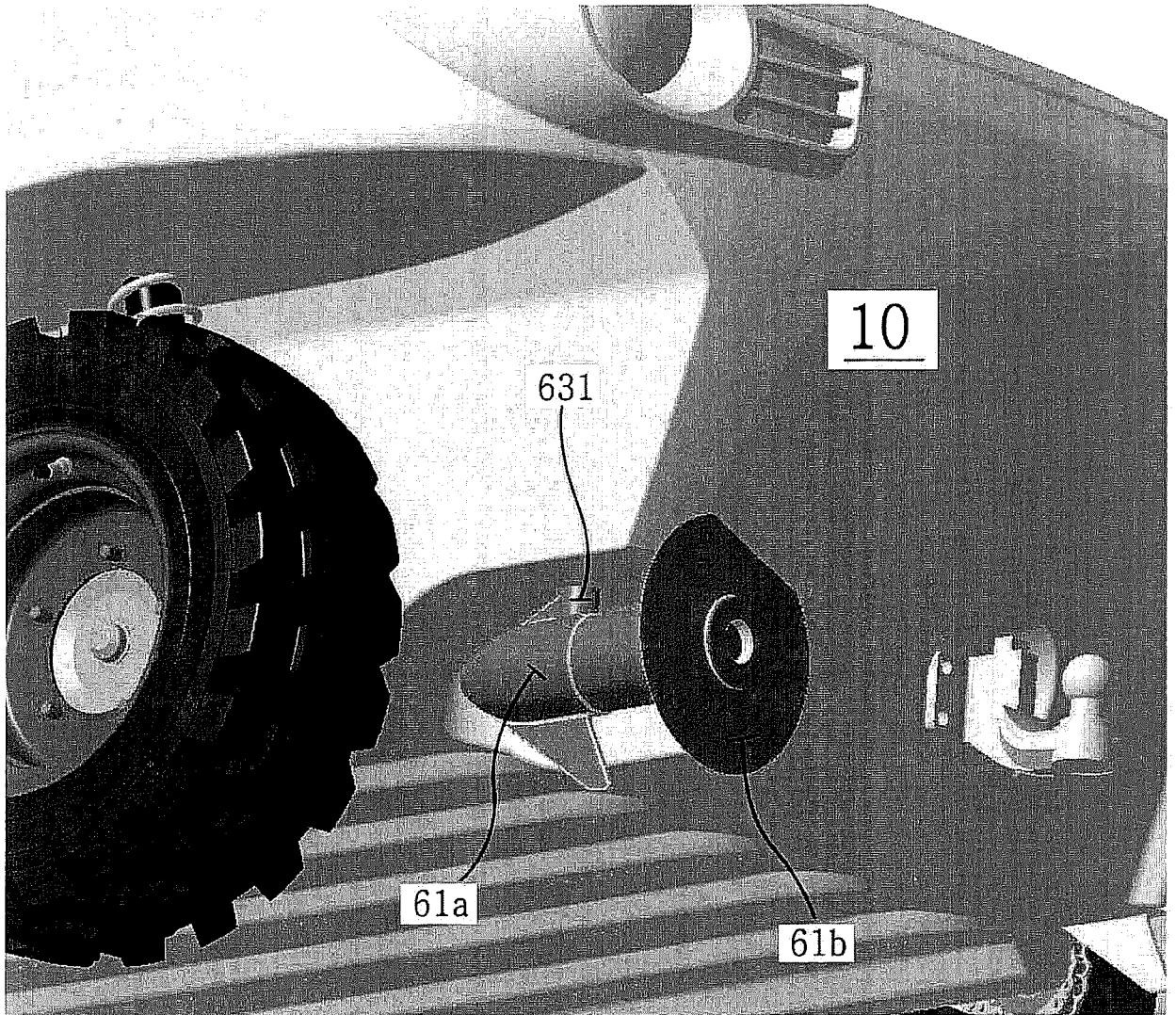

A. CLASSIFICATION OF SUBJECT MATTER***B60L 11/18(2006.01)i***

According to International Patent Classification (IPC) or to both national classification and IPC

B. FIELDS SEARCHED

Minimum documentation searched (classification system followed by classification symbols)

IPC8 B60L

Documentation searched other than minimum documentation to the extent that such documents are included in the fields searched

Korean Utility models and applications for Utility models since 1975

Japanese Utility models and applications for Utility models since 1975

Electronic data base consulted during the international search (name of data base and, where practicable, search terms used)

eKOMPASS(KIPO internal) and keywords "electric, car, wheel, driving, force, device, generate, motor, water, direction, and similar terms"

C. DOCUMENTS CONSIDERED TO BE RELEVANT

Category*	Citation of document, with indication, where appropriate, of the relevant passages	Relevant to claim No.
Y	JP 06-062508 A (NISSAN MOTOR CO., LTD.) 3 March 1994 See abstract, Figures 1-4 and claims 1-3	1-4
Y	KR 10-2004-0101835 A (HYUNDAI MOTOR COMPANY) 3 December 2004 See abstract, Figures 1-3 and claims 1-12	1-4
Y	KR 10-1999-0069121 A (KIM, HO KYUN) 6 September 1999 See abstract, Figures 1-3 and claims 1-4	1-4
A	KR 20-1996-0016768 U (SEO, SEUNG YONG) 17 June 1996 See abstract, Figures 1-3 and claims 1-2	1-4

 Further documents are listed in the continuation of Box C. See patent family annex.

* Special categories of cited documents:

"A" document defining the general state of the art which is not considered to be of particular relevance

"E" earlier application or patent but published on or after the international filing date

"L" document which may throw doubts on priority claim(s) or which is cited to establish the publication date of citation or other special reason (as specified)

"O" document referring to an oral disclosure, use, exhibition or other means

"P" document published prior to the international filing date but later than the priority date claimed

"T" later document published after the international filing date or priority date and not in conflict with the application but cited to understand the principle or theory underlying the invention

"X" document of particular relevance; the claimed invention cannot be considered novel or cannot be considered to involve an inventive step when the document is taken alone

"Y" document of particular relevance; the claimed invention cannot be considered to involve an inventive step when the document is combined with one or more other such documents, such combination being obvious to a person skilled in the art

"&" document member of the same patent family

Date of the actual completion of the international search

06 AUGUST 2009 (06.08.2009)

Date of mailing of the international search report

06 AUGUST 2009 (06.08.2009)

Name and mailing address of the ISA/KR

Korean Intellectual Property Office
Government Complex-Daejeon, 139 Seonsa-ro, Seo-gu, Daejeon 302-701, Republic of Korea

Facsimile No. 82-42-472-7140

Authorized officer

KIM, Jun Hak

Telephone No. 82-42-481-5785



INTERNATIONAL SEARCH REPORT

Information on patent family members

International application No.

PCT/KR2008/007550

Patent document cited in search report	Publication date	Patent family member(s)	Publication date
JP 06-062508 A	04.03.1994	US 05374877 A	20.12.1994
KR 10-2004-0101835 A	03.12.2004	None	
KR 10-1999-0069121 A	06.09.1999	None	
KR 20-1996-0016768 U	17.06.1996	None	