



(12) **EUROPEAN PATENT APPLICATION**

(43) Date of publication:  
**29.11.2006 Bulletin 2006/48**

(51) Int Cl.:  
**H01Q 9/04<sup>(2006.01)</sup> H01Q 1/52<sup>(2006.01)</sup>**

(21) Application number: **06112014.3**

(22) Date of filing: **30.03.2006**

(84) Designated Contracting States:  
**AT BE BG CH CY CZ DE DK EE ES FI FR GB GR  
HU IE IS IT LI LT LU LV MC NL PL PT RO SE SI  
SK TR**  
Designated Extension States:  
**AL BA HR MK YU**

(72) Inventors:  
• **Ohtaki, Yukio,**  
**c/o Alps Electric Co., Ltd.**  
**Ota-ku,**  
**Tokyo (JP)**  
• **Higasa, Masahiko,**  
**c/o Alps Electric Co., Ltd.**  
**Ota-ku,**  
**Tokyo (JP)**

(30) Priority: **23.05.2005 JP 2005149807**

(71) Applicant: **ALPS ELECTRIC CO., LTD.**  
**Ota-ku**  
**Tokyo 145 (JP)**

(74) Representative: **Kensett, John Hinton**  
**Saunders & Dolleymore,**  
**9 Rickmansworth Road**  
**Watford,**  
**Hertfordshire WD18 0JU (GB)**

(54) **Planar antenna device**

(57) A planar antenna device includes a radiation conductor layer and a plurality of capacitor electrodes which are provided on an inner surface of a window glass of a vehicle, a ground conductor layer which is provided on one surface of a circuit board so as to face the radiation conductor layer with an air layer interposed therebetween, a bracket, formed of a metal plate, which has a

brim closely facing the capacitor electrodes and is mounted on the window glass with the circuit board housed and held therein, and a dielectric layer which is interposed between the capacitor electrodes and the brim. The capacitor electrodes extend outward from the edges of the radiation conductor layer and are capacitively coupled with the brim, thereby reducing the size of the planar antenna device.

**FIG. 1**

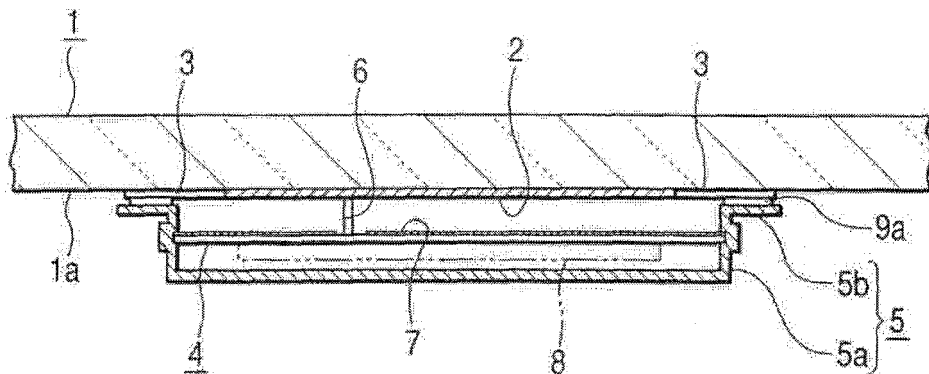

**Description**

## BACKGROUND OF THE INVENTION

## 1. Field of the Invention

**[0001]** The present invention relates to a small planar antenna device having a patch antenna structure, in particular, a planar antenna suitable for a vehicle.

## 2. Description of the Related Art

**[0002]** In recent years, an on-vehicle small antenna, such as an antenna for an ETC (electronic toll collection system) or an antenna for a GPS (global positioning system), is increasingly demanded. As such an antenna, there is widely used a planar antenna device of a patch antenna structure that easily receives circularly polarized waves used in an ETC or a GPS.

**[0003]** In general, a known on-vehicle planar antenna device according to the related art has a dielectric substrate which has a radiation conductor layer provided on its upper surface, a circuit board which has a ground conductor layer provided on its upper surface on which the dielectric substrate is mounted and an electronic circuit unit provided on its lower surface, and a shield case, formed of a metal plate, which is mounted on the circuit board so as to cover the electronic circuit unit. The radiation conductor layer and the electronic circuit unit are electrically connected to each other by a feed pin passing through the dielectric substrate and the circuit board (for example, see JP-A-2004-88444 (pages 2 and 3, and FIG. 5)). In such a planar antenna device according to the related art, the electronic circuit unit is electrically connected to an external circuit through a coaxial cable or the like. And then, the radiation conductor layer is excited by power supplied through the feed pin, and thus circularly polarized waves or linearly polarized waves of a predetermined frequency band are transmitted or received. Further, the electronic circuit unit is covered with the shield case so as to be electromagnetically shielded. Therefore, noise due to unexpected external electric waves rarely has influence on the electronic circuit unit. If a low-noise amplifying circuit is provided in the electronic circuit unit, the planar antenna device is suited to receive weak electric waves in the GPS or the like. In addition, the dielectric substrate is interposed between the radiation conductor layer and the ground conductor layer, and thus it is easy to reduce the size of the antenna device by a wavelength shortening effect of the dielectric substrate.

**[0004]** However, in the above-described planar antenna device according to the related art, in order to promote the reduction in size, a relatively expensive dielectric substrate is provided between the radiation conductor layer and the ground conductor layer. Accordingly, it is difficult to manufacture the antenna device at low cost due to high component costs. In addition, when such a planar

antenna device is installed in a window glass of a vehicle, the field of vision may be obstructed. Therefore, the reduction in size is further demanded.

## 5 SUMMARY OF THE INVENTION

**[0005]** The invention has been finalized in view of the drawbacks inherent in the related art, and it is an object of the invention to provide a planar antenna device which can be manufactured at low cost and can be easily reduced in size.

**[0006]** In order to achieve the above-described objects, according to an aspect of the invention, a planar antenna device includes a radiation conductor layer which is provided on a glass surface of an installed apparatus, capacitor electrodes which are provided on the glass surface so as to extend outward from the edges of the radiation conductor layer, a ground conductor layer which faces the radiation conductor layer with an air layer interposed therebetween, a bracket, formed of a metal plate, which has a flat capacitor plate closely facing the capacitor electrodes and is mounted on the glass surface with a circuit board housed and held therein, and a dielectric layer which is interposed at least between the capacitor electrodes and the flat capacitor plate. The ground conductor layer and the bracket are electrically connected to each other, and the capacitor electrodes and the flat capacitor plate are capacitively coupled with each other.

**[0007]** In the planar antenna device having the above-described configuration, the radiation conductor layer is provided on the surface (glass surface) of a window glass of a vehicle or the like, a wavelength shortening effect of a glass plate serving as a dielectric can be used. For this reason, since an expensive dielectric substrate can be removed, the component cost can be reduced, and thus the reduction in size can be realized. Besides, by capacitively coupling the capacitor electrodes extending outward from the edges of the radiation conductor layer with the flat capacitor plate of the bracket serving as a ground, a resonance frequency of the radiation conductor layer can be reduced, which is also of advantage to the reduction in size. Therefore, the size of the planar antenna device is easily reduced, and the field of vision is rarely obstructed even if the planar antenna device is installed on the window glass of the vehicle. Moreover, the capacitor electrodes and the radiation conductor layer can be collectively formed on the glass surface. Further, since the dielectric layer interposed between the capacitor electrodes and the flat capacitor plate may be significantly thinned, the cost can be prevented from being increased.

**[0008]** In the planar antenna device according to the invention, the bracket may have a brim which is adhered to the glass surface, and a part of the brim may form the flat capacitor plate. Accordingly, the mounting work of the bracket is easily performed by causing the brim to closely face the glass surface. Further, by causing the

part of the brim to face the capacitor electrodes with the dielectric layer interposed therebetween, an exclusive-use flat capacitor plate does not need to be provided.

**[0009]** In the planar antenna device according to the invention, the dielectric layer of a capacitively coupled portion may be a base layer of a both-sided adhesive sheet, the both-sided adhesive sheet may be interposed between the glass surface and the brim so as to adhere and fix the brim to the glass surface by adhesive layers provided at both surfaces of the base layer. Accordingly, the both-sided adhesive sheet for mounting the bracket on the glass surface also functions as a dielectric layer. Therefore, the number of components can be reduced and assembling workability can be improved. As a result, the cost can be reduced.

**[0010]** Further, in the planar antenna device according to the invention, a plurality of dummy electrodes may be distributed in the periphery of the radiation conductor layer on the glass surface so as not to be connected to the radiation conductor layer. In addition, a plurality of clearance holes serving as solder wells may be formed at plural places in the dielectric layer corresponding to the dummy electrodes, and the brim may be soldered to the dummy electrodes by solders within the clearance holes. Accordingly, assembling strength of the bracket to the glass surface is increased and the thin dielectric plate is also reliably fixed while being positioned. Therefore, reliability can be improved. Further, the dummy electrodes, the radiation conductor layer or the capacitor electrodes can be collectively formed on the glass surface.

**[0011]** Further, in the planar antenna device according to the invention, lands may be formed on both surfaces of the dielectric layer so as to face the capacitor electrodes or the flat capacitor plate, and the lands may be individually adhered to the capacitor electrodes or the flat capacitor plate by a conductive adhesive. Therefore, the capacitance value of the capacitively coupled portion can be stabilized.

**[0012]** Further, in the planar antenna device according to the invention, the circuit board may have the ground conductor layer disposed provided on one surface so as to face the radiation conductor layer and an electronic circuit unit provided on the other surface, and the circuit board may be held in the bracket. According to this configuration, it is possible to use a reliable feed structure which connects a feed point of the radiation conductor layer and the electronic circuit unit of the circuit board to each other by a feed pin. In this case, if the electronic circuit unit includes a low-noise amplifying circuit, the low-noise amplifying circuit is electromagnetically shielded by the bracket formed of a metal plate. Therefore, the planar antenna device is suited to receive weak electrical waves of a GPS or the like.

**[0013]** Further, in the planar antenna device according to the invention, the glass surface may be an inner surface of a window glass of a vehicle. According to this configuration, the planar antenna device can be installed within the vehicle, and thus there is no case in which the

field of vision is obstructed.

## BRIEF DESCRIPTION OF THE DRAWINGS

5 **[0014]**

FIG. 1 is a cross-sectional view of a planar antenna device according to a first embodiment of the invention;

10 FIG. 2 is a cross-sectional view showing the main parts of a capacitively coupled portion of the first embodiment;

FIG. 3 is an exploded perspective view of the antenna device shown in FIG. 1;

15 FIG. 4 is a front view of the antenna device shown in FIG. 1;

FIG. 5 is a front view of a planar antenna device according to a second embodiment of the invention;

20 FIG. 6 is a perspective view of a dielectric layer used in the second embodiment;

FIG. 7 is a cross-sectional view showing the main parts of a soldered portion in the second embodiment;

25 FIG. 8 is a cross-sectional view showing the main parts of a capacitively coupled portion in a planar antenna device according to a third embodiment of the invention; and

FIG. 9 is a perspective view of a dielectric layer used in the third embodiment.

30

## DESCRIPTION OF THE PREFERRED EMBODIMENT

**[0015]** Preferred embodiments of the invention will now be described with reference to the drawings. FIG. 1 is a cross-sectional view of a planar antenna device according to a first embodiment of the invention. FIG. 2 is a cross-sectional view showing main parts of a capacitively coupled portion of the antenna device. FIG. 3 is an exploded perspective view of the antenna device. FIG. 4 is a front view of the antenna device. In FIG. 4, a glass plate is not shown.

**[0016]** The planar antenna device shown in the drawings is, for example, a circularly polarized antenna for a vehicle suitable as an antenna for a GPS, and is installed on a window glass (glass plate), such as a front glass of a vehicle. The planar antenna device primarily includes a radiation conductor layer 2 and four capacitor electrodes 3 which are printed on an inner surface 1a of a window glass 1 of a vehicle, a circuit board 4 which is disposed at a position facing the radiation conductor layer 2 at a predetermined gap, and a metal bracket 5, formed of a metal plate, which has a boxlike body 5a for housing and holding the circuit board 4 and is attached to the surface 1a of the window glass 1 by a both-sided adhesive sheet 9. One end of a feed pin 6 is soldered to a feed point of the radiation conductor layer 2. Further, a ground conductor layer 7 formed of copper foil is provided on a surface facing the radiation conductor layer 2 of both

surfaces of the circuit board 4, and an electronic circuit unit 8 including a low-noise amplifying circuit is provided on the other surface.

**[0017]** As shown in FIG. 4, the radiation conductor layer 2 is formed to substantially have a rectangular shape with two of four corners notched, and the pair of notched portions form degeneracy splitting elements 2a. A phase difference of 90° is generated between electric field modes in diagonal directions perpendicular to each other, whereby circularly polarized waves can be radiated by one point power feed. The capacitor electrodes 3 are land-shaped conductive regions extending outward the middles of four sides of the radiation conductor layer 2. The capacitor electrodes 3 and the radiation conductor layer 2 are collectively printed with silver paste or the like on the surface 1a of the window glass. In addition, the other end of the feed pin 6 passes through the circuit board 4 to be then soldered to the electronic circuit unit 8.

**[0018]** The ground conductor layer 7 is substantially provided on the entire surface of the circuit board 4 and faces the radiation conductor layer 2 with an air layer interposed therebetween. The ground conductor layer 7 has a diameter slightly larger than that of the radiation conductor layer 2 and has a relief portion 7a (see FIG. 3) at a position corresponding to the feed pin 6, whereby the ground conductor layer 7 does not come into contact with the feed pin 6. Further, the electronic circuit unit 8 provided on the other surface of the circuit board 4 is connected to an external circuit, such as a receiving circuit or the like, through an inner conductor of a coaxial cable (not shown) and includes a low-noise amplifying circuit with various electronic components mounted thereon. Therefore, the planar antenna device is suited to receive weak electric waves from a GPS or the like.

**[0019]** The bracket 5 is formed by pressing a metal plate so as to have a shape with a brim 5b provided in the boxlike body 5a having a bottom, and the circuit board 4 is held in the boxlike body 5a. The brim 5b is provided in the periphery of an opening end of the boxlike body 5a so as to surround the radiation conductor layer 2, as shown in FIGS. 1 and 4. The brim 5b is adhered and fixed to the surface 1a of the window glass 1 by a both-sided adhesive sheet 9. As shown in the expanded view of FIG. 2, the both-sided adhesive sheet 9 is made by coating adhesive layers on both surfaces of a thin base layer (dielectric layer) 9a formed of a dielectric. As a material for the adhesive layers, an UV cure adhesive or a thermosetting adhesive is suitably used. The brim 5b of the bracket 5 fixed to the window glass 1 by the both-sided adhesive sheet 9 closely faces the capacitor electrodes 3, and the thin base layer 9a formed of a dielectric is interposed between the brim 5b and the capacitor electrodes 3. Further, the bracket 5 is connected to the ground conductor layer 7, and the bracket 5 and the ground conductor layer 7 are connected to a ground through an outer conductor of the coaxial cable (not shown). Therefore, at the time of power feed, additional capacitance is generated between the capacitor electrodes 3 extending out-

ward from the radiation conductor layer 2 and the brim 5b of the bracket 5. Moreover, the electronic circuit unit 8 including the low-noise amplifier circuit is covered with the bracket 5 so as to be electromagnetically shielded.

Therefore, noise due to unexpected external electric waves rarely has influence on the electronic circuit unit 8.

**[0020]** As such, in the planar antenna device according to this embodiment, since the radiation conductor layer 2 is provided on the surface 1a of the window glass 1 of the vehicle, the reduction in size can be realized by using a wavelength shortening effect of the glass plate (window glass 1). Further, the capacitor electrodes 3 extending outward from the edges of the radiation conductor layer 2 are capacitively coupled with the brim 5b of the bracket 5 serving as a ground. Therefore, a resonance frequency of the radiation conductor layer 2 can be reduced, which is also of advantage to the reduction in size. Further, the base layer 9a of the both-sided adhesive sheet 9 is used as a dielectric layer interposed in the capacitively coupled portion. Therefore, the number of components can be reduced and favorable assembling workability can be obtained. As a result, the planar antenna device can remove an expensive dielectric substrate and suppress the component cost, and can be easily reduced in size. Further, even when the antenna device is installed on the window glass 1 of the vehicle, there is no case in which the field of vision is obstructed. Moreover, since the planar antenna device is used while being mounted on the window glass 1, there is little spatial restriction for installation in the vehicle. In addition, there is no case in which the field of vision is obstructed, as compared with a case in which the device is provided on a dashboard or the like.

**[0021]** FIG. 5 is a front view of a planar antenna device according to a second embodiment of the invention. FIG. 6 is a perspective view of a dielectric layer used in the antenna device. FIG. 7 is a cross-sectional view showing the main parts of a soldered portion of the antenna device. In FIG. 5, a glass plate is not shown. Further, in FIGS. 5 to 7, the same parts as those in FIGS. 1 to 4 are represented by the same reference numerals, and the descriptions thereof will be omitted.

**[0022]** The planar antenna device shown in FIG. 5 uses a thin dielectric plate (dielectric layer) 10, which is formed to have a rectangular shape so as to cover the radiation conductor layer 2 and the capacitor electrodes 3 and faces the brim 5b of the bracket 5 at the outer edge. Dummy electrodes 11 are provided at four places on the surface 1a of the window glass 1 outside the four corners of the radiation conductor layer 2 so as not to be connected to the radiation conductor layer 2. The thin dielectric plate 10 is formed of a dielectric material having high heat resistance, and clearance holes 10a serving as solder wells are formed at the positions of the thin dielectric plate corresponding to the dummy electrodes 11 at four corners of the outer edge. Further, clearance holes 10c (see FIG. 7) serving as solder wells are formed at four corners of the brim 5b of the bracket 5 corresponding to the clearance holes 10a. At the time of assembling,

the thin dielectric plate 10 and the bracket 5 are laminated on the surface 1a of the window glass 1, and the clearance holes 10a and 5c are aligned with the dummy electrodes 11. In this state, solders 12 are filled in the clearance holes 10a and 5c. In such a manner, the brim 5b of the bracket 5 is soldered to the dummy electrodes 11, whereby assembling strength of the bracket 5 to the window glass 1 is increased. Further, the thin dielectric plate 10 interposed between the brim 5b and the window glass 1 is also reliably positioned and fixed. Therefore, it is possible to increase mechanical strength of the planar antenna device which can be reduced in size and can be manufactured at low cost. Further, the dummy electrodes 11 and the radiation conductor layer 2 or the capacitor electrodes 3 can be collectively formed on the surface 1a of the window glass 1.

**[0023]** FIG. 8 is a cross-sectional view showing the main parts of a capacitively coupled portion of a planar antenna device according to a third embodiment of the invention. FIG. 9 is a perspective view of a dielectric layer used in the antenna device. In FIGS. 8 and 9, the same parts as those in FIGS. 2 and 6 are represented by the same reference numerals, and the descriptions thereof will be omitted.

**[0024]** The planar antenna device shown in FIG. 8 uses a thin frame-shaped dielectric plate (dielectric layer) 13 having the almost same shape as the brim 5b of the bracket 5. The thin dielectric plate 13 is interposed between the brim 5b and the surface 1a of the window glass 1. Though not shown in FIG. 8, dummy electrodes are provided at four places on the surface 1a of the window glass 1 outside four corners of the radiation conductor layer 2 so as not to be connected to the radiation conductor layer 2 in the same manner as the second embodiment. On a surface of the thin dielectric plate 13 close to the window glass 1, there are provided lands 13a which are formed at positions corresponding to the capacitor electrodes 3 or the dummy electrodes. Further, on a surface of the thin dielectric plate 13 close to the brim 5b, lands 13b are provided to correspond to the lands 13a. The lands 13a are correspondingly adhered to the capacitor electrodes 3 or the dummy electrodes by a conductive adhesive 14, and the land 13b are also adhered to the brim 5b by the conductive adhesive 14. Specifically, in the capacitively coupled portion of the planar antenna device, the capacitor electrodes 3 and the lands 13a are electrically and mechanically connected to each other and the brim 5b and the lands 13b are electrically and mechanically connected to each other. Therefore, the capacitance value of the capacitively coupled portion is stable, thereby easily obtaining desired antenna characteristics. Moreover, the dummy electrodes and the capacitor electrodes 3 can be collectively formed, and an adhesion work by the conductive adhesive 14 can be performed at the same time. Therefore, when the dummy electrodes are provided, the mechanical strength of the planar antenna device can be improved, without increasing the number of manufacturing steps.

**[0025]** In addition, in the above-described embodiments, a circularly polarized antenna for a vehicle appropriate as an antenna for a GPS has been illustrated. Alternatively, in case of an antenna for an ETC, the thickness of a bracket can be reduced by removing a low-noise amplifying circuit. Further, the invention is not limited to the circularly polarized antenna but can be applied to a linearly polarized antenna.

**[0026]** In the planar antenna device according to the invention, by providing the radiation conductor layer on the surface of the window glass of the vehicle, an exclusive-use dielectric substrate can be removed. Further, the resonance frequency of the radiation conductor layer can be lowered by capacitively coupling the capacitor electrodes extending outward from the edges of the radiation conductor layer with the flat capacitor plate of the bracket serving as the ground. Therefore, the reduction in size can be easily realized, and the component cost can be reduced. Further, since the planar antenna device can be used while being mounted on the glass surface of the window glass or the like, there is little spatial restriction for installation in the vehicle, and there is no case in which the field of vision is obstructed.

## Claims

### 1. A planar antenna device comprising:

- a radiation conductor layer (2) which is provided on a glass surface (1a) of an installed apparatus; capacitor electrodes (3) which are provided on the glass surface (1a) so as to extend outward from the edges of the radiation conductor layer (2);
- a ground conductor layer (7) which faces the radiation conductor layer (2) with an air layer interposed therebetween;
- a bracket (5), formed of a metal plate, which has a flat capacitor plate (5b) closely facing the capacitor electrodes (3) and is mounted on the glass surface (1a) with a circuit board (4) housed and held therein; and
- a dielectric layer (9a) which is interposed between the capacitor electrodes (3) and the flat capacitor plate (5b),

wherein the ground conductor layer (7) and the bracket (5) are electrically connected to each other, and the capacitor electrodes (3) and the flat capacitor plate (5b) are capacitively coupled with each other.

2. The planar antenna device according to claim 1, wherein the bracket (5) has a brim (5b) adhered to the glass surface (1a), and a part of the brim (5b) forms the flat capacitor plate (5b).
3. The planar antenna device according to claim 2,

wherein the dielectric layer (9a) is a base layer (9a) of a both-sided adhesive sheet (9), the both-sided adhesive sheet (9) is interposed between the glass surface (1a) and the brim (5b), and the brim (5b) is adhered and fixed to the glass surface (1a) by adhesive layers (9b) provided on both surfaces of the base layer (9a). 5

4. The planar antenna device according to claim 2, wherein a plurality of dummy electrodes (11) are distributed in the periphery of the radiation conductor layer (2) on the glass surface (1a) so as not to be connected to the radiation conductor layer (2), a plurality of clearance holes (10a) serving as solder wells are formed at plural places in the dielectric layer (9a) corresponding to the dummy electrodes (11), and the brim (5b) is soldered to the dummy electrodes (11) by solders within the clearance holes (10a). 10 15
5. The planar antenna device according to claim 1, wherein lands (13a, 13b) are provided on both surfaces of the dielectric layer (9a) so as to face the capacitor electrodes (3) or the flat capacitor plate (5b), and the lands (13a, 13b) are adhered to the capacitor electrodes (3) or the flat capacitor plate (5b) by a conductive adhesive (14). 20 25
6. The planar antenna device according to claim 1, wherein the circuit board (4) has the ground conductor layer (7) provided on one surface and an electronic circuit unit (8) provided on the other surface, and the circuit board (4) is housed in the bracket (5). 30
7. The planar antenna device according to claim 6, wherein the electronic circuit unit (8) includes a low-noise amplifying circuit. 35
8. The planar antenna device according to claim 1, wherein the glass surface (1a) is an inner surface 1a of a window glass 1 of a vehicle. 40

45

50

55

FIG. 1

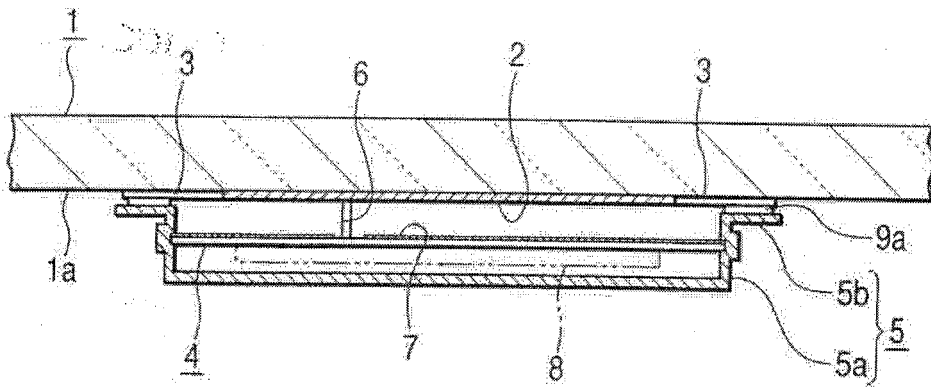

FIG. 2

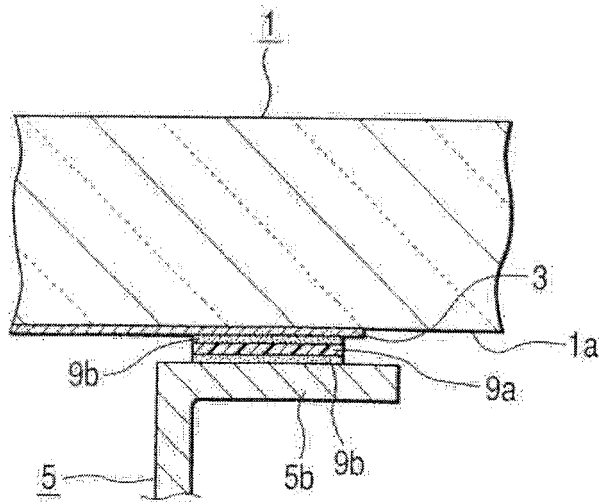

FIG. 3

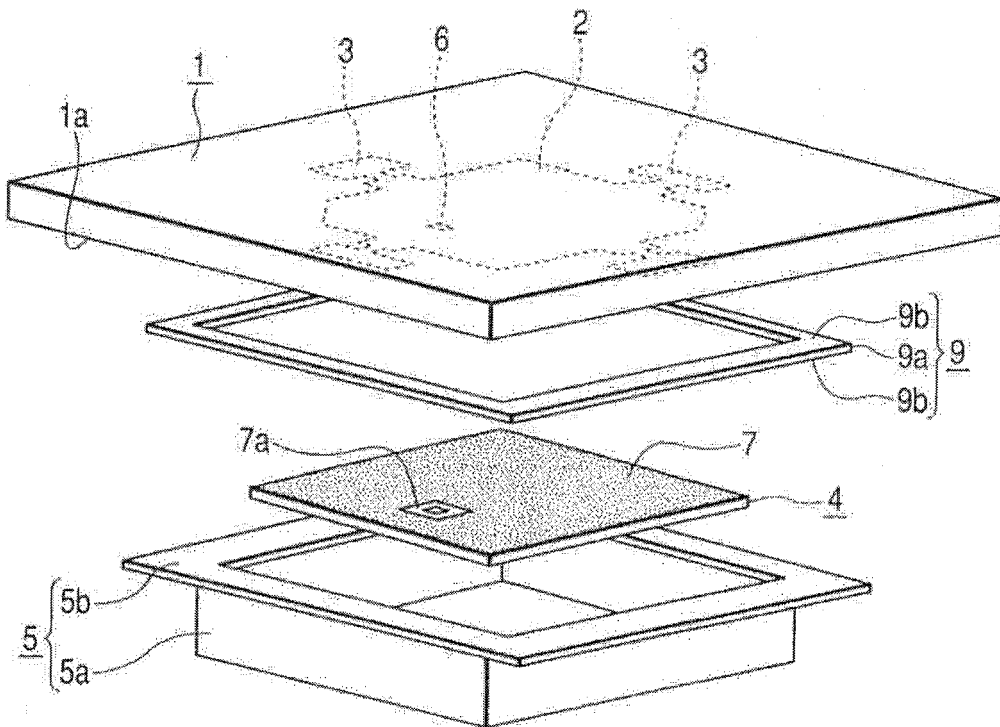

FIG. 4

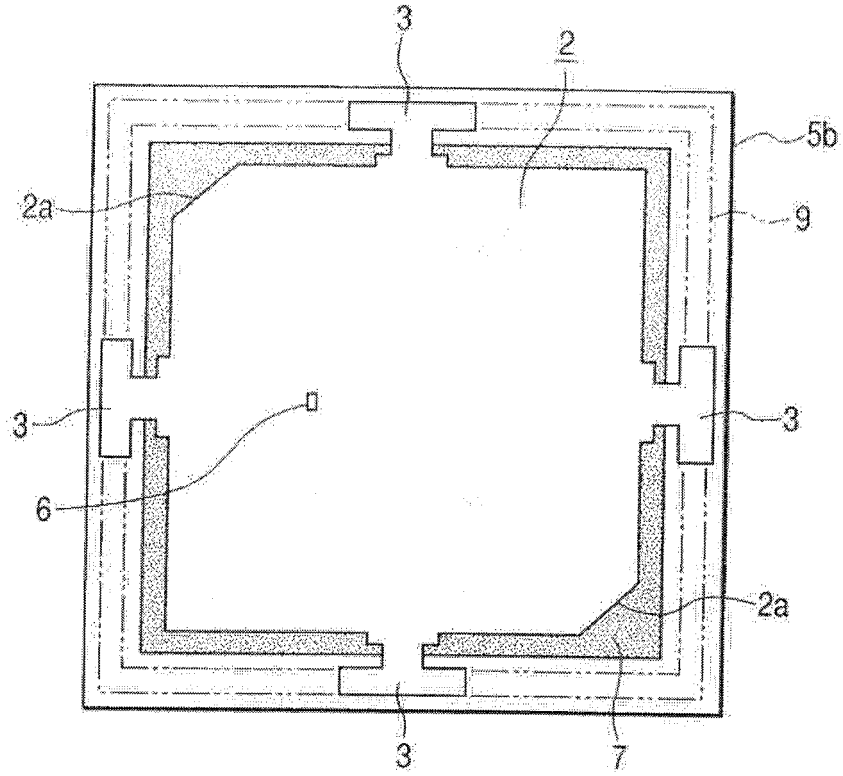

FIG. 5

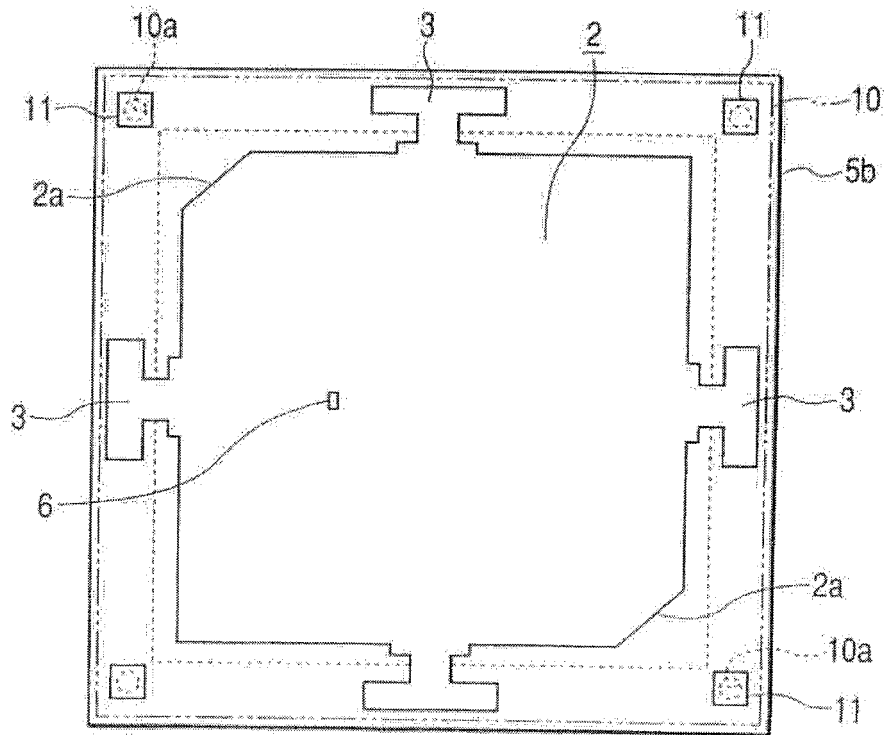

FIG. 6

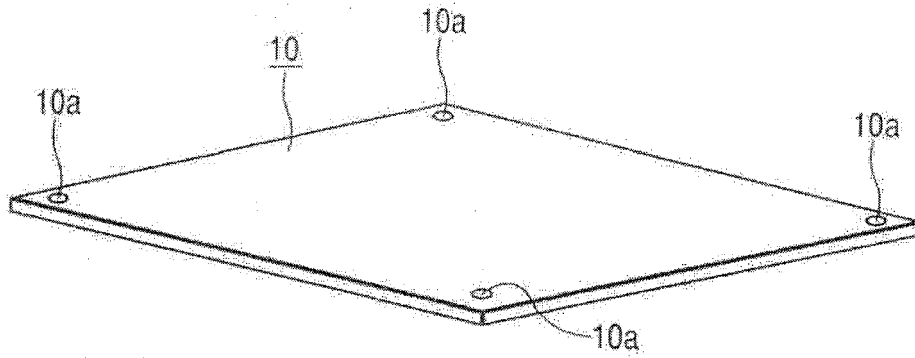

FIG. 7

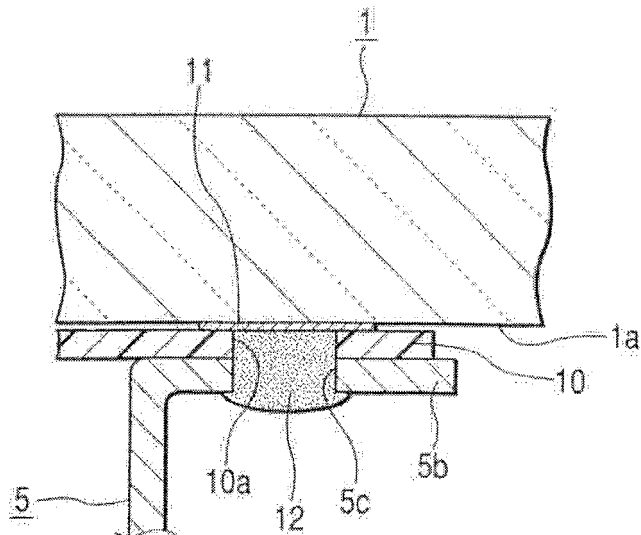

FIG. 8

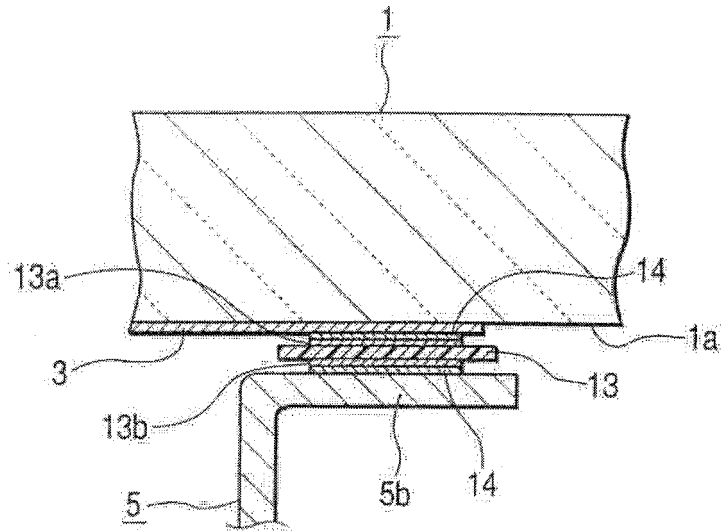
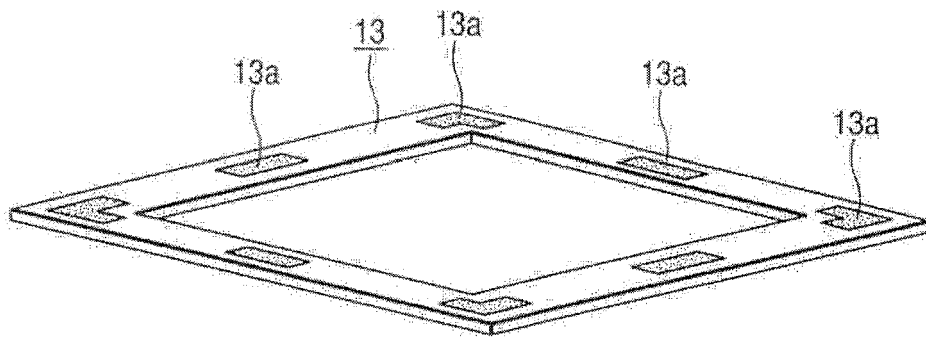

FIG. 9





DOCUMENTS CONSIDERED TO BE RELEVANT			
Category	Citation of document with indication, where appropriate, of relevant passages	Relevant to claim	CLASSIFICATION OF THE APPLICATION (IPC)
A	WO 02/063334 A (ROBERT BOSCH GMBH; SCHMIDT, EWALD; PFIZENMAIER, HEINZ; LEUTZ, STEFFEN;) 15 August 2002 (2002-08-15) * page 7, line 23 - page 13, line 2 * * figures 1-4 * -----	1,2,6-8	INV. H01Q9/04 H01Q1/52
A	EP 1 530 254 A (ALPS ELECTRIC CO., LTD) 11 May 2005 (2005-05-11) * paragraphs [0011] - [0014] * * figures 1-3 * -----	1,5	
			TECHNICAL FIELDS SEARCHED (IPC)
			H01Q
The present search report has been drawn up for all claims			
Place of search Munich		Date of completion of the search 24 August 2006	Examiner Kruck, P
CATEGORY OF CITED DOCUMENTS X : particularly relevant if taken alone Y : particularly relevant if combined with another document of the same category A : technological background O : non-written disclosure P : intermediate document		T : theory or principle underlying the invention E : earlier patent document, but published on, or after the filing date D : document cited in the application L : document cited for other reasons ..... & : member of the same patent family, corresponding document	

1  
EPO FORM 1503 03.82 (P04G01)

**ANNEX TO THE EUROPEAN SEARCH REPORT  
ON EUROPEAN PATENT APPLICATION NO.**

EP 06 11 2014

This annex lists the patent family members relating to the patent documents cited in the above-mentioned European search report. The members are as contained in the European Patent Office EDP file on  
The European Patent Office is in no way liable for these particulars which are merely given for the purpose of information.

24-08-2006

Patent document cited in search report		Publication date	Patent family member(s)	Publication date
WO 02063334	A	15-08-2002	EP 1410062 A2	21-04-2004
-----				
EP 1530254	A	11-05-2005	JP 2005143027 A	02-06-2005
			US 2005093748 A1	05-05-2005
-----				

EPC FORM P0459

For more details about this annex : see Official Journal of the European Patent Office, No. 12/82

**REFERENCES CITED IN THE DESCRIPTION**

*This list of references cited by the applicant is for the reader's convenience only. It does not form part of the European patent document. Even though great care has been taken in compiling the references, errors or omissions cannot be excluded and the EPO disclaims all liability in this regard.*

**Patent documents cited in the description**

- JP 2004088444 A [0003]