

# United States Patent

Hirschman

[15] 3,690,321

[45] Sept. 12, 1972

[54] **CATAMENIAL DEVICE**  
[72] Inventor: **Shalom Z. Hirschman**, 110-11  
Queens Blvd., Forest Hills, N.Y.  
11375

[22] Filed: **Oct. 15, 1970**

[21] Appl. No.: **81,057**

[52] **U.S. Cl.**.....128/285  
[51] **Int. Cl.**.....**A61f 13/20**  
[58] **Field of Search**.....128/270, 285, 290

[56] **References Cited**

**UNITED STATES PATENTS**

2,331,355 10/1943 Strongson.....128/285

2,652,056 9/1953 Lay.....128/285  
2,682,875 7/1954 Brown.....128/285  
3,037,506 6/1962 Penksa.....128/285  
3,420,234 1/1969 Phelps.....128/285

*Primary Examiner*—Charles F. Rosenbaum  
*Attorney*—Philip G. Hilbert

[57] **ABSTRACT**

A catamenial device including a tampon portion for insertion into the vaginal canal, and a pad portion integral with the tampon portion and extending transversely thereof, the pad portion being seated between the labia majora of the vulva.

**7 Claims, 11 Drawing Figures**

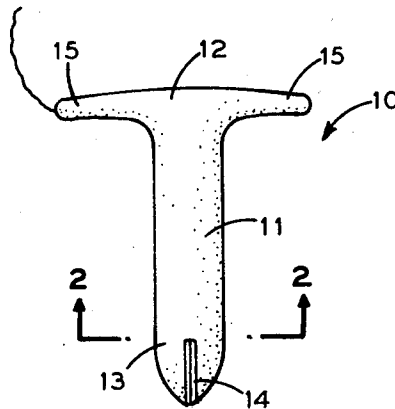

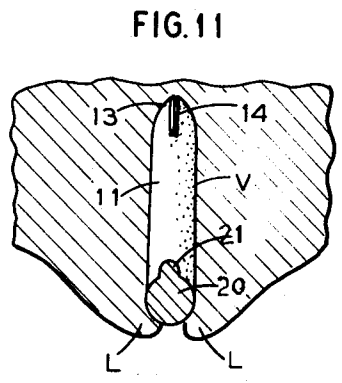
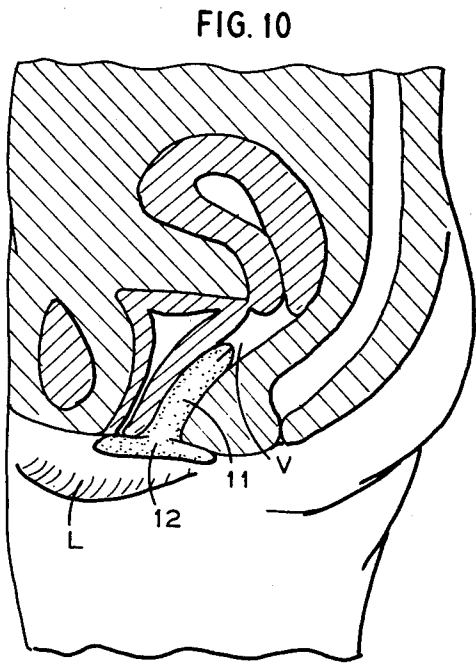
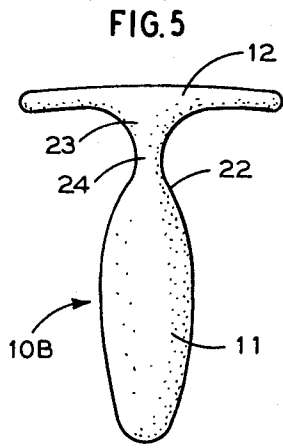
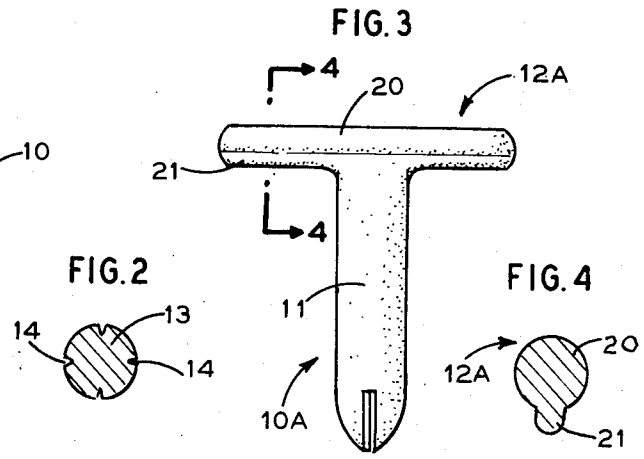
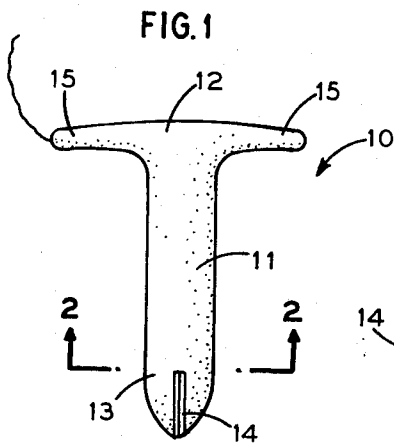

INVENTOR  
**Shalom Z. Hirschman**  
BY *Philip S. Hilbert*  
ATTORNEY

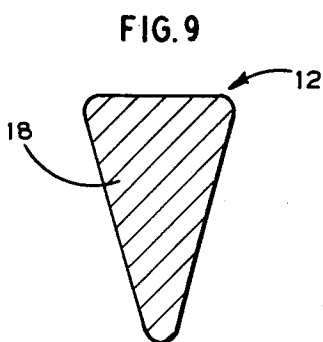
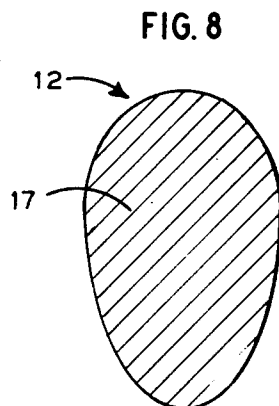
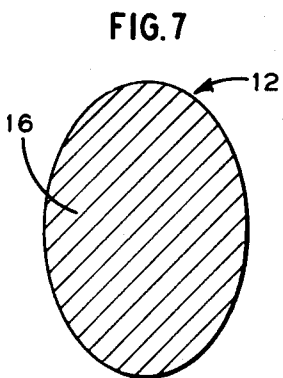
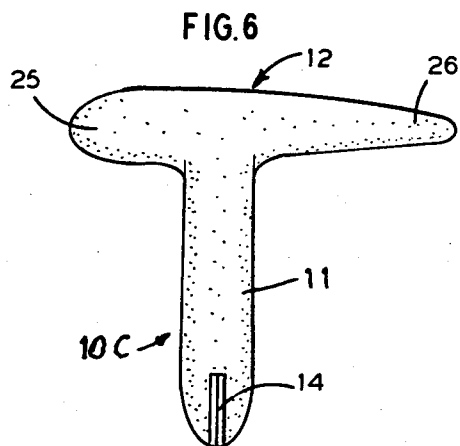

## CATAMENIAL DEVICE

## BACKGROUND OF THE INVENTION

The menstrual period is an exceedingly uncomfortable time interval for most women. Particularly, there is the need for maintaining garments free of the menstrual effluent and for overcoming the discomfort of the catamenial devices used and the release of undesirable odors therefrom.

Intravaginal catamenial tampon devices have won substantial acceptance by women. However, such known tampon devices present a number of problems. Thus, they are somewhat difficult to insert into the vaginal canal and require special inserting means, which usually take the form of elongated plastic plunger devices. Also, tampon devices have a tendency to swell as they absorb the menstrual effluent leading to (a) difficulty in removing the saturated tampon; and (b) leakage of the absorbed effluent due to squeezing of the device, resulting in soilage of garments and the like.

Accordingly, an object of this invention is to provide an improved catamenial device of the tampon type, which is of such a construction as to allow for insertion of the same within the vaginal canal without the need for inserting means.

Another object of this invention is to provide an improved tampon construction which lends itself to easy removal and prevents leakage of effluent around the tampon, thereby eliminating soilage of garments and the like.

Still another object of this invention is to provide an improved tampon construction which includes a sealant pad portion integral with the tampon portion disposed within the vaginal canal, the pad portion being located between the labia majora of the vulva.

Yet another object of this invention is to provide a tampon construction which has a high absorptive capacity for menstrual effluent, yet is free of undue swelling due to the absorbed effluent.

Yet a further object of this invention is to provide an improved tampon construction which does not tend to distend the normally constricted vaginal orifice despite the presence of the tampon portion within the vaginal canal.

Still a further object of this invention is to provide an improved catamenial device of the character described, which includes improved means for dispensing lubricant, deodorants, therapeutic compositions and the like, upon insertion of the device into the vaginal canal.

Still another object of this invention is to provide an improved tampon construction which is altogether concealed in use, which is comfortable to the user and which does not interfere with the daily routine of the user.

Other objects of this invention will in part be obvious and in part hereinafter pointed out.

## DESCRIPTION OF THE DRAWINGS

FIG. 1 is an elevational view of a catamenial device embodying the invention;

FIG. 2 is a transverse sectional view taken on the line 2—2 of FIG. 1;

FIG. 3 is an elevational view similar to that of FIG. 1, showing another embodiment of the invention;

FIG. 4 is a transverse sectional view taken on the line 4—4 of FIG. 3.

FIG. 5 is an elevational view showing still another embodiment of the invention;

FIG. 6 is an elevational view showing yet another embodiment of the invention;

FIGS. 7—9 show several cross sectional forms for the pad portion of the catamenial device;

FIG. 10 is a diagrammatic showing of the catamenial device in its normal anatomical disposition;

FIG. 11 is a plan view showing the catamenial device in relation to the vulva and vagina, when in use.

## BRIEF DESCRIPTION OF THE PREFERRED EMBODIMENTS

The catamenial device of the instant invention comprises essentially a tampon portion insertable into the vaginal canal, and a pad portion integral with the tampon portion which lies between the labia majora of the vulva.

Thus, as shown in FIG. 1, 10 designates a catamenial device embodying the invention. The same comprises a tampon portion 11 and a pad portion 12 extending transversely of the axis of the tampon portion and located at one end thereof. The device 10 is made of highly absorbent material such as cellulose wadding or the like, suitably rolled and molded to the desired T shaped configuration.

The tampon portion 11 may be of cylindrical shape, terminating in a tapered end portion 13. End portion 13 may be formed with a series of longitudinally extending, circumferentially spaced grooves 14. Grooves 14 are of tapered cross section such as a V shape or the like with the maximum transverse dimension at the outer surface of end portion 13. Grooves 14 are adapted to carry lubricant, deodorant or therapeutic compositions in a preferably viscous form.

To use device 10, the same is manually grasped at pad portion 12 and tampon portion 11 is directed into vaginal canal V. The tapered end portion 13 of device 10 will displace the labia majora L, L of the vulva and the force applied to pad portion 12 will act along the longitudinal axis of tampon portion 11 to insert the same in the vaginal canal V.

When the tampon portion 11 is fully inserted in the vaginal canal V, the pad portion 12 will lie between the labia majora L, L. The pad portion 12 has tapering ends 15. However, the cross section of pad ends 15 may take varying forms as shown in FIGS. 7-9, including the elliptical form 16; the egg shaped form 17; or the wedge shaped form 18.

Alternatively, as shown in FIGS. 3, 4; portion 12A of device 10A may comprise longitudinally extending portions 20, 21. The outermost portion 20 has a transverse section of somewhat larger dimensions than that of the innermost portion 21. The surfaces of pad portions 20, 21 are preferably curvilinear and may be either part circular as shown; or part elliptical. In either case the radial dimensions of the portion 20 are greater than that of portion 21.

As shown in FIG. 5, the catamenial device 10 B is similar to that shown in FIG. 1, except that the tampon portion 11 is tapered at its inner end 22 and then reversely tapered as at 23, at its juncture with pad portion 12. Thus, there is formed a constricted portion 24 at

the juncture of tapered portions 22, 23. It will be apparent that upon inserting device 10 B, in the manner previously described; the constricted portion 24 will be located at the vaginal orifice. This will leave the vaginal orifice in its normal constricted form, notwithstanding the presence of the tampon portion 11 in the vaginal canal V.

In all cases, the devices of the instant invention are effective, when inserted and in place, to seal the vaginal orifice by way of pad portion 12, to thereby prevent leakage of menstrual effluent. Also, the absorptive capacity of tampon portion 11, is augmented by the absorptive capacity of pad portion 12, to thereby minimize swelling of the tampon portion 11 and leackage of menstrual effluent.

The labia majora L, L of the vulva enclose the pad portion 12 to thereby retain device 10 in place and to avoid inadvertent movement of the tampon portion 11. Further the device 10 may be readily removed by way of pad portion 12. However, if desired, a string S may be attached to one end of pad portion 12 to facilitate removal of device 10.

Also, as shown in FIG. 6, device 10 C may take a modified form in respect to the pad portion 12. Thus, pad portion 12 may be tapered in cross section from end to end, providing a larger posterior portion 25 and a smaller anterior portion 26; which permits pad portion 12 to more closely approximate anatomical contours at the vulva.

The grooves 14 at the tapered end portion 13 of tampon portion 11, serve as a means for dispensing lubricant, deodorant or therapeutic compositions, in somewhat viscous form. The tapered cross section of such grooves allow for constriction of end portion 13 as the same is inserted into the vaginal canal V to thereby force the content of said grooves into contact with the wall surfaces of the vaginal canal. The pad portion 12 may be similarly grooved to carry similar compositions

for dispensing when said pad portion is in place between the labia majora L, L.

It is understood that the tampon portion 11 and pad portion 12 may be suitably perfumed, to mask undesirable odors; and to otherwise be impregnated with therapeutic compositions or the like.

I claim:

1. A catamenial device comprising a tampon portion disposable within the vaginal canal, and a pad portion integral with one end of said tampon portion and extending transversely of the longitudinal axis of the tampon portion, said pad portion having curvilinear surface portions and being disposable between the labia of the vulva.

2. A catamenial device as in claim 1 wherein said pad portion comprises longitudinally extending outer and inner portions, the outer portion having transverse dimensions greater then that of said inner portion.

3. A catamenial device as in claim 2 wherein each of the outer and inner pad portions have curvilinear surfaces.

4. A catamenial device as in claim 1 wherein the free end of said tampon portion is tapered, the tapered end portion of the tampon portion being formed with longitudinally extending grooves for carrying and dispensing a composition for application to the walls of the vaginal canal upon insertion of said tampon portion into the vaginal canal and constriction of the grooved portions thereof.

5. A catamenial device as in claim 1 wherein said pad portion is tapered from end to end to provide enlarged cross sectional portions at one end thereof and reduced cross sectional portions at the other end thereof.

6. A catamenial device as in claim 1 wherein said pad portion has tapering cross sectional portions extending to the opposite ends thereof.

7. A catamenial device as in claim 1 wherein said pad portion has a cross section of elliptical shape.

\* \* \* \* \*

40

45

50

55

60

65