



(12) APPLICATION

(19) NO

(21) 20161481

(13) A1

NORWAY

(51) Int Cl.

E04F 13/08 (2006.01)

E04B 1/74 (2006.01)

Norwegian Industrial Property Office

(21)	Application nr	20161481	(86)	Int.application.day and application nr	
(22)	Application day	2016.09.19	(85)	Entry into national phase	
(24)	Date from which the industrial right has effect	2016.09.19	(30)	Priority	2015.09.30, PL, P.414235
(41)	Available to the public	2017.03.31			
(71)	Applicant	WIDO-PROFIL Sp. z.o.o., ul. Mickiewicza 40, PL-32-400 MYSLENICE, Polen			
(72)	Inventor	Michal Czyz, ul. Sloneczna 7, PL-30-444 LIBERTOW, Polen			
(74)	Agent of attorney	Zacco Norway AS, Postboks 2003 Vika, 0125 OSLO, Norge			

(54) Title **Mounting bracket**

(57) Abstract

The L-shaped mounting bracket with a metal footing (1) with at least one hole for the mounting anchor and the metal support arm (2) perpendicular to the footing (1) with holes for fasteners characterised in that on the support arm (2) there is a thermal insulation plate (3) made of plastic surrounding the ending of the support arm (2), and on the outer surface of the plate (3) there is at least one location tongue (4) defining, together with the outer surface of the plate (3), the slot (5) for installation of the section shelf (6) in it, during assembly of the facade, and it has at least two through holes (7) overlapping the holes in the support arm.

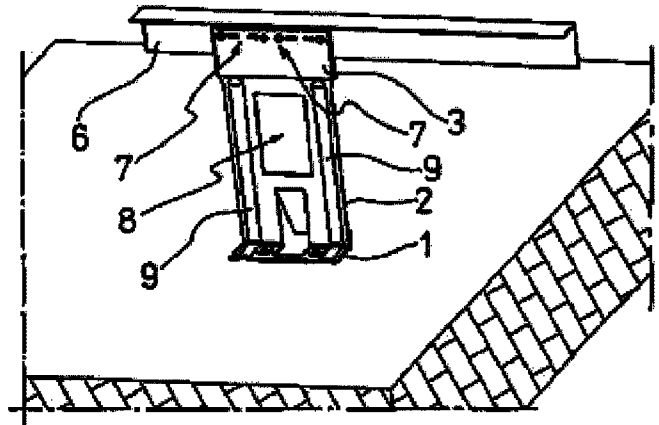

Mounting bracket

The present invention relates to bearing or support mounting bracket, for ventilated facade systems used in the construction industry.

The specifications of the Polish utility models PL 120099(U1) and PL 67635(Y1) and the European patent application EP 2746489 reveal metal mounting brackets used in ventilated facade systems. The known mounting brackets are L-shaped (angle) with arms of unequal length; the shorter arm forms the footing with at least one hole for an anchor or a similar mounting element used to attach the bracket to the space divider. In turn, the longer arm forms a bracket (outrigger) with at least two lugs at its end which together with the longer arm surface define the locating slots for installation, during the assembly of the facade, of the shelves of support sections supporting the cladding components of the facade. Moreover, the longer arm of the mounting bracket is equipped with at least two holes for fasteners with which the support sections are attached to the mounting bracket during the assembly of the facade.

In the temperate climatic zone the ventilated facade with heat loss preventing thermal insulation is widely used. Therefore a major technical issue is the reduction of the heat flow through thermal bridges of the support structures of such facade, including above all the mounting brackets.

The reduction of the heat flow through the mounting bracket is also possible by making holes in the longer arm to reduce the cross-section of the mounting bracket which is for example revealed in patent specification US 4495741.

In turn, as revealed, among others, in the European patent specification EP 2180115, to reduce the heat flow through metal elements of the facade it is suggested, for example, to use mounting brackets in the facades with metal footings at the ends and a support arm made of plastic with low thermal conductivity coefficient between them.

The inconvenience of this solution is connected with the risk that in the event of fire at the building the support arms of the mounting brackets may burn out and the entire support structure with facade panels may fall off of the wall.

To reduce the heat loss, there are also used metal mounting brackets with a support arm made of two separate parts, separated by a thermal barrier in the form of a cube or plate with holes, through which fasteners pass and connect both parts of the support arm of the mounting bracket. A solution of this type is revealed in the German patent applications DE 102012016025 and DE 102010061139 and in the specification of the European patent EP 2194208.

For example, according to the solution known from the German patent application DE 10201216025, the L-shaped metal mounting bracket has the footing with a hole for the mounting anchor, and a support arm that is perpendicular to footing and ends with two holes.

Moreover, the mounting bracket has a metal extension of the support arm which at its end, opposite to the footing, has two lugs defining, together with the extension surface, the slot for installation, during the facade assembly, of the shelf of the vertical support section supporting the facade

elements and near the ends of lugs there is a number of holes for mounting elements with which the section is combined with the mounting bracket during the facade erection. There is an insulating barrier between the ends of the arm of the known mounting bracket and its extension, and the arm of the mounting bracket, the insulating barrier and the extension are combined with the use of threaded fasteners passing through coaxial holes of the bracket, the barrier and the extension.

In turn, other mounting bracket solution intended to reduce the heat loss is revealed in the specification of the German utility model DE 202004008376. According to this solution the mounting bracket has two functional parts combined with each other. The first part of the mounting bracket comprises a C-shaped section in which the arm of the second part of the mounting bracket may be installed, in the form of an angle with unequal arm length with one arm used to attach it to the building wall and the other, longer arm, used to insert it inside the C-shaped element of the first part of the mounting bracket. The separate insulating layer is provided inside the C-shaped element of the first part of the mounting bracket to prevent direct contact of the C-shaped element and the angle arm, and thus create a thermal barrier between both parts of the mounting bracket.

These types of solutions revealed in the German patent applications DE 102012016025 and DE 102010061139, the specification of the European patent EP 2194208, and the specification of the German utility model DE 202004008376 eliminate the risk of facade falling off in case of fire. But their use in ventilated facades insulated with mineral wool causes the freezing of the mineral wool layer in the area surrounding the bracket arm protruding from it. It happens usually when the insulation layer is so thick that the

insulating fastener of the mounting bracket arm is located inside it, and the part of the arm that protrudes from the wool layer is connected directly with the metal sections creating a support structure of the facade panels.

The purpose of the invention is to deliver a mounting bracket in the form of an angle that eliminates the inconveniences of known solutions connected with fire risks and the phenomenon of freezing of the mineral wool insulation layer in the area surrounding the mounting bracket arm that protrudes from it.

The set purpose was achieved in accordance with the invention because the metal L-shaped mounting bracket with a footing with at least one hole for the mounting anchor and support arm perpendicular to the footing finished with at least two holes, was equipped with a thermal insulation plate made of plastic and installed at the end of the mounting bracket arm. The plate has through holes overlapping the holes formed in the support arm and it is also equipped with tongues defining the locating slots for facade sections. The known fasteners pass through the through holes of the plate and the holes in the support arm to fix the shelf of the facade section to the mounting bracket installed in the plate slots.

According to the invention the L-shaped mounting bracket with a metal footing with at least one hole for the mounting anchor and the metal support arm perpendicular to the footing with holes for fasteners is characterised by a thermal insulation plate located at the end of the support arm that surrounds the ending of the support arm.

It reduces the risk of freezing of the mineral wool insulation layer in the area surrounding the mounting bracket arm that protrudes from it, in particular when the plate goes deep inside the mineral wool layer.

On the outer surface of the plate there is at least one location tongue defining, together with the outer surface of the plate, the slot for installation of the section shelf in it, during assembly of the facade, and it has at least two through holes overlapping the holes in the support arm.

The known fasteners pass through the through holes and the holes of the support arm to fix the shelf of the facade section installed in the plate slots to the mounting bracket, which in the event of fire in the building and melting of the insulation plate protects the facade structure against falling off of the building.

Moreover, it is preferable when in the support arm below the plate there is a shaped hole which allows to reduce the cross-section of the support arm through which the heat flows.

It is also preferable when the support arm, and preferably the support arm and the footing, have stiffening embossments which allow to reduce arm thickness and thus additionally reduce the heat flow through the mounting bracket arm.

It is also preferable when a supporting leg, made of the support arm material and the mounting bracket footing material, goes from the lower part of the arm at an angle, as it only slightly limits the mechanical properties of the section at the place of the cutout for the leg, but at the same time increases the stiffness of the mounting bracket attachment to the building wall, both vertically and horizontally with long outreach.

It is preferable when the plate and the support arm of the mounting bracket have round holes and oval holes which allow to use the mounting bracket as the bearing bracket (fixed attachment point - in the round hole) and as the support bracket (moving attachment point - in the oval hole).

The solution solves the raised technical issues. The mounting bracket structure is simple and durable and allows to limit the number of thermal bridges and, in addition, it enables mounting bracket interaction with known insulation plates and insulation of the mounting anchor from the mounting bracket with the known separators.

In the examples of execution, the present invention was presented in the attached figure, where Fig.1 presents the mounting bracket in the first example of execution in the general view from the side of the footing, with the facade section attached to it; Fig.2 presents the mounting bracket in the first example of execution in the general view from the side of the supporting leg, with the facade section attached to it; Fig.3 presents the mounting bracket in the second example of execution in the general view from the side opposite the footing, with the facade section attached to it; Fig.4 presents a zoomed-in cross-section of the bracket according to the first example of execution.

The example of the L-shaped mounting bracket has a metal footing 1 with at least one hole for the mounting anchor and a metal support arm 2 perpendicular to the footing with holes for fasteners. At the end of the support arm 2 there is a thermal insulation plate 3 made of plastic surrounding the end of the support arm 2. On the outer surface of the plate 3 there are two location tongues 4 defining, together with the outer surface of the plate 3, the slots 5 for installation of the section shelf 6 in it during assembly of the facade. Moreover, the plate 3 has eight through holes 7 overlapping the holes made in the support arm 2, of which four are round and four are oval. The known threaded fasteners pass through the through holes 7 in the plate 3 and the holes in the support arm 2 to fix the section shelf 5 of the facade

installed in slots 6 to the bracket, and as shown in Fig.1, the said threaded fasteners are screwed in the round holes in the plate. Moreover, in the support arm 2 below the plate 3 there is a quadrangular hole 8 which allows to reduce the cross-section of the support arm through which the heat flows. The support arm 2 and the footing 1 of the mounting bracket have the stiffening embossments 9 which allow to reduce the thickness of the arm 2 and the footing 1 and thus additionally reduce the heat flow through the mounting bracket. In the first example of execution a supporting leg 10 made of the material of the support arm 2 and the mounting bracket footing 1 goes from the lower part of the support arm 2 at an angle. While in the second example of execution the mounting bracket has no supporting leg 10.

Claims

1. The L-shaped mounting bracket with a metal footing with at least one hole for the mounting anchor and the metal support arm perpendicular to the footing with holes for fasteners, characterised in that on the support arm (2) there is a thermal insulation plate (3) made of plastic, surrounding the ending of the support arm (2).
2. The mounting bracket according to claim 1 characterised in that on the outer surface of the plate (3) there is at least one location tongue (4) defining, together with the outer surface of the plate (3), the slot (5) for installation of the section shelf (6) in it, during assembly of the facade, and it has at least two through holes (7) overlapping the holes in the support arm (2).
3. The mounting bracket according to claim 1 characterised in that in the support arm (2) below the plate (3) there is a shaped hole (8).
4. The mounting bracket according to claim 1 characterised in that the support arm (2), and preferably the support arm (2) and the footing (1), have the stiffening embossments (9).

5. The mounting bracket according to claim 1 characterised in that a supporting leg (10) made of the material of the support arm (2) and the mounting bracket footing (1) goes from the lower part of the support arm (2) at an angle.

6. The mounting bracket according to claim 1 or 2 characterised in that the plate (3) and the support arm (2) of the mounting bracket have round holes and oval holes.

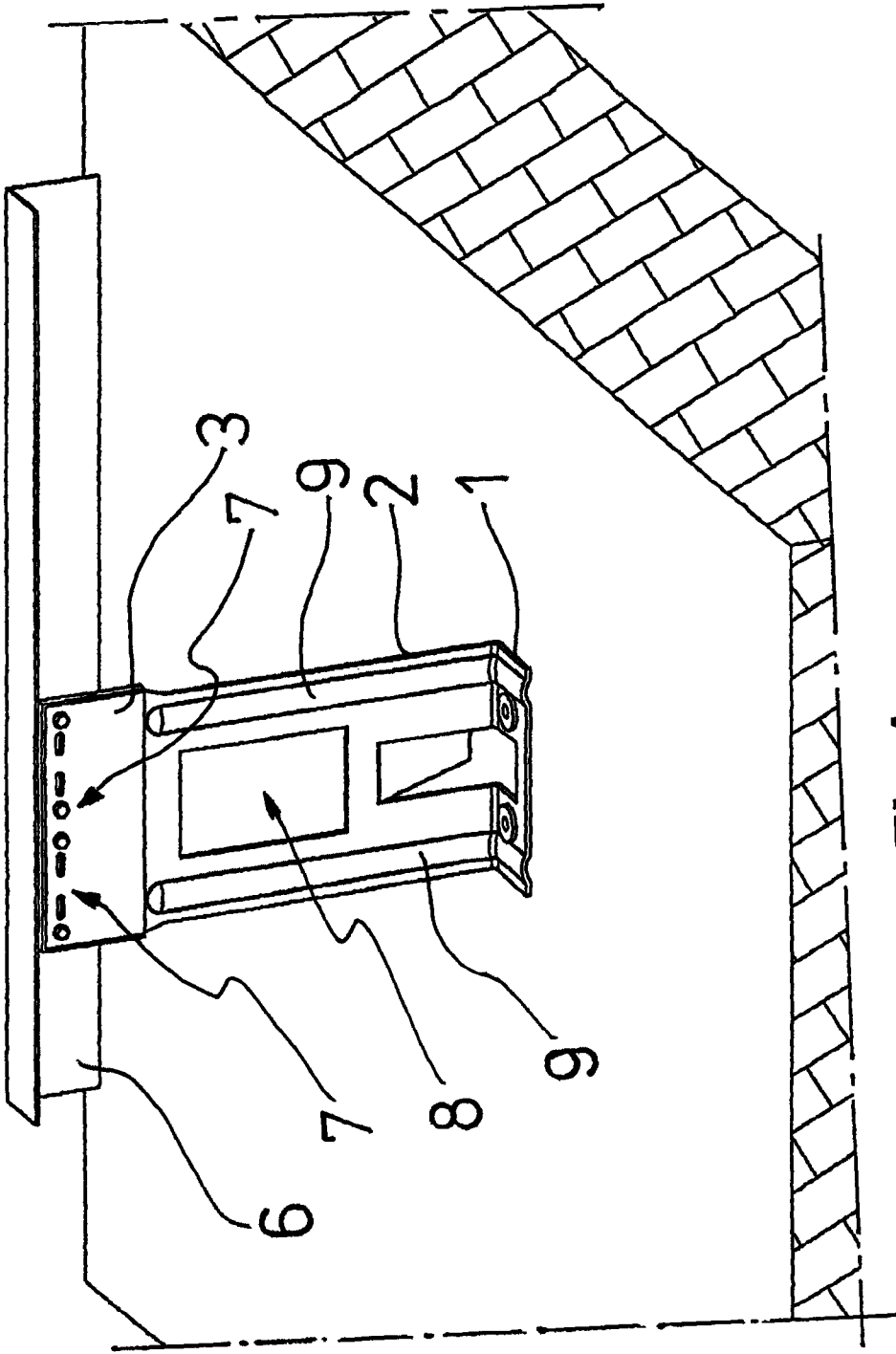

Fig.1

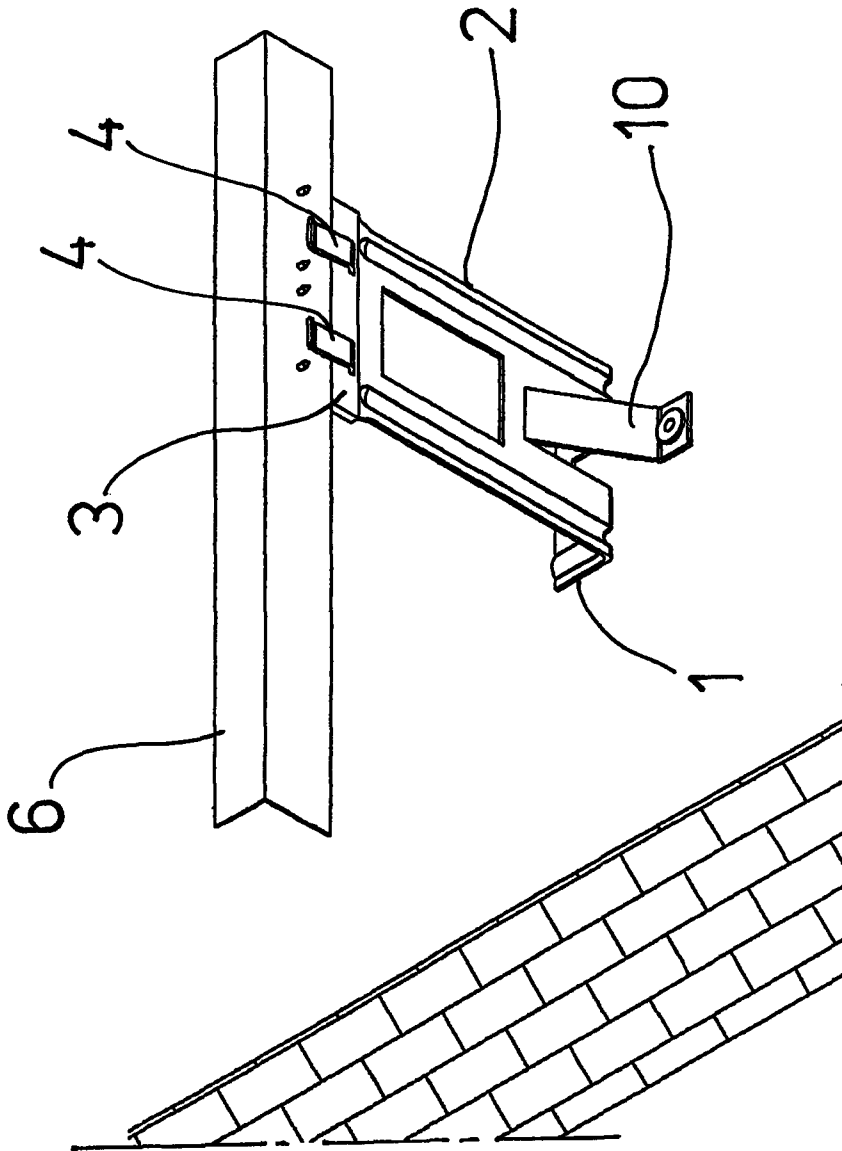

Fig.2

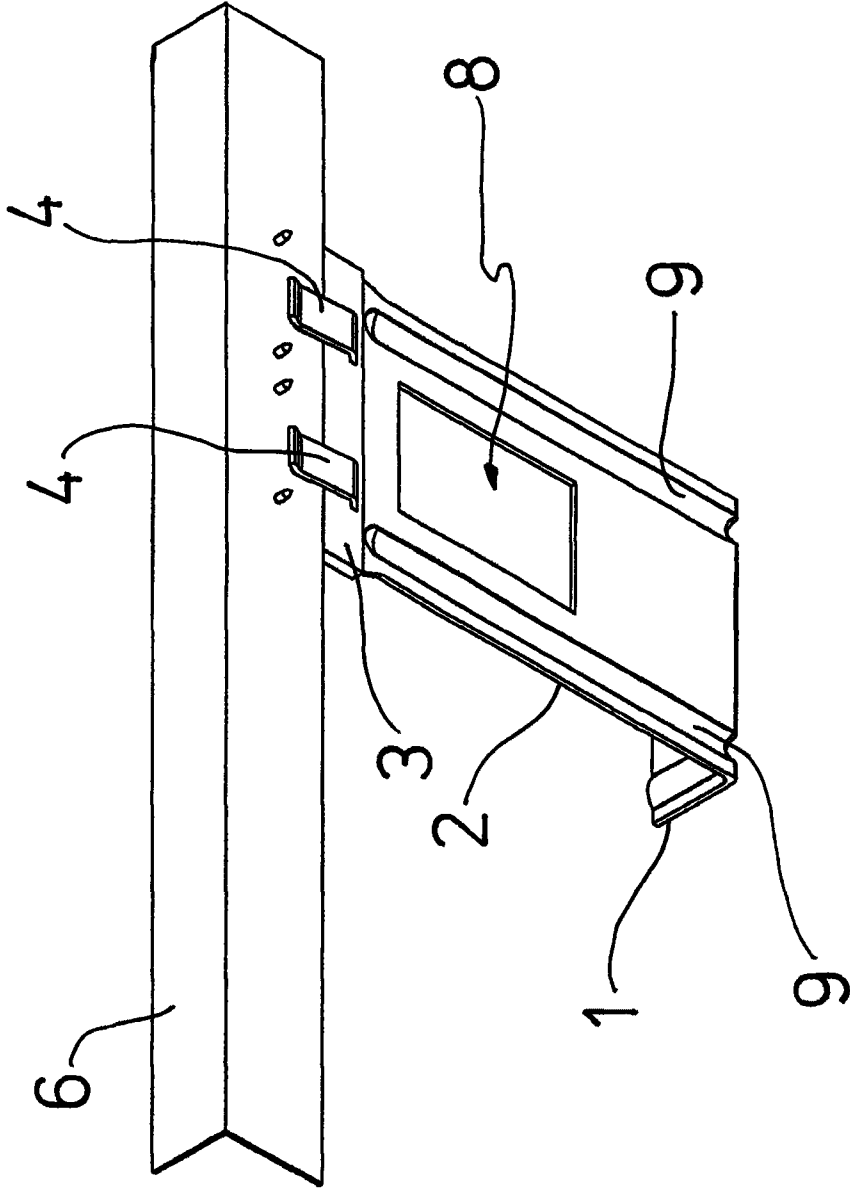

Fig.3

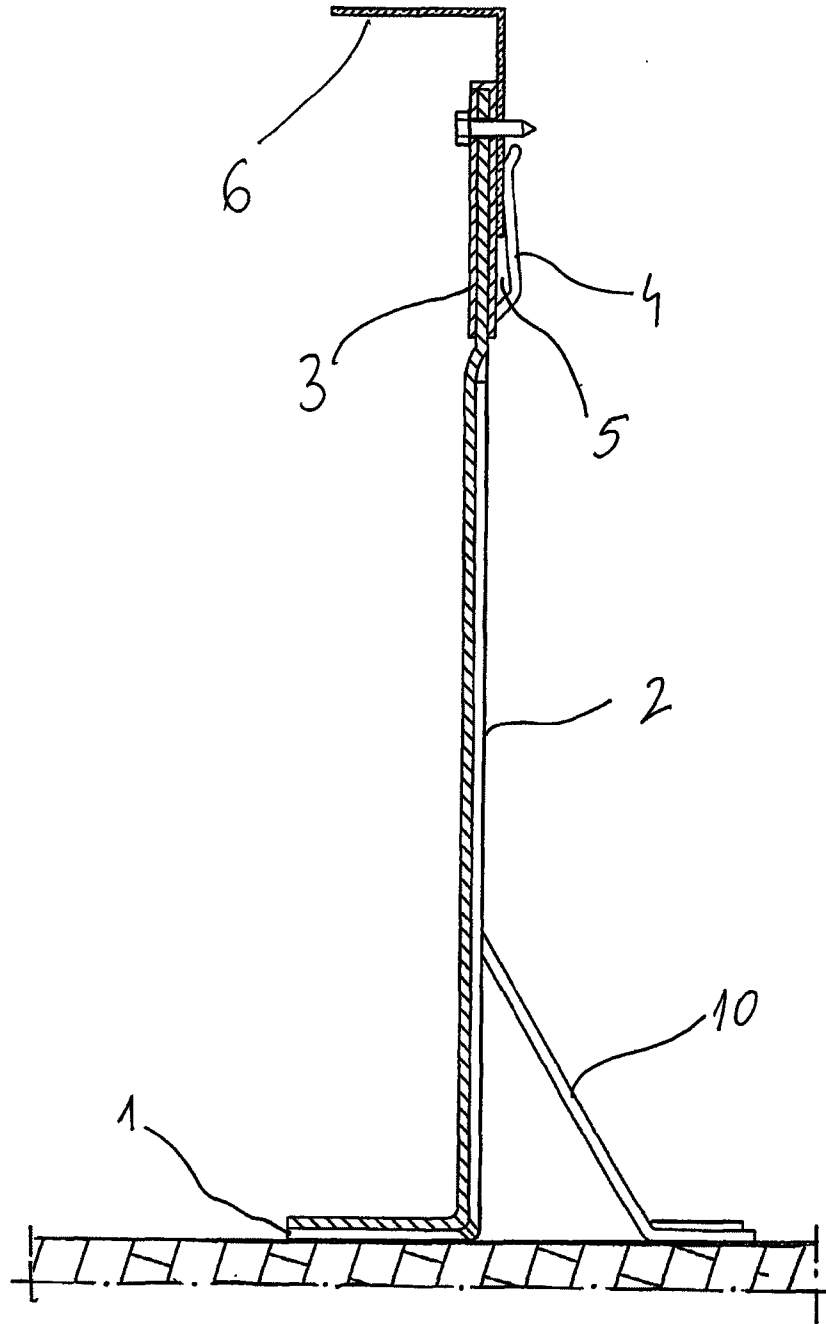

Fig.4