

(12) STANDARD PATENT
(19) AUSTRALIAN PATENT OFFICE

(11) Application No. **AU 2009278205 B2**

(54) Title
Container having a lid

(51) International Patent Classification(s)
B65D 25/16 (2006.01) **B65D 77/06** (2006.01)

(21) Application No: **2009278205** (22) Date of Filing: **2009.08.05**

(87) WIPO No: **WO10/015403**

(30) Priority Data

(31) Number	(32) Date	(33) Country
10 2008 036 988.8	2008.08.08	DE

(43) Publication Date: **2010.02.11**

(44) Accepted Journal Date: **2013.05.23**

(71) Applicant(s)
Mauser-Werke GmbH

(72) Inventor(s)
Schmidt, Klaus-Peter

(74) Agent / Attorney
FB Rice, Level 23 44 Market Street, SYDNEY, NSW, 2000

(56) Related Art
EP0691278

(12) NACH DEM VERTRAG ÜBER DIE INTERNATIONALE ZUSAMMENARBEIT AUF DEM GEBIET DES PATENTWESENS (PCT) VERÖFFENTLICHTE INTERNATIONALE ANMELDUNG

(19) Weltorganisation für geistiges Eigentum
Internationales Büro



(43) Internationales Veröffentlichungsdatum
11. Februar 2010 (11.02.2010)

PCT

(10) Internationale Veröffentlichungsnummer
WO 2010/015403 A1

(51) Internationale Patentklassifikation:
B65D 25/16 (2006.01) *B65D 77/06* (2006.01)

(21) Internationales Aktenzeichen: PCT/EP2009/005703

(22) Internationales Anmeldedatum:
5. August 2009 (05.08.2009)

(25) Einreichungssprache: Deutsch

(26) Veröffentlichungssprache: Deutsch

(30) Angaben zur Priorität:
10 2008 036 988.8
8. August 2008 (08.08.2008) DE

(71) Anmelder (für alle Bestimmungsstaaten mit Ausnahme von US): MAUSER-WERKE GMBH [DE/DE]; Schildgesstrasse 71-163, 50321 Brühl (DE).

(72) Erfinder; und

(75) Erfinder/Anmelder (nur für US): SCHMIDT, Klaus-Peter [DE/DE]; Roncallistrasse 10 B, 53123 Bonn (DE).

(74) Anwalt: HERFORTH, Klaus, E.; Mauser-Werke GmbH, Schildgesstrasse 71-163, 50321 Brühl, Allemagne (DE).

(81) Bestimmungsstaaten (soweit nicht anders angegeben, für jede verfügbare nationale Schutzrechtsart): AE, AG, AL, AM, AO, AT, AU, AZ, BA, BB, BG, BH, BR, BW, BY, BZ, CA, CH, CL, CN, CO, CR, CU, CZ, DE, DK, DM, DO, DZ, EC, EE, EG, ES, FI, GB, GD, GE, GH, GM, GT, HN, HR, HU, ID, IL, IN, IS, JP, KE, KG, KM, KN, KP, KR, KZ, LA, LC, LK, LR, LS, LT, LU, LY, MA, MD, ME, MG, MK, MN, MW, MX, MY, MZ, NA, NG, NI, NO, NZ, OM, PE, PG, PH, PL, PT, RO, RS, RU, SC, SD, SE, SG, SK, SL, SM, ST, SV, SY, TJ, TM, TN, TR, TT, TZ, UA, UG, US, UZ, VC, VN, ZA, ZM, ZW.

(84) Bestimmungsstaaten (soweit nicht anders angegeben, für jede verfügbare regionale Schutzrechtsart): ARIPO (BW, GH, GM, KE, LS, MW, MZ, NA, SD, SL, SZ, TZ, UG, ZM, ZW), eurasisches (AM, AZ, BY, KG, KZ, MD, RU, TJ, TM), europäisches (AT, BE, BG, CH, CY, CZ, DE, DK, EE, ES, FI, FR, GB, GR, HR, HU, IE, IS, IT, LT,

[Fortsetzung auf der nächsten Seite]

(54) Title: CONTAINER HAVING A LID

(54) Bezeichnung: DECKELBEHÄLTER

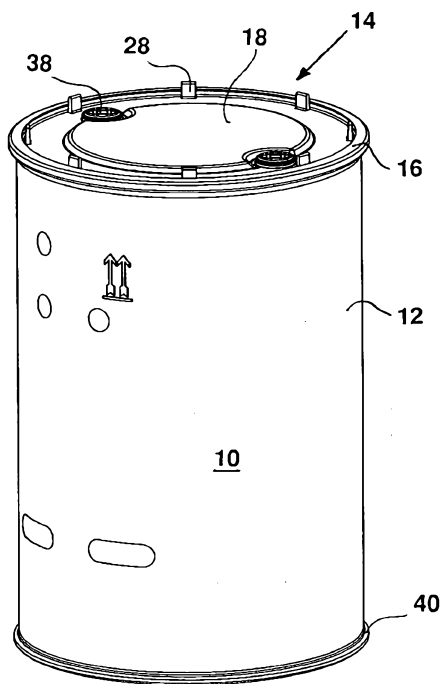

Figur 1

(57) Abstract: The invention relates to a container having a lid for storing and transporting in particular hazardous liquid filling materials, comprising an outer container body, an upper container lid and an inserted thin-walled inliner. The container lid comprises at least one filling and emptying opening that can be closed in a gas- and fluid-tight manner and that, for example, can be attached by means of a U-shaped clamping ring closure or without clamping ring as a snap cover by means of snap closure or a screw lid by means of screw closure on the upper container opening of the container body on a correspondingly designed flange edge. The thin-walled inliner (26) is fixed on the bottom side of the container lid (14) in the outer circumferential region in a gas- and fluid-tight manner, wherein the container lid (14) and inliner (26) form a gas- and fluid-tight hollow body unit. The container body, which can be used multiple times, is only provided as a support and protection unit for the inliner.

(57) Zusammenfassung: Die Erfindung betrifft einen Deckelbehälter zur Lagerung und zum Transport von insbesondere gefährlichen flüssigen Füllgütern, mit einem äußeren Behälterkörper, mit einem oberen Behälterdeckel und einem eingesetzten dünnwandigen Inliner. Der Behälterdeckel weist wenigstens eine gas- und flüssigkeitsdicht verschließbare Einfüll- und Entleerungsöffnung auf und kann z. B. mittels U-förmigem Spannringsverschluss oder ohne Spannring als Schnappdeckel mittels Schnappverschluss

[Fortsetzung auf der nächsten Seite]

WO 2010/015403 A1



LU, LV, MC, MK, MT, NL, NO, PL, PT, RO, SE, SI, SK, SM, TR), OAPI (BF, BJ, CF, CG, CI, CM, GA, GN, GQ, GW, ML, MR, NE, SN, TD, TG).

— *Erfindererklärung (Regel 4.17 Ziffer iv)*

Veröffentlicht:

— *mit internationalem Recherchenbericht (Artikel 21 Absatz 3)*

Erklärungen gemäß Regel 4.17:

— *hinsichtlich der Berechtigung des Anmelders, ein Patent zu beantragen und zu erhalten (Regel 4.17 Ziffer ii)*

oder als Schraubdeckel mittels Schraubverschluss auf der oberen Behälteröffnung des Behälterkörpers an einem entsprechend ausgebildeten Flanschrand befestigt sein. Dabei ist der dünnwandige Inliner (26) auf der Unterseite des Behälterdeckels (14) im äußeren Umfangsbereich gas- und flüssigkeitsdicht fixiert ist, wobei Behälterdeckel (14) und Inliner (26) eine gas- und flüssigkeitsdichte Hohlkörper-Einheit bilden und der mehrfach verwendbare Behälterkörper lediglich als Stütz- und Schutzeinheit für den Inliner dient.

LIDDED CONTAINER

[0001] The invention relates to a lidded container for storing and transporting in particular hazardous liquid fill goods, having an outer container body, an upper container lid and an inserted thin-walled inliner.

[0002] Prior Art:

[0003] Liquids, in particular hazardous liquid fill goods such as chemicals or the like, are typically filled in steel or plastic bunged drums. These steel or plastic bunged drums have a special UN approval in order to allow transport and storage of hazardous liquids therein. In order to receive a UN approval for drums, these drums have to pass certain tests (e.g. diagonal drop test, low-temperature drop test, internal pressure test, compression test, etc.) and meet particularly high performance standards.

[0004] Few lidded drums with UN approvals are already in existence which can be used, however, only for less hazardous liquids because a lidded drum (open top drum) is understandably not capable to have and meet the high drop strength and internal pressure resistance like a bunged drum (closed head drum).

[0005] Furthermore, the use of thin-walled inliners (film bags) in lidded drums is generally known, e.g. from DE-A 1009101 or DE-A 4321550. Attempts were even undertaken to equip bunged drums with inliners, as, e.g., known from DE 4007617 or EP-B 0 501 015. Inliners of this type are normally used to prevent a contamination of the container body and to thereby permit a reuse or multiple use of the outer container. In lidded drums, the inliners are always fixed in the mouth region or on the outer edge of the lidded container; in bunged drums, the inliners have oftentimes particular fastening sleeves on the filling and emptying opening for securement within the bung opening of the

drum. Placement of plastic liners in bunged drums and later removal is, however, extremely complicated and cumbersome and has not prevailed in practice.

[0006] Typically, filled lidded containers - even with inserted liners - can be used for hazardous liquids only to a limited extent, because of their exposure to high stress in the connection region from outer container body and upper container lid in the event of a drop of the container - in particular at a critical diagonal drop, causing frequently leakage - in particular when lidded plastic drums with tension ring closure of steel are involved, so that the range of applications of lidded drums is limited to non-hazardous particulate or pasty fill goods.

[0007] Any discussion of documents, acts, materials, devices, articles or the like which has been included in the present specification is not to be taken as an admission that any or all of these matters form part of the prior art base or were common general knowledge in the field relevant to the present disclosure as it existed before the priority date of each claim of this application.

[0008] Throughout this specification the word "comprise", or variations such as "comprises" or "comprising", will be understood to imply the inclusion of a stated element, integer or step, or group of elements, integers or steps, but not the exclusion of any other element, integer or step, or group of elements, integers or steps.

[0009] According to the present invention there is provided a lidded container for storing and transporting in particular hazardous liquid contents, having;

an outer container body,

an upper container lid, and

a thin-walled liner inserted in the container,

wherein the container lid can be fixed on an appropriately formed flange periphery

on the upper container opening of the container body by means of a U-shaped clamping ring closure or, without a clamping ring as a snap-fitting lid, by means of a snap fitting closure or, as a screw-fitting lid, by means of a screw closure,

wherein the container lid consists of thermoplastic material and is produced by injection moulding or blow moulding and has at least one relatively small lid opening, which can be closed in a gas-tight and liquid-tight manner by means of a closure lid and through which the liquid contents can be introduced and removed, and

wherein the thin-walled liner is welded or adhesively bonded in a gas-tight and liquid-tight manner to the outer circumferential region of the underside of the container lid wherein the container lid and the liner fixed thereon form a gas-tight and liquid-tight hollow-body unit, wherein the container lid has a U-shaped periphery which is open in the downward direction and has a vertical outer lid flange and a vertical inner flange, wherein the liner is welded or adhesively bonded, in a vertical fastening region to the outside of the inner lid flange.

[0010] In an embodiment of the invention, a fully closed container is created for receiving the liquid fill goods and is comprised with respect to a liquid tightness of the two essential components, liner and container lid, which are non-detachably connected to one another in a gas and liquid tight manner. Filling and emptying takes place exclusively via one or two small bung openings (e.g. 2 inch opening) in the container lid which in turn are closeable by respective screw caps or bung plugs in a gas and liquid tight manner.

[0011] The lower container body does no longer directly participate in the sealing of the liquid fill goods and has essentially only a support function. As the container body no longer comes into contact with the liquid fill goods, it is eminently suitable for multiple use. The container body may be made of thermoplastic material (e.g. HD-PE) and manufactured by injection molding process, blow-molding process, or according to the rotational molding process.

[0012] With an embodiment of the invention, in the event of container drops, smaller deformations of tension ring and lid edge or container mouth do not immediately result in leaks with escape of liquid so long as the inner liner is not damaged. The lidded container is able to resist also - just like a bunged drum - significantly higher internal pressures in comparison to conventional lidded drums because the liquid-tight seal toward the container interior is realized no longer via a sealing ring placed on the outer circumference in relation to the container opening of great diameter but only on the significantly smaller bung closure (2 inch) or screw lid (e.g. 150 mm diameter) within the container lid. As a result of the significantly improved sealing behavior, higher-level UN approvals - also for hazardous liquid fill goods - can be acquired.

[0013] When liquid chemicals are filled hot (with process heat) for example, bunged drums of thermoplastic material have the drawback that the closed drums are subject to an internal pressure below atmospheric (vacuum formation), as the fill goods subsequently cool down, causing oftentimes lateral denting of the drum wall. This is especially critical when stacked bunged drums are involved with respect to drum drops as a result of toppling stacks. The plastic lidded drum according to embodiments of the invention with welded-in liner no longer encounters this adverse effect because the tension ring closure of drum lid and drum body is now no longer gas or liquid tight; rather the liner is able to easily contract following a hot-filling and compensate a vacuum formation, without having an impact on the shape and configuration and thus on the stacking capability of the outer drum body and the drum lid.

[0014] When both, liner and container lid, are made of plastic, the mutual welding or welding-on of the liner onto the edge of the container lid is preferred.

[0015] According to an advantageous design variation of the invention, the body,

the lid, and the welded-on liner are equally made of plastic material (HD-PE), wherein a bung opening arranged laterally in the central lid disk panel is fastened on the body by means of a steel clamping ring. This preferred design variation is - with respective UN approval - provided as replacement for normal plastic bunged drums which typically are used for the storage and transport of hazardous liquid fill goods. For multiple use of the cylindrical lidded drum body, such a packaging unit is more cost-efficient than a comparable bunged drum.

[0016] The lidded container according to the invention may, of course, also be used for solid, particulate, or slow-flowing, pasty fill goods, so long these goods, like liquids, can be filled with a fill pipe through the filling and emptying opening in the container lid and sucked out by means of a suction pipe out of the lidded container.

[0017] *[blank]*

[0018] According to another configuration of the invention, the liner has on its upper end a periphery which is formed in the outward direction and is welded or adhesively bonded, in a horizontal fastening region, into the U-shaped lid periphery which is located opposite the end surface of the container mouth. In an embodiment of the invention, the fastening region is aligned more in horizontal direction, wherein the liner edge reaches into the contact surface of the drum lid and is effectively clamped there additionally. This counteracts damaging tensile stress on the one hand and prevents the drum lid to "rattle" because the lidded drum according to the invention eliminates the need for conventional drum-lid-sized sealing rings in the lid edge and on the drum mouth.

[0019] The liner may normally be configured as cylindrical sheet-material sack and is produced from a thermoplastic material and may be provided with a woven-fabric insert for reinforcing purposes.

[0020] Advantageously, the liner, on its upper periphery, may be of thickened design in the fastening region and may have a wall thickness of at least 1 mm. To prevent the liner to twist in the drum body, the liner may be provided internally vertically running stiffening ribs in order to prevent it from rotating.

[0021] Exemplary embodiments of the invention will now be explained and described in greater detail with reference to the drawings, which schematically show in:

[0022] Figure 1 a perspective illustration of a lidded container according to the invention;

[0023] Figure 2 a cross section through the lidded container with inliner according to Fig. 1;

[0024] Figure 3 a cross section through the container body without inliner;

[0025] Figure 4 a top view of the container lid;

[0026] Figure 5 a cutaway view, on an enlarged scale, of a cross section of the lidded container.

[0027] Reference numeral 10 designates in Figure 1 a lidded container according to the invention in preferred embodiment in the shape of a solid cylindrical 220 liter lidded drum, which has a container body 12 with attached container lid 14 and tension ring closure 16. The container lid 14 has a central flat lid disk 18 formed therein with diametrically opposing bung openings and a U-shaped downwardly open lid edge 20 with an outer ring piece 22 and an inner ring piece 24 (Fig. 5). The central lid disk 18 is slightly elevated in relation to an outer flat, circumferential ring disk 32. Two diametrically opposing bung openings, which are

each closeable by a bung plug 38 in a gas and liquid tight manner, are arranged in the transition zone from outer ring disk 32 to the central lid disk 18 in bung troughs in such a recessed way that the surface of the screwed-in bung plug 38 extends in the closed state in vertical alignment with the surface of the attached tension ring 16 and the central lid disk 18.

[0028] A solidly formed wrap-around bottom roll ring or foot ring 40 is arranged at the lower edge of the container body 12 for improving stability as well as attaining higher standing capability and rolling capability of the filled drum, when tilted to an inclined position. The tension ring 16 spans with its upper leg the U-shaped lid edge 20 and with its lower leg a surface flange 34, which projects substantially radially outwards and is arranged on the outer wall of the container body 12 at the top at the container opening 36, with the tension ring pressing the container lid 14 onto the container opening 36.

[0029] Figure 2 shows a top view of the drum lid 14. Two opposing bung openings are closed in a gas and liquid tight manner with 2 inch bung plugs 38. Several stacking blocks 28 in the form of annular web pieces are provided on the outside in the flat ring disk 32 and on the inside directly behind the U-shaped lid edge. These stacking blocks 28 engage formfittingly in the engagement groove 30 arranged on the inside behind the bottom roll ring 40 (foot ring), when stacking like drums, and prevent a shift to the side of drums stacked on top of one another, e.g. when being shaken during transport.

[0030] Figure 3 shows a cross sectional view of the container body or a drum body 12 with upper filling opening 36, with upper surface flange 34 as tension ring counter support, and with bottom-side foot ring 40. Formed directly behind the foot ring 40 is the engagement groove 30 in the flat drum bottom plate.

[0031] Figure 4 shows the solid cylindrical lidded drum 10 as preferred embodiment of the invention with drum body 12, attached drum lid 14, and plastic inliner 26 welded onto the drum lid 14. The lidded drum has a capacity size of about 200 liters or 55 US gallons. With a height of 890 mm and an outer diameter of 585 mm, the lidded drum has almost the same dimensions as a corresponding steel drum and can be handled with the same drum gripper tools used for a steel drum.

[0032] The drum lid 14 is made of new plastic material (HD-PE virgin material) through an injection molding process. The inliner 26 is also made of new plastic material (HD-PE) and may be manufactured by an injection molding process, deep drawing process, or from joined film material. The inliner 26 may be composed as single-layered or multilayered cylindrical film bag and may have a wall thickness of 0.6 to 2 mm and a weight of about 1.2 to 3.4 kg. A multilayered inliner is preferably provided with a barrier layer (permeation barrier) to prevent migration of hydrocarbons, carbon dioxide, or oxygen. The gas and liquid tight inliner 26 may further be provided with a fabric inset for reinforcement and stiffening ribs extending in vertical direction to secure against twisting within the drum body, when a filled drum is slantingly rolled. The drum body 12 may be manufactured by an injection molding process or blow molding process and may be made of new plastic material (HD-PE) or recycled plastic material. The weight of the drum body may range from approx. 5.0 to 9.5 kg at a wall thickness of approx. 2.5 to 5 mm. Multiple use of the drum body advantageously permits a reduction in packaging costs, consumption of new material and thus material costs, and decreases the amount of waste material of used packaging containers.

[0033] The area "A" encircled in Fig. 4 at the top left-hand side is illustrated in Figure 5 on an enlarged scale by way of a partial cross section. It can be seen that the inner ring piece 24 of the U-shaped lid edge 20 is prolonged such that a piece thereof extends into the container body opening 36. The "dipping depth" of the ring piece 24 (= height of the ring piece) may range between 10 and 60 mm. According to

a preferred embodiment, the smooth outer side of the annular web 24 has as fastening region 42 for welding or gluing the inliner a height of approx. 35 mm (measured on the inside from the ring disk 32), to which the inliner is welded or glued with the inner side of its upper rim area.

[0034] According to another design variant, the inliner 26 is welded or glued with the outer side of its upper rim area to the inner side of the annular web 24. Welding or gluing is implemented along at least one circumferential continuous line. However, also two or more circumferential welding lines may be provided. When providing several welding lines, the lowermost and the uppermost welding lines are preferably configured linearly straight continuous, while the or one of the middle welding lines has a zigzag or wavy shape so that a wider region is used at the upper rim of the inliner for securement so that, i.a., dispersion of tensile forces is improved. In particular, when the inliner is glued on or glued in, a broader circumferential, i.e. flat gluing zone can be realized. Such a gluing zone may have a height of about 5 mm to 40 mm, preferably about 15 mm.

[0035] The welding zone may extend across a height of 10 mm to 50 mm, preferably about 20 mm, when at least two circumferential welding lines are welded. As a consequence of a broader attachment zone of the inliner, locally excessive tensile stress can be better dispersed across a greater surface area and absorbed so that the inliner is prevented from being overstretched and the welded connection between inliner and lid is prevented from cracking open.

[0036] Figure 6 shows once more a detailed view of the container mouth and the container lid configuration. As the flat ring disk 32, arranged directly adjacent behind the U-shaped lid edge, is deeper by approx. 15 to 20 mm in relation to the upper end edge 32 of the U-shaped lid edge, a circumferential engagement groove is established for the use and handling of a filled lidded container by means of drum gripper tools (parrot's beak) as used also for conventional steel drums.

[0037] The inliner includes in the fastening zone 42 preferably a thickened edge for improving welding or gluing. The wall thickness may be twice as thick there as the normal wall thickness of the inliner (about 0.5 to 2 mm). The inliner may be designed in various ways. According to one design variant, the inliner 26 may be made of a metal foil or a liquid-tight plastic-coated fabric sheet through which metal threads are drawn. When used in the food industry, it may, e.g., also be provided to make the inliner 26 of a multilayered plastic film and a barrier layer against permeation (penetration) of hydrocarbons.

[0038] The welding or gluing in vertical direction, as described further above, can be combined with the inliner securement in horizontal direction in the U-shaped lid edge so that a broader fastening region and a clamping in the contact area of the U-shaped lid edge can be effected on the upper drum mouth edge in the tension zone of the tension ring closure.

[0039] The lidded drum according to the invention permits the complete elimination of a wrap-around sealing ring for placement in the U-shaped lid edge 20 because the container lid 14 does not have to be sealed in a gas and liquid tight manner on the upper mouth edge of the container opening, when the tension ring is closed, since the drum lid with the welded-on inliner forms already an absolutely liquid-tight unit. While conventional liquid-filled lidded drums normally become already leaky when encountering container drops from drop heights of 1.2 m, the lidded container according to the invention remains absolutely liquid-tight, even when dropped from greater heights so long as the tension ring does not completely pop off.

[0040] In accordance with the invention, a liquid-tight lidded drum is thus created in a simple manner and has performance data almost on par with a closed single-piece bunged drum. The tightness of the lidded drum according to the invention is significantly increased when subjected to container drops and internal

pressure stress so that it is best suited for use of liquid fill goods and can even be approved for certain hazardous liquid fill goods.

[0041] The drum body which now fulfills solely a purely protective function and does not come into contact with the fill goods and thus is free from any adhering fill goods residues after discharge of the fill goods, can be used again many times in a manner that is gentle to the material and environment.

List of Reference Signs

- 10** lidded drum
- 12** container body
- 14** container lid
- 16** tension ring
- 18** central flat lid disk
- 20** U-shaped lid edge
- 22** outer ring piece (20) (= outer lid flange)
- 24** inner ring piece (20) (= inner lid flange)
- 26** inliner (= cylindrical film bag)
- 28** lid web (14) (= stacking block)
- 30** engagement groove behind foot ring (40)
- 32** ring disk (14)
- 34** surface flange (12)
- 36** container opening (12)
- 38** bung plug
- 40** foot ring (12)
- 42** fastening zone

THE CLAIMS DEFINING THE INVENTION ARE AS FOLLOWS:-

1. Lidded container for storing and transporting hazardous liquid contents, having;
an outer container body,
an upper container lid, and
a thin-walled liner inserted in the container,

wherein the container lid can be fixed on an appropriately formed flange periphery on the upper container opening of the container body by means of a U-shaped clamping ring closure or, without a clamping ring as a snap-fitting lid, by means of a snap fitting closure or, as a screw-fitting lid, by means of a screw closure,

wherein the container lid consists of thermoplastic material and is produced by injection moulding or blow moulding and has at least one relatively small lid opening, which can be closed in a gas-tight and liquid-tight manner by means of a closure lid and through which the liquid contents can be introduced and removed, and

wherein the thin-walled liner is welded or adhesively bonded in a gas-tight and liquid-tight manner to the outer circumferential region of the underside of the container lid wherein the container lid and the liner fixed thereon form a gas-tight and liquid-tight hollow-body unit, wherein the container lid has a U-shaped periphery which is open in the downward direction and has a vertical outer lid flange and a vertical inner flange, wherein the liner is welded or adhesively bonded, in a vertical fastening region to the outside of the inner lid flange.

2. Lidded container according to claim 1, wherein the container body, container lid and welded-on liner all consist of thermoplastic material (HDPE), wherein the container lid with a bung opening arranged laterally in the central lid disc panel, is fastened on the container body by means of a steel clamping ring.

3. Lidded container according to claim 1 or 2, wherein the inner lid flange is of extended design and thus provides a relatively wide fastening zone for fixing the liner.

4. Lidded container according to any one of claims 1 to 3, wherein the liner, at its upper end, has a periphery which is formed in the outward direction and is welded or adhesively bonded, in a horizontal fastening region, into the U-shaped lid periphery, which is located opposite the end surface of the container mouth.

5. Lidded container according to any one of claims 1 to 4, wherein the liner is designed as a cylindrical sheet-material sack and is produced from thermoplastic material and is provided with a woven-fabric insert for reinforcing purposes.

6. Lidded container according to any one of claims 1 to 5, wherein the liner, on its upper periphery, is of thickened design in the fastening region and has a wall thickness of at least 1 mm.

7. Lidded container according to any one of claims 1 to 6, wherein the liner is provided internally with vertically running stiffening ribs in order to prevent it from rotating.

8. Lidded container according to any one of claims 1 to 7, wherein the liner consists of a metal foil or a liquid-tight plastic-coated woven-fabric sheet material which has metal filaments running through it.

9. Lidded container according to any one of claims 1 to 8, wherein the liner consists of a multilayered plastics sheet material and has a barrier layer to counter the permeation of hydrocarbons.

10. Lidded container substantially as hereinbefore described with reference to the accompanying drawings.

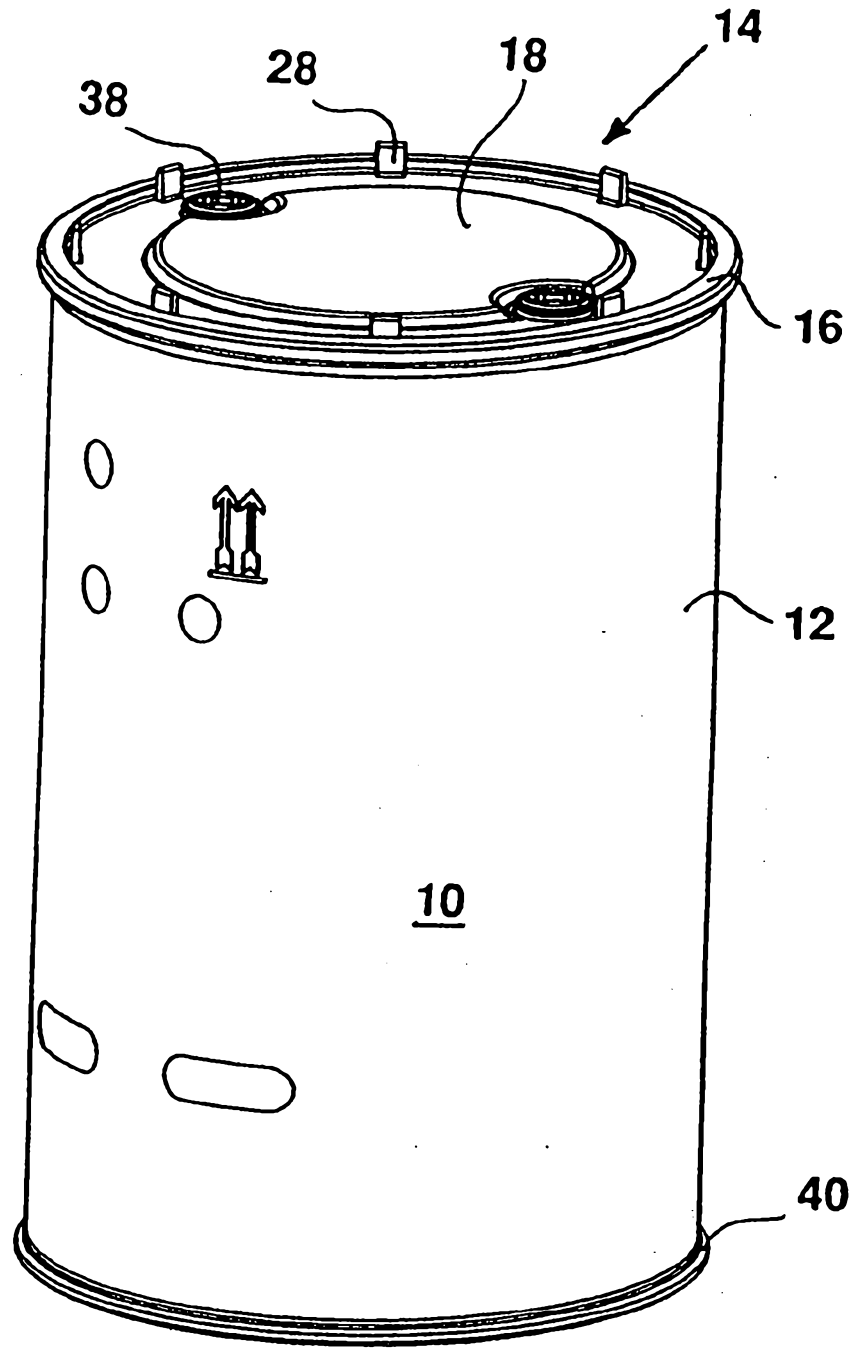

FIG. 1

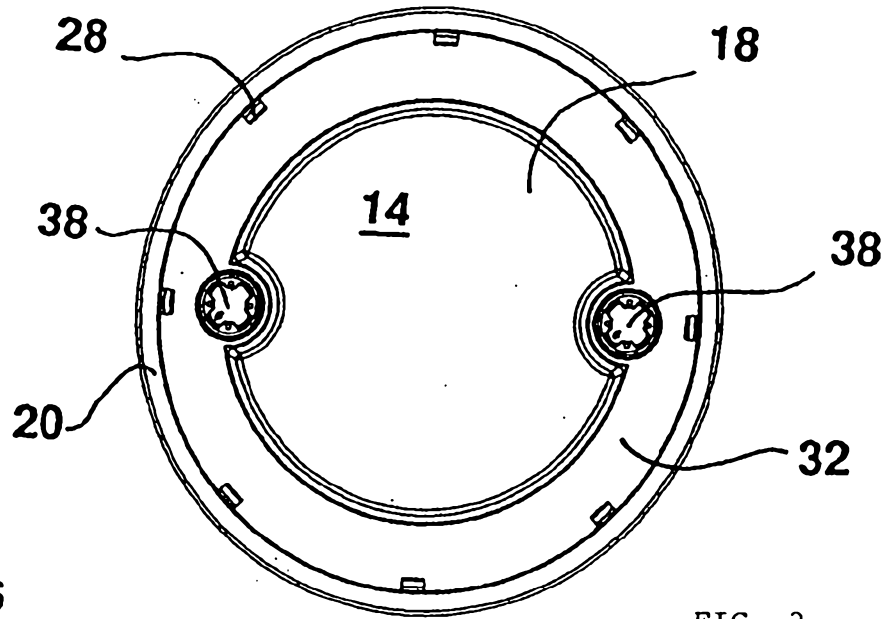

FIG. 2

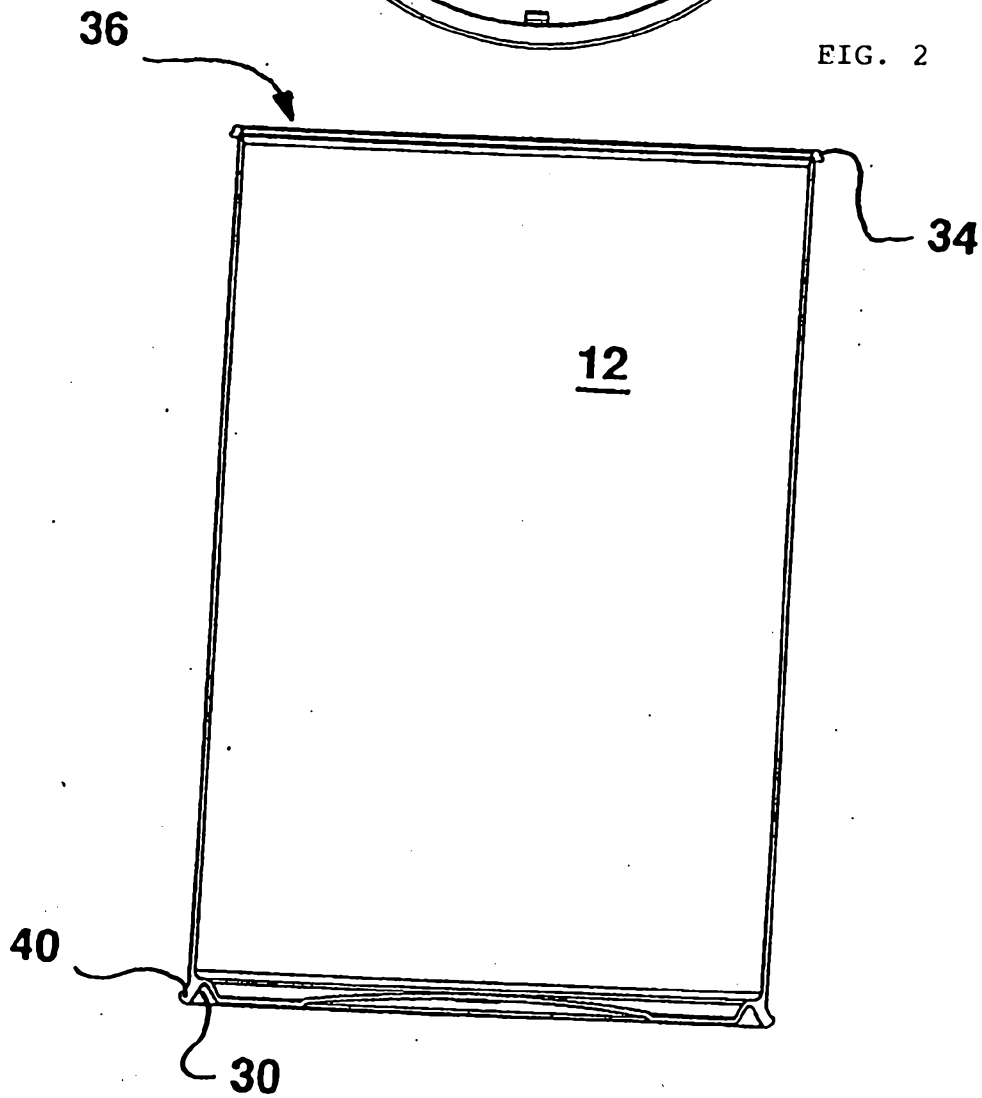
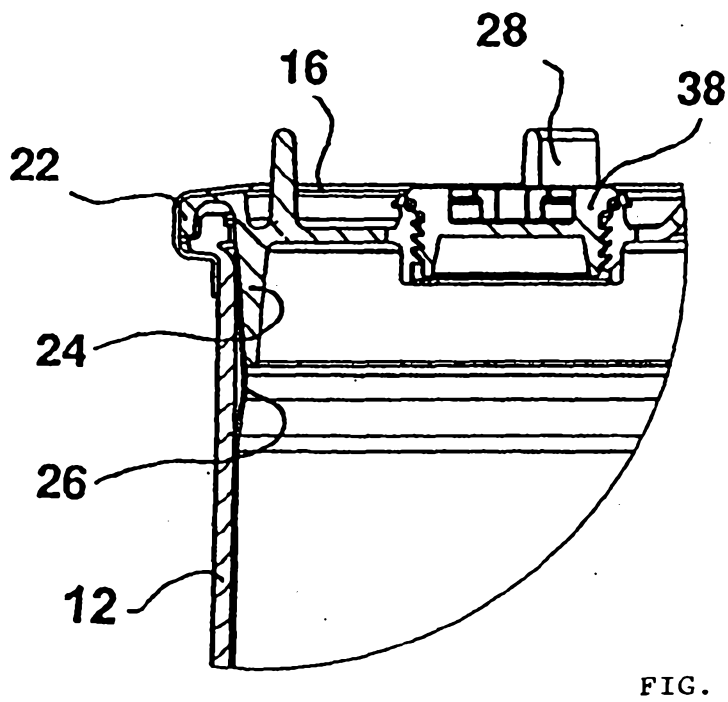
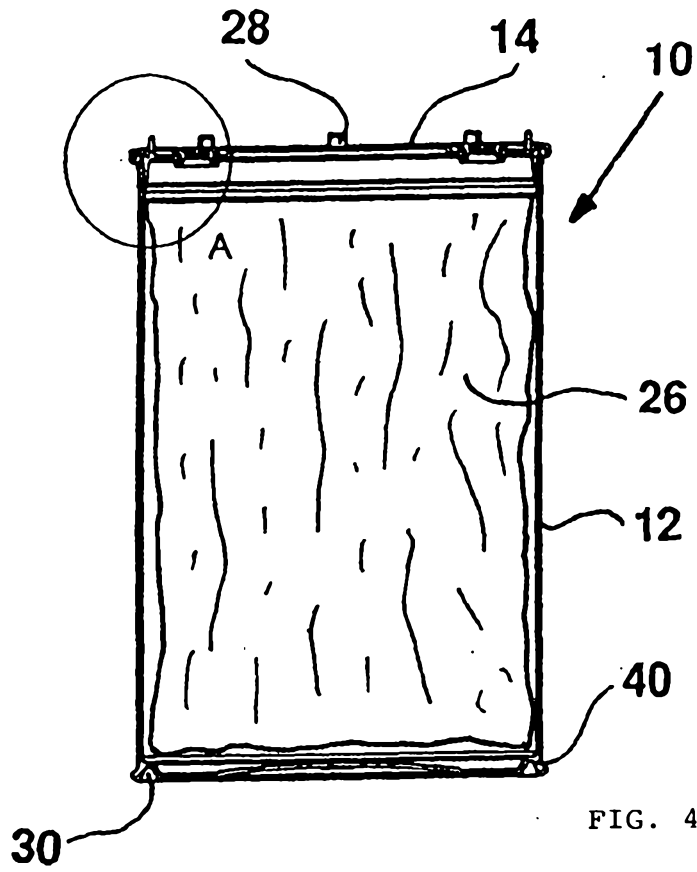

FIG. 3

Substitute sheet (Rule 26)



Substitute sheet (Rule 26)

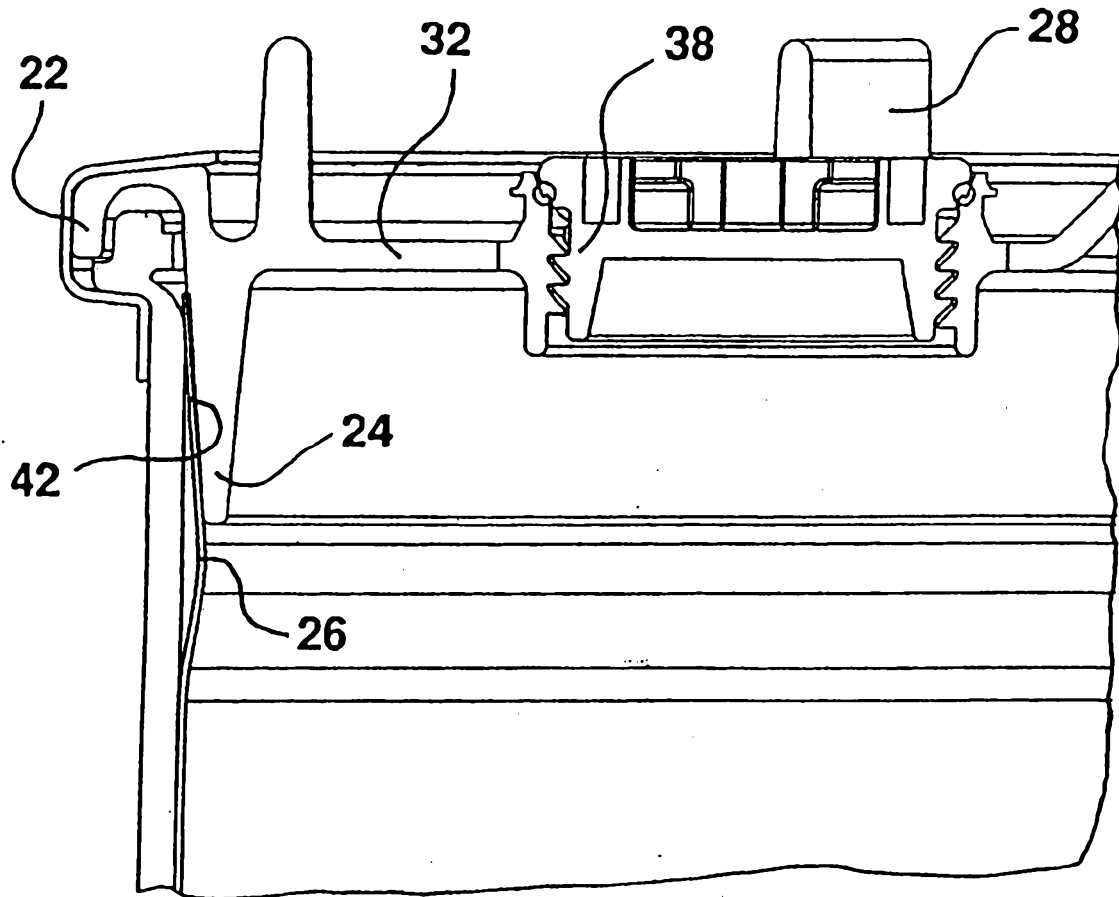

FIG. 6