

(19) World Intellectual Property
Organization
International Bureau



(43) International Publication Date
24 February 2005 (24.02.2005)

PCT

(10) International Publication Number
WO 2005/016699 A1

(51) International Patent Classification⁷: **B60R 13/02**

(21) International Application Number:
PCT/US2004/026322

(22) International Filing Date: 11 August 2004 (11.08.2004)

(25) Filing Language: English

(26) Publication Language: English

(30) Priority Data:
60/494,491 12 August 2003 (12.08.2003) US

(71) Applicant (for all designated States except US): **INTIER AUTOMOTIVE INC.** [US/US]; 600 Wilshire Drive, Troy, MI 48084 (US).

(72) Inventors; and

(75) Inventors/Applicants (for US only): **ASBURY, James, Daniel** [US/US]; 30080 Cobblestone Court, New Hudson, MI 48165 (US). **KOCHER, Larry** [CA/US]; 3800 Napier Road, Canton, MI 48187 (US). **FORGETTE, Paul, Alan** [US/US]; 24149 Mahogany, Brownstone, MI 48134 (US).

(74) Agents: **RASHID, Peter, J.** et al.; Honigman Miller Schwartz and Cohn L.L.P., Suite 225, 32270 Telegraph Road, Bingham Farms, MI 48025 (US).

(81) Designated States (unless otherwise indicated, for every kind of national protection available): AE, AG, AL, AM, AT, AU, AZ, BA, BB, BG, BR, BW, BY, BZ, CA, CH, CN, CO, CR, CU, CZ, DE, DK, DM, DZ, EC, EE, EG, ES, FI, GB, GD, GE, GH, GM, HR, HU, ID, IL, IN, IS, JP, KE, KG, KP, KR, KZ, LC, LK, LR, LS, LT, LU, LV, MA, MD, MG, MK, MN, MW, MX, MZ, NA, NI, NO, NZ, OM, PG, PH, PL, PT, RO, RU, SC, SD, SE, SG, SK, SL, SY, TJ, TM, TN, TR, TT, TZ, UA, UG, US, UZ, VC, VN, YU, ZA, ZM, ZW.

(84) Designated States (unless otherwise indicated, for every kind of regional protection available): ARIPO (BW, GH, GM, KE, LS, MW, MZ, NA, SD, SL, SZ, TZ, UG, ZM, ZW), Eurasian (AM, AZ, BY, KG, KZ, MD, RU, TJ, TM), European (AT, BE, BG, CH, CY, CZ, DE, DK, EE, ES, FI, FR, GB, GR, HU, IE, IT, LU, MC, NL, PL, PT, RO, SE, SI, SK, TR), OAPI (BF, BJ, CF, CG, CI, CM, GA, GN, GQ, GW, ML, MR, NE, SN, TD, TG).

Declarations under Rule 4.17:

— as to applicant's entitlement to apply for and be granted a patent (Rule 4.17(ii)) for the following designations AE, AG, AL, AM, AT, AU, AZ, BA, BB, BG, BR, BW, BY, BZ, CA, CH, CN, CO, CR, CU, CZ, DE, DK, DM, DZ, EC, EE, EG, ES, FI, GB, GD, GE, GH, GM, HR, HU, ID, IL, IN, IS, JP, KE, KG, KP, KR, KZ, LC, LK, LR, LS, LT, LU, LV, MA, MD, MG, MK, MN, MW, MX, MZ, NA, NI, NO, NZ, OM, PG, PH, PL, PT, RO, RU, SC, SD, SE, SG, SK, SL, SY, TJ, TM, TN, TR, TT, TZ, UA, UG, UZ, VC, VN, YU, ZA, ZM,

[Continued on next page]

(54) Title: VEHICLE PANEL WITH METALIZED FILM

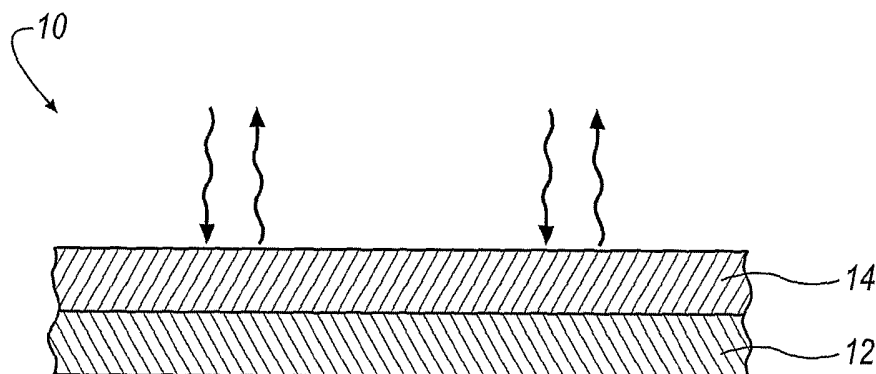

(57) Abstract: A vehicle panel (10) includes a core layer (12) and a layer of metalized film (14) bonded to the core layer (12). In one embodiment, the core layer (12) is made of a material with heat absorption or insulation properties. The layer of metalized film (14) is made of a material having heat reflective properties that can be bonded to the core layer (12). Alternatively, a compatible bonding agent can be applied to the core layer, the metalized film, or both. To form the vehicle panel (10), the layer metalized film (14) is positioned on one half of a mold tool and the core layer (12) is positioned on the other half of the mold tool. Heat is applied to the core layer (12) and the mold tool is closed such that the heat from the core layer (12) causes the metalized film (14) to be in a formable state and bonds to the core layer (12).

WO 2005/016699 A1



ZW, ARIPO patent (BW, GH, GM, KE, LS, MW, MZ, NA, SD, SL, SZ, TZ, UG, ZM, ZW), Eurasian patent (AM, AZ, BY, KG, KZ, MD, RU, TJ, TM), European patent (AT, BE, BG, CH, CY, CZ, DE, DK, EE, ES, FI, FR, GB, GR, HU, IE, IT, LU, MC, NL, PL, PT, RO, SE, SI, SK, TR), OAPI patent (BF, BJ, CF, CG, CI, CM, GA, GN, GQ, GW, ML, MR, NE, SN, TD, TG)

- as to the applicant's entitlement to claim the priority of the earlier application (Rule 4.17(iii)) for the following designations AE, AG, AL, AM, AT, AU, AZ, BA, BB, BG, BR, BW, BY, BZ, CA, CH, CN, CO, CR, CU, CZ, DE, DK, DM, DZ, EC, EE, EG, ES, FI, GB, GD, GE, GH, GM, HR, HU, ID, IL, IN, IS, JP, KE, KG, KP, KR, KZ, LC, LK, LR, LS, LT, LU, LV, MA, MD, MG, MK, MN, MW, MX, MZ, NA, NI, NO, NZ, OM, PG, PH, PL, PT, RO, RU, SC, SD, SE, SG, SK, SL, SY, TJ, TM, TN, TR, TT, TZ, UA, UG, UZ, VC, VN, YU, ZA, ZM,

ZW, ARIPO patent (BW, GH, GM, KE, LS, MW, MZ, NA, SD, SL, SZ, TZ, UG, ZM, ZW), Eurasian patent (AM, AZ, BY, KG, KZ, MD, RU, TJ, TM), European patent (AT, BE, BG, CH, CY, CZ, DE, DK, EE, ES, FI, FR, GB, GR, HU, IE, IT, LU, MC, NL, PL, PT, RO, SE, SI, SK, TR), OAPI patent (BF, BJ, CF, CG, CI, CM, GA, GN, GQ, GW, ML, MR, NE, SN, TD, TG)

- of inventorship (Rule 4.17(iv)) for US only

Published:

- with international search report

For two-letter codes and other abbreviations, refer to the "Guidance Notes on Codes and Abbreviations" appearing at the beginning of each regular issue of the PCT Gazette.

VEHICLE PANEL WITH METALIZED FILM

BACKGROUND OF THE INVENTION

Field of the Invention

[0001] The present invention relates in general to a vehicle panel structure, and in particular to a vehicle panel structure that includes a core layer and a layer of metalized film to provide the vehicle panel structure with improved thermal properties.

Description of the Related Art

[0002] Typically, a vehicle panel, such as a headliner, includes an air gap between the vehicle roof and the headliner to provide a thermal barrier between the vehicle roof and the headliner. Unfortunately, one problem associated with the necessity of this air gap is that the overall distance between the vehicle roof and the headliner is increased.

SUMMARY OF THE INVENTION

[0003] The inventor of the present invention has recognized these and other problems associated with conventional vehicle panels, and have developed a vehicle panel comprising a core layer and a layer of metalized film. The layer of metalized film eliminates the need for an air gap between two layers of material, such as a vehicle roof and a headliner, thereby minimizing the thickness of the vehicle panel while improving thermal performance of the vehicle panel structure. Thus, the vehicle panel of the invention comprises a core layer, and a layer of metalized film bonded to the core layer. Preferably, the material for the core layer is compatible with the material for metalized film such that the metalized film is bonded to the core layer with the application of heat. Alternately, a bonding agent may be applied to either the core layer or the metalized film that is compatible to the materials used for the core layer and the metalized film to form the appropriate bond between the core layer and the metalized film upon the application of heat.

[0004] A method of manufacturing the vehicle panel comprises the steps of positioning the core layer on a surface of a mold half, and positioning the metalized film on the surface of the other mold half. After placing the core layer and the metalized film, heat is applied to either the core layer or the metalized film by heating the core layer or heating the mold half with the metalized film for a predetermined temperature. Then, the mold halves are closed to press the core layer against the metalized film for a predetermined period of time. As the metalized film is heated, the metalized film becomes formable and is bonded to the surface of the core layer to form the vehicle panel. The mold halves are then opened and the vehicle panel is removed.

BRIEF DESCRIPTION OF THE DRAWINGS

[0005] In the drawings:

[0006] The Figure shows a cross-sectional view of a vehicle panel structure including a core layer and a layer of metalized film according to an embodiment of the invention.

DESCRIPTION OF THE PREFERRED EMBODIMENT

[0007] Referring now to the Figure, a vehicle panel 10 is shown according to an embodiment of the invention. The vehicle panel 10 includes a core layer 12 and a layer of metalized film 14 bonded to the core layer 12. Optionally, the vehicle panel 10 may include a second layer of metalized film or suitable material (not shown), such as a fabric, bonded or otherwise attached to the opposite surface of the core layer 12.

[0008] The core layer 12 may be made of any desirable material. Preferably, the core layer 12 is comprised of any suitable material having insulating properties. For example, the core layer 12 may comprise a foam material, such as polypropylene or the like, and have a density and thickness that may vary depending on the design requirements.

[0009] The metalized film 14 may be made of any type of material that is capable of reflecting heat, such as polyethylene terephthalate (PET) or the like. Preferably, the material used for the metalized film 14 is compatible with the material used for the

core layer 12 such that the metalized film 14 can form a bond with the core layer 12. One suitable material for the metalized film 14 is commercially available under the trade name METALLYTE™ MET available from ExxonMobil Chemical. The metalized film 14 contains a polymer material, such as polypropylene or the like, that is compatible with the material for the core layer 12. In addition, the metalized film 14 is coated with a metallic material, such as aluminum or the like, that has excellent heat reflection properties.

[0010] Ideally, the metalized film 14 is bonded to the outer surface of the core layer 12 that is nearest the source of heat to be reflected by the vehicle panel 10. If necessary, a second layer of metalized film 14 or other suitable material can be applied to an opposite surface of the core layer 12 in situations where the source of heat is emanating from opposite sides of the core layer 12. However, in most situations, the core layer 12 is exposed to only one heat source, and therefore only one layer of metalized film 12 is required for adequate heat reflection.

[0011] For example, the core layer 12 with metalized film 14 can be used as a headliner of a vehicle. In this example, the source of heat (indicated by the arrows in the Figure) would be the vehicle roof so the metalized film 14 would be applied to only one surface of the core layer 12 that is nearest the vehicle roof. It has been found that when the core layer 12 with metalized film 14 positioned nearest the vehicle roof is used as a headliner that the headliner exhibits superior heat reflection and heat absorption properties, as compared to conventional headliners that require the air gap between the headliner and the vehicle roof for insulation. Thus, the vehicle panel 10 comprising the core layer 12 with metalized film 14 eliminates the need of an air gap. As a result, the vehicle panel 10 when used as a headliner requires less real estate (i.e. has less thickness) as compared to conventional headliners with an air gap.

[0012] A method for manufacturing the vehicle panel 10 will now be described. Typically, a mold tool (not shown) includes two mold halves. It is understood that the mold halves have complimentary shapes in the shape of the vehicle panel to be formed. The core layer 12 is positioned in one mold half using conventional means. The metalized film 14 is positioned on the other mold half using conventional means, such as tenured, pinned, clamped, vacuumed, or the like, in a manner known in the

art. The core layer 12 is then heated to a predetermined temperature, such as approximately 400 degrees Fahrenheit to cause the core layer 12 to be in a somewhat molten state. The mold halves are then closed together to press the core layer 12 in engagement with the metalized film 14 for a predetermined period of time, such as approximately 30 seconds. When the mold halves are pressed together, some of the heat from the core layer 12 is transferred to the metalized film 14 such that the metalized film 14 becomes formable and molded to the shape of the core layer 12. The source of heat being transferred to the metalized film 14 can be from other sources of heat, such as the mold tool itself, rather than from the core layer 12.

[0013] It should be noted that the topography of the core layer 12 and the vehicle panel 10 is non-flat. In these cases, it has been found that the metalized film 14 may become wrinkled in locations where the core layer 12 may have a non-flat topography. However, the metalized film 14 having a substantially flat surface before being placed in the mold half still provides an acceptable bond to the entire surface of the core layer 12 because the metalized film 14 is placed in the mold half with enough tolerance to substantially conform to the topography of the core layer 12 and the vehicle panel 10 being formed.

[0014] While the invention has been specifically described in connection with certain specific embodiments thereof, it is to be understood that this is by way of illustration and not of limitation, and the scope of the appended claims should be construed as broadly as the prior art will permit.

CLAIMS

What is claimed is:

1. A vehicle panel (10), comprising:
a core layer (12), and
a layer of metalized film (14) bonded to said core layer (12).
2. The vehicle panel of Claim 1, wherein said layer of metalized film (14) is made of a material that is compatible with said core layer (12).
3. The vehicle panel of Claim 2, wherein said layer of metalized film (14) comprises polyethylene terephthalate (PET).
4. The vehicle panel of Claim 1, wherein said core layer (12) is made of an insulating material.
5. The vehicle panel of Claim 4, wherein said core layer (12) comprises polypropylene material.
6. The vehicle panel of Claim 1, wherein said vehicle panel (10) comprises a headliner.
7. A method of manufacturing a vehicle panel (10), comprising the steps of:
positioning a core layer (12) on a first mold half of a mold tool;
positioning a metalized film (14) on a second mold half of the mold tool; and
closing the first and second mold halves and applying heat to the core layer (12) such that the heat from core layer (12) is transferred to the metalized film (14), whereby the metalized film (14) becomes formable and bonds to the core layer (12).

1/1

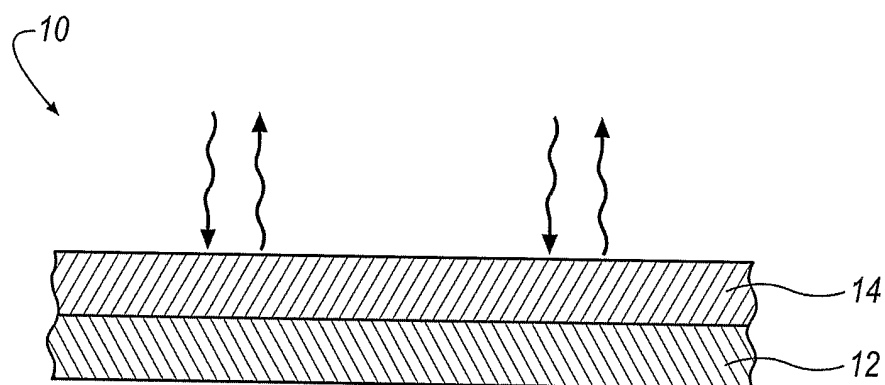

FIG. 1

INTERNATIONAL SEARCH REPORT

International Application No
PCT/US2004/026322

A. CLASSIFICATION OF SUBJECT MATTER
IPC 7 B60R13/02

According to International Patent Classification (IPC) or to both national classification and IPC

B. FIELDS SEARCHED
Minimum documentation searched (classification system followed by classification symbols)
IPC 7 B60R B32B B29C

Documentation searched other than minimum documentation to the extent that such documents are included in the fields searched

Electronic data base consulted during the international search (name of data base and, where practical, search terms used)
EPO-Internal, WPI Data, PAJ

C. DOCUMENTS CONSIDERED TO BE RELEVANT

Category *	Citation of document, with indication, where appropriate, of the relevant passages	Relevant to claim No.
X	PATENT ABSTRACTS OF JAPAN vol. 2003, no. 11, 5 November 2003 (2003-11-05) -& JP 2003 212056 A (NISSAN MOTOR CO LTD), 30 July 2003 (2003-07-30) abstract	1
X	EP 0 995 667 A (MERITOR AUTOMOTIVE GMBH) 26 April 2000 (2000-04-26) column 14, line 25 - line 31	1,6
X	US 5 016 936 A (GOODRICH DAVID) 21 May 1991 (1991-05-21) the whole document	1,4,6
X	DE 299 18 214 U (ALUSUISSE KAPA GMBH) 13 January 2000 (2000-01-13) the whole document	1,3,6
----- -/--		

Further documents are listed in the continuation of box C. Patent family members are listed in annex.

* Special categories of cited documents:

- *A* document defining the general state of the art which is not considered to be of particular relevance
- *E* earlier document but published on or after the international filing date
- *L* document which may throw doubts on priority claim(s) or which is cited to establish the publication date of another citation or other special reason (as specified)
- *O* document referring to an oral disclosure, use, exhibition or other means
- *P* document published prior to the international filing date but later than the priority date claimed
- *T* later document published after the international filing date or priority date and not in conflict with the application but cited to understand the principle or theory underlying the invention
- *X* document of particular relevance; the claimed invention cannot be considered novel or cannot be considered to involve an inventive step when the document is taken alone
- *Y* document of particular relevance; the claimed invention cannot be considered to involve an inventive step when the document is combined with one or more other such documents, such combination being obvious to a person skilled in the art.
- *&* document member of the same patent family

Date of the actual completion of the international search 17 November 2004	Date of mailing of the international search report 30/11/2004
--	---

Name and mailing address of the ISA European Patent Office, P.B. 5818 Patentlaan 2 NL - 2280 HV Rijswijk Tel. (+31-70) 340-2040, Tx. 31 651 epo nl, Fax: (+31-70) 340-3016	Authorized officer Busuiocescu, B
--	---

INTERNATIONAL SEARCH REPORT

International Application No
PCT/US2004/026322

C.(Continuation) DOCUMENTS CONSIDERED TO BE RELEVANT

Category *	Citation of document, with indication, where appropriate, of the relevant passages	Relevant to claim No.
X	US 4 068 034 A (SEGAWA MASAHIRO ET AL) 10 January 1978 (1978-01-10)	1,3-6
Y	the whole document	2,7
Y	----- EP 0 412 346 A (GEN ELECTRIC) 13 February 1991 (1991-02-13) column 9, line 1 - line 56	2,7
A	----- EP 0 640 467 A (GEN ELECTRIC) 1 March 1995 (1995-03-01) -----	

INTERNATIONAL SEARCH REPORT

International Application No
PCT/US2004/026322

Patent document cited in search report		Publication date	Patent family member(s)	Publication date
JP 2003212056	A	30-07-2003	NONE	
EP 0995667	A	26-04-2000	AT 228455 T BR 9905100 A DE 59903532 D1 EP 1193163 A2 EP 0995667 A1 ES 2188079 T3 JP 2000128021 A KR 2000029149 A US 6499797 B1	15-12-2002 29-08-2000 09-01-2003 03-04-2002 26-04-2000 16-06-2003 09-05-2000 25-05-2000 31-12-2002
US 5016936	A	21-05-1991	NONE	
DE 29918214	U	13-01-2000	DE 29918214 U1	13-01-2000
US 4068034	A	10-01-1978	NONE	
EP 0412346	A	13-02-1991	US 4983247 A DE 69018894 D1 EP 0412346 A2 JP 1904752 C JP 3099812 A JP 6028868 B	08-01-1991 01-06-1995 13-02-1991 08-02-1995 25-04-1991 20-04-1994
EP 0640467	A	01-03-1995	US 5499441 A EP 0640467 A1 JP 7164462 A	19-03-1996 01-03-1995 27-06-1995