



(11) **EP 3 385 488 B1**

(12) **EUROPEAN PATENT SPECIFICATION**

(45) Date of publication and mention of the grant of the patent:
19.06.2019 Bulletin 2019/25

(51) Int Cl.:
E06B 3/82 (2006.01) E06B 3/72 (2006.01)

(21) Application number: **17207030.2**

(22) Date of filing: **13.12.2017**

(54) **DOOR LEAF WITH PANEL AND PANEL KIT FOR SUCH A DOOR LEAF**
TÜRBLATT MIT PANEEL UND PANEELSATZ FÜR SOLCH EIN TÜRBLATT
VANTAIL DE PORTE AVEC PANNEAU ET KIT DE PANNEAU POUR UN TEL VANTAIL DE PORTE

(84) Designated Contracting States:
AL AT BE BG CH CY CZ DE DK EE ES FI FR GB GR HR HU IE IS IT LI LT LU LV MC MK MT NL NO PL PT RO RS SE SI SK SM TR

(30) Priority: **06.04.2017 BE 201705243**

(43) Date of publication of application:
10.10.2018 Bulletin 2018/41

(73) Proprietor: **HARINCK, naamloze vennootschap**
8710 Wielsbeke (BE)

(72) Inventor: **DE MUNSTER, Franck**
8710 Wielsbeke (BE)

(74) Representative: **Donné, Eddy et al**
Bureau M.F.J. Bockstael nv.
Arenbergstraat 13
2000 Antwerpen (BE)

(56) References cited:
EP-A1- 3 045 650 FR-A1- 2 927 113

EP 3 385 488 B1

Note: Within nine months of the publication of the mention of the grant of the European patent in the European Patent Bulletin, any person may give notice to the European Patent Office of opposition to that patent, in accordance with the Implementing Regulations. Notice of opposition shall not be deemed to have been filed until the opposition fee has been paid. (Art. 99(1) European Patent Convention).

Description

[0001] The present invention concerns a door leaf with panel, more in particular the leaf of a door intended to be mounted hingeably in a frame of the door.

[0002] In particular the invention concerns a type of door leaf including a frame and a door panel with a front sheet and a rear sheet and a possible intermediate sheet between both, whereby the frame is made of traditional profiles with a front wall and rear wall, on the front and back of the frame respectively, an inside wall and an outside wall, on the inner edge and the outer edge of the frame respectively, and on the inside wall of the profiles a lip facing inwards to form a rabbet.

[0003] Adhering the front sheet against the front of the frame is known, with the front of the frame being at least partially covered.

[0004] A disadvantage occurring with adhered front sheets is the large temperature differences between the front sheet and the rear sheet, for example when the front sheet is exposed to full sunlight and the rear sheet is in the shade.

[0005] In such a case there is the risk of the front sheet expanding and warping to the outside, which is obviously undesirable for the appearance of the door.

[0006] Moreover, this causes undesired stresses in the door leaf and in the door frame, which can for example cause the lock built into the frame to no longer work properly.

[0007] Another disadvantage is that adhering the front sheet to the frame on assembly is relatively labour-intensive and must take place in controlled conditions.

[0008] Yet another disadvantage is that the lateral movement of the front sheet on the frame, for example to align the front sheet with the frame or the lock, becomes very difficult with the hardening of the adhesive.

[0009] An additional disadvantage is that an adhered front sheet can no longer be removed without causing damage to the exterior door.

[0010] In WO 2016/112437 from the same applicant another technique is known to fasten the front sheet to the frame using clamping means formed by one or more clamps along the circumference of the frame with a base element that is fastened to the front sheet with on top a clamp arm that hooks behind the abovementioned lip and that can be tightened on the base element towards the front sheet by screws.

[0011] Although such a technique offers indisputable advantages, there is the problem here that with extreme temperature differences the front sheet can warp, although to a lesser extent than in the case of adhered front sheets.

[0012] Screwing the clamping means during assembly is relatively labour-intensive, whereby the screws also have to be accurately fastened with a tightness that is not too low to achieve sufficient permanent attachment, but is also not too high to prevent damage.

[0013] The purpose of the present invention is to pro-

vide a solution to one or more of the aforementioned and other disadvantages.

[0014] To this end, the invention concerns a door leaf of the type as described above, but whereby the front sheet is fastened on the frame by means of at least one or more first coupling parts that are fastened on the front sheet, and by one or more cooperating second coupling parts fastened on the rear sheet or on the intermediate sheet, whereby the first coupling parts and the second coupling parts magnetically attract each other, in such a way that the magnetic cooperation of the coupling parts causes the rear sheet or the intermediate sheet to hook behind the abovementioned lip and is pulled against it in such a way that they allow movement between the coupling parts in a direction parallel to the surface of the front sheet.

[0015] An advantage is that the fastening of the front sheet is very simple and can be carried out very quickly by simply for example:

- either, first positioning and fixing the rear sheet, or the intermediate sheet if provided, in the rabbet of the frame, for example by means of a glazing bead as known, and then placing the front sheet against the front wall of the frame to magnetically couple the front sheet with the rear sheet or intermediate sheet;
- or, first placing the frame with its front wall on the front sheet and then positioning the rear sheet or the intermediate sheet, if provided, in the rabbet of the frame to magnetically couple the coupling parts to each other with clamping of the abovementioned lip of the frame between the front sheet and the rear sheet or intermediate sheet.

[0016] Then at this stage of assembly the front sheet can be, if required, further moved for correct alignment with the frame.

[0017] This is possible because magnets have a significant attractive force to each other in a direction perpendicular to their contact surface, but they only offer small resistance against a lateral movement in the direction of the contact surface.

[0018] For the same reason the magnetic coupling will offer little resistance to lateral expansion of the front sheet, for example because the sun is shining on it.

[0019] As a result, the front sheet, the frame or the profiles of the frame will be prevented from warping due to expansion as will the difficult working of the door lock.

[0020] Another advantage of the invention is that, besides the magnetically cooperating coupling parts, no other means are required to hold the front sheet against the frame.

[0021] Because most existing doors consist of the abovementioned traditional profiles with a lip, the invention is also suitable for the renovation of existing doors.

[0022] Useful in this is that the front sheet fully covers the front of the frame, so it appears as if the whole door is new. This can also be useful for new doors in giving

them a modern, clean-lined appearance.

[0023] Preferably, the first and second coupling parts are applied behind the front sheet so they are not visible in a finished door.

[0024] Preferably of each pair of first and second coupling parts at least one coupling part is in the form of a permanent magnet, while the other coupling part is made of a material that is attracted or repelled by a magnet, for example in the form of a second magnet or a steel plate.

[0025] If no intermediate sheet is provided, the dimensions of the rear sheet are a little smaller than the rabbet dimensions in the frame, and in that case the gap between the rear sheet and the rear of the frame is covered by panel slats or decorative slats.

[0026] If there is an intermediate sheet, the dimensions of the rear sheet are preferably greater than the rabbet dimensions of the frame and the dimensions of the intermediate sheet are a little smaller than these rabbet dimensions, whereby the intermediate sheet is pulled against the lip by the magnetic cooperation between the first and second coupling parts and the rear sheet is pulled against the rear of the frame by the magnetic cooperation between third and fourth coupling parts that are fastened to the intermediate sheet and the rear sheet respectively.

[0027] The advantages of the magnetic clamping means described for holding the front sheet on the frame are obviously also applicable to the magnetic fastening of the rear sheet on the frame.

[0028] In that case too, the third and fourth coupling parts are applied in an invisible way between the rear sheet and the intermediate sheet.

[0029] Preferably, the rear sheet covers the complete rear wall of the frame and the rear sheet is provided with folded over edges that engage over the outer circumference of the rear wall of the frame, for example fully around or only along the vertical edges.

[0030] The invention also relates to a panel kit for the assembly of a door leaf as described, starting with a frame made of traditional profiles with a lip to form a rabbet, whereby this panel kit contains at least one of the following elements or a combination of one or more of these elements:

- a front sheet with one or more first coupling parts attached on it at a distance of the circumference that are part of clamping means to be able to clamp the front sheet on the frame;
- second coupling parts for fastening on a rear sheet or on an intermediate sheet, whereby the second coupling parts can magnetically cooperate with the first coupling parts;
- a loose rear sheet and/or intermediate sheet that may or may not be provided with the second coupling parts.

[0031] With the intention of better showing the characteristics of the invention, some preferred embodiments

of a door leaf according to the invention are described hereinafter by way of examples, without any limiting nature, and of a panel kit for such a door leaf, with reference to the accompanying drawings, wherein:

figure 1 schematically shows an exterior door with PVC profiles according to the invention seen from the front;

figure 2 shows a cross-section according to line II-II in figure 1;

figure 3 shows the cross-section as shown in figure 3, however with the door leaf in the not assembled state on assembly;

figure 4 shows a rear view according to arrow F4 in figure 3;

figure 5 shows a variant of a door leaf according to the invention for an exterior door with PVC profiles; figures 6 to 8 show yet other variants of a door leaf according to the invention, however in this case for an exterior door with aluminium profiles.

[0032] The exterior door 1 shown in figure 1 includes a fixed door frame 2 intended to be attached in a wall hole and a door leaf 3 applied hingeably therein.

[0033] The door leaf 3 is made up of a frame 4 and a door panel 5 applied thereon that is in the form of a sandwich panel with a front sheet 6 on the front of the door, more in particular on the outside of the door 1, and a rear sheet 7 on the rear, more in particular on the inside of the door 1.

[0034] The front sheet 6 is for example made of an aluminium plate and the rear sheet 7 is for example made of an XPS plate covered on the visible side with an aluminium or PVC coating 8.

[0035] The frame 4 of the door leaf 3 is a traditional frame 4 that is made up of traditional profiles 9, for example of a synthetic material reinforced with an internal metal profile as shown in figures 2 to 5.

[0036] The profiles 9 have a front wall 10 and rear wall 11, on the front and the rear of the frame 4 respectively, an inside wall 12 and an outside wall 13, on the inner edge and on the outer edge of the frame 4 respectively, and on the inside wall 12 of the profiles 9 a lip 14 facing inwards to form a rabbet 15, whereby the lip 14 in the example shown is provided with a seal 16 along its entire profile length.

[0037] The front sheet 6 in the example shown covers the complete front wall of the frame 4 while the rear sheet 7 has dimensions larger than the dimensions A of the frame 4 along the inner circumference of the lip 14, but smaller than the rabbet dimensions B along the inside wall 12.

[0038] The rear sheet 7 is pulled to these seals 16 by means of coupling means 17 that are formed by first coupling parts 18a fastened on the rear of the front sheet 6 and by cooperating second coupling parts 18b fastened on the side of the rear sheet facing the front sheet 6.

[0039] The first and second coupling parts 18a and 18b

are provided to magnetically attract each other in the direction X-X' perpendicular to the surface of the front sheet 6.

[0040] In the example shown the second coupling parts 18b are provided as permanent magnets fastened by spacers 19 in plywood against the rear sheet, for example by means of screws 20.

[0041] The first coupling parts 18a are in this case in the form of steel plates that can be attracted by the magnets of the second coupling parts. Alternatively these first coupling parts 18a can also be in the form of permanent magnets.

[0042] The first coupling parts 18a are for example adhered to the rear of the front sheet 6, but can for example also be welded on it.

[0043] As shown in figure 4 the first coupling parts 18a are limited at a distance of the inner circumference of the frame 4 by the inner edges of the tabs 14 of the profiles 9.

[0044] The second coupling parts are applied in corresponding positions on the rear sheet 7.

[0045] Instead of using separate coupling parts 18 as in figure 4, coupling parts in the form of continuous magnetic tapes or strips can also be used.

[0046] The coupling parts 18a and 18b are assembled such that in the assembled state movement between the coupling parts 18a and 18b is possible in a direction Y-Y' parallel to the surface of the front sheet 6 so orthogonally with respect to the abovementioned direction X-X'.

[0047] To this end, the coupling parts are assembled such that their contact surface 21 faces parallel to the surface of the front sheet 6. A characteristic of magnetic coupling parts 18a and 18b is that they strongly attract each other in the direction X-X' corresponding with the N-S direction of the magnets and only offer low to no resistance against a movement in the direction Y-Y'.

[0048] The magnetic attractive force between the coupling parts 18a and 18b firmly clamps the lip 14 of the frame between the front sheet 6 and the rear sheet 7 as shown in figure 2.

[0049] A movement of the front sheet 6 with respect to the rear sheet 7 and the frame does however still remain possible in this assembled state.

[0050] That allows the possible lateral expansion of the front sheet 6 with respect to the frame without the warping of the front sheet 6 and without large internal stresses originating.

[0051] Once the front sheet and the rear sheet are assembled, the rabbet 15 between the circumference of the rear sheet 7 and the inside wall 12 of the frame 4 is covered by means of a panel slat 22 that is fastened around the rear side on the frame 4 and that is provided with a second seal 13 that presses on the rear of the door panel as clearly shown in figure 2, whereby the door panel 5 is held along its edges between the seals 16 and 23, of the lip 14 and of the panel slat 22 respectively.

[0052] Figure 5 shows a variant embodiment of a door leaf 3 according to the invention, whereby in this case a rear sheet 7 is applied together with an intermediate

sheet 24.

[0053] In this case the dimensions of the intermediate sheet 24 are larger than the dimensions A of the frame 4 along the inner circumference of the lip 14, but smaller than the rabbet dimensions B along the inside wall 12 and the intermediate sheet is pulled by the magnetic coupling parts 18a and 18b against the seal 16 of the lip 14.

[0054] In this case the rear sheet 7 covers the complete rear wall 11 of the frame and fits with a folded over edge over the circumference on the outside wall 13 of the frame 4.

[0055] This rear sheet 7 is pulled against the rear wall 11 of the frame 4 by the magnetic cooperation between third coupling parts 26a and fourth coupling parts 26b that are fastened to the intermediate sheet 24 and the rear sheet 7, respectively.

[0056] It is clear that instead of a magnetic coupling, the rear sheet can also be fastened in another mechanical way or by adhesion, this in combination with a magnetic coupling of the front sheet.

[0057] The intermediate sheet 24 can optionally be fastened in the frame 4 by means of an abovementioned panel slat 22 or by means of an additional profile 27 that lies against the rear of the intermediate sheet 24 and is fastened on the inside wall 12 of the frame 4, for example with a screw 28.

[0058] In figures 6 and 7 variant embodiments are shown of a door leaf 3 according to the invention that are analogous to the embodiments in figures 2 and 5 but with the difference that in this case the frame 4 is made up of traditional profiles 9 of aluminium instead of PVC.

[0059] The same characteristics are present as in figures 2 and 5.

[0060] Figure 8 shows a variant of figure 2 in which the first and second coupling parts 18a and 18b are both in the form of magnets assembled such that they repel each other in the direction X-X' and are assembled on the front sheet 6 and the rear sheet 7 with the repelling forces directed such that they push the front sheet 6 and the rear sheet 7 towards each other.

[0061] In this case the magnets 26a and 26b do not necessarily have to touch each other as appears from figure 8.

[0062] More generally, the coupling parts 18a and 18b and coupling parts 26a and 26b do not necessarily have to touch each other, also not if they attract each other. This means that the contact surface 21 in that case does not necessarily have to be parallel to the surface of the front sheet 6 to allow the lateral movement of the coupling parts with respect to each other.

[0063] The present invention is by no means limited to the embodiment as described as an example and shown in the drawings, but a door leaf and panel kit according to the invention can be realized in all kinds of variants and dimensions, without departing from the scope of the invention.

Claims

1. Door leaf comprising a frame (4) and a door panel (5) with a front sheet (6) and a rear sheet (7) and possibly an intermediate sheet between both, whereby the frame (4) is made up of traditional profiles (9) with a front wall (10) and rear wall (11), on the front and on the rear of the frame (4) respectively, an inside wall (12) and an outside wall (13), on the inside edge and outside edge of the frame (4) respectively, and on the inside wall (12) of the profiles (9) an inward facing lip (14) to form a rabbet (15) and whereby the front sheet (6) is applied against the front of the frame (4), covering the front of the frame (4) at least partly, **characterised in that** the front sheet (6) is fastened on the frame (4) by means of one or more first coupling parts (18a) fastened on the front sheet (6) and fastened by one or more cooperating second coupling parts (18b) fastened on the rear sheet (7) or on the intermediate sheet (24), whereby the first coupling parts (18a) and the second coupling parts (18b) are provided to magnetically attract or repel each other, in such a way that the rear sheet (7) or the intermediate sheet (24) hooks behind the abovementioned lip (14) by the magnetic cooperation of the coupling parts and is tightened to it such that a movement between the coupling parts (18a, 18b) is allowed in a direction (Y-Y') parallel to the surface of the front sheet (6).
2. Door leaf according to claim 1, **characterised in that** the front sheet (6) fully covers the front wall (10) of the frame (4).
3. Door leaf according to claim 1 or 2, **characterised in that**, besides the magnetically cooperating coupling parts (18a, 18b), no other means are required to hold the front sheet (6) against the frame (4).
4. Door leaf according to one of the previous claims, **characterised in that** the first coupling parts (18a) or at least a part of them are applied on the rear of the front sheet (6).
5. Door leaf according to one of the previous claims, **characterised in that** the second coupling parts (18b) or at least a part of them are applied on the side of the rear sheet (7) facing the front sheet (6) or of the intermediate sheet (24), if present, and this at a distance along the inner edge of the abovementioned inward facing lip (14) of the frame (4).
6. Door leaf according to one of the previous claims, **characterised in that** of each pair of first and second coupling parts (18a, 18b) at least one coupling part is a permanent magnet, while the other coupling part is made of a material that is attracted or repelled by a magnet.
7. Door leaf according to one of the previous claims, **characterised in that** the first coupling parts (18a) or at least a part of them are adhered to the front sheet (6).
8. Door leaf according to one of the previous claims, **characterised in that** the second coupling parts (18b) or at least a part of them are adhered or screwed on the rear sheet (7) or on the intermediate sheet (24), if present.
9. Door leaf according to one of the previous claims, **characterised in that** the dimensions of the rear sheet (7) are a little smaller than the rabbet dimensions (B) of the frame (4) and that the rabbet (15) between the door panel (5) on the rear of the frame (4) is covered by means of panel or decorative slats (22).
10. Door leaf according to claim 9, **characterised in that** the panel slats (22) are fastened on the frame (4) in a groove provided to this end on the inside wall (12) of the frame (4), with the panel slats (22) being provided with a seal (23) for sealing the rear sheet (7), whereby the thickness of the composed door leaf (3) is selected in such a way that the seals (23) of the panel slats (22) in the assembled state press on the rear of the rear sheet (7).
11. Door leaf according to one of claims 1 to 8, **characterised in that** the dimensions of the rear sheet (7) are larger than the rabbet dimensions (B) of the frame (4) and the dimensions of the intermediate sheet (24) are a little smaller than these rabbet dimensions (B) of the frame (4), whereby the intermediate sheet (24) is attracted to the lip (14) by the magnetic cooperation between the first and second coupling parts (18a, 18b) and the rear sheet (7) is attracted against the rear wall (11) of the frame (4) by the magnetic cooperation between third and fourth coupling parts (26a, 26b) that are fastened to the intermediate sheet (24) and the rear sheet (7) respectively.
12. Door leaf according to claim 11, **characterised in that** the fourth coupling parts (26b) or at least a part of them are applied concealed on the side of the rear sheet (7) facing the intermediate sheet (24).
13. Door leaf according to claim 11 or 12, **characterised in that** the fourth coupling parts (26b) or at least a part of them are adhered to the rear sheet (7).
14. Door leaf according to one of claims 11 to 13, **characterised in that** the intermediate sheet (24) is held in the frame (4) by an additional profile (27) that lies against the rear of the intermediate sheet (24) and is fastened on the inside wall (12) of the frame (4).

15. Door leaf according to one of claims 11 to 14, **characterised in that** the rear sheet (7) covers the complete rear wall (11) of the frame (4) and is provided with folded over edges (25) that engage over the outer circumference of the rear wall (11) of the frame (4). 5
16. Door leaf according to one of the previous claims, **characterised in that** the front sheet (6) is an aluminium plate. 10
17. Door leaf according to one of the previous claims, **characterised in that** the rear sheet (7) is a plate of aluminium or a plate of which the rear is provided with an aluminium or PVC coating. 15
18. Panel kit for the assembly of a door leaf according to one of claims 1 to 17 starting with a frame (4) made of traditional profiles (9) with a lip (14) to form a rabbet (15), **characterised in that** this panel kit comprises the following elements : 20
- a front sheet (6) with one or more first coupling parts (18a) attached to it at a distance from the circumference to clamp the front sheet (6) on the frame (4) ; 25
 - a loose rear sheet (7) and/or intermediate sheet (24) provided with second coupling parts (18b), said second coupling parts (18b) fastened on the rear sheet (7) or on the intermediate sheet (24), with the second coupling parts (18b) able to magnetically cooperate with the first coupling parts (18a). 30
- Patentansprüche**
1. Türblatt, umfassend einen Rahmen (4) und ein Türpaneel (5) mit einer Vorderplatte (6) und einer Hinterplatte (7) und eventuell einer Zwischenplatte zwischen beiden, wobei der Rahmen (4) aus herkömmlichen Profilen (9) mit einer Vorderwand (10) und Hinterwand (11) an der Vorderseite beziehungsweise an der Hinterseite des Rahmens (4) zusammengestellt ist, einer Innenwand (12) und einer Außenwand (13) am Innenrand beziehungsweise dem Außenrand des Rahmens (4), und an der Innenwand (12) der Profile (9) einer einwärts gerichteten Lippe (14) zur Bildung eines Falzes (15), und wobei die Vorderplatte (6) gegen die Vorderseite des Rahmens (4) angebracht ist, wobei sie die Vorderseite des Rahmens (4) mindestens teilweise überdeckt, **dadurch gekennzeichnet, dass** die Vorderplatte (6) mittels eines oder mehrerer erster Koppelteile (18a), die an der Vorderplatte (6) befestigt sind, und mittels eines oder mehrerer damit zusammenwirkender zweiter Koppelteile (18b), die an der Hinterplatte (7) oder an der Zwischenplatte (24) befestigt sind, an dem Rahmen (4) befestigt wird, wobei die ersten Koppelteile (18a) und die zweiten Koppelteile (18b) vorgesehen sind, um einander magnetisch anzuziehen oder abzustößen, derart, dass die Hinterplatte (7) oder die Zwischenplatte (24) durch das magnetische Zusammenwirken der Koppelteile hinter der vorgenannten Lippe (14) einhakt und dagegen angezogen wird, derart, dass eine Bewegung zwischen den Koppelteilen (18a, 18b) in einer Richtung (Y-Y') parallel zur Fläche der Vorderplatte (6) zugelassen wird. 35
2. Türblatt nach Anspruch 1, **dadurch gekennzeichnet, dass** die Vorderplatte (6) die Vorderwand (10) des Rahmens (4) vollständig überdeckt. 40
3. Türblatt nach Anspruch 1 oder 2, **dadurch gekennzeichnet, dass**, außer den magnetisch zusammenwirkenden Koppelteilen (18a, 18b), keine anderen Mittel erforderlich sind, um die Vorderplatte (6) gegen den Rahmen (4) festzuhalten. 45
4. Türblatt nach einem der vorhergehenden Ansprüche, **dadurch gekennzeichnet, dass** die ersten Koppelteile (18a) oder mindestens ein Teil davon an der Rückseite der Vorderplatte (6) angebracht sind. 50
5. Türblatt nach einem der vorhergehenden Ansprüche, **dadurch gekennzeichnet, dass** die zweiten Koppelteile (18b) oder mindestens ein Teil davon an der zu der Vorderplatte (6) gerichteten Seite der Hinterplatte (7) oder der Zwischenplatte (24), falls vorhanden, angebracht sind, und zwar in einem Abstand entlang dem Innenrand der vorgenannten einwärts gerichteten Lippe (14) des Rahmens (4). 55
6. Türblatt nach einem der vorhergehenden Ansprüche, **dadurch gekennzeichnet, dass** von jedem Paar erster und zweiter Koppelteile (18a, 18b) mindestens ein Koppelteil ein Permanentmagnet ist, während das andere Koppelteil aus einem Material hergestellt ist, das von einem Magneten angezogen oder abgestoßen wird. 60
7. Türblatt nach einem der vorhergehenden Ansprüche, **dadurch gekennzeichnet, dass** die ersten Koppelteile (18a) oder mindestens ein Teil davon an die Vorderplatte (6) geklebt sind. 65
8. Türblatt nach einem der vorhergehenden Ansprüche, **dadurch gekennzeichnet, dass** die zweiten Koppelteile (18b) oder mindestens ein Teil davon an die Hinterplatte (7) oder an die Zwischenplatte (24), falls vorhanden, geklebt oder geschraubt sind. 70
9. Türblatt nach einem der vorhergehenden Ansprüche, **dadurch gekennzeichnet, dass** die Abmessungen der Hinterplatte (7) etwas kleiner als die

Falzabmessungen (B) des Rahmens (4) sind und dass der Falz (15) zwischen dem Türpaneel (5) an der Rückseite des Rahmens (4) mittels Paneel- oder Dekorleisten (22) abgedeckt ist.

10. Türblatt nach Anspruch 9, **dadurch gekennzeichnet, dass** die Paneelleisten (22) in einer zu diesem Zweck an der Innenwand (12) des Rahmens (4) vorgesehenen Nut an dem Rahmen (4) befestigt sind, welche Paneelleisten (22) mit einer Dichtung (23) zur Abdichtung der Hinterplatte (7) versehen sind, wobei die Dicke des zusammengestellten Türblatts (3) so ausgewählt ist, dass die Dichtungen (23) der Paneelleisten (22) im montierten Zustand auf die Rückseite der Hinterplatte (7) drücken.

11. Türblatt nach einem der Ansprüche 1 bis 8, **dadurch gekennzeichnet, dass** die Abmessungen der Hinterplatte (7) größer als die Falzabmessungen (B) des Rahmens (4) sind und die Abmessungen der Zwischenplatte (24) etwas kleiner als diese Falzabmessungen (B) des Rahmens (4) sind, wobei die Zwischenplatte (24) durch das magnetische Zusammenwirken zwischen den ersten und zweiten Koppelteilen (18a, 18b) gegen die Lippe (14) angezogen wird und die Hinterplatte (7) durch das magnetische Zusammenwirken zwischen dritten und vierten Koppelteilen (26a, 26b), die an der Zwischenplatte (24) beziehungsweise der Hinterplatte (7) befestigt sind, gegen die Rückwand (11) des Rahmens (4) angezogen wird.

12. Türblatt nach Anspruch 11, **dadurch gekennzeichnet, dass** die vierten Koppelteile (26b) oder mindestens ein Teil davon verborgen an der zu der Zwischenplatte (24) gerichteten Seite der Hinterplatte (7) angebracht sind.

13. Türblatt nach Anspruch 11 oder 12, **dadurch gekennzeichnet, dass** die vierten Koppelteile (26b) oder mindestens ein Teil davon an die Hinterplatte (7) geklebt sind.

14. Türblatt nach einem der Ansprüche 11 bis 13, **dadurch gekennzeichnet, dass** die Zwischenplatte (24) durch ein zusätzliches Profil (27) in dem Rahmen (4) festgehalten wird, das gegen die Rückseite der Zwischenplatte (24) anliegt und an der Innenwand (12) des Rahmens (4) befestigt ist.

15. Türblatt nach einem der Ansprüche 11 bis 14, **dadurch gekennzeichnet, dass** die Hinterplatte (7) die vollständige Rückwand (11) des Rahmens (4) bedeckt und mit umgebogenen Rändern (25) versehen ist, die über den Außenumfang der Rückwand (11) des Rahmens (4) greifen.

16. Türblatt nach einem der vorhergehenden Ansprü-

che, **dadurch gekennzeichnet, dass** die Vorderplatte (6) eine Aluminiumplatte ist.

17. Türblatt nach einem der vorhergehenden Ansprüche, **dadurch gekennzeichnet, dass** die Hinterplatte (7) eine Platte aus Aluminium ist oder eine Platte, deren Rückseite mit einer Aluminium- oder PVC-Verkleidung versehen ist.

18. Paneelset zum Zusammenstellen eines Türblatts nach einem der Ansprüche 1 bis 17, ausgehend von einem Rahmen (4), der aus herkömmlichen Profilen (9) mit einer Lippe (14) zur Bildung eines Falzes (15) hergestellt ist, **dadurch gekennzeichnet, dass** dieses Paneelset die folgenden Elemente umfasst:

- eine Vorderplatte (6) mit einem oder mehreren in einem Abstand von dem Umfangsrand daran befestigten ersten Koppelteilen (18a) zum Festklemmen der Vorderplatte (6) an dem Rahmen (4);

- eine lose Hinterplatte (7) und/oder Zwischenplatte (24), die mit zweiten Koppelteilen (18b) versehen ist, welche zweiten Koppelteile (18b) an der Hinterplatte (7) oder an der Zwischenplatte (24) befestigt sind, wobei die zweiten Koppelteile (18b) magnetisch mit den ersten Koppelteilen (18a) zusammenwirken können.

Revendications

1. Battant de porte comprenant un encadrement (4) et un panneau de porte (5) muni d'une feuille avant (6) et d'une feuille arrière (7) et, le cas échéant, d'une feuille intermédiaire entre les deux ; dans lequel l'encadrement (4) est constitué par des profilés traditionnels (9) comprenant une paroi avant (10) et une paroi arrière (11), sur l'avant et sur l'arrière de l'encadrement (4) respectivement, une paroi interne (12) et une paroi externe (13), sur le bord interne et le bord externe de l'encadrement (4) respectivement, et sur la paroi interne (12) des profilés (9) une lèvre (14) orientée vers l'intérieur pour former une feuillure (15) ; et dans lequel la feuille avant (6) est appliquée contre l'avant de l'encadrement (4) en recouvrant l'avant de l'encadrement (4) au moins en partie ; **caractérisé en ce que** la feuille avant (6) est fixée sur l'encadrement (4) au moyen d'un ou de plusieurs premiers éléments d'accouplement (18a) fixés sur la feuille avant (6) et fixés par un ou plusieurs seconds éléments d'accouplement coopérant (18b) fixés sur la feuille arrière (7) ou sur la feuille intermédiaire (24) ; dans lequel les premiers éléments d'accouplement (18a) et les seconds éléments d'accouplement (18b) sont prévus pour s'attirer ou se repousser l'un l'autre par voie magnétique, d'une manière telle que la feuille arrière (7) ou la

- feuille intermédiaire (24) s'accroche derrière la lèvre susmentionnée (14) par la coopération magnétique des éléments d'accouplement et y est serrée d'une manière telle qu'un mouvement entre les éléments d'accouplement (18a, 18b) est permis dans une direction (Y-Y') parallèle à la surface de la feuille avant (6).
2. Battant de porte selon la revendication 1, **caractérisé en ce que** la feuille avant (6) recouvre complètement la paroi avant (10) de l'encadrement (4).
 3. Battant de porte selon la revendication 1 ou 2, **caractérisé en ce que**, en dehors des éléments d'accouplement (18a, 18b) coopérant par voie magnétique, aucun autre moyen n'est requis pour maintenir la feuille avant (6) contre l'encadrement (4).
 4. Battant de porte selon l'une quelconque des revendications précédentes, **caractérisé en ce que** les premiers éléments d'accouplement (18a) ou au moins une partie d'entre eux sont appliqués sur l'arrière de la feuille avant (6).
 5. Battant de porte selon l'une quelconque des revendications précédentes, **caractérisé en ce que** les seconds éléments d'accouplement (18a) ou au moins une partie d'entre eux sont appliqués sur le côté de la feuille arrière (7) orienté vers la feuille avant (6) ou vers la feuille intermédiaire (24), lorsque celle-ci est présente, et ceci à une distance le long du bord interne de la lèvre susmentionnée (14) de l'encadrement (4), orientée vers l'intérieur.
 6. Battant de porte selon l'une quelconque des revendications précédentes, **caractérisé en ce que**, parmi chaque paire de premiers et seconds éléments d'accouplement (18a, 18b), au moins un élément d'accouplement représente un aimant permanent, tandis que l'autre élément d'accouplement est réalisé en un matériau qui est attiré ou repoussé par un aimant.
 7. Battant de porte selon l'une quelconque des revendications précédentes, **caractérisé en ce que** les premiers éléments d'accouplement (18a) ou au moins une partie d'entre eux adhèrent à la feuille avant (6).
 8. Battant de porte selon l'une quelconque des revendications précédentes, **caractérisé en ce que** les seconds éléments d'accouplement (18b) ou au moins une partie d'entre eux adhèrent à ou sont vissés sur la feuille arrière (7) ou à ou sur la feuille intermédiaire (24) lorsque celle-ci est présente.
 9. Battant de porte selon l'une quelconque des revendications précédentes, **caractérisé en ce que** les dimensions de la feuille arrière (7) sont légèrement inférieures aux dimensions (B) de la feuillure de l'encadrement (4) et **en ce que** la feuillure (15) entre le panneau de porte (5) sur l'arrière de l'encadrement (4) est recouvert au moyen de lattes de panneaux ou de lattes décoratives (22).
 10. Battant de porte selon la revendication 9, **caractérisé en ce que** les lattes de panneaux (22) sont fixées sur l'encadrement (4) dans une rainure prévue à cet effet sur la paroi interne (12) de l'encadrement (4), les lattes de panneaux (22) étant munies d'un joint d'étanchéité (23) pour l'étanchéisation de la feuille arrière (7) ; dans lequel l'épaisseur du battant de porte composite (3) est choisie d'une manière telle que les joints d'étanchéité (23) des lattes de panneaux (22) à l'état assemblé exercent une pression sur l'arrière de la feuille arrière (7).
 11. Battant de porte selon l'une quelconque des revendications 1 à 8, **caractérisé en ce que** les dimensions de la feuille arrière (7) sont supérieures aux dimensions (B) de la feuillure de l'encadrement (4) et les dimensions de la feuille intermédiaire (24) sont légèrement inférieures à ces dimensions (B) de la feuillure de l'encadrement (4) ; dans lequel la feuille intermédiaire (24) est attirée en direction de la lèvre (14) par la coopération magnétique entre les premiers et seconds élément d'accouplement (18a, 18b) et la feuille arrière (7) est attirée contre la paroi arrière (11) de l'encadrement (4) par la coopération magnétique entre des troisièmes et quatrièmes éléments d'accouplement (26a, 26b) qui sont fixés à la feuille intermédiaire (24) et à la feuille arrière (7), respectivement.
 12. Battant de porte selon la revendication 11, **caractérisé en ce que** les quatrièmes éléments d'accouplement (26) ou au moins une partie d'entre eux sont appliqués en étant dissimulés sur le côté de la feuille arrière (7) orienté vers la feuille intermédiaire (24).
 13. Battant de porte selon la revendication 11 ou 12, **caractérisé en ce que** les quatrièmes éléments d'accouplement (26) ou au moins une partie d'entre eux adhèrent à la feuille arrière (7).
 14. Battant de porte selon l'une quelconque des revendications 11 à 13, **caractérisé en ce que** la feuille intermédiaire (24) est maintenue dans l'encadrement (4) par un profilé supplémentaire (27) qui vient se disposer contre l'arrière de la feuille intermédiaire (24) et qui est fixé sur la paroi interne (12) de l'encadrement (4).
 15. Battant de porte selon l'une quelconque des revendications 11 à 14, **caractérisé en ce que** la feuille arrière (7) recouvre la totalité de la paroi arrière (11)

de l'encadrement (4) et est munie de bords repliés (25) qui viennent se disposer par-dessus la circonférence externe de la paroi arrière (11) de l'encadrement (4).

5

16. Battant de porte selon l'une quelconque des revendications précédentes, **caractérisé en ce que** la feuille avant (6) est une plaque d'aluminium.

17. Battant de porte selon l'une quelconque des revendications précédentes, **caractérisé en ce que** la feuille arrière (7) est une plaque d'aluminium ou une plaque dont l'arrière est muni d'un revêtement d'aluminium ou de PVC.

10

15

18. Nécessaire de panneaux pour le montage d'un battant de porte selon l'une quelconque des revendications 1 à 17, en commençant avec un encadrement (4) constitué par des profilés traditionnels (9) munis d'une lèvre (14) pour former une feuillure (15), **caractérisé en ce que** ce nécessaire de panneaux comprend les éléments suivants :

20

- une feuille avant (6) comprenant un ou plusieurs premiers éléments d'accouplement (18a) qui y sont fixés à une distance par rapport à la circonférence afin de serrer la feuille avant (6) sur l'encadrement (4) ;

25

- une feuille arrière détachée (4) et/ou une feuille intermédiaire (24) munie(s) de seconds éléments d'accouplement (18b), lesdits seconds éléments d'accouplement (18b) étant fixés sur la feuille arrière (7) ou sur la feuille intermédiaire (24), les seconds éléments d'accouplement (18b) étant capables de coopérer par voie magnétique avec les premiers éléments d'accouplement (18a).

30

35

40

45

50

55

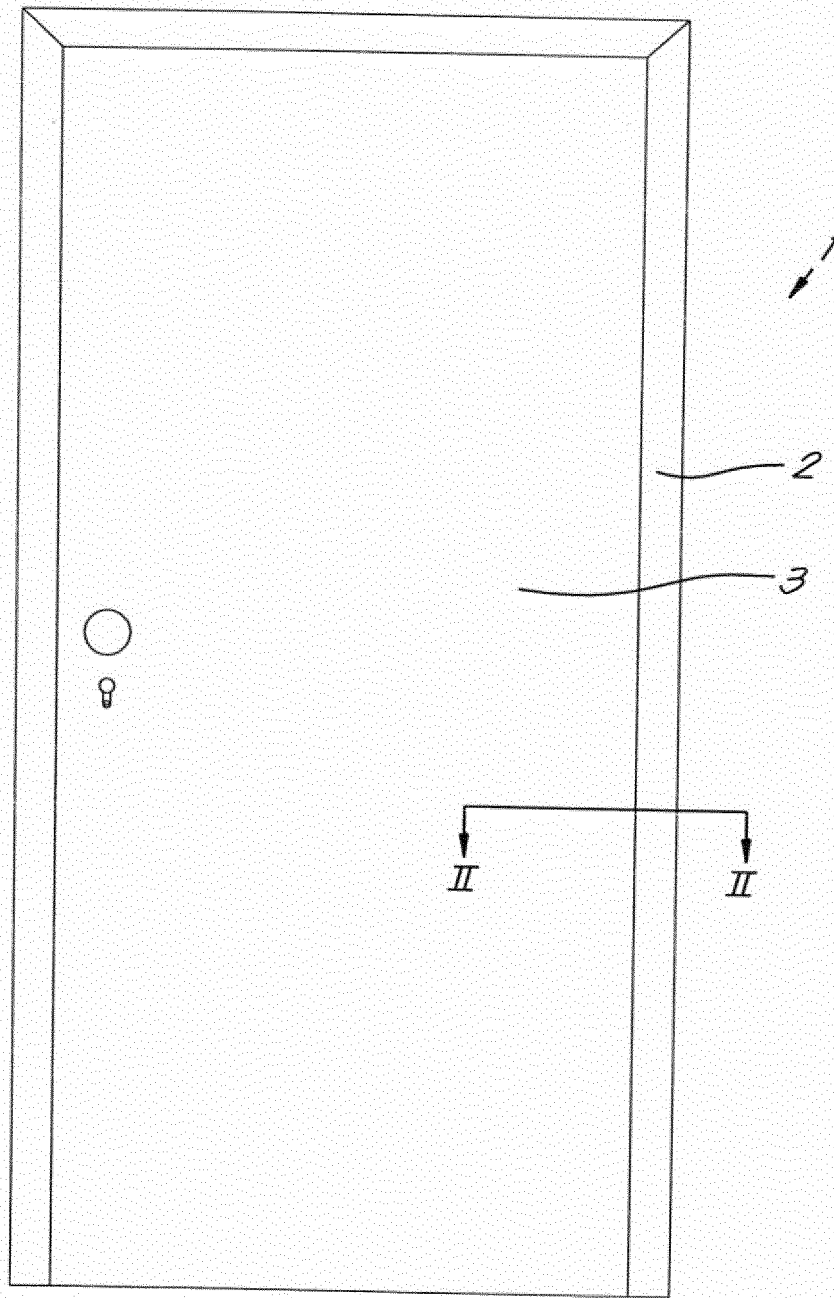

Fig. 1

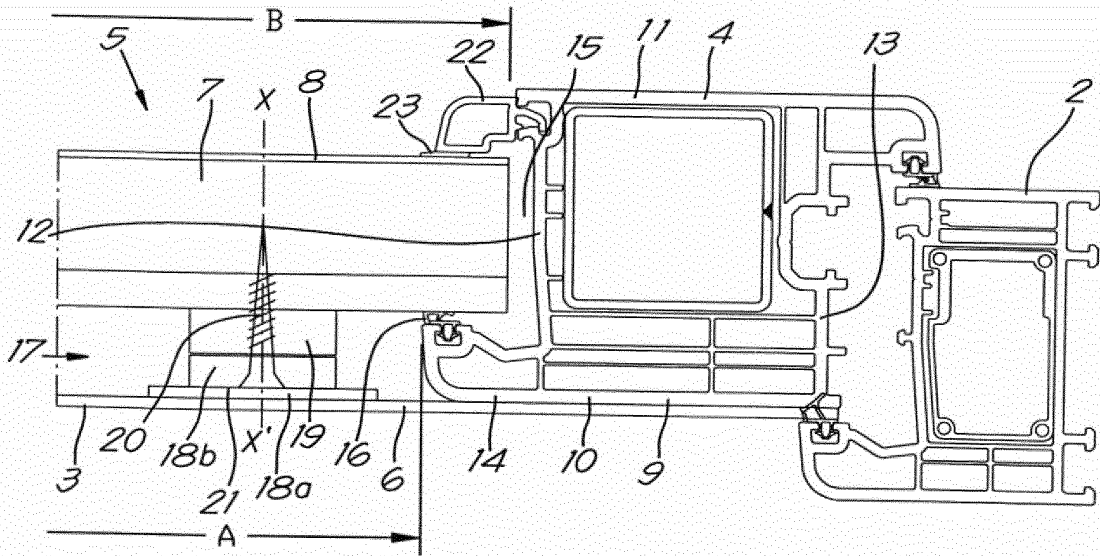

Fig. 2

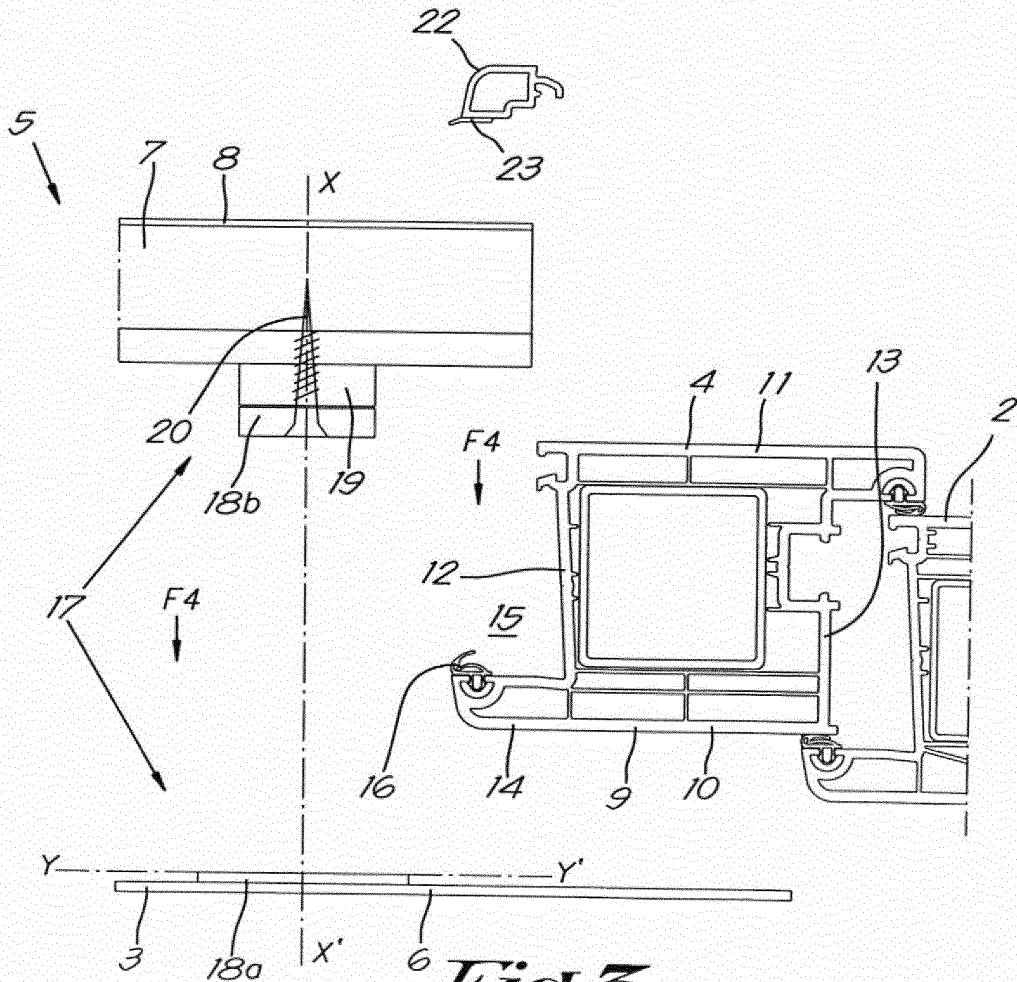

Fig. 3

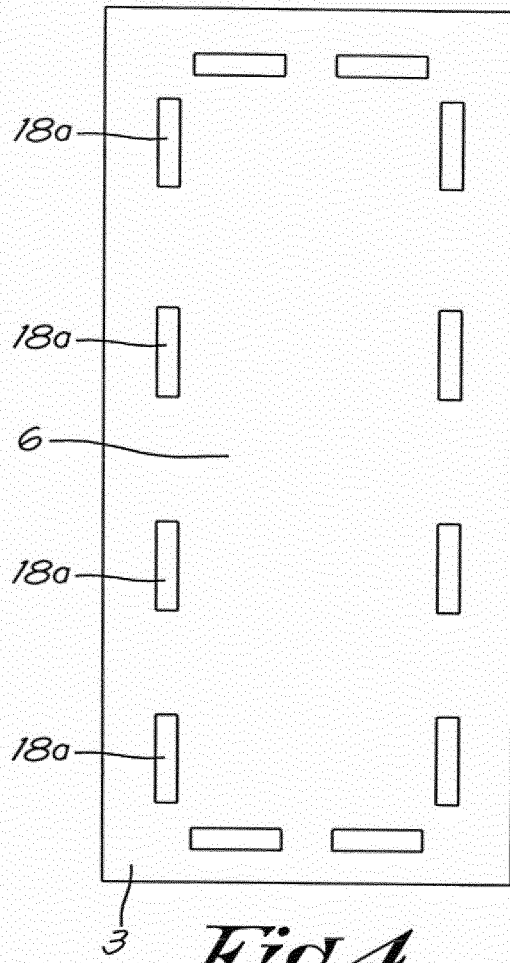

Fig. 4

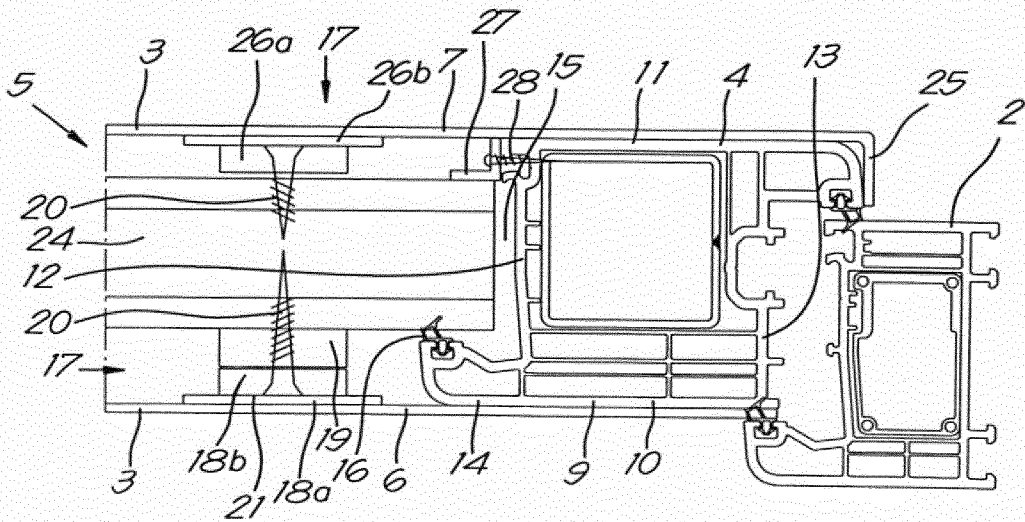

Fig. 5

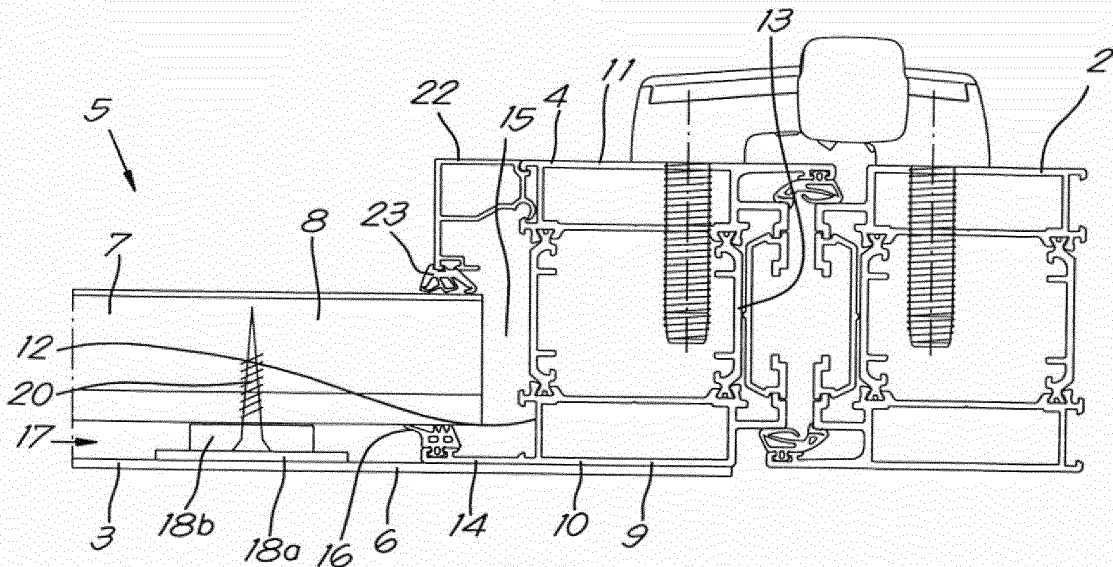

Fig. 6

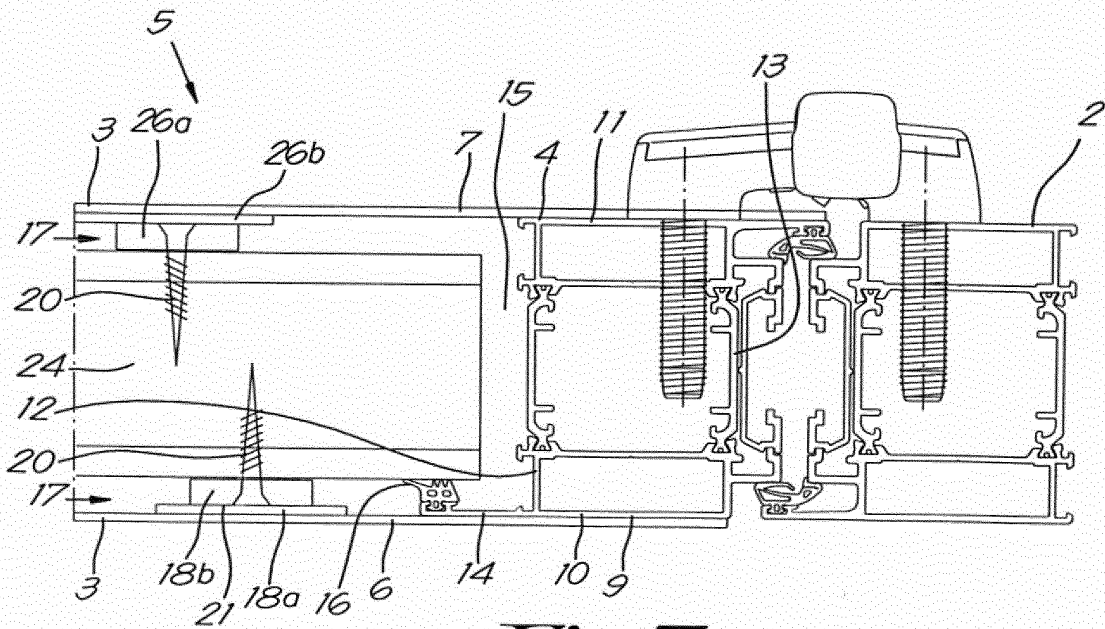

Fig. 7

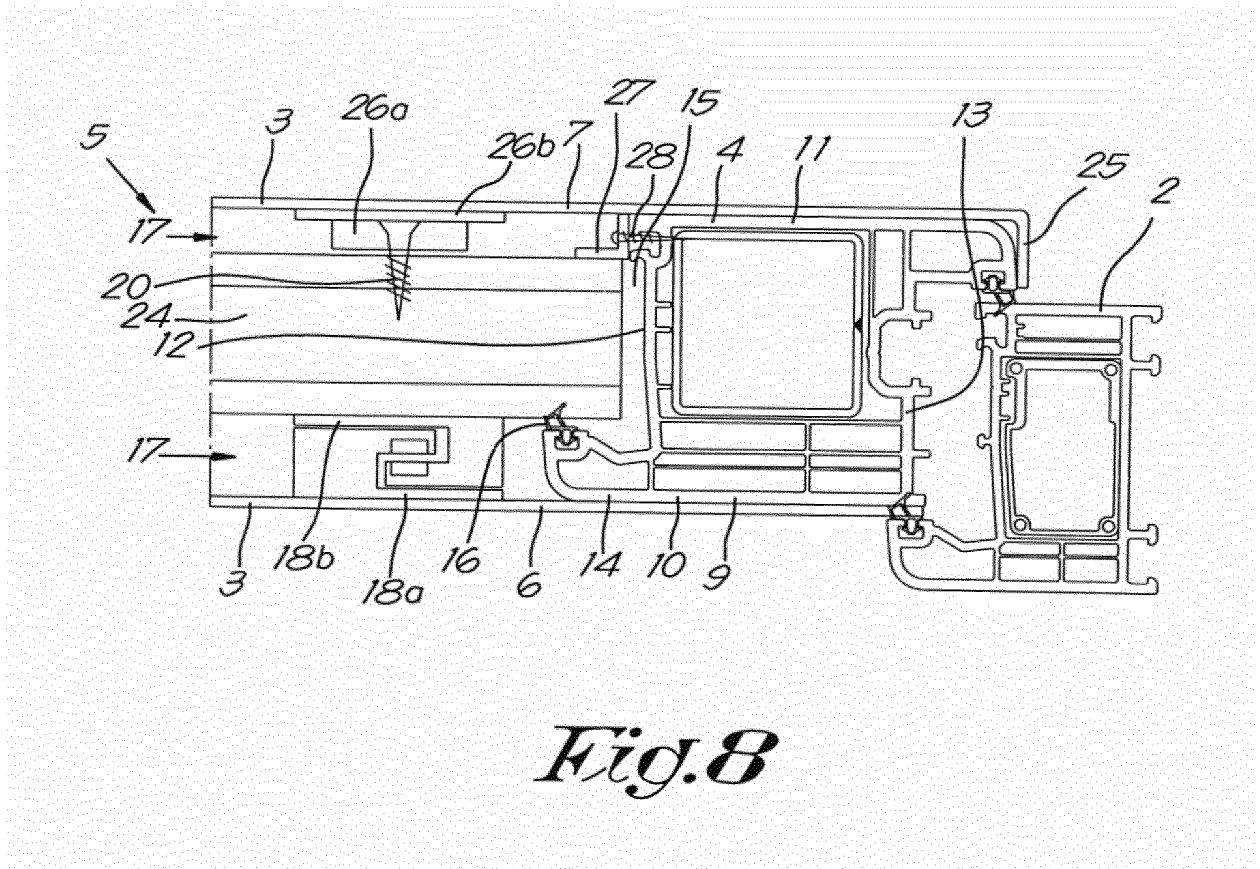

Fig. 8

REFERENCES CITED IN THE DESCRIPTION

This list of references cited by the applicant is for the reader's convenience only. It does not form part of the European patent document. Even though great care has been taken in compiling the references, errors or omissions cannot be excluded and the EPO disclaims all liability in this regard.

Patent documents cited in the description

- WO 2016112437 A [0010]