

W. M. Kay,

Faucet.

No. 104,050.

Patented June 17, 1870.

Fig. 1.

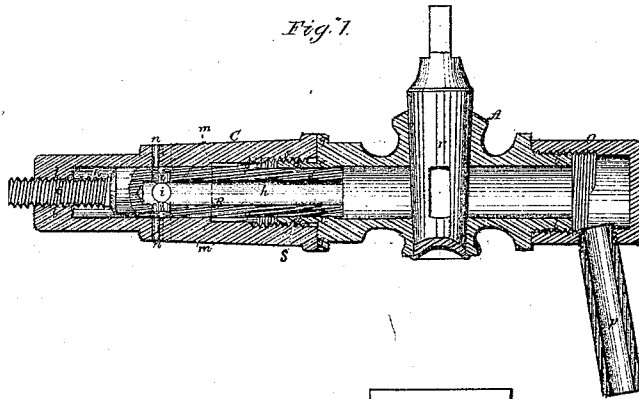

Fig. 2.

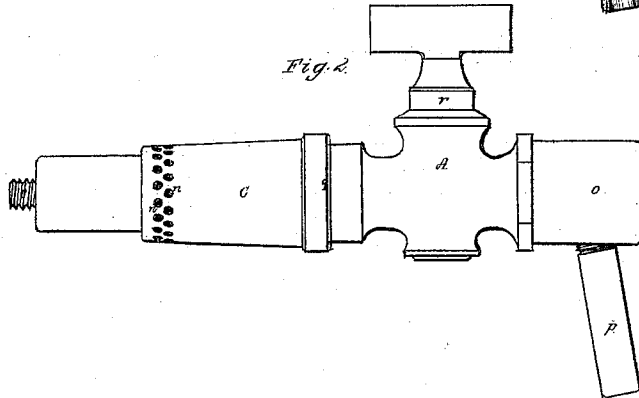

Fig. 3.

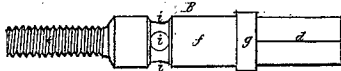
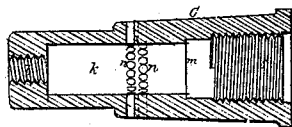
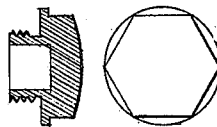

Fig. 4.



Auxiliary Figures.



Witnesses

S. N. Piper

J. R. Snow

Wm. M. Kay.

by his attorney

R. W. Huddy

United States Patent Office.

WILLIAM MCKAY, OF NEWBURYPORT, MASSACHUSETTS, ASSIGNOR TO HIMSELF AND CHARLES E. BAYLEY.

Letters Patent No. 104,050, dated June 7, 1870.

IMPROVEMENT IN FAUCETS.

The Schedule referred to in these Letters Patent and making part of the same.

To all persons to whom these presents may come:

Be it known that I, WILLIAM MCKAY, of Newburyport, of the county of Essex and State of Massachusetts, have made a new and useful invention or improvement having reference to Taps and Faucets for Beer or other Barrels; and do hereby declare the same to be fully described in the following specification and represented in the accompanying drawing, of which—

Figure 1 is a longitudinal section, and

Figure 2 is an external elevation of a tap and faucet embodying my invention.

Figure 3 is a side view of the tubular key of the tap.

In this case the tap becomes an auxiliary faucet, to be opened by the primary faucet during the act of screwing it into the tap, the said tap being, also, closed by and during the act of separating the primary faucet from it.

The said primary faucet, shown at A in the drawing, is like a common stop-cock, except that one of its connection-screws, *a*, *b*, (viz, that marked *a*), is formed with a prismatic bore, *c*, to receive and fit upon the prismatic head *d* of the rotary key B of the auxiliary faucet or "tap," as it may be termed.

The screw *a* is to have its thread pitched in a direction opposite to that of the male screw *e* of the key B. In other words, the screw *a* is to be a "right" and the screw *e* a "left" screw.

The body *f* of the key B is cylindrical, and is provided with a flange, *g*, extended from it and the prismatic head *d*. It also has a male screw, *e*, projected from it, the whole being formed and arranged as represented.

Furthermore, a passage, *h*, is bored or made axially into the key B from its outer end, and has one or more passages, *i*, leading laterally out of it, near its inner end.

The plug C, or body of the auxiliary faucet or tap, is constructed with a cylindrical chamber, *k*, (see Figure 4,) which is a longitudinal section of the plug as it appears when separated from its key.

From the rear end of the chamber a female screw, *l*, is cut through the plug to receive the screw *e* of the key.

Furthermore, at the front end of the said chamber, is a shoulder, *m*, for the flange *g* to bring up against.

The body C also has another female screw, *s*, made in it, to receive the screw *a* of the main faucet.

The diameter of the plug-chamber *k* corresponds to the diameter of the part or body *f* of the key, and there is led laterally out of the chamber *k* by one or more holes, *n*, which go through the plug C.

The plug is made slightly tapering, so that it may be driven into and caused to closely fit to a hole when made to receive it in the head of a barrel.

The screw *b* of the main faucet is provided with a thimble, *o*, which screws upon it, and has a pipe or

tube, P, leading laterally from it, and opening out of the internal space of such thimble, in manner as represented.

The thimble and the tube enable the faucet to be used for filling a bottle or jug with liquid.

When the plug C is in the head of a barrel, the passages *n* should project into the barrel a short distance beyond such head.

While the tubular key B may be screwed onto the plug far enough to carry the lateral passages *i* beyond the lateral passages *n*, no liquid can flow from the barrel through the passages *n* and into and through the passages *i*, and thence into the bore *h*. Consequently, the barrel will be closed by the auxiliary faucet or tap. But, on screwing the main or primary faucet into the tap, the key B will be revolved, its screw *e* in the meantime causing the key to move endwise until the holes *i* may be carried opposite the holes *n*, which will have taken place when the primary faucet may have been fully screwed into the plug, so as to carry the shoulder *q* of the screw *a* up to the end of the plug.

As soon as the lateral passages of the key and body of the plug may be brought into conjunction, liquid from the cask or barrel will flow into the bore *h*, and thence into the primary faucet, from which it may be discharged by properly turning the key *r* thereof, so as to allow the liquid to flow through it.

I am aware of the invention described in the United States patent No. 62,864, the purpose of which is to force, by means of a faucet, a plug out of its hole in a barrel. I make no claim to such invention, as, although in some respects it is analogous to my apparatus, as described, yet in others it differs materially; that is to say, the part which is fixed to the barrel is simply a female screw to receive a hollow screw projecting from the faucet, whereas, in my apparatus, I employ, in connection with the main faucet, an auxiliary faucet, as described, to be closed and opened by the main faucet.

I claim—

The combination of the tubular key B, provided with the cylindrical body *f*, one or more lateral passages, *i*, the screw *e*, and the prismatic head *d*, with the body C, as having the cylindrical chamber *k*, the opposite female screws *l* *s*, and one or more lateral passages, *n*, all the parts being constructed and arranged substantially as described.

Also, the combination of the above with the main faucet, as constructed, with the key-receiving socket *c* and the male screw *a*, arranged with such socket, and for the coupling with the screw *s* of the tap C, as set forth.

WILLIAM MCKAY.

Witnesses:

BENJ'N GOODWIN,
CHAS. W. PIKE.