

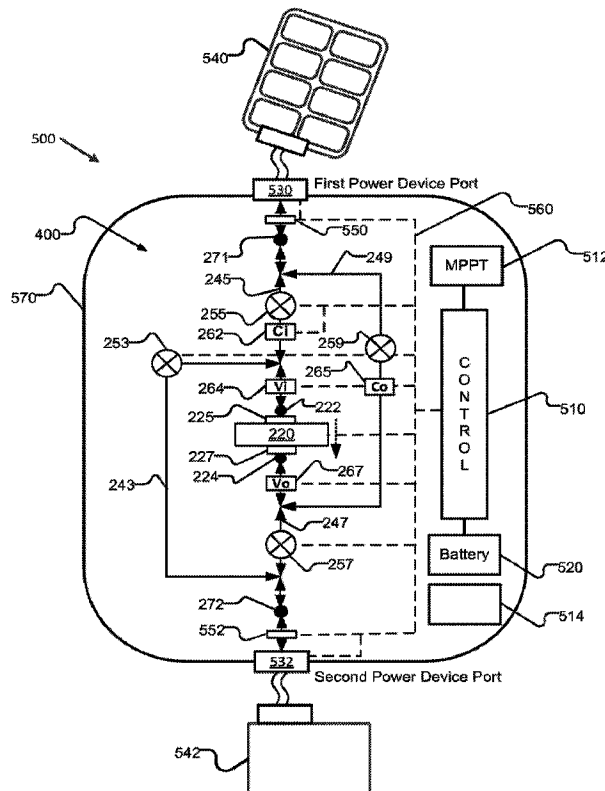

(86) Date de dépôt PCT/PCT Filing Date: 2020/05/15
 (87) Date publication PCT/PCT Publication Date: 2020/11/26
 (45) Date de délivrance/Issue Date: 2024/01/09
 (85) Entrée phase nationale/National Entry: 2021/10/29
 (86) N° demande PCT/PCT Application No.: US 2020/033207
 (87) N° publication PCT/PCT Publication No.: 2020/236623
 (30) Priorité/Priority: 2019/05/17 (US16/415,336)

(51) Cl.Int./Int.Cl. *H02J 1/00* (2006.01),
G06F 1/26 (2006.01), *G06F 13/40* (2006.01),
H02J 1/08 (2006.01)
 (72) Inventeurs/Inventors:
LONG, DAVID N., US;
PIELA, NICHOLAS J., US;
BUTLER, DAVID J., US
 (73) Propriétaire/Owner:
GALVION SOLDIER POWER, LLC, US
 (74) Agent: BERUBE PATENT SERVICES

(54) Titre : GESTIONNAIRE DE PUISSANCE A CIRCUITS DE CONVERSION DE PUISSANCE RECONFIGURABLES
 (54) Title: POWER MANAGER WITH RECONFIGURABLE POWER CONVERTING CIRCUITS



(57) Abrégé/Abstract:

A reconfigurable power circuit (400) includes a single one-way DC to DC power converter (220, 221). The reconfigurable power circuit is configurable by a digital data processor as one of three different power channels (230, 232, and 234). Power channel (230) provides output power conversion. Power channel (232) provides input power conversion. Power channel (234) provides bi-directional power exchange without power conversion.

(12) INTERNATIONAL APPLICATION PUBLISHED UNDER THE PATENT COOPERATION TREATY (PCT)

(19) World Intellectual Property
Organization
International Bureau



(10) International Publication Number
WO 2020/236623 A1

(43) International Publication Date
26 November 2020 (26.11.2020)

(51) International Patent Classification:

H02J 1/00 (2006.01) G06F 13/40 (2006.01)
G06F 1/26 (2006.01) H02J 1/08 (2006.01)

(21) International Application Number:

PCT/US2020/033207

(22) International Filing Date:

15 May 2020 (15.05.2020)

(25) Filing Language:

English

(26) Publication Language:

English

(30) Priority Data:

16/415,336 17 May 2019 (17.05.2019) US

(71) Applicant: **REVISION MILITARY LTD.** [US/US]; 7 Corporate Drive, Essex, Vermont 05452 (US).

(72) Inventors: **LONG, David, N.**; 1 Sawmill Drive, Northborough, Massachusetts 01532 (US). **PIELA, Nicholas, J.**; 28 Pleasant View Road, Wilbraham, Massachusetts 01095 (US). **BUTLER, David, J.**; 1562 9th Avenue, SE, Rochester, Minnesota 55904 (US).

(74) Agent: **CHACLAS, George, N.** et al.; Burns & Levinson, LLP, 125 High Street, Boston, Massachusetts 02110 (US).

(81) Designated States (unless otherwise indicated, for every kind of national protection available): AE, AG, AL, AM, AO, AT, AU, AZ, BA, BB, BG, BH, BN, BR, BW, BY, BZ,

CA, CH, CL, CN, CO, CR, CU, CZ, DE, DJ, DK, DM, DO, DZ, EC, EE, EG, ES, FI, GB, GD, GE, GH, GM, GT, HN, HR, HU, ID, IL, IN, IR, IS, JO, JP, KE, KG, KH, KN, KP, KR, KW, KZ, LA, LC, LK, LR, LS, LU, LY, MA, MD, ME, MG, MK, MN, MW, MX, MY, MZ, NA, NG, NI, NO, NZ, OM, PA, PE, PG, PH, PL, PT, QA, RO, RS, RU, RW, SA, SC, SD, SE, SG, SK, SL, ST, SV, SY, TH, TJ, TM, TN, TR, TT, TZ, UA, UG, US, UZ, VC, VN, WS, ZA, ZM, ZW.

(84) Designated States (unless otherwise indicated, for every kind of regional protection available): ARIPO (BW, GH, GM, KE, LR, LS, MW, MZ, NA, RW, SD, SL, ST, SZ, TZ, UG, ZM, ZW), Eurasian (AM, AZ, BY, KG, KZ, RU, TJ, TM), European (AL, AT, BE, BG, CH, CY, CZ, DE, DK, EE, ES, FI, FR, GB, GR, HR, HU, IE, IS, IT, LT, LU, LV, MC, MK, MT, NL, NO, PL, PT, RO, RS, SE, SI, SK, SM, TR), OAPI (BF, BJ, CF, CG, CI, CM, GA, GN, GQ, GW, KM, ML, MR, NE, SN, TD, TG).

Published:

— with international search report (Art. 21(3))

(54) Title: POWER MANAGER WITH RECONFIGURABLE POWER CONVERTING CIRCUITS

(57) Abstract: A reconfigurable power circuit (400) includes a single one-way DC to DC power converter (220, 221). The reconfigurable power circuit is configurable by a digital data processor as one of three different power channels (230, 232, and 234). Power channel (230) provides output power conversion. Power channel (232) provides input power conversion. Power channel (234) provides bi-directional power exchange without power conversion.

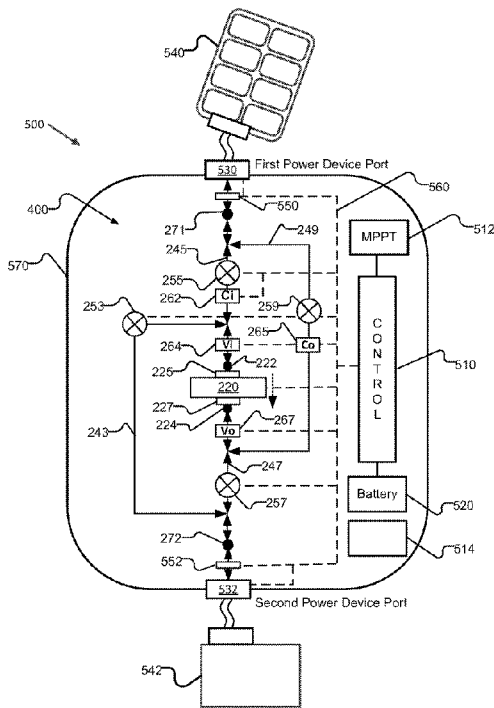

Figure 11

WO 2020/236623 A1

POWER MANAGER WITH RECONFIGURABLE POWER CONVERTING CIRCUITS

[0001]

[0002]

[0003]

[0004] **Background of the Invention**

[0005] **Field of the Invention**

[0006] The exemplary, illustrative, technology herein relates to a reconfigurable converter power circuit. The reconfigurable converter power circuit includes a single one-way DC to DC power converter, multiple converter channel legs, and multiple switches. The reconfigurable converter power circuit can be configured as one of an input power converting channel, and output power converting channel, or a bi-directional bus-compatible power channel by configuring sets of the multiple switches as either open or closed. A power manager includes at least one reconfigurable power circuit connected to a device port and connected to a power bus. The reconfigurable converter power circuit can be configured to connect the device port to the power bus. The reconfigurable converter power circuit can be reconfigured for three different functions: input power signal voltage conversion, output power signal voltage conversion, and input or output power signal with no voltage conversion. A power node includes a first power device port and second power device port and a reconfigurable converter power circuit connected to the first power device port and to the second power device port. The reconfigurable converter power circuit can

be configured to connect the first and second power device ports. The reconfigurable converter power circuit can be reconfigured for three different functions: first power device port to second power device port signal voltage conversion, second power device port to first power device port signal voltage conversion, and no voltage conversion between first power device port and second power device port.

[0007] **The Related Art**

[0008] Portable power manager devices are used to scavenge DC power from external power devices, i.e. DC power sources and energy storage devices such as rechargeable DC batteries. The scavenged power received from external DC power and energy sources is used to power a power bus operating on the portable power manager. External power devices that need power, i.e. DC power loads and or energy storage devices such as rechargeable DC batteries are interfaced to the power bus to draw power from the power bus.

[0009] Conventional power managers include a plurality of device ports connected to an internal DC power bus. An external DC power device is connected to a device port. Typically each device port includes a direct connect power channel usable to directly connect an external power device connected to a device port to the power bus without voltage conversion. In conventional power managers direct connect power channels include a switch, operable by a digital processor operating on the power manager, to directly connect an external DC power device to the power bus or to disconnect the external power device from the power bus.

[0010] Conventional portable power manager devices use a fixed bus voltage selected to match the operating voltage of most of the external DC power devices that will be powered by or recharged by the power manager. Thus when the power manager is expected to be used to power 12VDC devices its bus voltage operating range might be set at 12 to 15VDC. Thus whenever an external DC power device has an operating voltage that is matched to the bus voltage, that external power device can be connected to the DC power bus over the direct connect power channel as long as other criteria favor the connection. Thus each device port includes a direct connect power channel which is bidirectional and can be used to receive input power from an external power device or to deliver output power to an external power device as long as the external power device is compatible with the bus voltage.

[0011] In conventional portable power managers each device port also may be associated with a power converting power channel that includes either an input DC to DC power converter or an output DC to DC power converter and at least one switch operable by the digital processor operating on the power manager to connect an external DC power device to the power bus over the power converter channel or to disconnect the external DC power device from the power bus or to prevent the connection as needed. In cases where an external DC power device is a non-bus compatible DC power or energy source usable to scavenge input power; the external device is connected to the power bus over a power converting channel that includes an input power converter. In cases where an external DC power device is a non-bus compatible DC power load or rechargeable energy storage device that needs to be powered, the external device is connected to the power bus over an output power DC to DC converter.

[0012] Examples of conventional portable power managers are disclosed in U.S. Pat. No.'s 8,775,846, entitled Portable Power Manager; 8,638,011, entitled Portable Power Manager Operating Methods; and 8,633,619, entitled Power Managers and Methods for Operating Power Managers all to Robinson et al. describing portable power manager devices and operating methods. In these examples the power manager devices include six device ports that can each be connected to a power bus or disconnected from the power bus by operating switches under the control of a digital process or CPU. The power bus operates at a fixed bus voltage which can vary slightly over a range. All six device ports include a direct connect bidirectional power channel that extends from the power bus to the device port. Each direct connect power channel includes a switch operable by the digital processor. Thus any one of the six device ports can be connected to the power bus over a direct connect power channel when an external power device connected to the device port is a bus voltage compatible device and this includes any DC power source, DC power load, or rechargeable battery that can be operated at the bus compatible voltage.

[0013] The device disclosed by Robinson et al. includes a total of three DC to DC power converters with one power converter arranged as an input power converter and two power converters arranged as output power converters. More specifically the input power converter is shared by two input ports and each of the two output power converters is shared by two output ports. One problem with this configuration is that while there are six device ports only three of the

six device ports can use one of the three DC to DC power converters at the same time. More specifically only one input device port can be connected to the power bus over an input power converting channel and only two output device ports can be connected to the power bus over an output power converting channel at the same time. In practice this can result in situations where only three device ports or at least less than all six device ports can be utilized.

[0014] This problem can be solved by providing an input power converting channel and an output power converting channel between each device port and the power bus; however, such a device is more costly and increases the weight and device package size. Meanwhile there is a need in the art to decrease the cost weight and package size of conventional portable power managers.

[0015] Another problem with conventional portable power managers that use a fixed bus voltage is that the fixed power manager bus voltage tends to limit the type of external DC power devices that it can be used with. Specifically a portable power manager having a fixed 12VDC bus voltage is best suited to scavenge power for external power devices that operate at 12VDC. However, for the reasons stated above, the same conventional portable power manager is not as effective in an environment where most external power devices that need to be powered by the power bus operate at 48VDC. Thus there is a need in the art to provide a power manager that can operate at different bus voltages depending in part on the operating voltage of external DC power devices that need to be connected to the power bus.

[0016] **Summary of the Invention**

[0017] The problems with conventional power managers described above are overcome by the present invention which includes a novel power manager configuration and operating methods.

[0018] A reconfigurable power circuit (400) includes a first electrical connection interface (271) and a second electrical connection interface (272). A one-way DC to DC power converter (220) includes an input terminal (222) for receiving input power at a first power amplitude and an output terminal (224) for delivering output power at a second power amplitude. A plurality of converter channel legs (243, 245, 247, and 249) is arranged as three different conductive pathways including a first bidirectional current flow path (234, 400a) that extends from the first electrical connection interface to the second electrical connection interface. In one embodiment the first bidirectional current flow path (234) does not pass through the DC to DC power converter and does

not charge input and output bulk capacitors (225, 226). In another embodiment, the first bidirectional current flow path (400a) passes through the one-way DC to DC power converter from the input terminal thereof to the output terminal thereof while the DC to DC power converter is configured with a zero-voltage conversion set point. The first bidirectional current flow path (400a) also charges input and output bulk capacitors.

[0019] A second, one-way current flow path (232) extends from the first electrical connection interface to the input terminal (222) through the one-way DC to DC power converter (220) to the output terminal (224) and from the output terminal to the second electrical connection interface. A third one-way current flow path (230) extending from the second electrical connection interface to the input terminal (222) through the one-way DC to DC power converter (220) to the output terminal (224) and from the output terminal to the first electrical connection interface.

[0020] At least one configurable switch disposed along each one of the plurality of converter channel legs. Closing one or more of the configurable switches and opening one or more others of the configurable switches enables exclusive current flow along one of the first bidirectional current flow path (234., 400a), the second, one-way current flow path (232), and the third one-way current flow path (230). The reconfigurable power circuit includes four channel legs (243, 245, 247, and 249) with one configurable switch (253, 255, 257, and 259) disposed along each channel leg. Exclusive current flow any one of the first bidirectional current flow path (234), the second, one-way current flow path (232) or the third one-way current flow path (230) can be established by closing at two or three of the four configurable switches and by opening two or one other of the four configurable switches.

[0021] The reconfigurable power circuit includes one or more input current sensors (262) and or one or more input voltage sensors (264) for measuring input current or voltage amplitude at either side or the input interface (222) or the output interface (224) or at either one of the first electrical and second electrical connection interface points. The reconfigurable power circuit includes one or more output current sensors (265) and or one or more output voltage sensors (267) for measuring input voltage amplitude or output voltage amplitude at either side or the input interface (222) or the output interface (224) or at either one of the first electrical and second electrical connection interface points.

[0022] The reconfigurable power circuit can be included in a power manager device (500, 1000) configured with one or both of first electrical connection interface (271) and the second electrical connection interface (272) as a device port and operated to exchange power between two external DC power devices each connected to a different one of the device ports. Alternately, the first electrical connection interface (271) is configured as a device port and the second electrical connection interface (272) electrically interfaced with a DC power bus (110). In an embodiment a plurality of reconfigurable power circuits is interfaced with a DC power bus at second electrical interface and the first electrical interface of each of the plurality of reconfigurable power circuits is configured as a device port. In operation, DC power is exchanged between external DC power device interfaced with the device ports and the DC power bus. A primary device channel (153) is electrically interfaced with the DC power bus. The primary device channel is a bidirectional non power converting channel. A primary device port (143) electrically interfaced with the primary device channel.

[0023] The one-way DC to DC power converter (220) is operable by an electronic controller to receive input power at a first input power voltage amplitude at the input terminal (222) and deliver output power from the output terminal (224) at second output voltage amplitude, different from the first input voltage amplitude. Alterably the one-way DC to DC power converter is operable by the electronic controller to receive input power at a first input current amplitude at the input terminal (222) and deliver output power from the output terminal (224) at second output current amplitude, wherein the second output current amplitude is less than the first input current amplitude.

[0024] A power distribution system (1000) includes a DC power bus (110) and a plurality of the reconfigurable power circuits (400a, 400b). The first electrical connection interface (271) of each of the plurality of reconfigurable power circuits is configured as a first device port (141, 142) and the second electrical connection interface (272) of each of the plurality of the reconfigurable power circuits is interfaced with a DC power bus (110). A primary device channel (153) has a first end thereof terminated by a primary device port (143) and a second end thereof electrically interfaced with the DC power bus with a configurable switch (261) disposed along the primary device channel. A digital data processor (120) is electrically interfaced with a memory module,

with each of the device ports (141, 142, 143) and with all of the controllable switches corresponding with all of the reconfigurable power circuits. The digital data processor is also electrically interfaced with the one-way DC to DC power converter of each of the plurality of reconfigurable power circuits. At least one sensor is electrically interfaced with the digital data processor and is positioned to measure one of an instantaneous input power amplitude and an instantaneous output power amplitude either at the DC power bus or corresponding with measurement points corresponding with any of the plurality of reconfigurable circuits. An energy management schema program is operated on the digital data processor. The system operates to autonomously exchange power between at least two external DC power devices electrically interfaced with any one of the first device port (141, 142) and the primary device port (143).

[0025] A Maximum Power Point Tracking (MPPT) module (512) can be operated by the digital data processor to manage input power from a time variable voltage source such as a solar or wind power generation device. The MPPT module operates to provide current attenuation and voltage conversion set points to the one way DC to DC power converter to converts variable voltage input power to substantially non-variable voltage output power.

[0026] An operating method for the reconfigurable circuit for a single reconfigurable circuit that include a device port at each electrical interface point includes evaluating, by the energy management schema, DC power characteristics electrical interface points. The method may use measuring a power condition by one or more sensors or receiving power characteristics data from one or more of the two external DC power devices. The method includes selecting, by the energy management schema, based on the DC power characteristic evaluation, one external DC power device as a power source and another external DC power device as a power load. The energy management schema then determines, based on the DC power characteristic evaluation, a DC to DC voltage conversion setting for operating the one-way DC to DC power converter and selects a configuration of the reconfigurable power circuit that corresponds with the DC to DC voltage conversion setting. The configuration of the reconfigurable power circuit includes any one of the first bidirectional current flow path between the device ports, the second, one-way current flow path extending from the first device port to an input terminal of the one-way DC to DC power converter through the one-way DC to DC power converter to an output terminal of the one-way DC

to DC power converter to the second device port or the third one-way current flow path extending from the second device port to the input terminal through the one-way DC to DC power converter to the output terminal and from the output terminal to the first device port.

[0027] These and other aspects and advantages will become apparent when the Description below is read in conjunction with the accompanying Drawings.

[0028] **Brief Description of the Drawings**

[0029] The features of the present invention will best be understood from a detailed description of the invention and example embodiments thereof selected for the purposes of illustration and shown in the accompanying drawings in which:

[0030] Figure 1 depicts an exemplary schematic diagram of a non-limiting exemplary power manager according to one aspect of the present invention.

[0031] Figure 2 depicts a perspective view of a non-limiting exemplary power manager according to one aspect of the present invention.

[0032] Figure 3 depicts a perspective view of a non-limiting exemplary cable assembly according to one aspect of the present invention.

[0033] Figure 4 depicts an exemplary schematic diagram of a non-limiting exemplary power manager according to one aspect of the present invention.

[0034] Figure 5 depicts an exemplary schematic diagram of a non-limiting exemplary power manager according to one aspect of the present invention.

[0035] Figure 6 depicts an exemplary schematic diagram of a non-limiting exemplary power manager according to one aspect of the present invention.

[0036] Figure 7 depicts an exemplary schematic diagram of a non-limiting exemplary power manager according to one aspect of the present invention.

[0037] Figure 8 depicts an exemplary flow diagram depicting a non-limiting exemplary power manager operating mode according to one aspect of the present invention.

[0038] Figure 9a depicts an exemplary schematic diagram of a non-limiting exemplary reconfigurable power converter circuit according to one aspect of the present invention.

[0039] Figure 9b depicts an alternative exemplary schematic diagram of a non-limiting exemplary reconfigurable power converter circuit according to one aspect of the present invention.

[0040] Figure 10 depicts an exemplary schematic diagram of a non-limiting exemplary power manager that includes two reconfigurable power converting circuits according to the present invention.

[0041] Figure 11 depicts an exemplary schematic diagram of a non-limiting exemplary power node according to one aspect of the present invention.

[0042] **Description of Some Embodiments of the Invention**

[0043] **Definitions**

[0044] The following definitions are used throughout, unless specifically indicated otherwise:

TERM	DEFINITION
External Power Device	A DC power load, a DC power source, or a re-chargeable DC battery.
Energy Management Schema	An energy management schema includes various programs, firmware algorithms, and policy elements operating on a digital data processor to receive input power into a power manager from one or more device ports and to distribute output to external power devices connected to one or more device ports.

Item Number List

[0045] The following item numbers are used throughout, unless specifically indicated otherwise.

#	DESCRIPTION	#	DESCRIPTION
100	Power manager	247	Converter channel leg
110	DC power bus	247a	Converter channel leg
112	Power bus power sensor module	247b	Converter channel leg
114	Network communication interface device	249	Converter channel leg
116	Internal battery	249a	Converter channel leg
120	Digital data processor	249b	Converter channel leg
122	Memory module	251	Primary leg
130	Communication channel	253	First configurable switch
141	First converter device port	253a	First configurable switch
142	Second converter device port	253b	First configurable switch
143	Primary device port	255	Second configurable switch
151	First reconfigurable converter	255a	Second configurable switch

	power circuit		
152	Second reconfigurable converter power circuit	255b	Second configurable switch
153	Primary power channel	257	Third configurable switch
161	Secondary external DC power device	257a	Third configurable switch
162	Secondary external DC power device	257b	Third configurable switch
163	Primary external DC power device	259	Fourth configurable switch
170	Power manger enclosure	259a	Fourth configurable switch
172	Enclosure side wall	259b	Fourth configurable switch
174	Enclosure top wall	261	Primary configurable switch
176	Physical connector	262	Input current sensor module
177	Physical connector	262a	Input current sensor module
178	Physical connector	262b	Input current sensor module
180	Shielded cable	264	Input voltage sensor module
181	Distal end of cable	264a	Input voltage sensor module
183	Proximal end of cable	264b	Input voltage sensor module
184	Cable gland	265	Output current sensor module
186	Cable conductive elements	265a	Output current sensor module
		265b	Output current sensor module
200	Power manager enclosure	267	Output voltage sensor module
210	Converter circuit power sensor module	267a	Output voltage sensor module
211	Converter circuit power sensor module	267b	Output voltage sensor module
212	Primary channel power sensing module	271	First electrical connection interface
220, 221	One-way DC to DC power converter	271a	First electrical connection interface
222	Power converter input terminal	271b	First electrical connection interface
222a	Power converter input terminal	272	Second electrical connection interface
222b	Power converter input terminal	272a	Second electrical connection interface
224	Power converter output terminal	272b	Second electrical connection interface
224a	Power converter output terminal		
224b	Power converter output terminal	300	Wire assembly
225	Input bulk capacitor		
225a	Input bulk capacitor	400	Reconfigurable power circuit

225b	Input bulk capacitor	400a	Reconfigurable power circuit
227	Output bulk capacitor	400b	Reconfigurable power circuit
227a	Output bulk capacitor	401	Reconfigurable power circuit
227b	Output bulk capacitor		
230	Power converting output power channel	500	Power node
231	Power converting output conductive pathway	510	Electronic controller
232	Power converting input power channel	512	(MPPT) module
233	Power converting input conductive pathway	514	Communication interface device
234	Bus compatible power channel	520	Battery
235	Bus compatible conductive pathway	530	First power device port
243	Converter channel leg	532	Second power device port
243a	Converter channel leg	540	First power device
243b	Converter channel leg	542	Second power device
245	Converter channel leg	550	First device port power sensor module
245a	Converter channel leg	552	Second device port power sensor module
245b	Converter channel leg	560	Power node communication channel
		570	Power node enclosure

[0046] Exemplary System Architecture

[0047] Referring to Figure 1, an exemplary, non-limiting power manager (100) according to the present invention is shown in schematic view. The power manager (100) includes a digital data processor (120) and an associated memory module (122). The digital data processor (120) includes a programmable logic device operating an energy management schema program and carrying out logical operations such as communicating with external DC power devices (161, 162, 163), connected to device ports (141, 142, 143), managing the memory module (122) to store and recall data, reading sensor signals from power sensors, altering an operating voltage of a DC power bus (110), and operating one or more reconfigurable power circuits and related power channel control devices to establish a power network operable to exchange power from one external DC power device to another.

[0048] Variable voltage DC power bus

[0049] Power manager (100) includes a variable voltage DC power bus (110). An operating voltage of the DC power bus (110) can be set by the digital data processor (120). In an example operating mode, the operating voltage of the DC power bus (110) is matched to an operating voltage of an external DC power device (163) interfaced with a primary device port (143). The primary device port (143) is connected to the power bus (110) over a primary power channel that does not include a power converter. Accordingly the operating voltage of the primary external DC power device (163) is always used to establish the operating voltage of the DC power bus (110).

[0050] Power manager (100) includes a bus power sensor module (112) in electrical communication with DC power bus (110) and in communication digital data processor (120) and operable to measure and report instantaneous DC voltage at the DC power bus (110) to the digital data processor (120). Bus power sensor module (112) may determine one or more of instantaneous power, instantaneous voltage, and/or instantaneous current amplitude at the DC power bus (110).

[0051] Device ports

[0052] The power manager (100) described below includes three device ports; however, any practical implementation that includes two or more device ports is within the scope of the present invention. In each embodiment, the power manager includes a single primary device port (143) and one or more secondary device ports (141, 142). Each device port provides a wired electrical connection interface over which an external DC power device (161, 162, and 163) can be electrically interfaced to the power manager by a wire connection that at least includes a power channel. Each device port (141, 142, 143) also includes a communication channel or interface such as SMBus or the like operable to provide a digital communication link between the digital data processor (120), and an external DC power device electrically interfaced with each device port. Each device port (141, 142, and 143) includes a power channel operable to exchange a power signal between the DC power bus (110) and an external DC power device electrically interfaced to the device port. The communication channel can be a wired communication channel or a wireless communication channel. Also the power channel may include an inductive portion for power exchange from the device port to an external DC power device across a none-wire medium.

[0053] **Cable gland**

[0054] Referring to Figures 1-3 in an exemplary, non-limiting, embodiment power manager (200) includes a sealed and substantially weather and dust tight power manager device enclosure (170) including a plurality of enclosure side walls (172) an enclosure top wall (174) and an opposing enclosure bottom wall opposed to the top wall (174). The enclosure (170) encloses components of the power manager (100) including the digital data processor (120), the DC power bus (110), and the power circuits and channels (151, 152, and 153). In a non-limiting embodiment, the device ports (141, 142, and 143) are connected to distal ends (181) of wire cables (180) that pass through the enclosure side walls (172) at a proximal end.

[0055] In a preferred embodiment each device port comprises a first physical connector or plug (176, 177, and 178) suitable for connecting to an external power device connected to the distal end (181) of wire or cable (180). Each first physical connector or plug is suitable for mating with any external DC power device having a comparable second physical connector or plug. In a preferred embodiment external DC power devices are easily connected to or disconnected from any one of the first physical connectors to electrically interface with the power manager.

[0056] Referring to Figure 3 which depicts a wire assembly (300), each device port includes a cable gland (184) passing through one of the enclosure side walls (172). The wire cables (180) each preferably comprise a shielded cable wherein a proximal end (183) of each wire cable passes through a different cable gland (184) and a distal end (181) of each the wire cables is terminated by a first physical connector (176, 177, and 178). Each cable gland (184) passes through an aperture passing through an enclosure side wall (172) and is attached to and mechanically supported by the enclosure side wall (172). Each wire cable (180) includes conductive elements (186) enclosed by a cable shielding layer which is further enclosed by an electrically insulating cable outer covering. Some of the conductive elements (186) at the proximate end of each wire cable are electrically interfaced with one of the power channels (151, 152, and 153) which provide a conductive path to the DC power bus (110). Some of the conductive elements (186) at the proximal end of each wire cable may be electrically interfaced with one of the communication channels (130). The conductive elements (186) at the distal end (181) of each wire cable are electrically interfaced with a different first physical connector (141,

142, and 143) which includes one or more power channels and may include one or more wired communication channels. Each cable (180) enters the cable gland (183) from outside the enclosure side wall (172) and the cable shielding layer and the electrically insulating cable outer covering the shielding layer are gripped by the cable gland (184) in a manner that electrically grounds the cable shielding layer to a corresponding enclosure sidewall (172) and secures the distal end to the cable gland. A similar cable gland (184), cable and enclosure wall interface is disclosed in commonly owned U.S. Patent Application No. 15/081461 entitled Cable Gland Assembly by Long et al. filed on 03/25/2016.

[0057] Communication network

[0058] Referring now to Figure 1 the power manager (100) includes a communication network (130). The communication channel (130) includes one or more network or similar communication interface devices (114) and a plurality of communication channels interconnecting various internal devices and modules to the digital data processor (120) for digital communication. The communication channel (130) optionally includes additional network communication interface devices (114) operable to communicate with other power managers, e.g. over a peer-to-peer network, as well as to gain access to a Wide Area Network (WAN), e.g. over a cellular network interface device, and or to communicate with WAN based devices such a policy server, authentication module or the like, operating on one or more WAN based servers. Each wireless network interface device (114) is configured to receive communication signals configured in a first communication protocol structure and to translate the first communication protocol signals to a second communication protocol structure as needed to facilitate communication between devices configured to use different communication protocols. The communication channels also may extend between internal modules of the power manager (100) without passing over the digital data processor (120) and may include analog channels for exchanging analog signals including power signals. Each device port (141, 142, and 143) is connected with the digital data processor (120) over at least one communication network channel. Accordingly when an external power device is connected with any one of the device ports the external DC power device joins the communication network established by the communication interface device (114) for communication with the digital data processor (120).

[0059] The communication channel (130) optionally includes a variety of communication channel types, e.g. using different network protocols, suitable for digital data communications. The communication channel types may include analog signal conductors or the like for exchanging analog signals between electronic modules operating on the power manager (100). The communication channel (130) is primarily a wired communication network housed inside the enclosure (170). Wireless communication channels are optionally provided such that in some embodiment's wireless communication channels are usable to communicate with external DC power devices or with other power managers and with network devices reachable on a Wide Area Network (WAN).

[0060] The various communication channel types may include one or more of a wired network using a wire network communication protocol, e.g. the IEEE 802.3 wired Local Area Networks (LAN) protocols which include Ethernet and Power over Ethernet (PoE), System Management Bus (SMBus), Universal Serial Bus (USB), Recommended Standard 232 (RS232), or the like. The various communication channel types may include wireless networks based on any one of the IEEE 802.11 Wireless Local Area Network (WLAN) protocols which include Wi-Fi, Bluetooth, or any one of the IEEE 802.11 WLAN protocols, and one or more cellular network protocols e.g. 3G, 4G, LTE, etc.

[0061] Additionally, the communication channel (130) may include conductive paths, wires or the like, for exchanging analog or digital signals between electronic components of the power manager such as various switches, sensors, and power converters and the digital data processor (120). In particular, the communication channel (130) extends from the digital data processor (120) to each controllable element of the power manager (100) including switching elements (253, 255, 257, 259, 261), the DC power bus sensor (112), other power sensors (210, 211, and 212) and power converters (220, 221) to deliver control signals thereto and to receive sensor signals, or the like, therefrom. The control signals include configuration and setting instructions for operating each controllable element to receive and distribute power according to the energy management schema. The communication channels extending to device ports may comprise a one-wire identification interface configured to enable the digital data processor (120) to query a connected external power device (161, 162, and 163) for power characteristics information.

[0062] Power manager battery

[0063] The power manager (100) includes an optional internal rechargeable battery (116). If present, the internal battery (116) provides power to the digital data processor (120). The internal battery is a rechargeable battery (116) that can be charged when the power manager (100) is operably connected to a power source or external battery capable of providing charge. The internal battery (116) provides power to digital data processor (120), enabling the functioning of the power manager (100), when power sufficient for operation of the power manager is not available from a power source or rechargeable battery connected to a device port (161, 162, 163).

[0064] Alternatively, power sensors (210, 212) are operable to detect an operating voltage and or input power available from a connected external power source or rechargeable DC battery without any communication with the external device and to use the available input power to operate the digital data processor (120) or recharge the internal battery (116).

[0065] Primary power channel

[0066] Referring now to Figures 1 and 4, power manager (100) includes a primary device port (143) which is electrically connectable to a primary external DC power device (163) and a DC power bus (110). The primary external DC power device (163) is any external DC power device that can be connected to any one of the primary device port (143) or the secondary device ports (141) or (142). The primary power channel (153) includes only one power channel extending from the primary device port (143) to the DC power bus (110) and is configurable as a bi-directional power channel operable as an input power channel or as an output power channel without voltage or power conversion and without current attenuation.

[0067] Primary power channel (153) includes a bidirectional conductor or primary leg (251) that extends between primary device port (143) and DC power bus (110) and allows current flow either from the primary external DC power device (163) to the DC power bus (110) or from the DC power bus (110) to the primary external DC power device (163). A primary configurable switch (261) is disposed along primary leg (251) between the primary device port (143) and DC power bus (110). Digital data processor (120) is in communication with primary configurable switch (261) over the communication channel (130) and is operable to send control signals to the primary configurable switch (261). Digital data processor (120) can set primary configurable

switch (261) in an open position to block flow of current over the primary leg (251) or in a closed position to allow an input power signal to pass from primary device port (143) to DC power bus (110) or to allow an output power signal to pass from power bus (110) to the primary external DC power device (163) over the primary device port (110), thereby connecting primary external DC power device (163) to DC power bus (110).

[0068] Primary power channel (153) optionally includes a primary channel power sensor module (212) associated with primary device port (143) and in communication with digital data processor (120) over the communication channel (130). The primary channel power sensor module (212) is configured to measure power characteristics of power signals passing over the primary power channel (153) including one or more of instantaneous power amplitude, instantaneous voltage amplitude, and instantaneous current amplitude and to report amplitude measurement results to digital data processor (120).

[0069] Reconfigurable converter power circuit

[0070] Referring now to Figures 1 and 4-7 the power manager (100) further includes at least one and in the present embodiment two converter or secondary device ports (141, 142) each of which is electrically connectable to a secondary external DC power device (161, 162). Each secondary external DC power device (161, 162) is any external DC power device that can be connected to any one of the primary device port (143) or the secondary device ports (141) or (142). Each reconfigurable power circuit (151, 152) extends between a different converter or device port (141, 142) and the DC power bus (110). Each reconfigurable power circuit (151, 152) is independently operated by the digital data processor (120) as needed to transfer power between a connected secondary external DC power device (161, 162) and the DC power bus (110) or to transfer power from the DC power bus (110) to the connected secondary external DC power device (161, 162). Each converter device port (141, 142) includes a communication channel, operably connectable to an external secondary DC power device (161, 162) interfaced therewith. The communication channel is part of the communication channel (130), which enables communications between the digital data processor (120) and each of the secondary external DC power device (161, 162) interfaced with a converter device port (141, 142).

[0071] The reconfigurable converter power circuits (151, 152) each include one or more secondary power channels or conductors that extends from a different converter or secondary device port (141, 142) to the DC power bus (110). Each secondary power channel includes a different one-way DC to DC power converter (220, 221) disposed between a corresponding device port and the DC power bus. Each reconfigurable converter power circuit (151, 152) includes power channel circuitry that is configurable to provide any one of a one-way power converting input power channel (232), shown in Figure 6, a one-way power converting output power channel (230), shown in Figure 5, and a bidirectional power channel (234), shown in Figure 7 wherein the bidirectional power channel (234) is usable as an input power channel or an output power channel without voltage conversion.

[0072] Each reconfigurable converter power channel (151, 152) includes a different converter circuit power sensor module (210, 211). Each converter circuit power sensor module is disposed proximate to a corresponding converter device port (141, 142) in order to sense power characteristic of power signals either entering or exiting the converter device port (141, 142). Each converter circuit power sensor module is in communication with the digital data processor (120) and is operable to measure power characteristics of a bidirectional power signal including one or more of instantaneous power, instantaneous voltage, and instantaneous current and to report measurement results to the digital data processor (120).

[0073] Each controllable one-way DC to DC voltage or power converter (220, 221) includes an input terminal (222) and an output terminal (224). Each DC to DC power converter (220, 221) is one-way because a power signal can only be power converted or current modulated when the power signal is directed from the input terminal (222) to the output terminal (224). Specifically, a power signal entering through the input terminal (222) is power converted and or current modulated according to power conversion and amplitude modulation settings received from the digital data processor (120). The power converted output signal exiting output terminal (224) has one of a different voltage or a different current amplitude, or both and may have a different total power amplitude as compared to the input power signal.

[0074] The DC to DC power converter (220) can be configured to convert in input signal voltage to a different output signal voltage by either stepping the input voltage up or stepping the

input voltage down as required to adjust the output signal voltage exiting from the output terminal (224) to a desired voltage amplitude. Optionally the DC to DC power converter is further configured to modulate the current amplitude of the input power signal as required to adjust the output signal current amplitude exiting from the output terminal (224) to a desired current amplitude. Generally the power converter operates to modulate current amplitude passing over the power converter between substantially zero and a maximum available current amplitude, i.e. the entire instantaneous current amplitude of the input signal is passed through the power converter without modulation.

[0075] In an exemplary operating mode, the digital data processor (120) determines if an external DC power device connected to a converter or secondary device port (161, 162) is a DC power source, a rechargeable DC battery, or a DC power load, either by communicating with the external DC power device to determine a device type and other information such as the operating voltage range, state of charge, or the like, or by determining an instantaneous voltage based on a sensor signal received from the converter circuit power sensor module (210). Once the device type and voltage requirements of the device are determined the energy management schema operating on the digital data processor makes a determination about whether to connect the external power device to the DC power bus or not and further makes a determination about how to configure the relevant reconfigurable circuit (151, 152) to make the connection.

[0076] Each reconfigurable converter power circuit (151, 152) includes four configurable switches (253), (255), (257), and (259). Each configurable switch is operable to direct a power signal over a desired conductive flow path or to prevent the power signal from flowing over the conductive flow path. Digital data processor (120) is in communication with each of the four configurable switches via the communication channel (130) and is operable to send an independent control signal to each switch. Each configurable switch (253, 255, 257, and 259) can be toggled to an open (off) position, to prevent current flow across the switch or toggled to a closed (on) position to allow current flow across the switch. Similarly the configurable switch (261) used in the primary power channel (153) can be toggled to an open (off) position, to prevent current flow across the switch or toggled to a closed (on) position to allow current flow across the switch.

[0077] In an exemplary embodiment, configurable switches (253, 255, 257, and 259) of the reconfigurable power circuits (251, 253) and the configurable switch (261) of the primary power channel (153) are single pole single throw type switches. Alternatively, the switches can be implemented with multiple throws, multiple poles. The switches can include Field Effect Transistors (FETs), e.g. MOSFETs, Power FETs, e-MOSFETs, etc.

[0078] Referring to Figures 4 – 7, each reconfigurable converter power circuit (151, 152) includes multiple power channels (230, 232, and 234) each comprising multiple converter channel legs (243, 245, 247, and 249). As shown in the Figures, bidirectional current flow over each leg is indicated by solid double-headed arrows, e.g. as shown on the primary power channel (153) and one-way current flow over each leg is indicated by solid single headed arrows, e.g. as shown on converter power circuit (230). Converter device port (141, 142), DC power bus (110), switches (253, 255, 257, and 259) and one-way DC to DC power converter (220) are interconnected by the converter channel legs (243, 245, 247, and 249) to provide various current flow paths or circuit configurations as may be required to distribute power to or receive power from an external converter power device connected to a secondary device port.

[0079] Reconfigurable converter power circuits (151, 152) are configurable to transfer power signals between converter or secondary device ports (141, 142) and the DC power bus (110) in either direction i.e., from converter device port (141, 142) to DC power bus (110) or from DC power bus (110) to converter device port (141, 142) with or without power conversion by configuring the state of each of the configurable switches (253, 255, 257, and 259) in patterns of open and closed positions and by configuring the state of each DC to DC power converter (120) for power converting or non-power converting modes. Patterns of open and closed positions and of on and off configurations are set forth in Table 1.

[0080] Referring to Figures 5, 6, and 7, patterns of configurable switch open and closed positions, power converter on and off configurations, and corresponding electrical current flow paths are shown for each of the multiple power channels (230, 232, and 234). Blackened circles represent closed switches, bolded power converter (220) outlines represent “on” state of the power converter, and bolded arrows represent active converter channel legs, i.e. channel legs over which

electrical current can flow given the specified patterns of open and closed switch positions and power converter setting.

[0081] Primary power channel (153) is configured as an input/output power channel by closing primary configurable switch (261). In this case an input power signal received from a primary external DC power source or rechargeable battery connected to the primary device port (143) is directed to the DC power bus (110) without power conversion. Likewise when a primary external power load or rechargeable DC battery to be charged is connected to primary device port (143) an output power signal received from the DC power bus (110) is directed to primary device port (143) without power conversion.

[0082] Referring now to Figure 5, each reconfigurable converter power circuit (151, 152) can be configured as a power converting output power channel (230) comprising power converting output conductive pathway (231) by opening switches (255) and (257), closing switches (253) and (259), and configuring the one-way DC to DC power converter (220) for the required power conversion. In this case an output power signal received from the DC power bus (110) is directed to the input terminal (222) of DC to DC power converter (220). The DC to DC power converter is configured to perform whatever voltage conversion is required to convert the output power signal to a voltage that is compatible with powering whatever secondary external DC power device is connected to the corresponding secondary device port (141, 142). Additionally if needed, the DC to DC power converter (220) can be operated to modulate current amplitude of the output power signal being voltage converted. The power converted output power signal is directed from the output terminal (224) of the DC to DC power converter (220) to converter device port (141, 142). In this configuration, power characteristics of the output power signal are monitored by the converter circuit power sensor module (210) and the power characteristics at the DC power bus (110) are monitored by the power bus sensor module (112).

[0083] Referring now to Figure 6, each reconfigurable converter power circuit (151, 152) can be configured as a power converting input power channel (232), comprising power converting input conductive pathway (233), by closing switches (255) and (257), opening switches (253) and (259), and configuring the DC to DC power converter (220) to make the necessary voltage conversion. In this case an input power signal received from a secondary external DC power source

or rechargeable battery connected to one of the device port (141, 142) is directed to the input terminal (222) of the DC to DC power converter (220). The DC to DC power converter is configured to perform whatever voltage conversion is required to convert the input power signal to a bus compatible voltage and the converted input power signal is passed to the DC power bus (110). Additionally, if needed, the DC to DC power converter (220) can be operated to modulate the current amplitude of the input power signal being voltage converted. The power converted input power signal is delivered from the output terminal (224) to DC power bus (110). In this configuration, power characteristics of the input power signal are monitored by the converter circuit power sensor module (210) and the power characteristics at the DC power bus (110) are monitored by the power bus sensor module (112).

[0084] Referring now to Figure 7, each reconfigurable converter power circuit (151, 152) can be configured to a bus-compatible power channel (234), comprising bus-compatible conductive pathway (235), by opening switches (257) and (259), closing switches (253) and (255), and turning off one-way DC to DC power converter (220). In this configuration the power channel (234) is bi-directional such that any external power device that has a bus compatible operating voltage can be connected to the DC power bus (110) without power conversion. In the case where the secondary power device connected to a secondary device port is an external DC power source or a rechargeable DC battery having available charged stored thereon, an input power signal can be directed to the DC power bus (110) without power conversion. Conversely when the secondary power device connected to a secondary device port is an external DC power load or rechargeable battery than can accept charging power, an output power signal can be directed from the DC power bus (110) to the connected external power device without power conversion.

[0085] Table 1 includes configuration of the configurable switches and of DC to DC power converter (220) corresponding with the three configurations of the reconfigurable converter power circuits (151, 152) described above.

Table 1

Reconfigurable converter power circuit (151, 152) power channel configuration	Power control element	Configuration
Power converting output power channel (230) (Figure 5)	Switch 1 (255)	Open
	Switch 2 (253)	Closed
	Switch 3 (259)	Closed
	Switch 4 (257)	Open
	Power converter (220)	On
Power converting input power channel (232) (Figure 6)	Switch 1 (255)	Closed
	Switch 2 (253)	Open
	Switch 3 (259)	Open
	Switch 4 (257)	Closed
	Power converter (220)	On
Bus compatible power channel (234) Figure (7)	Switch 1 (255)	Closed
	Switch 2 (253)	Closed
	Switch 3 (259)	Open
	Switch 4 (257)	Open
	Power converter (220)	Off
Initial State	Switch 1 (255)	Open
	Switch 2 (253)	Open
	Switch 3 (259)	Open
	Switch 4 (257)	Open
	Power converter (220)	Off

[0086] External power devices

[0087] External DC power devices can be connected to any one of the device ports described above. An external DC power device includes a primary external DC power device (163) interfaced with primary device port (143) and one or more secondary external DC power devices (161, 162), each interfaced with a different converter device port (141, 142). External power devices include DC power loads, DC power sources and rechargeable DC batteries. Rechargeable DC batteries can be used as a DC power source during discharge or as a DC power load or charging load during charging. Generally a DC power load has minimum power amplitude or minimum power load required to operate the power load. In addition the DC power load characteristics may include a peak power load required during some operating states. For DC power loads, the energy management schema is configured to at least allocate the minimum power

and if the instantaneous power available from the DC power bus does not provide at least the required minimum power load the DC power load is not connected to the power bus. Otherwise each power load connected to a device port is connected to the power bus and allocated at least the minimum power load.

[0088] In some instances, a DC power load includes a rechargeable battery installed therein and it is the rechargeable battery that is interfaced to a device port and not the power load. In this case the energy management schema classifies the connected power device as a rechargeable battery and manages power allocation to the rechargeable battery and not to the power load.

[0089] For DC power sources, and rechargeable DC batteries that have a favorable state of charge (SoC) the energy management schema is configured to select the best available power source or rechargeable DC batteries to power the DC power bus and to connect at least one power source to the DC power bus, however two or more power sources can be connected to the power bus at the same time. In a particular configuration, two or more power sources are connected to the power bus at the same time and a current of the power bus is an aggregate of a current of each of the connected power sources. For rechargeable DC batteries that have an unfavorable state of charge, these devices are treated as charging loads and the energy management schema is operable to direct any unallocated power, e.g. not allocated to a DC power load, to one or more rechargeable DC batteries that have an unfavorable state of charge. However in this case there is no minimum power allocation for a charging load.

[0090] More generally, the digital data processor and energy management schema operating thereon are operable to select which external power devices to connect to the DC power bus or to disconnect from the DC power bus e.g. after communicating with the external power device or in response to changes in the power network. Additionally the digital data processor and energy management schema are operable to deliver power to or receive power from any one of the external DC power devices connected to any one of the device ports as warranted by instantaneous characteristics of the power network. As such the power manager and all the connected external DC power devices comprise a power network for exchanging power from one external power device to another while also consuming power to operate the components of the power manager and due to power losses due to power conversions being performed by the DC to DC power

converters. Moreover, the power network can be changed when a user disconnects one external DC power device and replaces it with another. Additionally as charging power is delivered to connected rechargeable DC batteries and or removed from connected rechargeable DC batteries the state of charge of each connected DC battery is changed thereby changing instantaneous power conditions of the entire power network.

[0091] External DC power sources can include any source of DC power, for example: a solar blanket or fuel cell; a vehicle battery or the like; a wind, water, or mechanical driven power generator; an AC power grid source connected to a device port over an external AC to DC power convertor; a DC power source connected to a device port over an external DC to DC power convertor; or the like, as long as the input DC power voltage is either compatible with the instantaneous DC voltage of the DC power bus or can be converted to a bus compatible voltage by one of power converters of the reconfigurable converter power circuits (151, 152).

[0092] Power loads can be connected to the DC power bus (110) to receive power therefrom as long as the power load is either compatible with the instantaneous DC voltage of the DC power bus or can be converted to a bus compatible voltage by one of power converters of the reconfigurable converter power circuits (151, 152). Typical power loads include a DC power device such as most battery operated or DC powered portable devices, such as computers, audio systems including hand held radios, telephones or smart phones, other telecommunications equipment, instruments including navigation systems, weapons, systems, night vision and other photo sensing devices, medical devices, power tools, DC lighting, vehicle power loads, or the like.

[0093] Rechargeable DC batteries can be connected to the DC power bus (110) to receive power therefrom or deliver power thereto as long as rechargeable battery voltage is either compatible with the instantaneous DC voltage of the DC power bus or can be converted to a bus compatible voltage by one of power converters of the reconfigurable converter power circuits (151, 152). A rechargeable DC battery can be discharged to the DC power bus as a power source or charged by the DC power bus (110) when unallocated power is available therefrom.

[0094] As noted above the DC voltage of the DC power bus is matched to the operating voltage of whatever external DC power device is connected to the primary device port (143). Thus according to one aspect of the present invention a user can connect a DC power source to the

primary device port to receive all the source input power without power conversion in order to avoid power converting an input power source and therefore avoiding power conversion losses due to power converting the input power source.

[0095] Exemplary Operating Modes

[0096] The following Examples of operational modes are provided to illustrate certain aspects of the present invention and to aid those of skill in the art in practicing the invention. These Examples are in no way to be considered to limit the scope of the invention in any manner.

[0097] First exemplary operating mode

[0098] In a first exemplary, non-limiting operating mode, at least two external DC power devices (161, 162, 163) are connected to device ports of a power manager (100) but the device ports are not yet connected to the power bus (110) over a corresponding power circuit (151, 152, 153).

[0099] Referring now to Figure 8, in a step (805) the digital processor (120), according to an energy management schema program operating thereon, polls each device port using communication channels (130) to determine if an external power device is connected to the device port.

[00100] In a step (810) the digital data processor determines a device type for each external DC power device connected to a device port.

[00101] In a step (815) the digital data processor determines an operating voltage range and other operating and or power characteristics of each external DC power device connected to a device port.

[00102] In one non-limiting operating mode related to steps (805) through (815), the device type and the other power characteristics of each external DC power device (161, 162, 163) are read from digital data stored on the external DC power device or stored on a smart cable or other digital data processor or data storage device reachable by the digital processor (120).

[00103] In another non-limiting operating mode related to steps (805) through (815), the device type and the other power characteristics are determined at least in part from information obtainable from one or more device port sensors (210, 211, 212) and/or from information stored on the memory module (122). In one example operating mode the device type and other power

characteristics are based on device port sensor information such as signal voltage, current amplitude, and/or power amplitude measurements which can be measured without connecting the device port to the power bus. In addition the energy management schema is operable to compare the device port sensor information with power characteristics of various external DC power device types that are stored in a look-up table, or the like, on the memory module (122). As a result of the comparison of the sensor information and look-up table data the energy management schema can determine a device type and the power characteristics of the external DC power device without reading digital data from the connected external power device.

[00104] In a step (820) the digital data processor (120) uses the energy management schema to select an operating voltage of the DC power bus (110). In all cases where an external power device (163) is connected to the primary device port (143), the operating voltage of the DC power bus (110) is matched to the operating voltage of the primary external DC power device (163). In cases where there is no primary external DC power device (163) connected to the primary device port (143), a power network is still established as long as the power network includes at least two secondary external DC power devices (161, 162) with each DC power device connected to a different secondary converter device port (141) or (142). However if a power network is not established or if a more efficient configuration is available, an error message may be generated by the digital data processor to instruct a user to connect at least one external DC power device to the primary device port.

[00105] In a step (825) the digital data processor (120), using the energy management schema, determines a device priority, if any, for each external DC power device. The device priority may be read from the external power device or may be assigned by the energy management schema according one or more default priority settings and/or instantaneous network conditions.

[00106] In a step (830) the digital data processor (120) determines the instantaneous input power amplitude and the instantaneous output power load demand of the present power network.

[00107] In a step (835) the digital data processor (120) allocates available input power to one or more power loads connected to a device port and allocates any unallocated power to charge one or more rechargeable DC batteries connected to a device port.

[00108] In a step (840) the digital data processor (120) determines how each external DC power device will be connected to the DC power bus, e.g. over the primary power channel, or over one leg of one of the reconfigurable power channels (151, 153).

[00109] In a step (845) the digital data processor (120) determines any voltage conversions that need to be made in order to connect each secondary power device (161, 162) to the DC power bus (110) and sets appropriate voltage conversion settings for each of the DC to DC power converters (220, 221).

[00110] In a step (850) the digital data processor (120) operates one or more of the configurable switches (261) on the primary power channel (153) and or (253, 255, 257, and 259) on the reconfigurable power channels (151, 151) as required to connect appropriate external DC power devices to the power bus over one or more selected circuit legs and or to disconnect appropriate external DC power devices from the power bus as required to allocate power according to the power allocation plan established by the energy management schema.

[00111] In a step (855) the above described steps are repeated at a configurable refresh rate, for example a refresh rate of 20 to 100 msec with the exception that during the initial state prior to repeating step (805) some or all of the device ports are already connected to the DC power bus (110), the type and power characteristics of each external power device and the operating voltage of the DC power bus (110) already may be known and some or all of the switch positions and DC to DC power conversion settings can be maintained if warranted by the present state of the power network.

[00112] In a step (860) the above described steps are repeated whenever there is a change in the network configuration, e.g. when a user physically connects an external DC power device to or disconnects an external DC power device from the power manager (100) or if the power bus sensor module (112) detects a low bus voltage condition that is below a threshold operating DC power bus voltage.

[00113] As noted above, an external DC power load is allocated the full power load demanded thereby unless the full power load allotment is not available. When the full power load allotment is not available, the external DC power load is disconnected from the DC power bus if it

was already connected, or the external DC power load is not connected to the power bus if it had not been previously connected.

[00114] Also as noted above: each external rechargeable DC battery is characterized either as a power source, from which stored energy is drawn to power the DC power bus (110), or as an energy storage device, to which energy is delivered to increase the state of charge of the rechargeable DC battery. However unlike power loads, rechargeable DC batteries can be charged without allocating full charging power, e.g. they can be trickle charged. In other words rechargeable batteries can be charged with whatever level of unallocated power amplitude is available, as long as the available power amplitude does not exceed the batteries' maximum charging rate.

[00115] Thus the energy management schema operates to determine instantaneously available input power amplitude from all external DC power sources and/or rechargeable DC batteries that are connected to a device port and to determine an instantaneous output power demand or load required to meet the full power load of all DC power loads connected to a device port. Thereafter the energy management schema operates to allocate a full power load to as many DC power loads as can be powered by the instantaneously available power. Once all or as many of the power DC loads that can be powered have been allocated full power, all external DC power loads that did not receive a power allocation are disconnected from the power bus (110). Thereafter if there is any unallocated power left over, the unallocated power is distributed to one or more rechargeable batteries, if any, that are connected to device ports. Additionally, when there is insufficient input power available from a power source to power high priority power loads, the energy management schema is operable to discharge one or more rechargeable DC batteries connected to device ports in order to power the high priority power loads. In other words when additional input power is required to power DC power loads, rechargeable DC batteries are used as a DC power source by discharging one or more rechargeable DC batteries to the DC power bus in order to power DC power loads connected to device ports. Additionally, the energy management schema is operable to discharge one or more rechargeable DC batteries connected to device ports in order to charge other rechargeable batteries connected to device ports, e.g. to level the state of charge of all the rechargeable batteries connected to device ports.

[00116] To select a power bus operating voltage, the digital data processor (120) polls the primary device port (143) to gather power characteristics of a connected primary power device (163). The digital data processor then sets an operating voltage of the DC power bus (110) to match the operating voltage of the primary external DC power device (163). In one example embodiment, the digital data processor (120) queries a look up table or the like stored in the associated memory module (122). The look-up table lists a plurality of discreet DC bus voltage operating voltages, including a default bus voltage operating voltage. The digital data processor then selects an operating voltage of the DC bus from the list of discreet operating voltages with the selected discreet operating voltage most closely matched to the operating voltage of the primary external DC power device (163).

[00117] The preselected list of bus voltage operating points is chosen to match the operating voltage ranges of standard primary external DC power devices (163) that are commonly used with the power manager. In one non-limiting example embodiment, the power manager is designed for military use and includes operating voltage ranges typical of hand held or man-portable military devices and portable military batteries. Such man-portable devices may include radios, computers, navigation systems, and instruments each having an operating voltage range centered on any one of 6, 12, 24, 30, and 42 VDC. The operating voltage ranges of the DC to DC power converters (220, 221) are selected to provide voltage conversion over the operating voltage ranges of the standard primary external DC power devices (163) that are commonly used with the power manager which in the present non-limiting example embodiment is a voltage range of between 5 and 50 VDC; however different voltage ranges, including larger ranges, are usable without deviating from the present invention.

[00118] More specifically, in an exemplary embodiment, any external DC power device having an operating voltage range with its mid-point that falls between 5 and 50 volts DC can be connected to the DC power bus over any of the device ports (141, 142, and 143). In a preferred embodiment the power converters (220, 221) are configured for making power conversions over a voltage range of 5 to 50 VDC. Thus with the DC bus voltage set to 5 VDC the power converters are capable of converting the 5 VDC bus voltage to any voltage in the range of 5 to 50 VDC at each secondary device port. Similarly with the DC bus voltage set to 50 VDC, the power

converters are capable of converting the 50 VDC bus voltages to any voltage in the range of 5 to 50 VDC at each secondary device port. In other embodiments, the power manager (100) can be constructed to operate at other bus voltage ranges depending on the application and the availability of appropriate DC to DC power converters.

[00119] Exemplary operating mode for a first network configuration

[00120] Still referring to Figure 8 and steps (805) through (860), during steps (805) – (815) the digital data processor (120) determines that a primary external DC power device (163) interfaced with a primary device port (143) is a DC power source with an operating voltage approximately centered on 24 VDC, that a secondary external DC power device (161) connected to converter device port (141) is a rechargeable DC battery with an operating voltage approximately centered on 12 VDC, and that a secondary external DC power device (162) connected to converter device port (142) is a DC power load having an operating voltage approximately centered around 32 VDC.

[00121] In steps (820) and (825) the energy management schema sets the power bus DC operating voltage at 24 VDC and determines that the DC power source connected to the primary device port (143) has the highest source priority and that the DC power load connected to device port (142) has the highest load priority.

[00122] In steps (830) and (835) the energy management schema determines the instantaneous input power available from the DC power source connected to device port (143) as well as the instantaneous input power available from the rechargeable DC battery connected to the device port (141). The energy management schema determines the instantaneous power load being demanded by the DC power load connected to the device port (142) and based on the State of Charge (SoC) and energy storage capacity of the rechargeable DC battery connected to the device port (141) determines an instantaneous power load associated with the rechargeable DC battery. Thereafter the instantaneous input power is allocated first to the DC power load connected to device port (142) because the DC power loads has the highest load priority, and second to recharge the rechargeable DC battery connected to device port (141). If the instantaneous input power amplitude meets or exceeds the instantaneous power load being demanded by the DC power load, the full instantaneous power load being demanded by the DC power load is allocated. If not, no

power is allocated to by the DC power load connected to the device port (142). If the instantaneous input power amplitude exceeds the instantaneous power load being demanded by the DC power load, the excess unallocated power is allocated to recharge the rechargeable DC battery connected to the device port (141). If the instantaneous input power amplitude is less than the instantaneous power load being demanded by the DC power load, no power is allocated to the DC power load and the instantaneous input power amplitude is fully allocated to recharge the rechargeable DC battery connected to the device port (141). In cases where neither solution is workable, e.g. when the instantaneous input power amplitude exceeds the power demand on the network or may damage the network, the instantaneous input power is rejected and a new solution is attempted, e.g. to use the rechargeable DC battery connected to the device port (141) to power the DC power load connected to the device port (142).

[00123] In steps (840) – (850) the energy management schema determines a connection scheme for connecting each device to the DC power bus (110) according to the power allocation scheme. Along the primary power channel (153) the switch (261) is closed to connect the primary device port (143) and the connected DC power source to the power bus. This step powers the DC power bus at 24 VDC as provided by the 24 VDC power source connected to the primary device port (143).

[00124] The reconfigurable power channel (152) is configured as shown in Figure 5 by opening switches (257) and (255) and closing switches (253) and (259). The DC to DC power converter (220) is set to receive an input power signal from the DC power bus at 24 VDC and to step the input power signal up to 32 VDC in order to power the 32 VDC power load connected to the device port (142).

[00125] The reconfigurable power channel (151) is also configured as shown in Figure 5 by opening switches (257) and (255) and closing switches (253) and (259). The DC to DC power converter (221) is set to receive an input power signal from the DC power bus at 24 VDC and to step the input power signal down to 12 VDC in order to recharge the 12 VDC rechargeable battery connected to the device port (141).

[00126] If at any time, the 12 VDC rechargeable DC battery connected to the device port (141) is used as a power source to allocate input power to the power bus, the reconfigurable power

channel (152) is reconfigured as shown in Figure 6 by opening switches (253) and (259) and closing switches (255) and (257). The DC to DC power converter (221) is set to receive an input power signal from the rechargeable DC battery connected to the device port (141) at 12 VDC and to step the input power signal up to 24 VDC in order to deliver input power to the power bus (110).

[00127] In a further exemplary operating example, each of the DC to DC power converters is operable to modulate current amplitude of a power signal passing through the DC to DC power converter. In particular the current amplitude of a power signal entering the power converter input terminal (222) may be passed through the DC to DC power converter substantially unmodulated, i.e. at full current amplitude, of substantially fully modulated, i.e. substantially zero current amplitude.

[00128] Exemplary operating mode for a second network configuration

[00129] Still referring to Figure 8 and steps (805) through (860), during steps (805) – (815) the digital data processor (120) determines that a primary external DC power device (163) interfaced with a primary device port (143) is a DC power source with an operating voltage approximately centered on 24VDC, that a secondary external DC power device (161) connected to converter device port (141) is a rechargeable DC battery with an operating voltage approximately centered on 24 VDC, and that a secondary external DC power device (162) connected to converter device port (142) is a rechargeable DC battery with an operating voltage approximately centered on 24 VDC.

[00130] In steps (820) and (825) the energy management schema sets the power bus DC operating voltage at 24 VDC and determines that the DC power source connected to the primary device port (143) has the highest source priority and that each of rechargeable DC batteries connected to device ports (141, 142) have an equal load priority.

[00131] In steps (830) and (835) the energy management schema determines the instantaneous input power available from the DC power source connected to device port (143) as well as the instantaneous input power available from each of the rechargeable DC batteries connected to the device ports (141, 142). The energy management schema determines the instantaneous power load being demanded by each of the rechargeable DC batteries connected to the device ports (141, 142), e.g. based on the State of Charge (SoC) and energy storage capacity of

each rechargeable DC battery connected to the device port (141, 142). Thereafter the instantaneous input power may be equally divided between the two rechargeable DC batteries, may be fully allocated to one or the other of the two rechargeable DC batteries, or may be partially allocated to each of the two rechargeable DC batteries in unequal portions.

[00132] In steps (840) – (850) the energy management schema determines a connection scheme for connecting each device to the DC power bus (110) according to the power allocation scheme. Along the primary power channel (153) the switch (261) is closed to connect the primary device port (143) and the connected DC power source to the power bus. This step powers the DC power bus at 24 VDC as provided by the 24 VDC power source connected to the primary device port (143).

[00133] The reconfigurable power channels (151, 152) are both configured as shown in Figure 7 by opening switches (257) and (259) and closing switches (253) and (255). The DC to DC power converter (220) of each circuit (151, 152) is not in use so may be powered down.

[00134] In an alternate connection scheme, the reconfigurable power channels (151, 152) are both configured as shown in Figure 5 by opening switches (255) and (257) and closing switches (253) and (259). In this case the DC to DC power converter (220) is set for no voltage change and is still usable to attenuate current without a DC to DC voltage conversion. If at any time, one or both of the 24 VDC rechargeable DC batteries connected to the device port (141, 142) is used as a power source to allocate input power to the power bus, the reconfigurable power channels (151, 152) do not require reconfiguration as long as the DC power bus operating voltage is 24 VDC.

[00135] Exemplary operating mode for a third network configuration

[00136] Still referring to Figure 8 and steps (805) through (860), during steps (805) – (815) the digital data processor (120) determines that a primary external DC power device (163) interfaced with a primary device port (143) is a DC power load with an operating voltage approximately centered on 12 VDC, that a secondary external DC power device (161) connected to converter device port (141) is a rechargeable DC battery with an operating voltage approximately centered on 24 VDC, and that a secondary external DC power device (162) connected to converter device port (142) is a rechargeable DC battery with an operating voltage approximately centered on 32 VDC.

[00137] In steps (820) and (825) the energy management schema sets the power bus DC operating voltage at 12 VDC and determines that the DC power load connected to the primary device port (143) has the highest load priority and that each of the rechargeable DC batteries connected to device ports (141, 142) have an equal load and an equal source priority.

[00138] In steps (830) and (835) the energy management schema determines the instantaneous input power available from each of the rechargeable DC batteries connected to device ports (141) and (142). The energy management schema determines the instantaneous power load being demanded by each of the rechargeable DC batteries connected to the device ports (141, 142), e.g. based on the State of Charge (SoC) and energy storage capacity of each rechargeable DC battery connected to the device port (141, 142). Thereafter the instantaneous input power available from one or both of the rechargeable DC batteries connected to the device ports (141, 142) is allocated to the power the DC power load connected to the primary device port (143).

[00139] In steps (840) – (850) the energy management schema determines a connection scheme for connecting each external power device to the DC power bus (110) according to the power allocation scheme. Along the primary power channel (153) the switch (261) is closed to connect the primary device port (143) and the connected DC power load to the power bus. The reconfigurable power channels (151, 152) are both configured as shown in Figure 6 by opening switches (253) and (259) and closing switches (255) and (257). The DC to DC power converter (221) associated with reconfigurable power circuit (151) is set to receive an input power signal at 24 VDC from the rechargeable DC battery connected to the device port (141) and to step the input power signal down to 12 VDC in order to deliver input power to the power bus (110). The DC to DC power converter (220) associated with reconfigurable power circuit (152) is set to receive an input power signal at 32 VDC from the rechargeable DC battery connected to the device port (142) and to step the input power signal down to 12 VDC in order to deliver input power to the power bus (110).

[00140] In order to meet the power demand of the DC power load connected to the primary device port (143) either one of the rechargeable DC batteries connected to secondary device ports (141) and (142) can be used exclusively by connecting one or the other to the DC power bus. Alternately, in order to meet the power demand of the DC power load connected to the primary

device port (143) both of the rechargeable DC batteries connected to secondary device ports (141) and (142) can be connected to the DC power bus at the same time. In cases where the instantaneous input power available from one the rechargeable DC batteries connected to the device ports (141) and (142) exceeds the DC power load demanded by the DC power source connected to device port (143) any unallocated power is directed to the other rechargeable DC batteries by reconfiguring the associated reconfigurable circuit to receive DC power from the power bus, e.g. as is shown in Figure 5. However this action is controlled by the energy management schema by configuring reconfigurable power channels to distribute unallocated instantaneous input power to selected rechargeable DC batteries based on the state of charge and charge capacity of the connected rechargeable DC batteries. According to a further exemplary operating mode one or both of the DC to DC power converters is set to modulate current amplitude as a means of modulating instantaneous input power being delivered to the DC power bus (110). According to a further exemplary operating mode DC power is only drawn from the rechargeable DC battery having the highest instantaneous input power available. According to another exemplary operating mode DC power is only drawn from the rechargeable DC battery having the lowest instantaneous input power available.

[00141] Maximum power point tracking exemplary operational mode

[00142] In a further non-limiting exemplary network configuration and operating mode, a DC power load or rechargeable DC battery having a low state of charge is connected to the primary device port (143). A first high priority power source such as a renewable energy source, e.g., a solar blanket or wind turbine, or the like, that tends to have a continuously fluctuating voltage and therefore continuously variable power amplitude is connected to secondary converter device port (141). A second high-priority power source such as a renewable energy source, e.g., a solar blanket or wind turbine, or the like, that tends to have a continuously fluctuating voltage and therefore continuously variable power amplitude is connected to a secondary converter device port (142).

[00143] In one operating mode the energy management schema sets the DC bus voltage to match the operating voltage of the DC power load or of the low state of charge rechargeable DC

battery and connects all of the external power device to the DC power bus using appropriate power conversion settings as described above.

[00144] In a further exemplary operating mode, the digital data processor (120) is operable to run Maximum Power Point Tracking (MPPT) algorithms to modulate input power from one or both of the high priority DC power sources connected to the converter device ports (141, 142). The MPPT algorithms are usable to convert input power from the variable voltage secondary power sources (e.g. having time varying input power amplitude) to usable power having substantially constant voltage that is compatible with the operating voltage of the DC power bus (110). The operating voltage range of the input power source can be determined either by communicating with the input power source or may be inferred from sensor signal feedback. Once the input voltage range is determined the digital data processor (120) configures the reconfigurable converter power circuit (151, 152) corresponding to the converter device port (141, 142) as a power converting input power channel (232), as shown in Figure 6, and provides set points to the DC to DC power converter (220, 221) to match the incoming voltage to the bus compatible operating voltage. Additionally, each DC to DC power converter (220, 221) is operable to modulate input current amplitude between substantially zero throughput and full throughput. Thus, the digital data processor (120) is operable to monitor input power amplitude at the power sensor (210, 211) and to modulate power output amplitude exiting the DC to DC power converters by varying current amplitude at the DC to DC power converter (220, 221).

[00145] Standalone reconfigurable power circuit

[00146] Referring to Figures 9a and 9b, an exemplary, non-limiting reconfigurable power circuit (400, 401) according to the present invention is shown in schematic view. Reconfigurable power circuit (400, 401) is similar to first and second reconfigurable converter power circuits (151, 152), shown in Figure 4, and like components are numbered with like numbers. The reconfigurable power circuit (400, 401) includes a one-way DC to DC power converter (220), a plurality of converter channel legs (243, 245, 247, and 249) a plurality of configurable switches (253, 255, 257, and 259), a first electrical connection interface (271) and a second electrical connection interface (272). As will be further detailed below, either or both of the first and second electrical connecting interfaces described herein may be implemented as a device port or interfaced

with a device port or a DC power bus. A device port is a wired connector interface; however, a wireless power interface such as by induction is usable without deviating from the present invention.

[00147] An external DC power device is connected to a device port with a wire interface that includes a terminal connector that can be plugged into the device port. Typically, a device port connection is temporary and can be changed by a user such as by connecting one external DC power device to the device port, e.g. to be charged, or otherwise powered, and then removing by the user and possibly be replaced by another external DC power device. A non-limiting exemplary device port embodiment is shown in Figures 2 and 3 and another is shown schematically in Figure 11. In a non-limiting embodiment shown in Figure 10 the second electrical connection interfaces (272a, 272b) each connect with a common DC power bus (110) such as by hard-wiring, or the like. In other non-limiting embodiments either one of the first or the second electrical connection interfaces (271, 272) is hardwired to a DC power device, e.g. a DC power source or rechargeable DC battery or a DC power load.

[00148] The one-way DC to DC power converter (220) includes an input terminal (222) and an output terminal (224). Current flow through the one-way DC to DC power converter (220) is directed to the input terminal by the reconfigurable power circuit and exits from the output terminal. DC to DC power conversions, when required, can be carried out by establishing an appropriate configuration of the reconfigurable power circuit (400, 401) to direct current flow to the input terminal (222, 222a, 222b). As described above and shown in Figures 5-7, the reconfigurable circuit can be configured as a first power converting circuit (230), shown in Figure 5, as a second power converting circuit (232), shown in Figure 6, or as a non-power converting circuit (234), shown in Figures 7 and 10.

[00149] Figure 10 depicts an alternate configuration of a non-power converting circuit (400a) which is an alternate configuration of the non-power converting circuit (234) shown in Figure 7. As shown in Figure 7 the non-power converting circuit (234) is configured with the configurable switches (257, 259) both open to prevent current flow over the corresponding circuit legs (247) and (249) and with the configurable switches (253, 255) both closed to allow current flow over the corresponding circuit legs (243) and (245).

[00150] As shown in Figure 10, the non-power converting circuit (400a) is configured with the with only one configurable switch (225a) open to prevent current flow over the circuit leg (245a) and thereby forcing current flow to the input terminal (222a). Otherwise the non-power converting circuit (400a) is configured with three of the configurable switches (253a, 257a, 259a) all closed to allow current flow over the circuit leg (243a) to the input terminal (222a), to the output terminal (224a) to the circuit leg (249a) and to the device port (141). In the non-power converting circuit (400a), the DC to DC power converter (220) is set with a zero-voltage conversion set point which allows current to flow through the DC to DC power converter (220) without a voltage conversion. In addition to providing a zero-voltage conversion set point to the DC to DC power converter, the energy management schema is operable to attenuate current amplitude by providing a stream of instantaneous current attenuation set points to the DC to DC power converter (220) which cause the DC to DC power converter to vary current amplitude between substantially zero current amplitude and maximum current amplitude available.

[00151] The non-power converting circuit (400a) of Figure 10 provides three advantages over the non-power converting circuit (234) shown in Figure 7. The first advantage is provided by the ability to attenuate current amplitude which allows the energy management schema to attenuate power amplitude without voltage variation. Additionally, the output current amplitude is measured by the output current sensor (265a) and an output current amplitude signal generated by the output current sensor is usable by the energy management schema to track output current and power amplitude. A second advantage over the non-power converting circuit (234) shown in Figure 7 is the ability to operate the MPPT module (512), shown in Figure 11, without voltage conversion. In a non-limiting exemplary operating mode, the non-power converting circuit (400a) is usable with MPPT control in situations where the input power voltage is time varying over a small range and current attenuation control is used to maintain a substantially constant output power amplitude with less voltage variation than the input voltage variability. A third advantage over the non-power converting circuit (234) shown in Figure 7 is the ability to charge both an input bulk capacitor (222a) and an output bulk capacitor (224a) which are each described in detail below. In particular, as will be described below, charging the bulk capacitors (222a, 224a) delays voltage drops that occurring while the configuration of the reconfigurable power circuit is being changed or due to

sudden voltage drops e.g. when an external DC power load is connected to the DC power bus over one of the reconfigurable circuits (400a, 400b), or the like.

[00152] According to an aspect of the present invention, one-way DC to DC power converter (220) includes input bulk capacitor (225) disposed along the first converter channel leg (245) between the input terminal (222) and each of the first configurable switch (253) and the second configurable switch (255). Alternately, input bulk capacitor (225) can be positioned inside the DC to DC power converter (220). An output bulk capacitor (227) is also disposed along the third converter channel leg (247) between the output terminal (224) and each of the third configurable switch (257) and the fourth configurable switch (259). Alternately, output bulk capacitor (225) can be positioned inside the DC to DC power converter (220). Otherwise, any bulk capacitance device or circuit that includes a bulk capacitance device that is interfaced with any one of the input terminal (222), the output terminal (224) or is incorporated inside the one-way DC to DC power converter (220), or associated with one of the configurable switches (255a, 257a, 255b, 257b) is usable without deviating from the present invention. The bulk capacitance devices are provided to prevent a sudden short-term voltage drops from disrupting power distribution.

[00153] Such short-term voltage drops may occur when the reconfigurable power circuit is being reconfigured, e.g. while switching from a primary power source to a secondary power source, when an external DC power device is unplugged from a device port, when an energy power source becomes depleted, or when the charge capacity of a rechargeable DC battery falls below a threshold value. Preferably, the capacitance of each bulk capacitor is chosen to prevent a sudden voltage drop for a short time duration. In an example, it is desirable to limit a sudden voltage drop to less than 50% of the operating voltage amplitude for a period of 10 to 100 msec. The bulk capacitors therefore delay a low power situation for long enough to prevent external power loads from failing in some manner. Mainly, the bulk capacitors are provided to prevent more than 50% voltage amplitude drops for at least long enough for the reconfigurable power circuit to reconfigure itself to bring a secondary power source on line to replace the primary power source.

[00154] In example embodiments the capacitance of the bulk capacitors is selected to correspond with providing less than a 50% voltage drop for 10-20 msec after an abrupt but temporary power loss such as may occur while switching any of the configurable switches to

change the configuration of the reconfigurable circuit. In other embodiments, the capacitance of the bulk capacitors is selected to correspond with providing less than a 50% voltage drop for up to 100 msec. Other advantages of including the bulk capacitors relate to limiting power amplitude peak to valley spreads at device ports and at other electrical connection interface points associated with external power devices and or internal power devices e.g. the digital data processor, various power sensors, or the like. Additionally, the capacitance of the input and output bulk capacitors is selected to diminish voltage amplitude ripple and noise in the reconfigurable power circuit (400, 401). The reconfigurable power circuit (400, 401) includes an input current sensor module (262) disposed along converter channel leg (245) between configurable switch (255) and power converter input terminal (222). The reconfigurable power circuit (400) also includes an output current sensor module (265) disposed along, converter channel leg (249) between configurable switches (257) and (259) and power converter output terminal (224). Alternately, in the reconfigurable power circuit (401), the output current sensor module (265) is disposed along converter channel leg (247) between configurable switch (257) and power converter output terminal (224). Figures 9a and 9b depict the position of the input current sensor module (262) and the output current sensor (265) for two different embodiments of a reconfigurable power circuit (400, 401).

[00155] Each of the input current sensor module and the output current sensor module is in communication with a digital data processor (120) shown in Figure 10. The input current sensor module measures and reports an instantaneous DC current amplitude along converter channel leg (245) when the reconfigurable power circuit is configured as the one-way input power converting circuit (232) shown in Figure 6, for converting a voltage amplitude of power input received from the first electrical connection interface (271) when configurable switches (255 and 257) are both closed and configurable switches (253 and 259) are both open. The input current sensor module also measures and reports an instantaneous DC current amplitude along channel leg (243, 245) when the reconfigurable power circuit is configured as the bidirectional non-power converting channel (234), shown in Figure 7, for a direct exchange of power between the first interface (271) and the second interface (272) when configurable switches (257 and 259) are both open and configurable switches (253 and 255) are both closed.

[00156] The output current sensor module measures and reports an instantaneous DC current amplitude along converter channel leg (247) and/or (249), depending on location, when the reconfigurable power circuit is configured as a one-way output power converting channel (230), shown in Figure 5, with configurable switches (253 and 259) both closed and configurable switches (255 and 257) both open. The output current sensor module also measures and reports an instantaneous DC current amplitude along converter channel leg (247) when the reconfigurable power circuit is configured as the one-way power channel (232), shown in Figure 6, when controllable switches (253) and (257) are both open and controllable switches (255) and (259) are both closed.

[00157] The reconfigurable power circuit (400, 401) optionally includes input voltage sensor module (264) and output voltage sensor module (267). The input voltage sensor module is disposed along the converter channel leg (245) between each of the controllable switches (253) and (255) and input terminal (222) and measures and reports instantaneous DC voltage proximate to power converter input terminal (222). The output voltage sensor module is disposed along power converter channel (247) between output terminal (224) and each of the switches (257) and (259) and measures and reports instantaneous DC voltage proximate to the power converter output terminal (224). Although a single input current sensor (262) and a single output current sensor (265) are illustrated in Figures 9a and 9b, additional exemplary embodiments of reconfigurable power circuit (400, 401) can include one or more additional current or voltage sensors. Also input and output current and voltage sensor modules can be implemented as a single power sensor module that measures and reports power amplitude.

[00158] In an example, each current sensor (262, 265), voltage sensor (264, 267), power sensor, generates a power, current or voltage amplitude signal that is received by a digital data processor (120). When the digital data processor senses a power amplitude drop that is below a low power amplitude threshold, a mitigation action is triggered. The mitigation action may include the digital data processor reconfiguring the reconfigurable power circuit to select a different input power source or to disconnect a power load, or the like.

[00159] **Power manager**

[00160] Referring to Figure 10, an exemplary, non-limiting embodiment of a DC power manager (1000) according to the present invention is shown in schematic view. The exemplary embodiment of power manager (1000) includes first reconfigurable power circuit (400a) and second reconfigurable power circuit (400b) each interfaced with a DC power bus (110). The power manager (1000) also includes a primary power channel (153) also interfaced with the DC power bus (110). The DC power manager (1000) optionally includes a bus power sensor (112) that monitors a DC voltage amplitude, a DC current amplitude or a DC power amplitude at the DC bus (110). The DC power manager (1000) further includes a digital data processor (120) and associated memory module (122).

[00161] A first device port (141) provides a first electrical connection interface (271a) to the first reconfigurable power circuit (400a). A second device port (142) provides a second electrical connection interface (271b) of second reconfigurable power circuit (400b). A second electrical connection interface (272a) of first reconfigurable power circuit (200a) and a second electrical connection interface (272b) of second reconfigurable power circuit (200b) are each electrically coupled to the DC power bus (110).

[00162] The digital data processor (120) is in communication with control elements of each of the first and second reconfigurable power circuits (400a, 400b) including current sensor modules (262a, 262b, 265a, and 265b), voltage sensor modules (264a, 264b, 267a, and 267b), one way DC to DC power converters (220, 221) and configurable switches (253a, 253b, 255a, 255b, 257a, 257b, 259a, and 259b).

[00163] Digital data processor (120) is operable to receive communication signals including measurement values from current sensor modules (262a, 262b, 265a, and 265b) and from voltage sensor modules (264a, 264b, 267a, and 267b) and to communicate command signals, e.g. instantaneous voltage conversion set points to each of the one way DC to DC power converters (220, 221) and configuration settings to each of configurable switches (253a, 253b, 255a, 255b, 257a, 257b, 259a, and 259b). The digital data processor (120) is further operable to independently configure each of the first and second reconfigurable power circuits (400a, 400b) as any one of the three different reconfigurable power circuits (230), shown in Figure 5; (232), shown in Fig, 6; and (234), shown in Figure 7, each of which is each described above.

[00164] As described above related to Figures 9a and 9b, each input current sensor modules (262a, 262b) measures instantaneous DC current amplitude on converter channel leg (245a, 245b) and reports DC input current amplitude measurement values to controller (120). Likewise, each output current sensor module (265a, 265b) measures instantaneous DC current amplitude on converter channel legs (247a, 247b, 249a, 249b), depending on location, and reports DC output current amplitude measurement values to controller (120). Each input voltage sensor module (264a, 264b) measures instantaneous DC voltage amplitude at input terminal (222) and each output voltage sensor module (267a, 267b) measures instantaneous DC voltage amplitude at output terminal (224) and reports DC input current amplitude measurement values to controller (120).

[00165] In a preferred embodiment, the voltage of power bus (110) is configured by the energy management schema to match an operating voltage of a primary power device (163) that is electrically interfaced with primary device port (143). Preferably the primary power source, such as the most reliable power source, is interfaced with the primary device port (143) in order to match the DC bus voltage with the voltage of the primary power source. This configuration is preferred because it is desirable to avoid a voltage conversion of the input power source because this can lead to larger than necessary power conversion losses. As such, a user will be advised to use the primary device port (143) as an input power port corresponding with the most reliable power source, e.g. a DC power supply or fully charged DC energy storage device. However, the primary device port (143) can be interfaced with any external DC power device type without deviating from the present invention.

[00166] Referring now to Figures 8 and 10, an operating process is described for the power manager (1000). In a step (805) the energy management schema polls each device port to determine if an external DC power device is connected to the device port. In step (810) the energy management schema determines a device type, e.g. whether the connected device is a power load, a power source, a rechargeable battery or other energy source. In step (815) the energy management schema determines the power characteristics of each external DC power device. For a power load, its operating voltage range in volts and its average and peak power load requirements in watts is determined. For a rechargeable battery, its state of charge, e.g. percentage full or empty, and its charge capacity, e.g. in ampere hours, is determined. For a power source, its average and peak

input power capacity, in watts is determined. In step (820) the step of selecting the operating voltage for the system (1000) has a default selection which is to set the DC bus voltage to match the operating voltage of the primary device (163) connected to the primary device port (143). In Step (825) the energy management schema determines device priorities which may be included in step (815) by reading device priorities from each connected external DC power devices. Otherwise, device priorities may be dictated by the energy management schema according to one or more predetermined device priority rules or policies and or situation-based rule configuration settings. In step (830) the energy management schema determines an available input power amplitude, e.g. from more than one input power source, and an output power demand, e.g. by more than one DC power loads, according to the device power characteristics collected in step (815), and allocates the input power to one or both of the connected external DC power devices (161, 162) in step (835). The allocation step (835) preferably allocates full power demand to connected DC power loads and allocates any unallocated power to rechargeable DC batteries. In a situation wherein the input power amplitude is insufficient to meet the full power demand of one or more of the connected DC power loads, the energy management schema will, under some circumstances, use the rechargeable DC battery as a power source to supplement available power or will simply not deliver power to one or more power loads. In step (840) the energy management schema determines how power devices will be connected to the power bus (110). In various configurations step (840) includes connecting one two or all three power devices ports to the power bus (110). In step (845) the energy management schema determines voltage conversion settings corresponding with each one-way DC to DC power converter (220, 221), and in some instances, current attenuation settings for each one-way DC to DC power converter (220, 221). In step (850) the energy management schema establishes the configuration of each of the reconfigurable power circuits (400a, 400b) by operating appropriated configurable switches and selecting voltage set points as required to provide voltage conversions at either of the one-way DC to DC power converters (220, 221). As soon as the voltage set points are enforced and the configurable switches are configured, power is routed through the power manager according to the configuration selected by the energy management schema. As shown in Steps (855) and (860) the process (800) is either

periodically repeated or repeated in response to a change in the power network configuration or status.

[00167] The reconfigurable power circuits (400a, 400b) provide an advantage over conventional reconfigurable power circuits because the input current sensor (262a, 262b) and/or the input voltage sensors (264a, 264b) sense actual instantaneous input power conditions and feed this information to the energy management schema. Similarly, the output current sensor (265a, 265b) and/or the output voltage sensors (267a, 267b) sense actual instantaneous input power conditions and actual instantaneous output power conditions and feed this information back to the energy management schema.

[00168] The energy management schema is thus further configured to monitor instantaneous input power conditions and instantaneous output power conditions and to implement finer grained control over power conditions than was previously achievable. In particular, the energy management schema is operable to maintain a substantially constant output voltage amplitude at each of the output terminals (224a, 224b) by altering the voltage conversion setting at corresponding one-way DC to DC power converters (220, 221). In addition, or alternately, the energy management schema is operable to maintain a substantially constant output current amplitude at each of the output terminals (224a, 224b) by altering a current attenuation setting at corresponding one-way DC to DC power converters (220, 221). In addition, or alternately, the energy management schema is operable to maintain a substantially constant output power amplitude at each of the output terminals (224a, 224b) by altering one or both of the voltage conversion setting and the current attenuation settings at corresponding one-way DC to DC power converters (220, 221).

[00169] **Power Node**

[00170] Referring to Figure 11, an exemplary, non-limiting power node (500) according to the present invention is shown in schematic view. The exemplary power node (500) includes reconfigurable power circuit (400) disposed within a power node housing (570) between a first power device port (530) and a second power device port (532). First electrical connection interface (271) is electrically coupled to the first power device port and second electrical connection interface (272) is electrically coupled to the second power device port. Each power device port

(530, 532) is electrically connectable to an external power device (540, 542) by a wired interface, such as by a connector end-point shown in Figures 2 and 3. Each external power device (540, 542) is an external DC power device that can be connected to either the first power device port (530) or the second power device port (532). In further embodiments, one or both of the external power device ports (530, 532) are electrically connectable to a power bus architecture.

[00171] The power node (500) includes an electronic controller (510) that includes a power node digital data processor and associated power node power node memory module, therein. The power node digital data processor includes a programmable logic device operating an energy management schema program thereon and carrying out logical operations such as communicating with external DC power devices (540, 542), managing the memory module to store and recall data, reading sensor signals from voltage, current, and power sensors, and operating configurable switches and the DC to DC power converters to configure the reconfigurable power circuit according to one of the three power circuits (230, 232, 234) shown in Figures 5-7 of the power node.

[00172] Referring now to Figure 11 the power node (500) includes a power node communication network (560). The power node communication network (560) is substantially similar to the previously discussed communication channel (130) of power manager (100). The power node communication network (560) includes one or more network or similar communication interface devices (514) interconnecting various internal devices and modules to the electronic controller (510) and specifically to the power node digital data processor for digital communication and or analog signal exchange. The communication network (560) optionally includes additional network communication interface devices (514) operable to communicate with other power nodes and or with remote power managers, or otherwise to gain access to various devices and services over intermediate networks, such as a wired local area network (LAN), a wireless local area network (WLAN), a peer-to-peer network, a Wireless Wide Area Network (WWAN), such as a cellular or medium range radio network, or the like. Preferable, intermediate networks provide access to a Wide Area Network (WAN) so that individual power nodes (500) can reach WAN based network devices such a policy server, an authentication or authorization server, an Identity Provider, (IdP), a Domain Name Server (DNS), or the like.

[00173] Each wireless network interface device (514) is configured to receive communication signals configured in a first communication protocol structure and to translate the first communication protocol signals to a second communication protocol structure as needed to facilitate communication between devices configured to use different communication protocols. The communication channels also may extend between internal modules of the power node (500) without interface with the power node digital data processor and may include analog channels for exchanging analog signals including sensor signals generated by various current voltage or power sensors. Each device port (530, 532) is connected with the power node electronic controller (510) e.g. with the digital data processor over at least one communication network channel. Accordingly, when an external power device is connected with any one of the device ports, the external DC power device joins the communication network established by the communication interface device (114) for communication with the power node digital data processor.

[00174] Additionally, the power node communication network (560) may include conductive paths, wires or the like, for exchanging analog or digital signals between electronic components of the reconfigurable power circuit such as various switches, sensors, and power converters and the electronic controller (510). In particular, the power node communication network (560) extends from the power node digital data processor to each controllable element of the power node (500) including configurable switches (253, 255, 257, 259), current sensor modules (262, 265), voltage sensor modules (264, 267), other power sensors (550, 552) and power converters (220) to deliver control signals thereto and to receive sensor signals, or the like, therefrom. The control signals include configuration and setting instructions for operating each controllable element to reconfigure the spinning convert circuit and establish voltage conversion and current attenuation settings at the one-way DC to DC power converter (220) as dictated by the energy management schema. The communication channels may further include a one-wire identification interface extending between the power node data processor (560) and each device port configured to enable the power node digital data processor (560) to query a connected external power device (540, 542) for power characteristics information.

[00175] Power node digital data processor is configured to communicate control signals to the one-way DC to DC power converter (220) and to the configurable switches (253, 255, 257, and

259). The power node digital data processor is configured to receive measurement signals such as a stream of instantaneous current amplitude signals from current sensor modules (262 and 269) and a stream of instantaneous voltage amplitude signals from voltage sensor modules (264 and 267). In an exemplary embodiment, power node (500) includes optional first device port power sensor module (550) operable to measure power characteristics of a power signal at first power device port (530) and an optional second device port power sensor module (552), operable to measure power characteristics of a power signal at second device port (532). The first and second device port power sensor modules are operable to report power characteristics measurement values, e.g., values of current and/or voltage, to the power node digital data processor.

[00176] The power node can include an optional internal battery (520). The internal battery is a rechargeable battery that can be charged when the power node is operably connected to a power source, to an external rechargeable battery, or to an external power bus architecture capable of providing charging power to the internal battery (520). The internal battery provides power to the power node digital data processor, for example when a power source or rechargeable battery is not connected to either of first device port (530) and second device port (532) or when external DC power devices connected to the device ports are incapable of providing power or when the power node is connected to a power bus architecture that does not provide charging power to the power node.

[00177] As illustrated in Figure 11, first external power device (540) is electrically coupled to first device port (530) and a second external power device (542) is electrically coupled to second power device port (532). The power node digital data processor determines device type and power characteristics of each electrically coupled external power device, for example by establishing a communication session with each external power device to determine the characteristics. The power node digital data processor can also determine power characteristics of one or both power devices based on power measurement signals communicated to the power node digital data processor by the first power sensor module (550) and the second power sensor module (552). After determining external power device type and power characteristics, the power node digital data processor controls the one way DC to DC power converter and configurable switches of the reconfigurable power circuit (400) to configure the reconfigurable power circuit (400) to exchange

power between the power devices connected to the external device ports. In an exemplary configuration, first power device (540) is a power source operating at a first DC voltage and second power device (542) is a power load operating at a second DC voltage that is different from the first DC voltage. The power node digital data processor configures the reconfigurable power circuit (400) as one of the three reconfigurable power configurations (230, 232, 234) shown in Figures 5-7. In a first exemplary configuration, the reconfigurable power configuration (232), shown in Figure 6, is established by the power node data processor by operating the configurable switches and setting voltage conversion and optionally current attenuation settings for the power converting input power channel to receive input power from the first external DC power device (540) at a first voltage and to deliver output power to the second external DC power device (542) at a second voltage. In a second exemplary configuration wherein the first power device (540) is a power load operating at a first voltage and the second power device (542) is a power source operating at a second voltage, different from the first voltage, the power node digital data processor configures the reconfigurable power circuit as the power converting output power channel (230) shown in Figure 5 to receive input power from the second external DC power device (542) at the second voltage and to deliver output power to the first external DC power device (540) at the first voltage.

[00178] In a third exemplary configuration wherein each of the first external DC power device (540) and the second external DC power device (542) the same voltage and the power node digital data processor configures the reconfigurable power circuit as the bidirectional non-power converting circuit (234), shown in Figure 7. In this operating mode, one or both of the external DC power devices can be a rechargeable DC battery that is used as a source e.g. by discharging to power a DC power load, or as a DC power load e.g. by charging the DC battery from a DC power source.

[00179] In a further exemplary embodiment, the first power device (540) includes a variable voltage power source such as, for example, a solar blanket, a wind turbine, or other fluid driven device, e.g. a water wheel and the second power device (542) includes a rechargeable DC battery or a DC power load. In this exemplary configuration, the power node digital data processor configures the reconfigurable power circuit as the one-way input power converting circuit (232) shown in Figure 6 and operates the Maximum Power Point Tracking (MPPT) module (512), shown

in Fig. 11, to implement a maximum power point tracking method while converting input power received from the variable voltage power source (540) (e.g. having time varying input power amplitude) to usable power having substantially constant output voltage that is compatible with the operating voltage of the second power device (542). The instantaneous operating voltage or power amplitude of the variable voltage input power source (540) is provided to the electronic controller (510) as a stream of voltage amplitude signals generated by the input power sensor (550). Similarly, the instantaneous voltage at the output terminal (224) is provided to the electronic controller (510) as a stream of voltage amplitude signals generated by the output power sensor (550).

[00180] The controller (515) implements a perturb and observe (P&O) PPT process for tracking an input power amplitude as a function of an output current set point of one of the one-way DC to DC power converter (220). To find an output current set point that results in peak input power the (P&O) PPT process monitors the input power sensor (550) while incrementally varying the output current amplitude of at the DC to DC power converter (220). Thus the DC to DC power converter (220) is operated to incrementally modulate current amplitude through a range of current amplitude values while monitoring input power at the input power sensor (530). After tracking power through the selected current range a peak power operating point is selected and the selected DC to DC power converter is set to a current amplitude operating point corresponding with the peak input power level. If the input power source delivers substantially non-varying or narrowly varying input power amplitude, the DC to DC power converter may be set to the same current set point associated with maximizing input current amplitude. If the input power amplitude is temporally variable the (P&O) PPT process may be repeated, e.g. at a refresh rate. In either case the DC to DC power converter current amplitude operating point may be refreshed at the refresh rate, such as every 20 to 100 msec.

[00181] The power device ports (530, 532) of power node (500) are connectable to a power bus architecture. The DC bus architecture is operated at a DC bus voltage or voltage range which is preselected. In a further embodiment either the first or second power device port (530 or 532) is connected to a power bus architecture e.g. power bus (110) shown in Figure 10, while the other of the first and second power device ports is connected to an external DC power device, for example a

power source or power load. In an implementation, either the first or second power device port is connected to a variable voltage power source such as a solar blanket while the other device port is connected to a DC bus architecture. The power node digital data processor configures the reconfigurable power circuit to convert a voltage of a power signal received from the variable voltage source to bus compatible voltage and operates the MPPT module to control the one way DC to DC converter to modulate the amplitude of input current to maintain the power output of the variable voltage power source at an optimized range. Multiple power nodes, each substantially similar to power node (500) can be simultaneously connected to a single external power bus architecture as shown in Figure 10, and can each receive power from the DC power bus infrastructure or deliver power to the DC power bus architecture.

[00182] In a further exemplary configuration (not shown) the first power device port (530) is electrically connected to a first power bus architecture operating a first power bus DC voltage and the second power device port (532) is electrically connected to a second power bus architecture operating at a second power bus DC voltage and the reconfigurable power circuit (400) is operable to convert the first power bus voltage to the second power bus voltage, or the convert the second power bus voltage to the first power bus voltage to autonomously interconnect the two power bus architectures and to autonomously exchange power bidirectionally between the two bus architectures as the power demand and power availability of the two bus architectures are varied.

[00183] It will also be recognized by those skilled in the art that, while the invention has been described above in terms of preferred embodiments, it is not limited thereto. Whereas exemplary embodiments include specific characteristics such as, for example, numbers of device ports, certain bus voltages and voltage ranges, power converter ranges, DC-to-DC power conversion, those skilled in the art will recognize that its usefulness is not limited thereto. Various features and aspects of the above described invention may be used individually or jointly. Further, although the invention has been described in the context of its implementation in a particular environment, and for particular applications (*e.g.* implemented within a power manager), those skilled in the art will recognize that its usefulness is not limited thereto and that the present invention can be beneficially utilized in any number of environments and implementations where it is desirable to selectively connect power devices to a common power bus and to manage power

distributing and minimize power losses due to power conversions or other factors related to power parameters of power devices. Accordingly, the claims set forth below should be construed in view of the full breadth and spirit of the invention as disclosed herein.

WHAT IS CLAIMED

1. A reconfigurable power node comprising:

a first power device port and a second power device port;

a one-way DC to DC power converter comprising an input terminal for receiving input power at a first power amplitude and an output terminal for delivering output power at a second power amplitude;

a plurality of conductive paths each capable of providing bidirectional current flow, the paths including: a first path extending from the first power device port to the input terminal, a second path extending from the output terminal to the second power device port, a third path extending from the first path to the second path, and a fourth path extending from the first path to the second path; and

a plurality of configurable switches including a first configurable switch that is the only configurable switch disposed along the first path, a second configurable switch that is the only configurable switch disposed along the second path, a third configurable switch that is the only configurable switch disposed along the third path, and a fourth configurable switch that is the only configurable switch disposed along the fourth path.

2. The reconfigurable power node of claim 1 further comprising one or more input current sensors for measuring current amplitude along the first path.

3. The reconfigurable power node of claim 1 further comprising one or more output current sensors for measuring current amplitude along the third path.

4. The reconfigurable power node of claim 1 further comprising one or more input voltage sensors for measuring voltage amplitude along the first path.

5. The reconfigurable power node of claim 1 further comprising one or more output voltage sensors for measuring voltage amplitude along the second path.

6. The reconfigurable power node of claim 1 further comprising one or more input current sensors for measuring input current amplitude along the first path and one or more output current sensors for measuring output current amplitude along the third path.

7. The reconfigurable power node of claim 1 further comprising one or more input voltage sensors for measuring input voltage amplitude along the first path and one or more output voltage sensors for measuring output voltage amplitude along the second path.

8. The reconfigurable power node of claim 1 further comprising a housing disposed between the first power device port and the second power device port.

9. The reconfigurable power node of claim 1 further comprising a network communication interface device operable to communicate with another power node.

10. The reconfigurable power node of claim 8 further comprising a rechargeable DC battery disposed inside the housing wherein the rechargeable DC battery delivers charging

power to a digital data processor and an associated memory module and receives recharging power from an external DC power device interfaced with either one of the first power device port or the second power device port.

11. The reconfigurable power node of claim 1 further comprising:

a digital data processor and an associated memory module electrically interfaced with each of the first power device port, the second power device port, the one-way DC to DC power converter, and the first, second, third and fourth configurable switches; and

energy management schema operable on the digital data processor, wherein the energy management schema selectively configures each of the first, second, third and fourth configurable switches to reconfigure the reconfigurable power node as required to exchange power between a first external DC power device connected to the first power device port and a second external DC power device connected to the second power device port.

12. The reconfigurable power circuit of claim 11 further comprising a Maximum Power Point Tracking (MPPT) module operating on the digital data processor wherein the MPPT module is operated to receive power input having a time variable voltage from an external DC power source connected to either one of the first power device port or the second power device port and to an external DC power load connected to the other of the first power device port or the second power device port wherein the power output has a substantially non-variable voltage.

13. The reconfigurable power circuit of claim 12 wherein the MPPT module implements a perturb and observe Power Point Tracking process to track an input power

amplitude as a function of an output current set point of the one one-way DC to DC power converter.

14. The reconfigurable power circuit of claim 11 wherein the one-way DC to DC power converter is operable by the digital data processor and the energy management schema to receive input power from an external DC power device connected with either one of the first power device port and the second power device port, at a first input power voltage amplitude, and to deliver output power to an external DC power device connected with the other of the first power device port and the second power device port, at a second output voltage amplitude, different from the first input voltage amplitude.

15. The reconfigurable power circuit of claim 11 wherein the one-way DC to DC power converter is operable by the digital data processor and the energy management schema to receive input power at a first input current amplitude, at the input terminal, and to deliver output power, from the output terminal, at a second output current amplitude, wherein the second output current amplitude is less than the first input current amplitude.

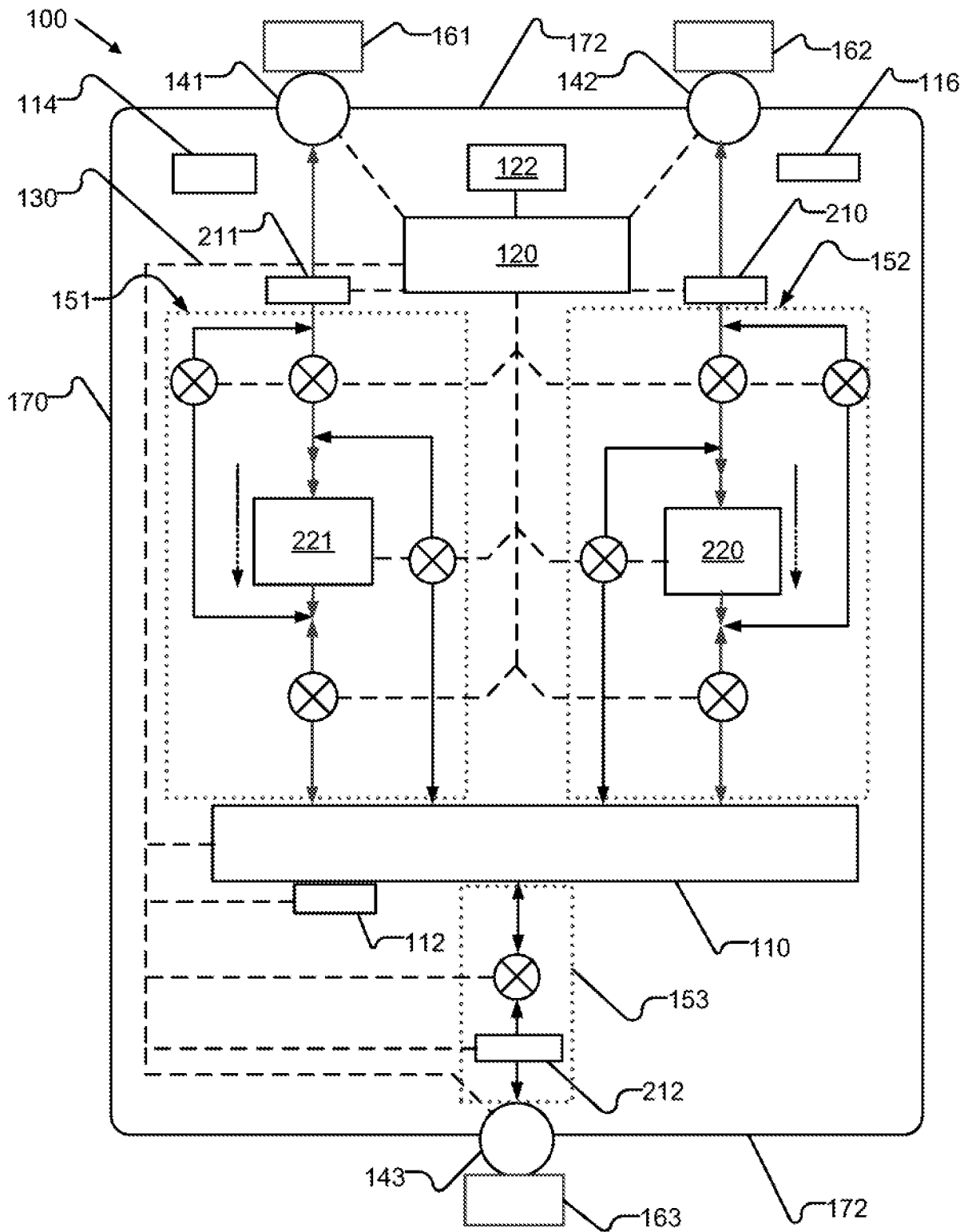

Figure 1

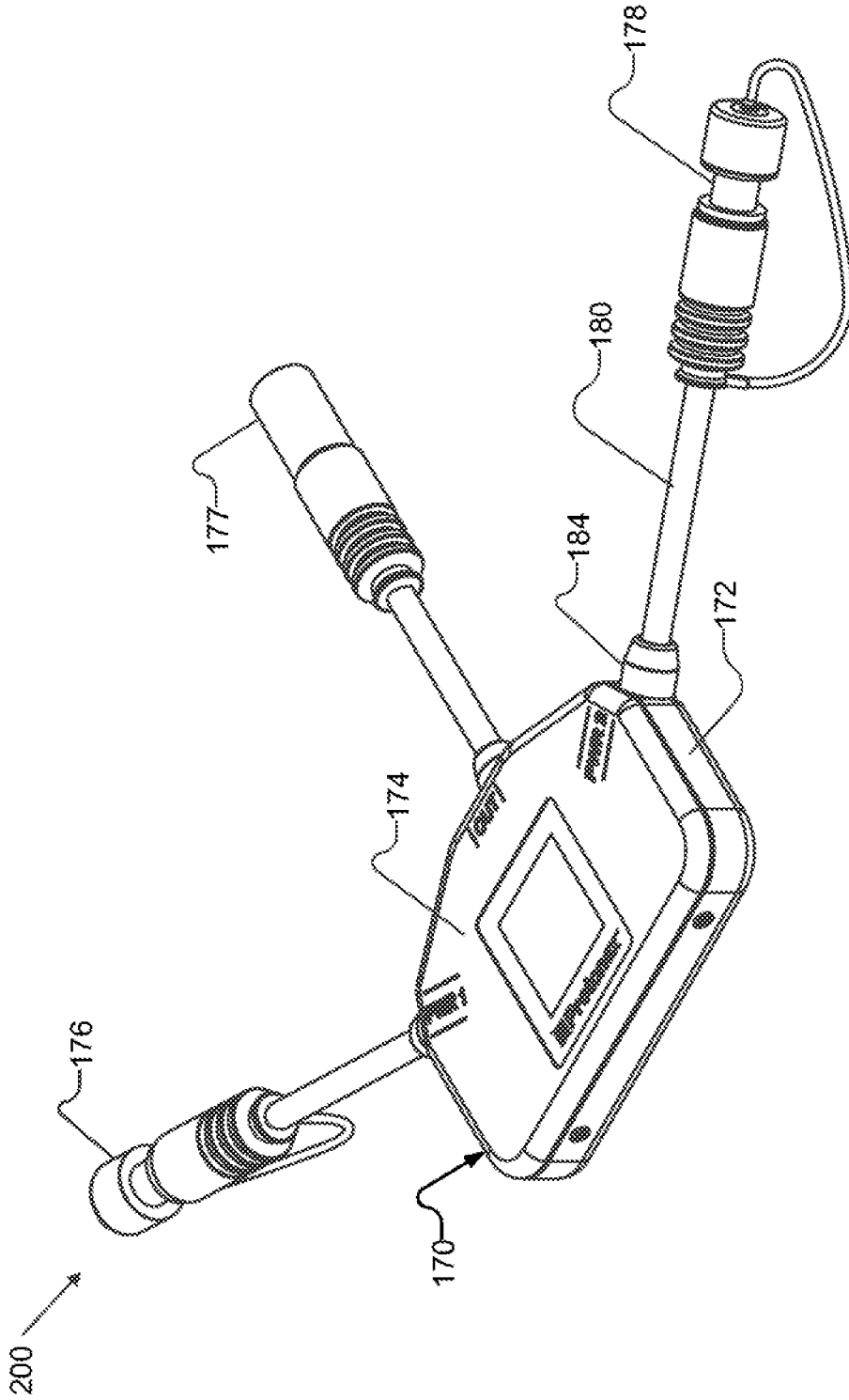

Figure 2

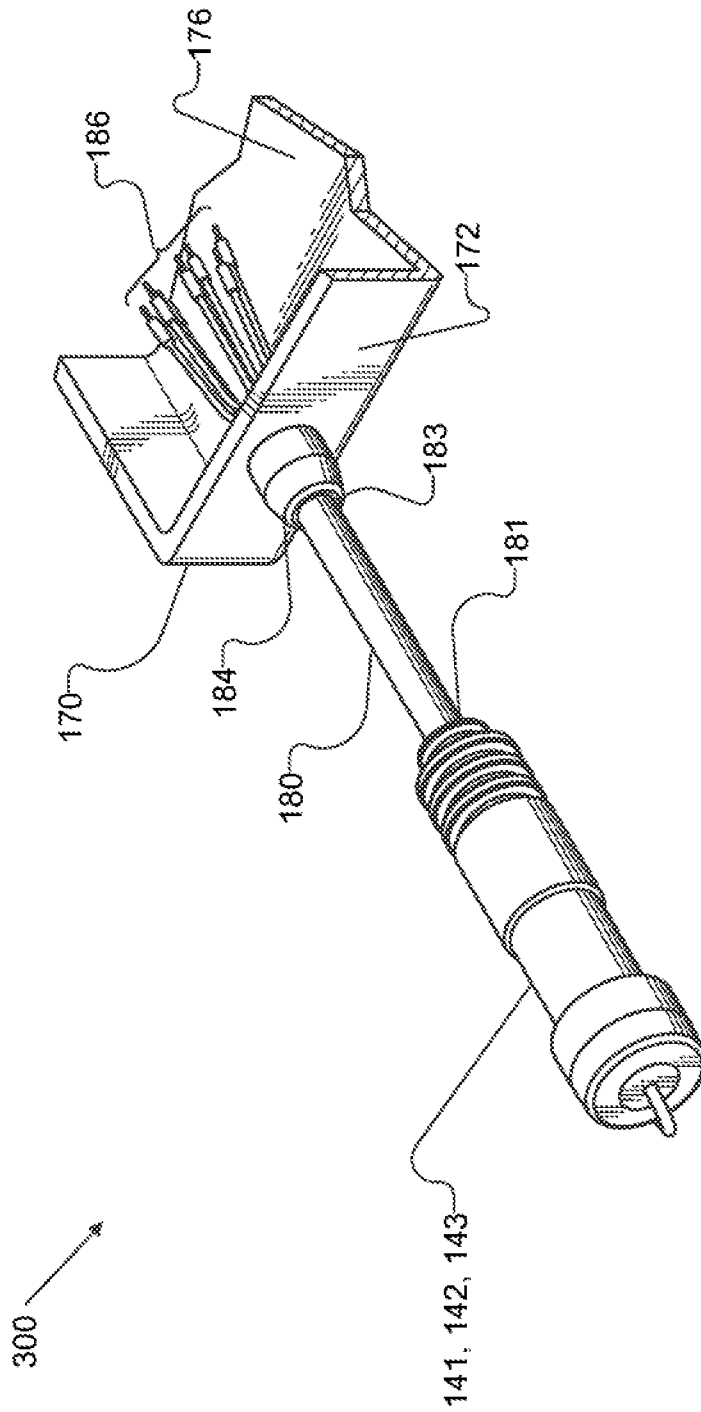

Figure 3

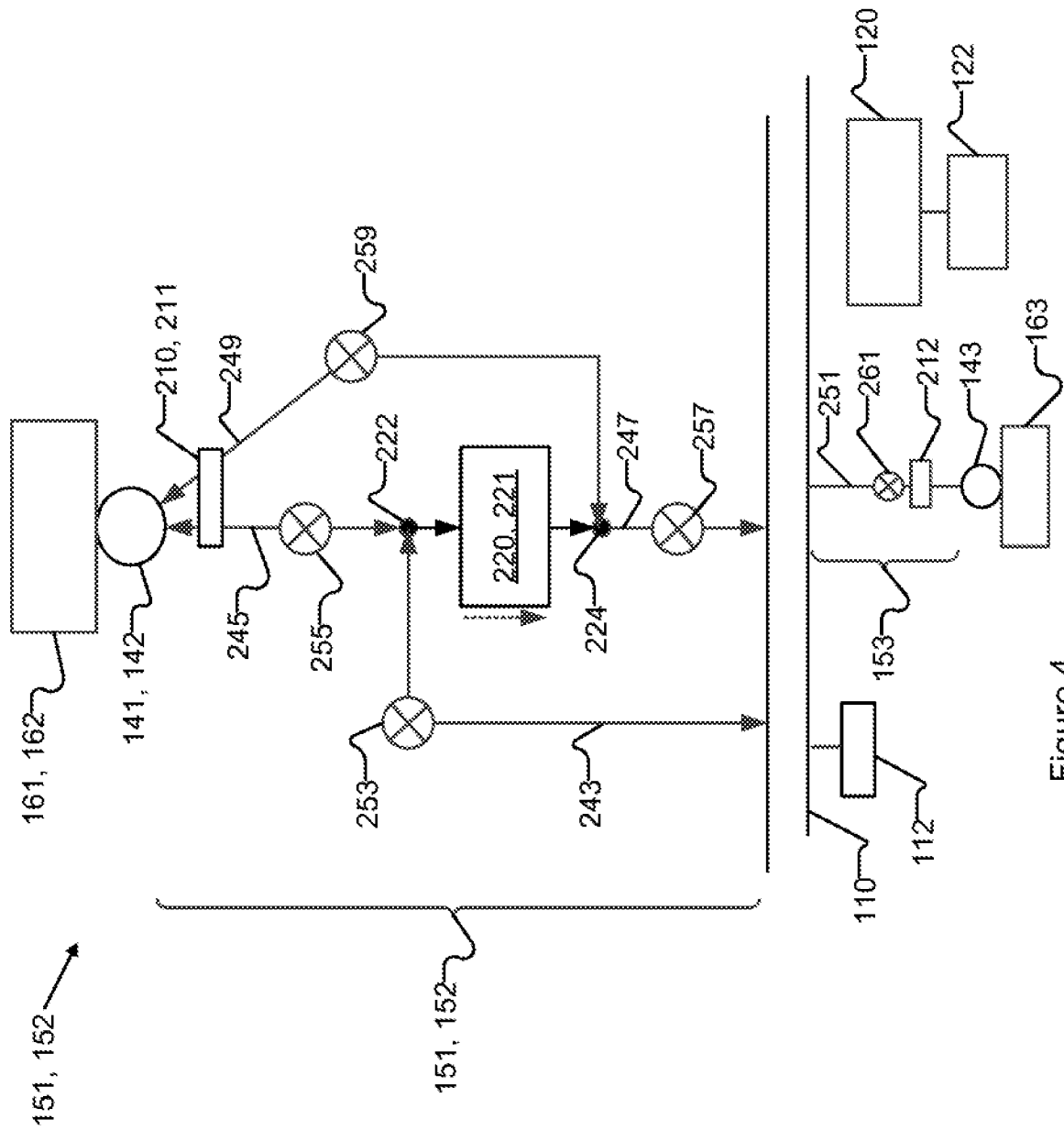

Figure 4

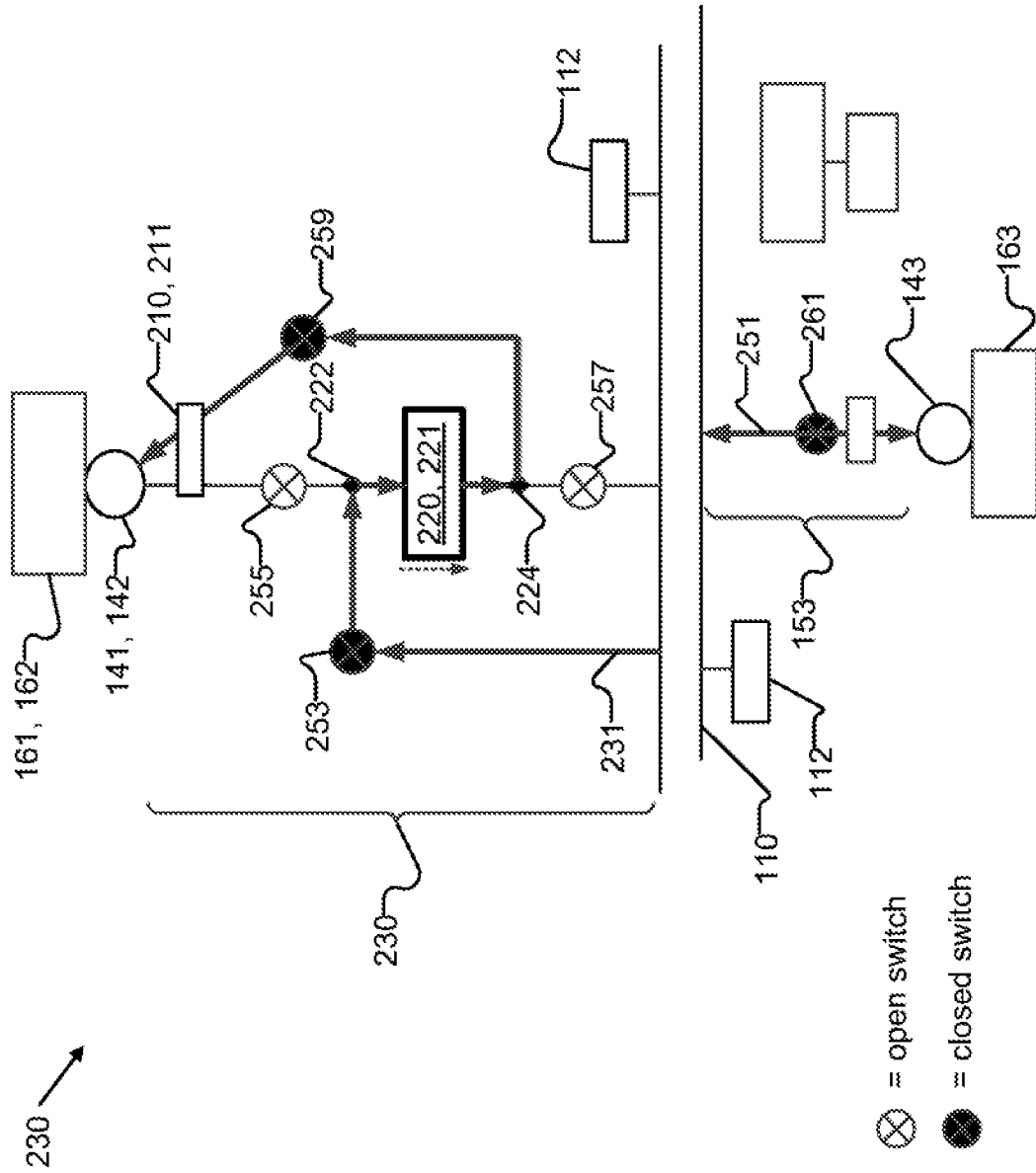

Figure 5

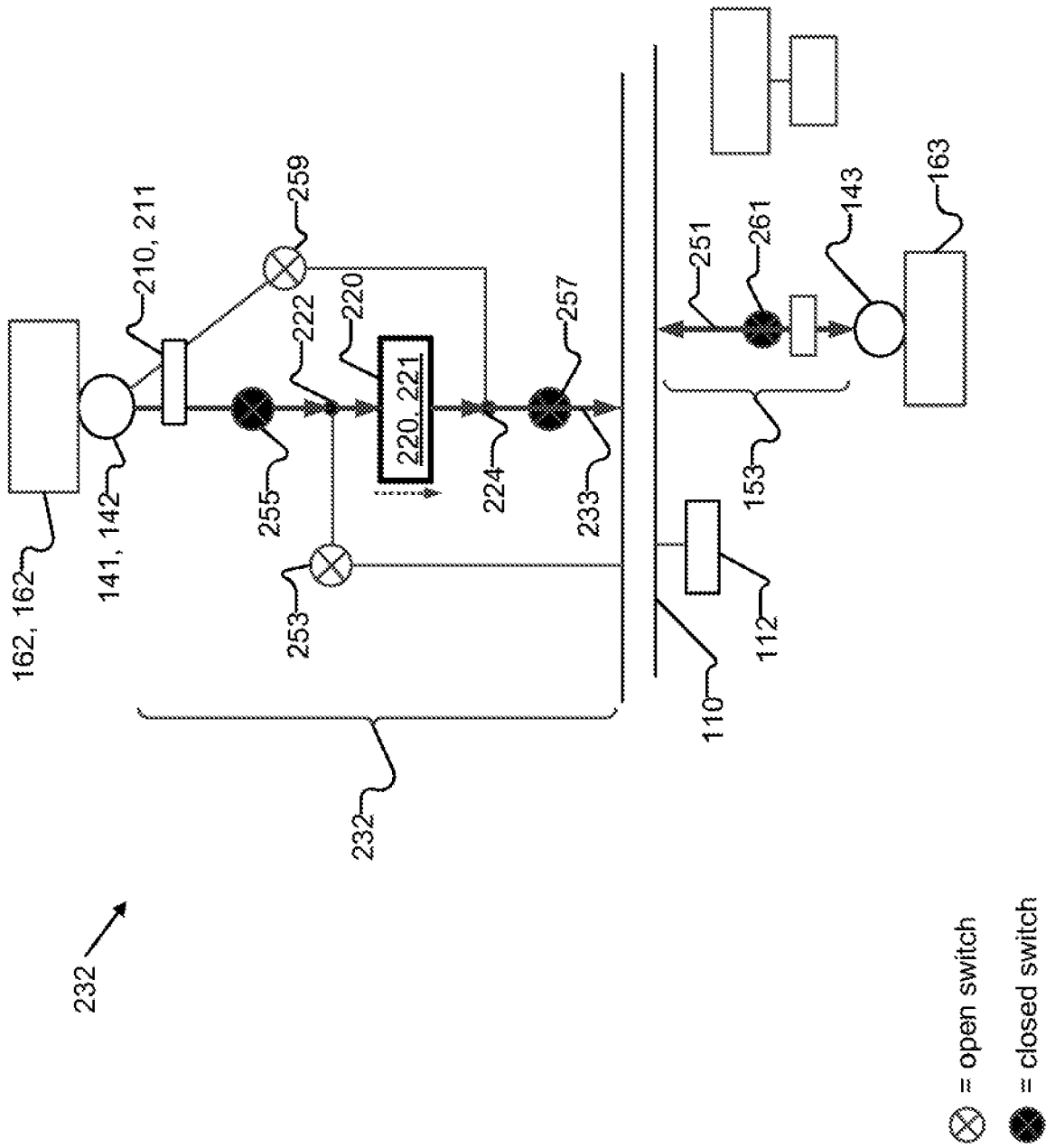

Figure 6

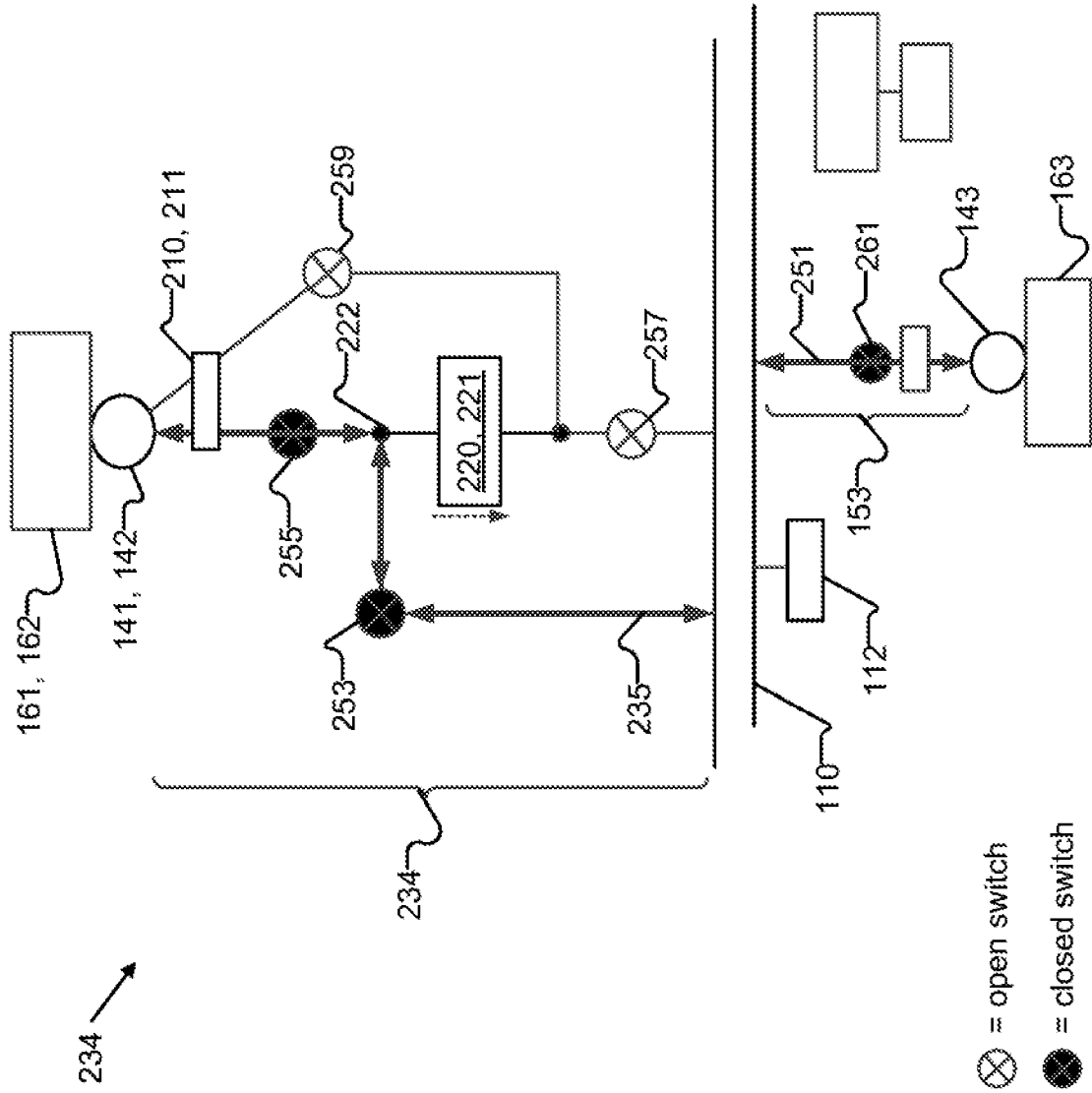

Figure 7

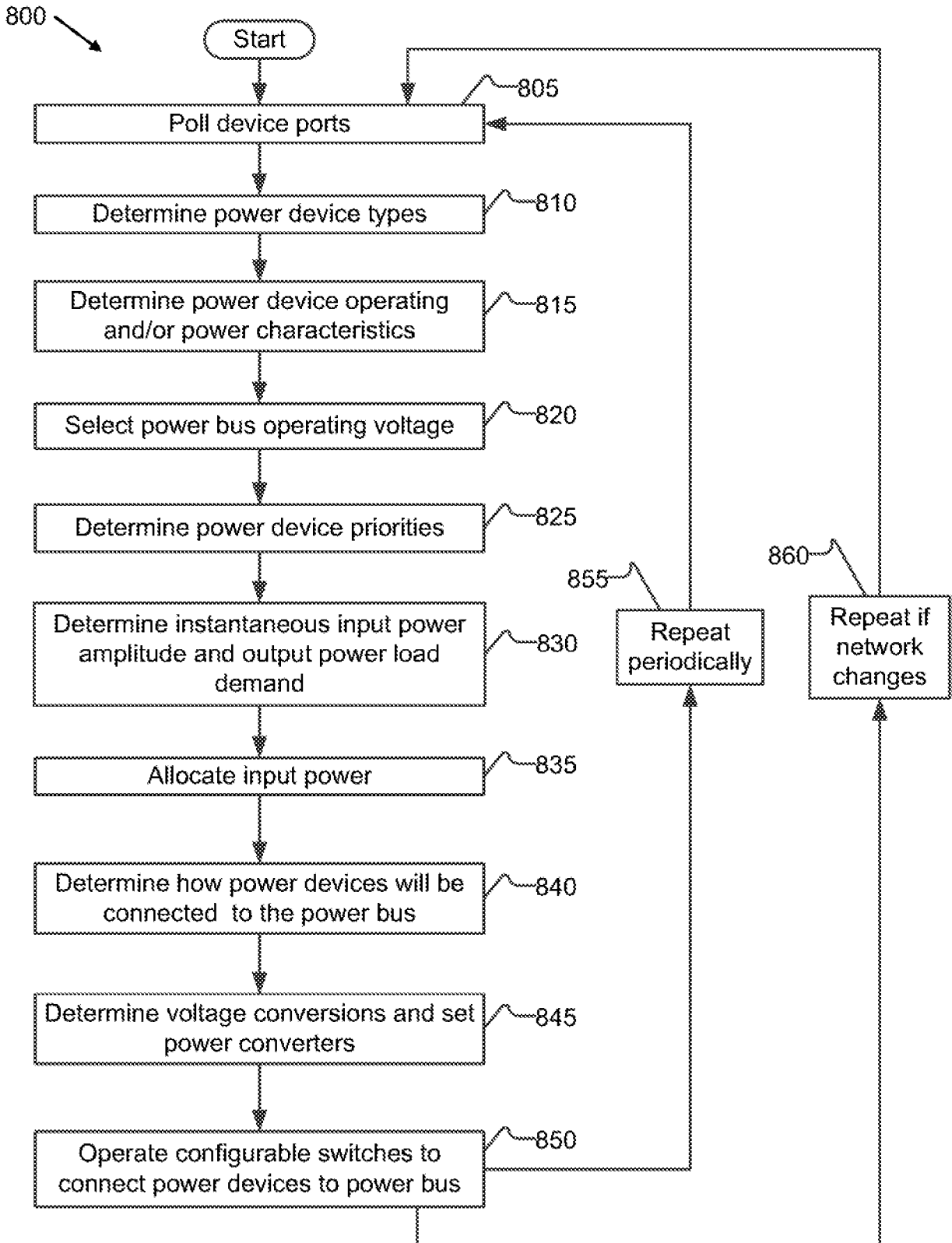

Figure 8

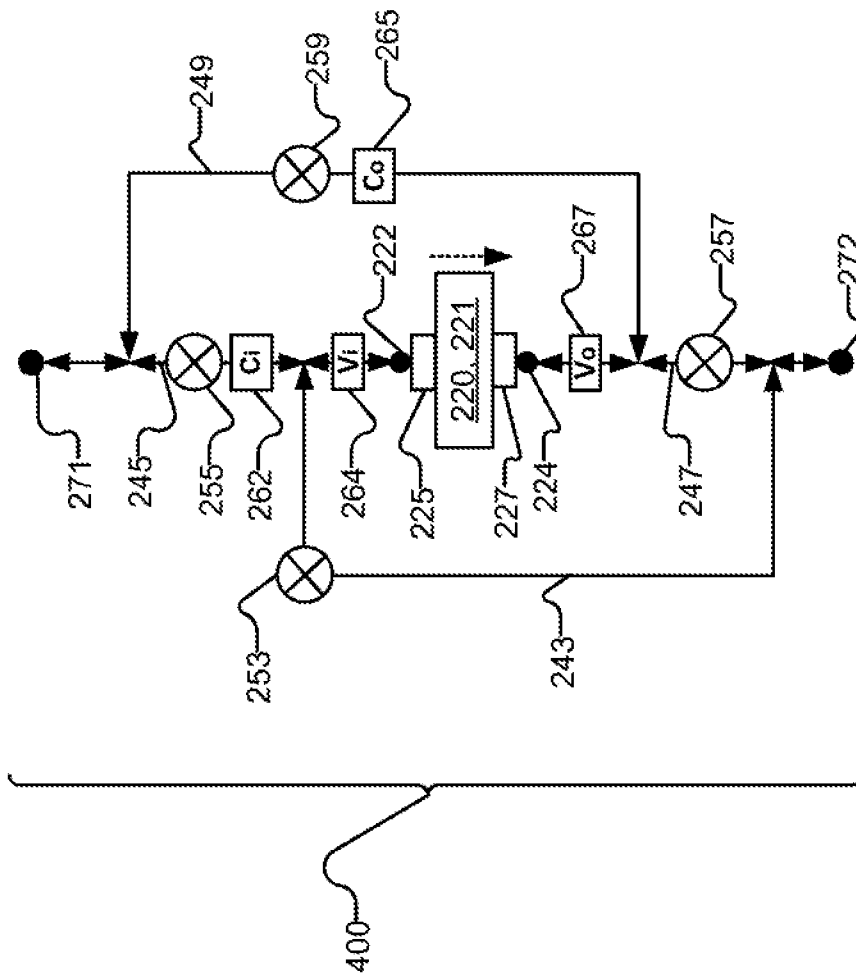

Figure 9a

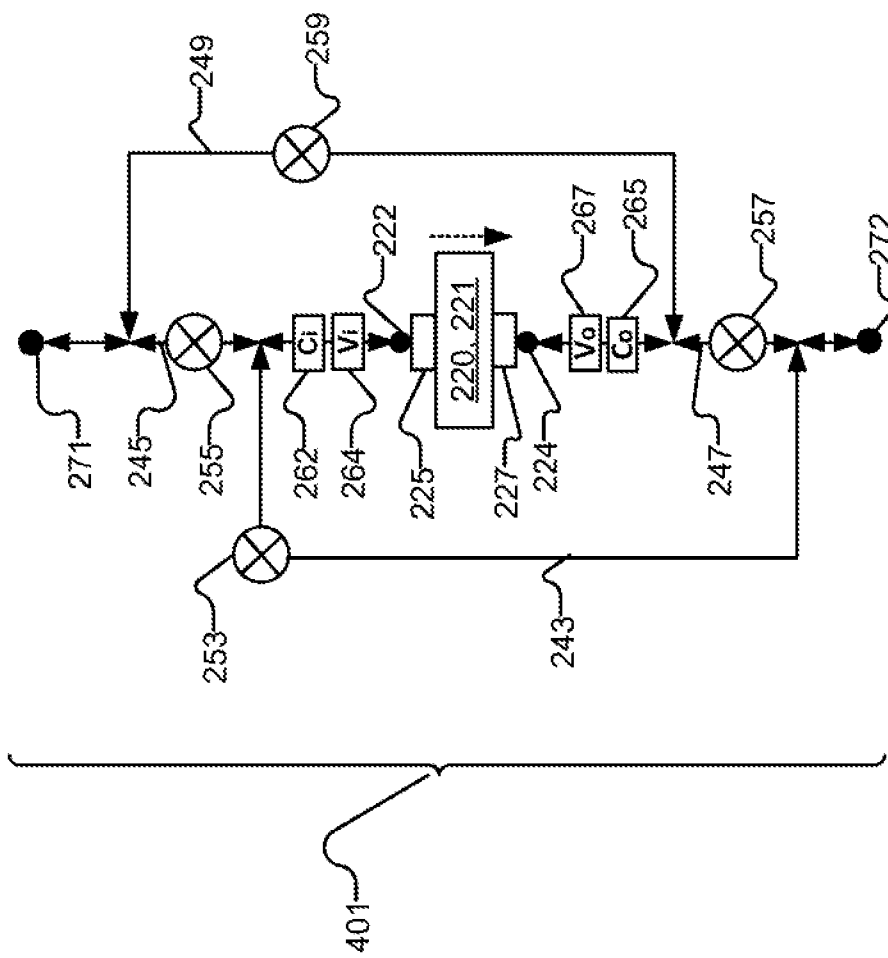

Figure 9b

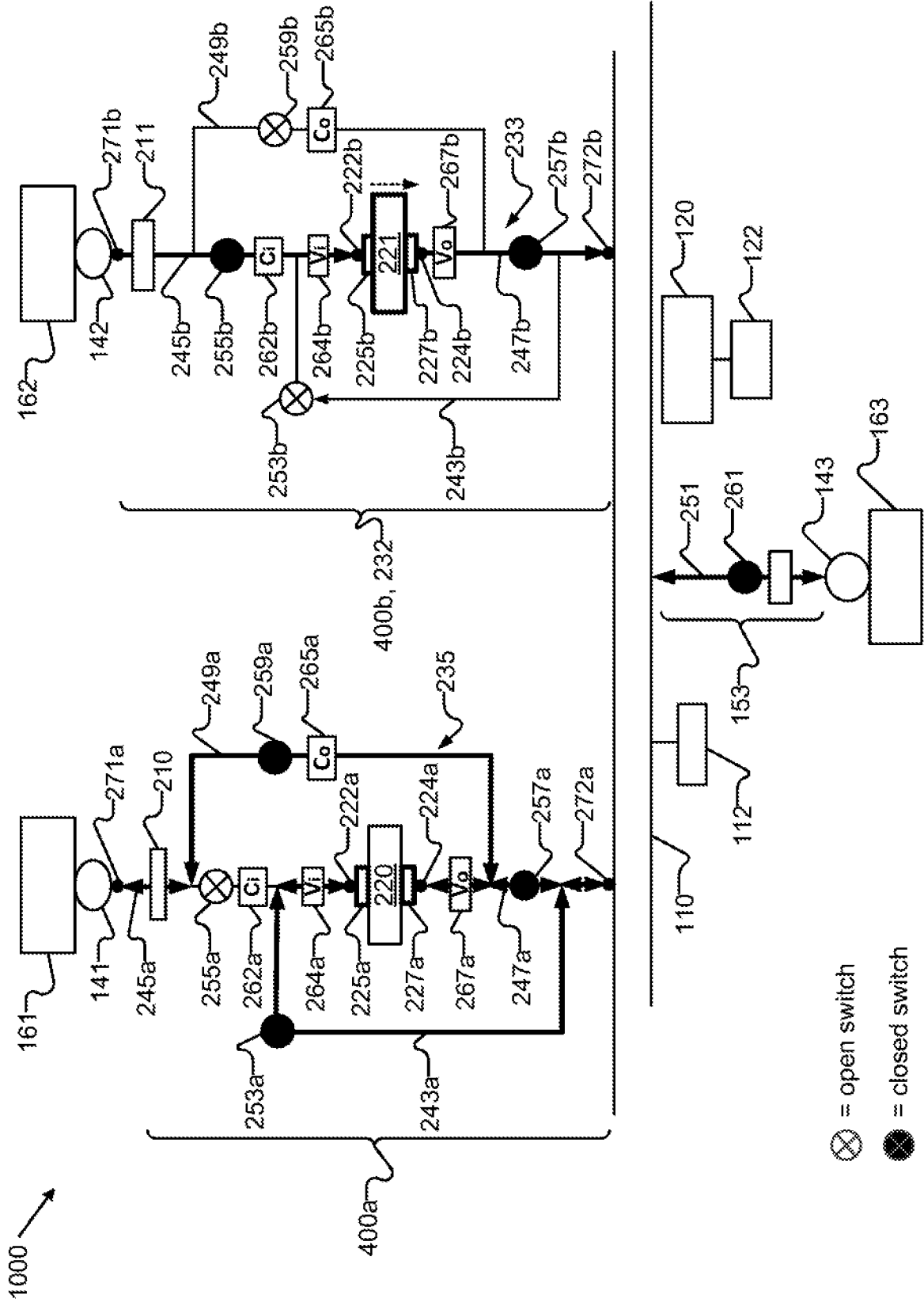

Figure 10

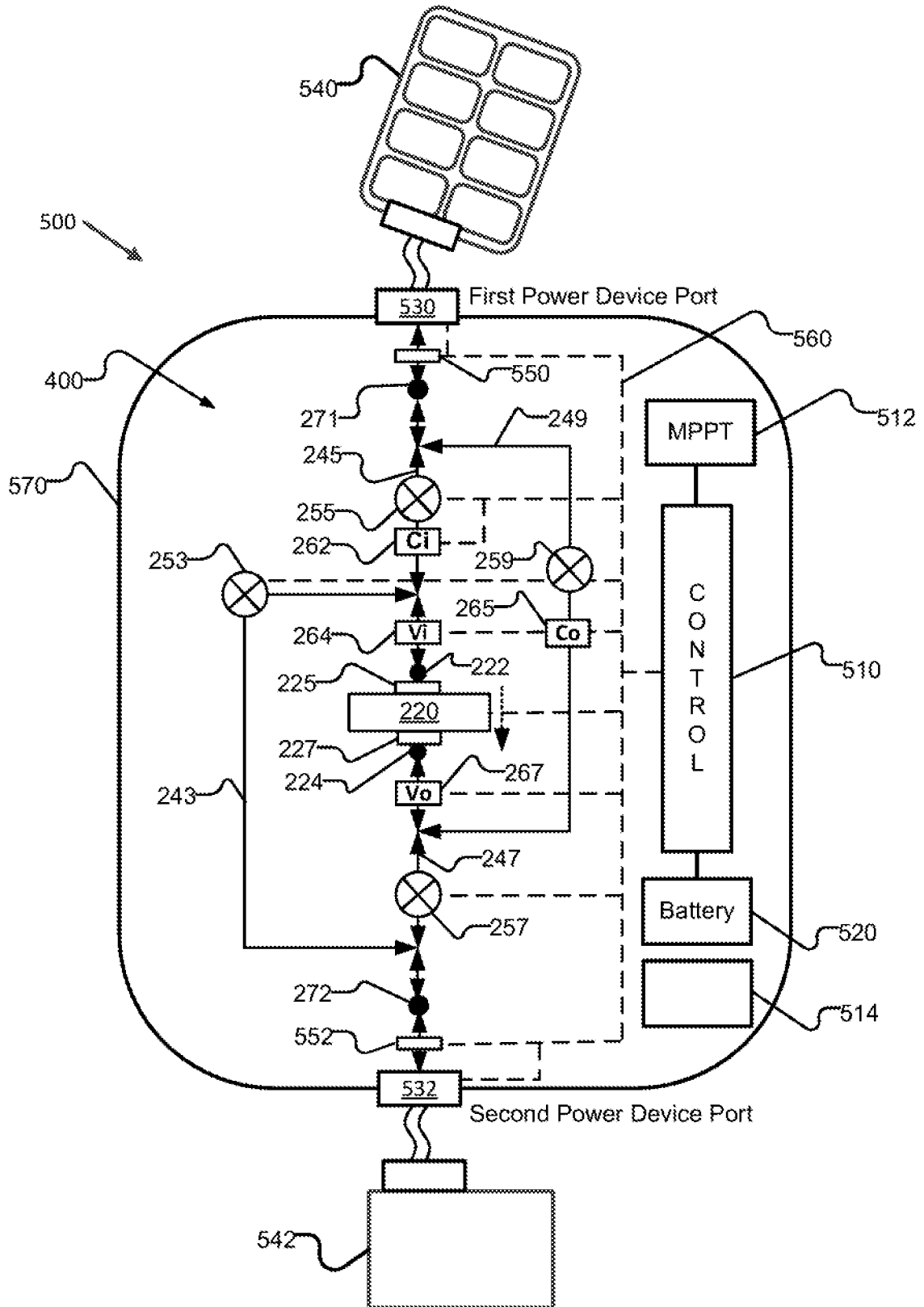

Figure 11

