

(12) INTERNATIONAL APPLICATION PUBLISHED UNDER THE PATENT COOPERATION TREATY (PCT)

(19) World Intellectual Property Organization
International Bureau



(43) International Publication Date
22 March 2001 (22.03.2001)

PCT

(10) International Publication Number
WO 01/20475 A1

- (51) International Patent Classification⁷: G06F 15/16 (72) Inventor: ALON, Amir; 837 Duncardine Way, Sunnyvale, CA 94087 (US).
- (21) International Application Number: PCT/US00/25396 (74) Agents: PISANO, Nicola, A. et al.; Fish & Neave, 1251 Avenue of the Americas, New York, NY 10020 (US).
- (22) International Filing Date:
16 September 2000 (16.09.2000) (81) Designated States (*national*): AU, CA, JP.
- (25) Filing Language: English (84) Designated States (*regional*): European patent (AT, BE, CH, CY, DE, DK, ES, FI, FR, GB, GR, IE, IT, LU, MC, NL, PT, SE).
- (26) Publication Language: English
- (30) Priority Data:
60/154,477 17 September 1999 (17.09.1999) US
- (71) Applicant: SIRENIC, INC. [US/US]; Suite 210, 2350 W. El Camino Real, Mountain View, CA 94040-1456 (US).
- Published:
— With international search report.
- For two-letter codes and other abbreviations, refer to the "Guidance Notes on Codes and Abbreviations" appearing at the beginning of each regular issue of the PCT Gazette.

(54) Title: METHODS AND APPARATUS FOR ACCESSING PERSONALIZED INTERNET INFORMATION USING A MOBILE DEVICE

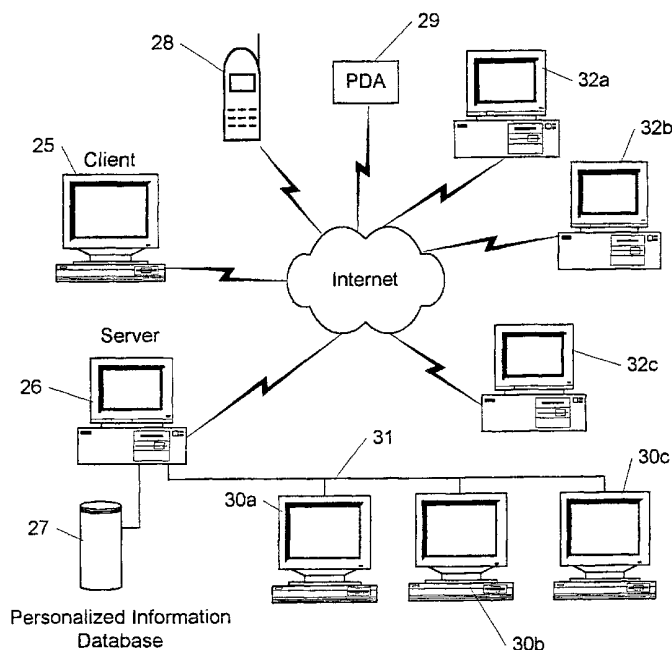

(57) Abstract: Methods and apparatus for accessing personalized information using mobile communications devices are shown. Users access Internet information through an interactive response system (26) from any mobile communications devices (28, 29) by connecting to interacting with the system. The information accessed is personalized for each user, according to user preferences specified in a web page interface for the interactive response system.



WO 01/20475 A1

METHODS AND APPARATUS FOR ACCESSING PERSONALIZED
INTERNET INFORMATION USING A MOBILE DEVICE

Field Of The Invention

5 This invention relates generally to methods
and apparatus for providing access to information
available in the Internet using a mobile device. More
specifically, the present invention provides methods
and apparatus for accessing personalized Internet
10 information using a mobile device such as a telephone.

Background Of The Invention

 The Internet and the World Wide Web
(hereinafter "the web") have revolutionized the ways in
which information is disseminated and shared. A wide
15 variety of information can be simultaneously accessed
by multiple users through a new category of documents
designed to easily represent content for display and
transmission over the Internet. These new documents,
often referred to as *electronic documents* or *web pages*,
20 are increasingly replacing their traditional paper
counterparts as the medium through which business is

-2-

carried out.

A web page is a multimedia composition that is displayed to the user on a "web browser window" by "web browser software". Under the control of a user, 5 the web browser software establishes a connection over the Internet between the user's computer, and a "web server". This connection is used to download data representing a "web page" from the web server to the user's computer. Web pages may contain text, audio, 10 graphics, imagery, and video content, as well as nearly any other type of content that may be experienced through use of a computer or other electronic devices. Additionally, web pages may be interactive, and may contain user selectable links that cause other web 15 pages to be displayed, forms that may be used to send information from the user to the web server, interactive executable code, or other elements through which the user may interact with web pages. A group of one or more interconnected and closely related web 20 pages, such as all the web pages containing information about a single company, located on one or more web servers, is referred to as a "web site".

At present, information displayed on web pages in the Internet can be accessed by various 25 "Internet appliances", which are electronic devices configured with an Internet access system. Internet appliances include, but are not limited to, microprocessor based devices such as personal and portable computers, personal digital assistants, 30 electronic organizers, as well as land line and wireless mobile telephones. In particular, using a wireless telephone to access information available in the Internet has become increasingly popular. The growing demand by mobile business users to have access

-3-

to Internet information from anywhere in the world has led to the development of various Internet telephone access technologies provided by wireless communications providers, such as Sprint Co. from Westwood, KS, and
5 Motorola, Inc., from Schaumburg, IL.

These technologies allow users to access information such as their e-mail, news, stock quotes, among others, by using a *visual interface* in a wireless telephone provided by the wireless communications
10 provider. A visual interface is used in wireless phones that have a small visual display to provide access to Internet information via *microbrowser* software, which consists of a simpler version of a web browser, with reduced graphic capabilities. Users
15 select an information content provider in the Internet from a pull-down menu displayed in the microbrowser window in the wireless telephone. Such content providers include Yahoo! from Santa Clara, CA, Excite from Redwood City, CA, America Online, Inc., from
20 Dulles, VA, as well electronic commerce companies such as Amazon.com from Seattle, WA. The user makes a specific information request to the content provider, and the requested information is then delivered to the user by the microbrowser in the telephone display.

25 Accessing Internet information using a microbrowser in a wireless telephone, however, has several drawbacks. First, it is a very time consuming process, requiring users to select several options in the small visual display in the telephone to access the
30 desired information. The telephone and Internet connections may be unreliable, or the user may have to wait a significant amount of time to receive the requested information. Second, interacting with the visual interface in the telephone is extremely tedious.

-4-

An inordinately large number of telephone key presses may be required to retrieve even a small amount of useful information. The visual interface has to be managed on a telephone with difficult to use controls.

5 Lastly, the existing microbrowser systems do not provide access to concise, relevant, and important information quickly and easily. Different pieces of information are often relevant to different users, and users may have to iterate through several items of less

10 important and less interesting information before accessing desired information.

One alternative way to access information using a telephone is provided by *interactive voice response* (IVR) systems. These systems enable the

15 telephone user to access information by dialing a phone number corresponding to an IVR system server. The server contains software to issue voice prompts to the user corresponding to several information access options, and the user responds to the voice prompts by

20 either selecting and pushing buttons on the telephone, or by using speech recognition technologies. Users can access IVR systems from any standard telephone, including those that do not have visual displays. Examples of IVR systems include those employed by

25 financial institutions to give users access to their accounts over the telephone, such as the system covered in U.S. Patent Number 5,825,856. Similar systems are also employed in a host of other applications, including those in the airline industry offering users

30 the ability to check flight information over the telephone. IVR systems are very easy to use, and provide quick access to information from any telephone with a simple phone call.

Information can also be accessed by several

-5-

other mobile devices, such as personal digital assistants (PDAs) and pagers. In this case, the IVR system may be substituted by an interactive response (IR) system in which the voice prompts are replaced
5 with text in a small visual display window in the mobile device. An example includes the two-way word messaging feature offered by Motorola, Inc., from Schaumburg, IL.

In view of the foregoing drawbacks of
10 accessing Internet information using a microbrowser in a telephone, it would be desirable to provide methods and apparatus for accessing information in the Internet using an IR system and a mobile communications device (MCD).

15 It would further be desirable to provide methods and apparatus for accessing e-mail, fax, voice mail information, calendar, and specific items on web sites using an IR system and a MCD.

It would also be desirable to provide methods
20 and apparatus for creating a personalized information database to store each user's personalized information to be accessed using an IR system and a MCD.

Summary Of The Invention

25 In view of the foregoing, it is an object of the present invention to provide methods and apparatus for providing access to personalized Internet information using an IR system and a MCD.

It is another object of the present invention
30 to provide methods and apparatus for accessing e-mail, fax, voice mail information, calendar, and specific items on web sites using an IR system and a MCD.

It is a further object of the present invention to provide methods and apparatus for creating

-6-

a personalized information database to store each user's personalized information to be accessed using an IR system and a MCD.

These and other objects of the present invention are accomplished by providing methods and apparatus for accessing personalized Internet information using an IR system and a MCD. The personalized information may include e-mail, fax notification, calendar, "to do" lists, as well as specific items on favorite web sites.

In a preferred embodiment, the methods of the present invention for providing personalized access to Internet information using an IR system and a MCD involve three steps: (1) creating a web page to provide an interface for personalizing the information to be accessed using the IR system; (2) creating a personalized information database to store the personalized information selected by the user to be accessed using the IR system; and (3) designing an IR system to provide access to the personalized information stored in the personalized information database.

More specifically, a personalization routine generates a web page interface that enables users to specify and update personal information preferences that are accessed using the IR system and the MCD. The personalized information preferences are selected by creating specially designed "scripts", which are programs generated when users select personalized information for several information categories, such as e-mail, financial information, and news. The scripts contain the steps required for users to access their personalized information for a specific information category and are executed each time the user requests

-7-

the personalized information in that category using the IR system. The user requests personalized information for a specific information category by connecting to the IR system and selecting one or more information
5 categories to be downloaded to the MCD. The scripts are stored in a personalized information database provided in the web server.

Advantageously, the present invention enables a user to access Internet information quickly and
10 easily using an IR system from any MCD.

In addition, the present invention enables a user to select the information accessible using the IR system according to his or her personal preferences.

15 Brief Description Of The Drawings

The foregoing and other objects of the present invention will be apparent upon consideration of the following detailed description, taken in conjunction with the accompanying drawings, in which
20 like reference characters refer to like parts throughout, and in which:

FIG. 1 is a schematic view of a computer system suitable for use with the present invention;

FIG. 2 shows the network environment in which
25 the present invention operates;

FIG. 3 is a flow chart for accessing personalized information with an illustrative embodiment of the present invention in which the MCD is a telephone and the IR system is an interactive voice
30 response (IVR) system;

FIG. 4 illustrates an example list of information categories to be accessed using the IR system;

FIG. 5 is a schematic view of a web page

-8-

interface for users to select the personalized information to be accessed with the IR system;

FIG. 6 is a schematic view of a preferred embodiment of an interactive web page for specifying
5 the "favorites" information category;

FIG. 7A is a flow chart for selecting information from a web site in the "favorites" information category to be accessed using the IR system;

10 FIG. 7B shows an example web site in the "favorites" information category containing an item selected for access using the IR system;

FIG. 8A is a schematic view of a preferred embodiment of an interactive web page for specifying
15 the "messages" information category;

FIG. 8B shows an example message window displayed on the interactive web page for specifying the "messages" information category; and

FIG. 9 shows an example text transcript of
20 user access to an illustrative embodiment of the present invention in which the MCD is a telephone and the IR system is an IVR system.

Detailed Description Of The Invention

The present invention provides access to
25 personalized Internet information using an IR system and a mobile communications device (MCD). The MCD, as used herein, may be a telephone, a personal digital assistant (PDA), a pager, or any other mobile device that provides access to the Internet. An IR system
30 enables a user to access information by connecting to an IR system server. The server contains software to issue prompts to the user corresponding to several information access options, and the user responds to

-9-

the prompts by either selecting icons or pushing buttons on the MCD, or, if the MCD is a telephone, by using speech recognition technologies. Users therefore can access IR systems from any standard MCD, including
5 those that do not have visual displays.

Referring to FIG. 1, a computer system suitable for use with the present invention is described. Computer system 20 includes at least processor 21, for processing information according to
10 programmed instructions, memory 22, for storing information and instructions for processor 21, and storage system 23, such as a magnetic or optical disk system, for storing large amounts of information and instructions on a relatively long-term basis. Memory
15 21 contains instructions for web browser software to access a web page interface on which users select personalized Internet information to be accessed using an IR system. Processor 21, memory 22, and storage system 23 are coupled to bus 24, which enables devices
20 connected to bus 24 to communicate with each other.

It will be apparent to one of ordinary skill in the art that computer system 20 is illustrative, and that alternative systems and architectures may be used with the present invention. It will further be
25 understood that many other devices, such as a display system (not shown), a network interface (not shown), and a variety of other input and output devices (not shown) may be included in computer system 20.

Referring now to FIG. 2, an overview of the
30 network environment in which a preferred embodiment of the present invention operates is presented. Client computer 25 ("client") uses web browser software to communicate across the Internet with IR server 26 (herein referred to as "server"). Server 26 executes

-10-

web server software to process requests from client computers on the Internet. Server 26 responds to these requests by sending web pages to client 25, such as the web page interface on which users select the
5 personalized information to be accessed using the IR system.

In accordance with the present invention, server 26 also generates "information category software scripts" (herein referred to as scripts) that contain
10 the steps required for a user to access his or her personalized information for a specific information category. The scripts are generated when client 25 sends requests to server 26 to select personalized information in a specific information category via the
15 web page interface displayed in client 25. Server 26 contains personalized information database 27 to store the scripts generated for all users having access to the system. Users are granted access to the IR system by establishing user accounts in the web page interface
20 displayed in client 25. The scripts are executed each time an user accesses the IR system. The IR system is accessed by connecting to the IR system using a MCD, such as for example, telephone 28 or personal digital assistant 29. Requests are sent to server 26 to
25 execute the scripts stored in personalized information database 27 by keying in commands using the input pad of telephone 28 or PDA 29. Alternatively, commands could be entered in the form of voice prompts from a user of telephone 28.

30 Additionally, server 26 may contain "search engine" software for locating web pages in the Internet. Server 26 also may handle database management tasks, as well as a variety of administrative tasks, such as compiling usage

-11-

statistics. Alternatively, some or all of these tasks may be performed by computers 30a-c, connected to server 26 through local area network 31. It will be understood by one skilled in the art that there are
5 large numbers of web servers connected to the Internet, and large numbers of client computers running web browser software. If server 26 has sufficient capacity, at any given time it may be in communication with thousands of client computers.

10 Web servers 32a-c are computers that provide access to web pages that may be found through use of a search engine provided by server 26. When a user of client 25 selects a web page that runs on one of the web servers 32a-c from the search engine results
15 provided by server 26, client 25 may communicate across the Internet with one of web servers 32a-c.

Further, one skilled in the art will understand that the present invention also could be used in other network settings. For example, rather
20 than connecting through the Internet, the apparatus and methods of the present invention could be used on a local area network. In such a configuration, the clients and server would all be connected to the same local area network.

25 Referring to FIG. 3, a flowchart for accessing personalized information with an illustrative embodiment of the present invention in which the MCD is a telephone and the IR system is an interactive voice response (IVR) system is described. At step 34, the
30 user dials the number to access the IVR system server using a telephone. A telephone connection is established between the user's telephone and the server, and the user is greeted with voice commands to notify the user of any important messages or useful

-12-

information according to the users' preferences, and to inform the user that information is ready to be accessed. At step 35, the user selects the desired information category by selecting the appropriate
5 buttons on the telephone keypad or by issuing voice commands. A request for information is then sent to the server, and at step 36, the server executes the appropriate script corresponding to the information category selected by the user to fetch the user's
10 personalized information from the Internet. The scripts corresponding to all information categories for each user of the IR system are stored in a personalized information database in the server. The personalized information is translated into voice commands at step
15 37, and the voice commands are transmitted to the user at step 38. At step 39, the user decides whether to access additional information categories, and if so desired, the process described above is repeated, starting from step 35.

20 Referring now to FIG. 4, an example list of information categories that may be accessed using the IR system is described. Information categories 41a-i may be accessed by the user by entering the appropriate commands using an input device, such as a keypad or a
25 menu, or by using voice prompts in the case of a telephone. Information categories 41a-i include: messages (41a), quotes (41b), news (41c), weather (41d), sports (41e), favorites (41f), address book (41g), calendar (41h), and downloads (41i). The
30 selection of an information category will trigger the execution of a script in the server that fetches the user's personalized information in that category from the Internet. The server stores a list of scripts associated with each information category for each user

-13-

of the IR system. The scripts are stored in the personalized information database in the server. It will be understood by one skilled in the art that different information categories may be included with
5 the present invention.

Message category 41a provides access to a unified messaging system, enabling the user to receive e-mails, fax notification, and voice mail via the MCD. All the e-mails and voice mail messages received by the
10 user can be deleted, skipped to the next message, saved, and played multiple times. For example, if the MCD is a telephone, an e-mail reply may be sent to the server as a compressed audio file to the appropriate e-mail address. Fax notifications also may be sent to
15 the user in the form of a fax header and sender details that are read to the user by the server. The user has the option to review the fax header, skip to the next fax, delete the fax, and forward the fax to a fax number. In addition, the user can use the MCD input
20 device to select fax, phone, and e-mail addresses through which the user can be contacted. For example, the "@" and "." characters used in e-mail addresses may be specified with the "*" key of the telephone keypad.

Quotes category 41b provides access to a
25 stock portfolio maintained by the user. The user can receive stock quotes or be notified of relevant movements in the stock market in accordance with specified preferences selected by the user when accessing the web page interface. News category 41c
30 provides access to preferred news web sites in the Internet. Users also can be notified of specific news according to information preferences stored in the personalized information database in the server. Similarly, weather category 41d and sports category 41e

-14-

provide access to selected weather and sports information, respectively. The selected information is specified in the corresponding scripts stored in the personalized information database in the server.

5 Favorites category 41f provides a list of selected web sites according to the user's preferences. Upon selecting a web site from the list provided in favorites category 41f, the script corresponding to favorites category 41f for the user is executed by the
10 server. The script corresponding to favorites category 41f performs the actions required to access the web site and extracts desired information from the web site to be sent to the user. The server packages the desired information into the appropriate format for the
15 MCD, and the user may browse the information in the web site by entering appropriate commands using the MCD input device. The desired information from the web site is specified by the user when interacting with the web page interface. The user has the option to select
20 all the information or only specific fields of information from any given web site. For example, consider the web site for Amazon.com of Seattle, WA. The user can specify in the web page interface that only the week's best-seller list is to be sent to the
25 user when the Amazon.com web site is selected from favorites category 41f.

In addition, address book category 41g and calendar category 41h enable users to access their address book and calendar, respectively, using the IR
30 system. Downloads category 41i allows users to specify where data files downloaded from web sites are to be stored in the server.

Referring now to FIG. 5, a schematic view of a web page interface for personalizing user information

-15-

to be accessed with the IR system is described. Web page interface 42 may be accessed by users in any client computer with web browser software by specifying the web address of web page interface 42. Web page interface 42 preferably contains at least user account field 43 and information category field 44. User account field 43 is accessed by a first-time user of the IR system to create an account, and by a returning user of the IR system to specify his or her account.

10 Creating an user account involves: (1) selecting a connection address, e.g., a phone number, to be used when accessing the IR system, (2) selecting a password for accessing the web page interface in a secure manner, (3) entering personal user information such as

15 user's address and zip code, and (4) selecting a service plan with corresponding billing options. The user's address and zip code are used in the customization of local news and weather reports. Users can select from a variety of service and billing

20 options, to specify any rates incurred when accessing the IR system. Upon creating the user account, any subsequent access to web page interface 42 will require the user to enter the selected password in user account field 43.

25 Information category field 44 displays all the information categories available for user access with the IR system. Each information category in information category field 44 is a user selectable link, that when clicked, causes an interactive web page

30 to be displayed. Information category field 44 contains 9 user selectable information links, each information link corresponding to a given information category: (1) messages link 44a, (2) quotes link 44b, (3) news link 44c, (4) weather link 44d, (5) sports

-16-

link 44e, (6) favorites link 44f, (7) address book link 44g, (8) calendar link 44h, and (9) downloads link 44i. Each information link points to an interactive web page that enables users to specify the desired information to be transmitted when a given information category is selected by the user when accessing the IR system. First-time users of the IR system may click on the links in information category field 44 to specify the information to be transmitted over the IR system. Additionally, a returning user of the IR system may click on information links 44a-i any time to update preferences regarding the information transmitted through the IR system. When a user specifies or updates his or her information access preferences for a given information category, the server generates a script containing the steps required for that user to access his or her information preferences for a given information category. Scripts are created for all information categories and stored in the personalized information database in the server.

Messages link 44a points to an interactive web page that provides users with a unified messaging system. The unified messaging system allows users to specify e-mail addresses, phone, fax, and page numbers to be used as returning and forwarding points of contact by the IR system. The unified messaging system further enables users to specify actions to be performed when certain messages are received. For example, a user may want to be alerted any time an e-mail is received, or to forward all e-mail messages relating to a stock portfolio to a special file folder.

Quotes link 44b points to an interactive web page that allows users to specify the stock quotes and stock market indexes desired to be transmitted by the

-17-

IR system. The user also may assign a priority to a number of stock quotes so that an alert is sent to the user by the IR system any time the stock quote goes above or below a certain price. News link 44c points
5 to an interactive web page that allows users to specify favorite news sources and news topics for access with the IR system. Similarly, weather link 44d and sports link 44e point to interactive web pages that allow users to specify desired weather information and sport
10 scores to be accessed with the IR system.

Favorites link 44f points to an interactive web page that allows users to select a list of preferred web sites to be accessed with the IR system. The user has the option to select all the information
15 or only specific fields of information from any given web site to be accessed with the IR system. Lastly, address book link 44g, calendar link 44h, and downloads link 44i point to interactive web pages that allow users to specify an address book, a calendar, and file
20 download information to be accessed using the IR system.

Referring now to FIG. 6, a schematic view of a preferred embodiment of an interactive web page for specifying the favorites information category is
25 described. Interactive web page 45 allows users to select a list of preferred web sites to be accessed with the IR system. The web sites can be listed individually, such as personal web sites 46a-c (denoted by the letter "P"), or in a folder, such as web sites
30 47a-b (denoted by the letter "F"). A set of control buttons is provided in the web page interface for users to update the list of web sites that may be accessed using the IR system. Control buttons 48, 49, 50, and 51, enable users to delete, add, edit, or specify a new

-18-

favorite web site or folder in the list of preferred web sites, respectively. It will be understood by those skilled in the art that different control buttons may be included in the web site.

5 When add control button 49 is clicked by an user, the user is prompted with a new browser window to specify the desired web site to be added to the list. The user then may select the specific fields of information from the web site that are to be accessed
10 using the IR system. The selection process involves the use of specific control keys to mark the desired information fields in the web page. Edit control button 50 may be clicked by an user any time an update to the selected information fields from a given web
15 site in the list is desired. Web sites or folders can be removed from the list by clicking on delete control button 48, and new web sites or folders may be included in the list by clicking new control button 51.

 Referring now to FIG. 7A, a flow chart for
20 selecting information from a web site in the favorites information category to be accessed using the IR system is described. At step 53, the user clicks on add control button 49 (see FIG. 6) to add a new favorite web site to the favorites information category. Upon
25 receiving the user's request, the server starts creating a script corresponding to the favorite web site selected at step 54. The script records the actions required to access the desired information for the given favorite web site. When the favorite web
30 site is accessed by the user through the IR system, the server simply executes the script corresponding to the favorite web site for that particular user.

 At step 55, the user browses the selected web site to determine what information displayed in the web

-19-

site may be accessed using the IR system. At step 56, the user selects the desired information from the web site to be accessed through the IR system by using a set of control keys to mark the information in the web site. The control keys are used to draw a rectangular box around the desired information to be accessed. Once the rectangular box is drawn, an "alert trigger" pop-up window is displayed so that the user can determine specific items in the information selected that are given higher access priority. Alert triggers are higher priority information conveyed to an user when the IR system is accessed. When users connect to the IR system, the first information they are presented is the alert triggers, followed by a menu of options to prompt the user for access to the information categories.

The user can specify the information items that are to be assigned higher priority as well as the delivery mechanism for receiving the alert, including e-mail, fax notification, or by phone, at step 57. For example, users may want to be alerted of special airline promotions for particular destinations when accessing a favorite airline web site. Lastly, at step 58, the server records the actions performed by the user when selecting the information from the web site to be included in the favorites information category. Any future changes to this category are updated in the script. The script is executed any time the user accesses this category through the IR system.

Referring now to FIG. 7B, an example web site in the favorites information category containing an item selected for access using the IR system is described. Web site 60 is a personal "My Yahoo" site from Yahoo!, Inc., of Santa Clara, CA, containing

-20-

information targeted for a particular user, such as news headlines and stock portfolios. Web site 60 is displayed on a web browser window in the user's computer. Web site 60 includes stock portfolio 61 that
5 is selected by the user as the information item from the web site to be accessed through the favorites information category using the IR system. Stock portfolio 61 is selected when the user draws a rectangular box around the information displayed in
10 stock portfolio 61 using the computer mouse and special control keys. This action triggers the server to display alert pop-up window 62 in the user's computer. Alert pop-up window 62 contains interactive user windows 63 and 64 for the user to specify which items
15 inside the rectangular box drawn around stock portfolio 61 are to be given higher priority by the IR system (user window 63), and how the alert is to be delivered to the user (user window 64). The user specifies this information by placing the mouse cursor inside user
20 windows 63 and 64 and typing the information directly in the windows. As shown in the example, the user may specify a stock quote such as "YHOO" to be assigned higher priority, causing the IR system to alert the user by phone any time this stock quote goes above 150.

25 Further, it will be understood by one skilled in the art that alert triggers may be specified for all information categories. For example, users may choose to receive weather information for a particular location and scores for a particular game as alerts.

30 Referring now to FIG. 8A, a schematic view of a preferred embodiment of an interactive web page for specifying the messages information category is described. Interactive web page 65 enables users to specify a unified messaging system. Unified messaging

-21-

system 66 allows users to specify e-mail addresses, phone, fax, and page numbers to be used as default returning and forwarding points of contact by the IR system. Users also may specify different points of
5 contact for handling alert triggers issued by the IR system. Unified messaging system 66 contains message action window 67 to enable users to specify actions to be performed when certain messages are received. Message action window 67 contains two fields, message
10 field 67a and action field 67b. Message field 67a allows users to specify the message conditions under which an action may be executed. Those conditions are typically the arrival of a message from a specific sender. The action performed on a message condition in
15 message field 67a is specified in action field 67b.

Two types of actions are possible, a forward action, to forward the messages specified in message field 67a to a given point of contact, such as an e-mail address, fax, phone number, or voice mail, and an
20 alert action, to cause the IR system to alert the user when the message specified in message field 67a is received. For example, a user may want to be alerted any time he or she receives an e-mail from a family member, or it is desired to forward all e-mail messages
25 containing business information to a special file folder. Interactive web page 65 also contains control buttons 68, 69, 70, and 71, to allow users to delete, add, edit, or create a new message/action pair in message action window 67. It will be understood by
30 those skilled in the art that different control buttons may be included in the web site.

Referring to FIG. 8B, an example message window displayed on interactive web page 65 for specifying the messages information category is

-22-

described. Message window 72 is displayed on interactive web page 65 to present to the user the current list of messages sent to the points of contact specified in unified messaging system 66. Message
5 window 72 displays message list 73 according to message status, message type, message sender, message subject, and message date. The message status is either *new*, to indicate a new incoming message, *read*, to indicate that the message has already been read by the user, or
10 *forwarded*, to indicate that the message has been forwarded to another user. The message type is either an e-mail, a voice mail, or a fax notification. Message window 72 also contains control buttons 74, 75, 76, 77, and 78, to allow users to perform various
15 actions on the messages presented in message list 73, including deleting a message from the list (74), replying to a message from the list (75), forwarding a message from the list to another user (76), creating a new message list folder (77), and specifying an action
20 to be performed any time a given message from the message list is received (78). It will be understood by those skilled in the art that different control buttons may be included in message window 72.

Referring now to FIG. 9, an example text
25 transcript of user access to an illustrative embodiment of the present invention in which the MCD is a telephone and the IR system is an IVR system is described. Text transcript 79 contains the text translation of voice or telephone key selection
30 commands issued by the user as well as the text translation of the voice information sent by the IR server to the user during a user's phone call to the IR system. Upon dialing the phone number corresponding to the IR system, the user receives alert voice

-23-

notification 80 from the IR server relating to the user
all the alerts specified by the user when interacting
with the web page interface. After a brief pause
following alert notification 80, the IR server presents
5 the user menu of options 81 to prompt the user for
access to the information categories. When the user
selects an information category option by pressing the
corresponding telephone keypad or by saying the number
corresponding to the selected information category, the
10 IR server executes the script corresponding to the
information category, fetches the information from the
Internet, and translates the information to the user
through information voice notification 82.

A brief pause follows information voice
15 notification 82, and the user then hears menu 81 again
to select further information categories. The user
selects the messages information category, and listens
to message notification 83 from the server. Selecting
the messages information category again after listening
20 to message notification 83 triggers the IR server to
read the messages in message notification 84 to the
user. At any point during the phone call the user may
choose to hangup, or to return to menu of options 81 to
access additional information categories.

25 Although particular embodiments of the
present invention have been described above in detail,
it will be understood that this description is merely
for purposes of illustration. Specific features of the
invention are shown in some drawings and not in others,
30 and this is for convenience only and any feature may be
combined with another in accordance with the invention.
Steps of the described processes may be reordered or
combined, and other steps may be included. Further
variations will be apparent to one skilled in the art

-24-

in light of this disclosure and are intended to fall within the scope of the appended claims.

-25-

What Is Claimed Is:

1. Apparatus for providing a user with access to personalized Internet information comprising:
a server comprising one or more computers and programmed to communicate with a multiplicity of client computers;

a personalization routine executable on the server, the personalization routine adapted to enable the user to personalize Internet information to be accessed; and

an interactive response routine executable on the server, the interactive response routine adapted to provide the user with access to personalized Internet information using a mobile communications device.

2. The apparatus of claim 1 wherein each one of the multiplicity of client computers has a memory that contains web browser software routines.

3. The apparatus of claim 2 wherein the personalization routine comprises:

web server software routines; and
a plurality of software routines for accessing personalized information from the Internet.

4. The apparatus of claim 2 wherein the mobile communications device is a telephone, the interactive response system is an interactive voice response system, the interactive response routine is an interactive voice response routine, the interactive voice response routine comprising:

a plurality of software routines for translating text into speech; and

-26-

a plurality of software routines for communication with a telephone user.

5. The apparatus of claim 3, wherein the plurality of software routines for accessing personalized information from the Internet comprises a plurality of sets of scripts, each one of the sets of scripts associated with a user and an information category and containing one or more scripts for accessing information from the Internet.

6. The apparatus of claim 5, wherein the sets of scripts are stored in a personalized information database in the server.

7. The apparatus of claim 5, wherein the information categories comprise one or more categories selected from a group consisting of: a messages category; a quotes category; a news category; a weather category; a sports category; a favorites category; an address book category; a calendar category; and a downloads category.

8. The apparatus of claim 5, wherein the scripts contain a series of steps to be executed by the server to extract one or more items of information from the Internet.

9. The apparatus of claim 8, wherein the series of steps comprise steps for: accessing a web site from a web server; providing user account information to access information displayed in the web site; extracting the items of information specified in the script from the web site; and

-27-

determining whether the items of information extracted from the web site contain information alerts.

10. The apparatus of claim 4, wherein the software routines for communication with a telephone user comprise routines for:

translating a key pressed by the telephone user into a command for executing a script for accessing personalized information from the Internet; translating a voice prompt from the telephone user into a command for executing a script for accessing personalized information from the Internet; and providing voice prompts that supply information to the user of the telephone.

11. A method for providing access to personalized Internet information via a mobile communications device, the method comprising:

providing a web page interface to allow users to personalize Internet information to be accessed; and at any later time, accessing an interactive response system to obtain personalized Internet information using the mobile communications device.

12. The method of claim 11, wherein providing a web page interface comprises providing a web page interface that enables an user to create an user account and prompts the user for account information.

13. The method of claim 12, wherein providing a web page interface comprises providing a web page interface that prompts the user for one or more of: a connection address to be used when

-28-

accessing the interactive response system; a password for accessing the web page interface in a secure manner; address information; and selection of a service access plan with associated billing options.

14. The method of claim 12, wherein providing a web page interface comprises providing a web page interface that prompts the user for one of: an account phone number to be used when accessing the interactive response system via a mobile communications device or an account password to be used when accessing the web page interface.

15. The method of claim 11, wherein providing a web page interface comprises providing a web page interface that enables the user to select links to web pages for personalizing Internet information for a plurality of information categories.

16. The method of claim 15, wherein providing a web page interface that enables the user to select links to web pages for a plurality of information categories comprises providing a web page that enables the user to select links to one or more of: a messages category; a quotes category; a news category; a weather category; a sports category; a favorites category; an address book category; a calendar category; and a downloads category.

17. The method of claim 15, wherein providing a web page interface that enables the user to select links to web pages for a plurality of information categories comprises providing a web page that enables the user to select links to one or more

-29-

of: a messages web page; a quotes web page; a news web page; a weather web page; a sports web page; a favorites web page; an address web page; a calendar web page; and a downloads web page.

18. The method of claim 17, wherein providing a web page that enables the user to select a link to a messages web page further comprises prompting the user for one or more of: a default phone number for accessing the user's voice mail; a default e-mail address for returning and forwarding e-mail messages for the user; a default fax number; an alert phone number for accessing the user's voice mail to notify the user of an information alert; an alert e-mail address for notifying the user of an information alert by e-mail; and an alert fax number for sending an alert notification fax to the user.

19. The method of claim 18, further comprising, upon the user's accessing the interactive response system, delivering any pending information alerts to the user.

20. The method of claim 11, further comprising, upon the user's accessing the interactive response systems, displaying a message window that displays messages received by the user.

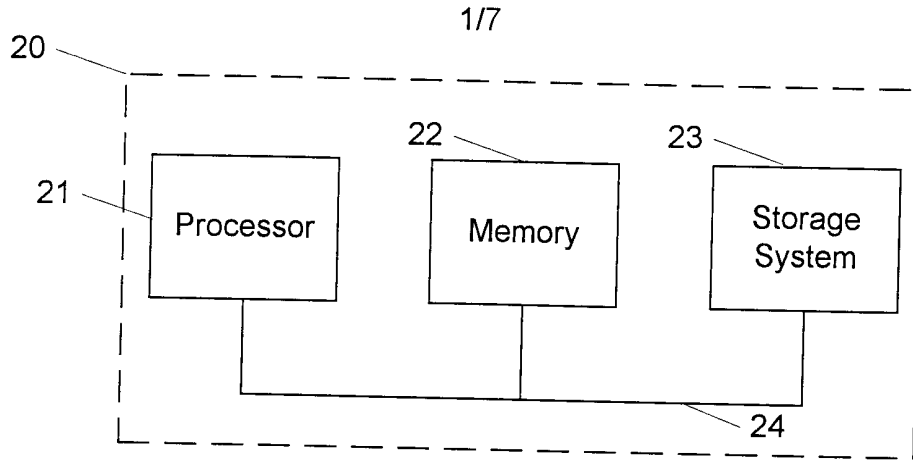

FIG. 1

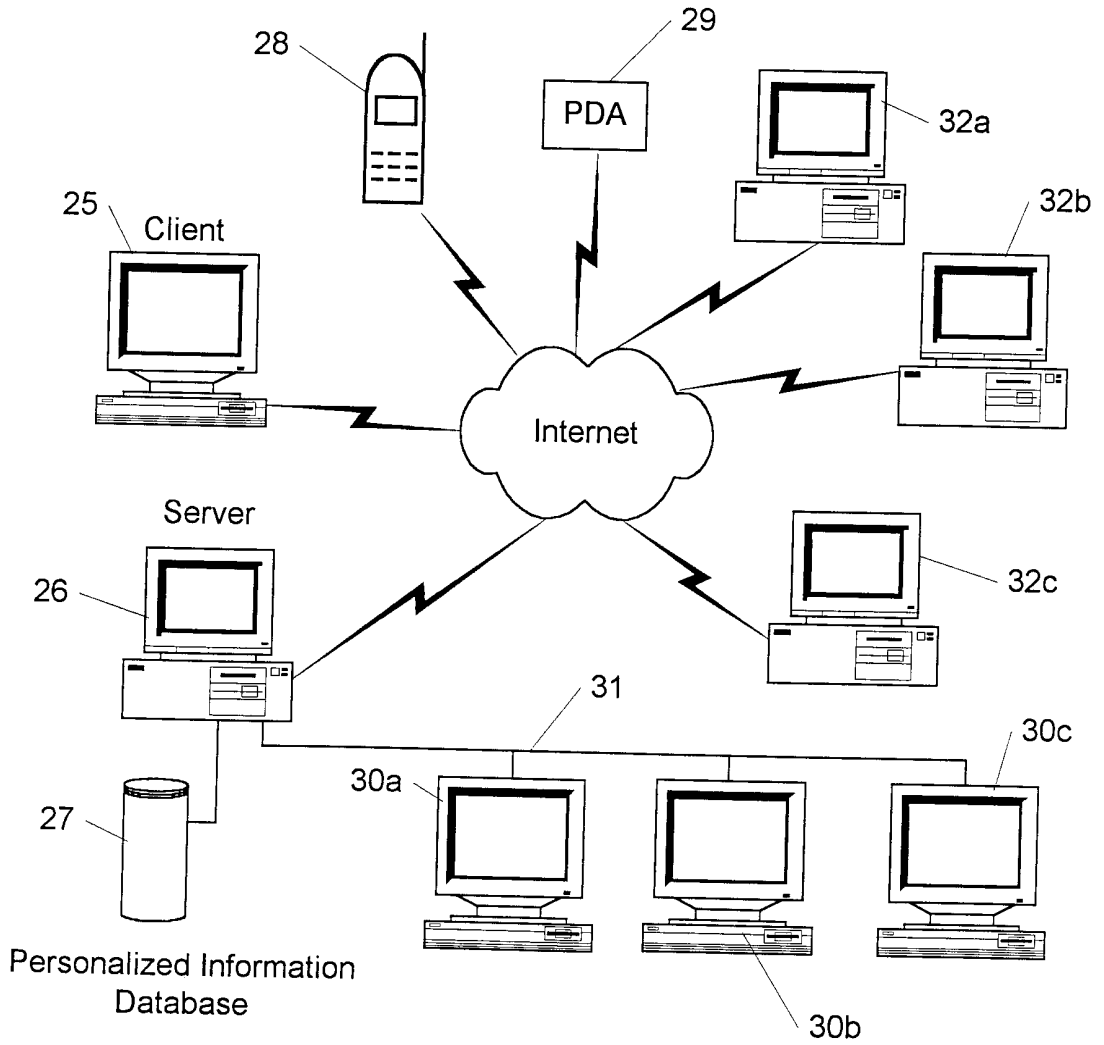

FIG. 2

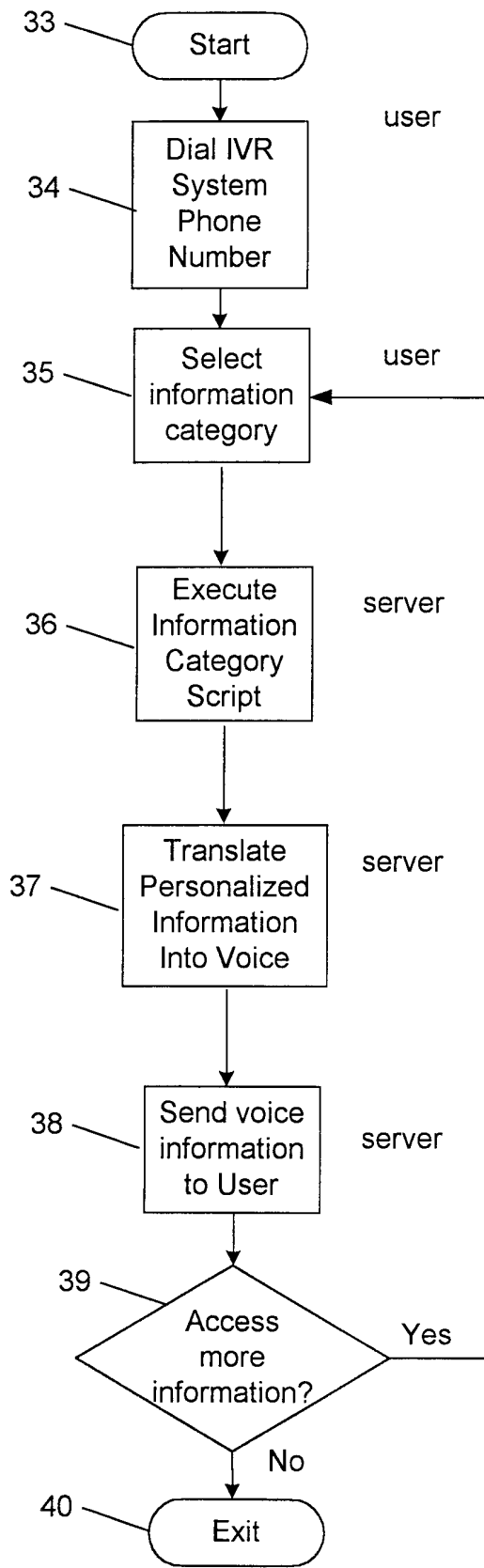

FIG. 3

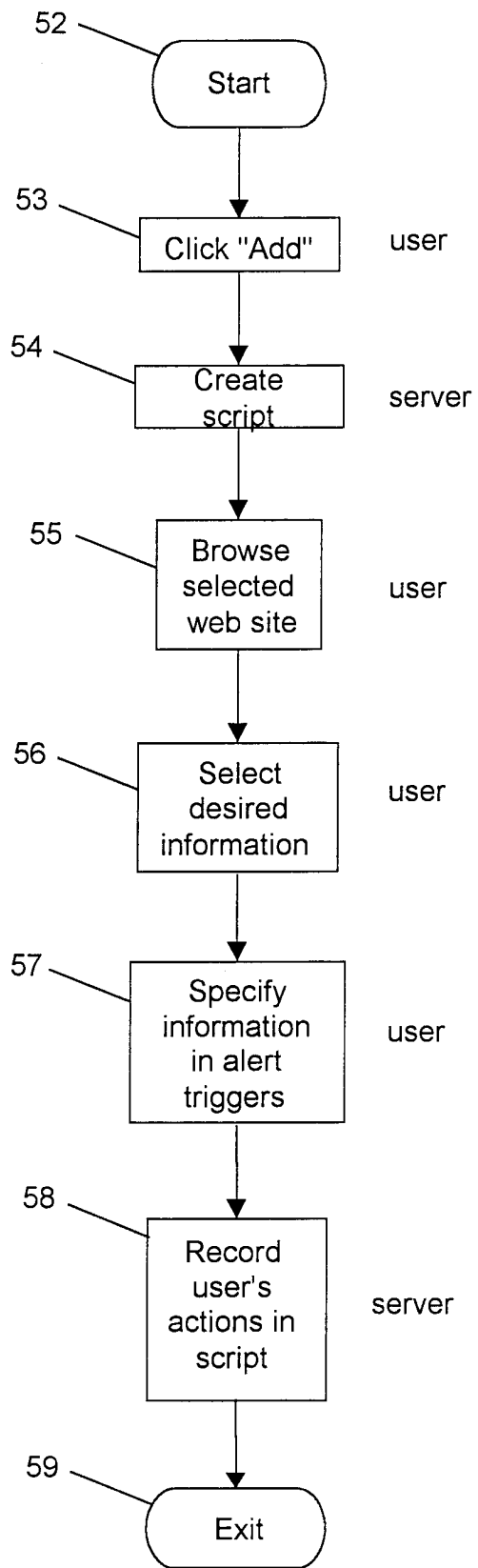

FIG. 7A

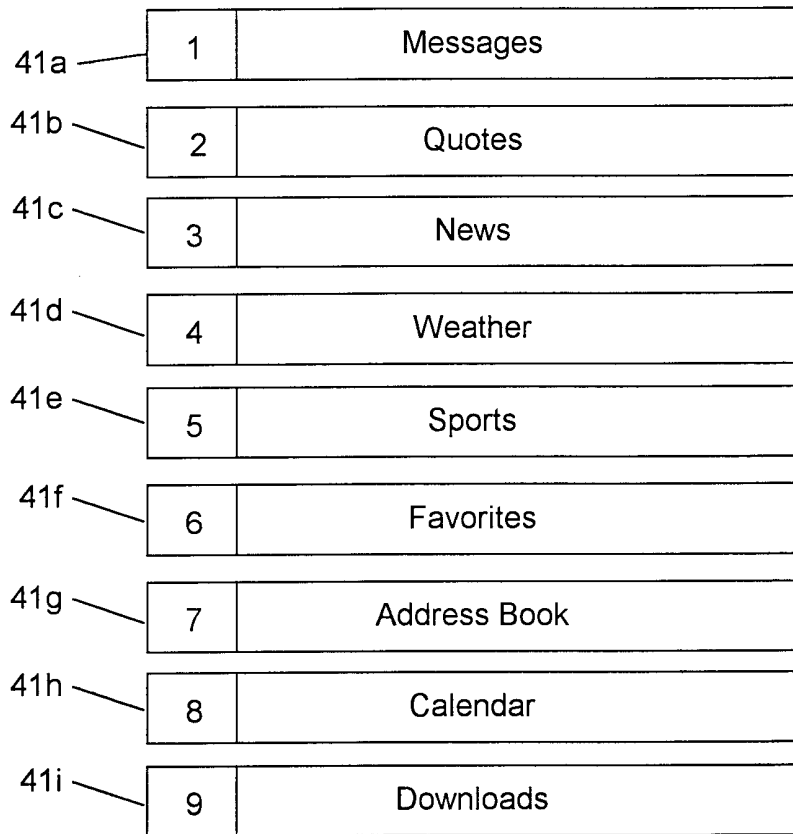

FIG. 4

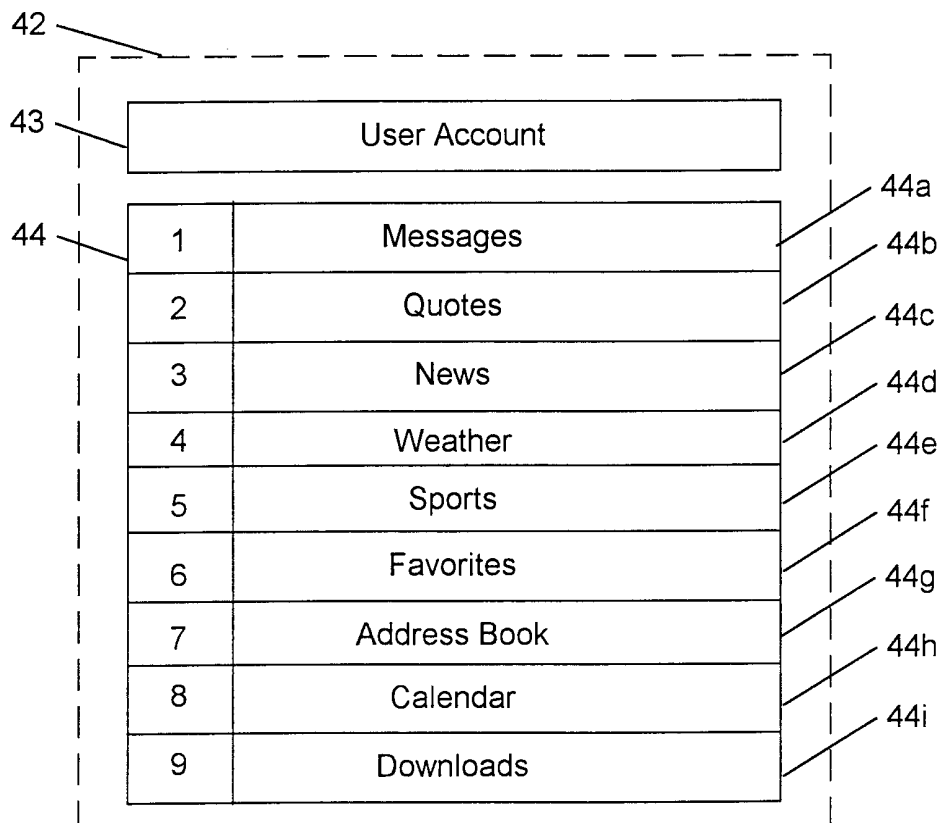

FIG. 5

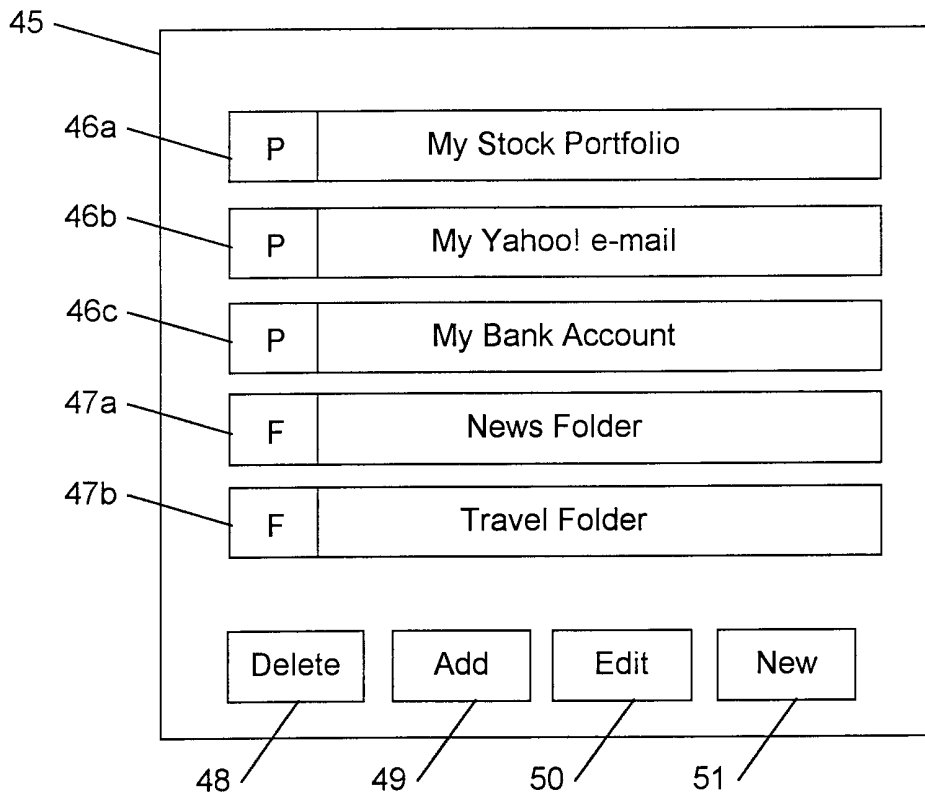
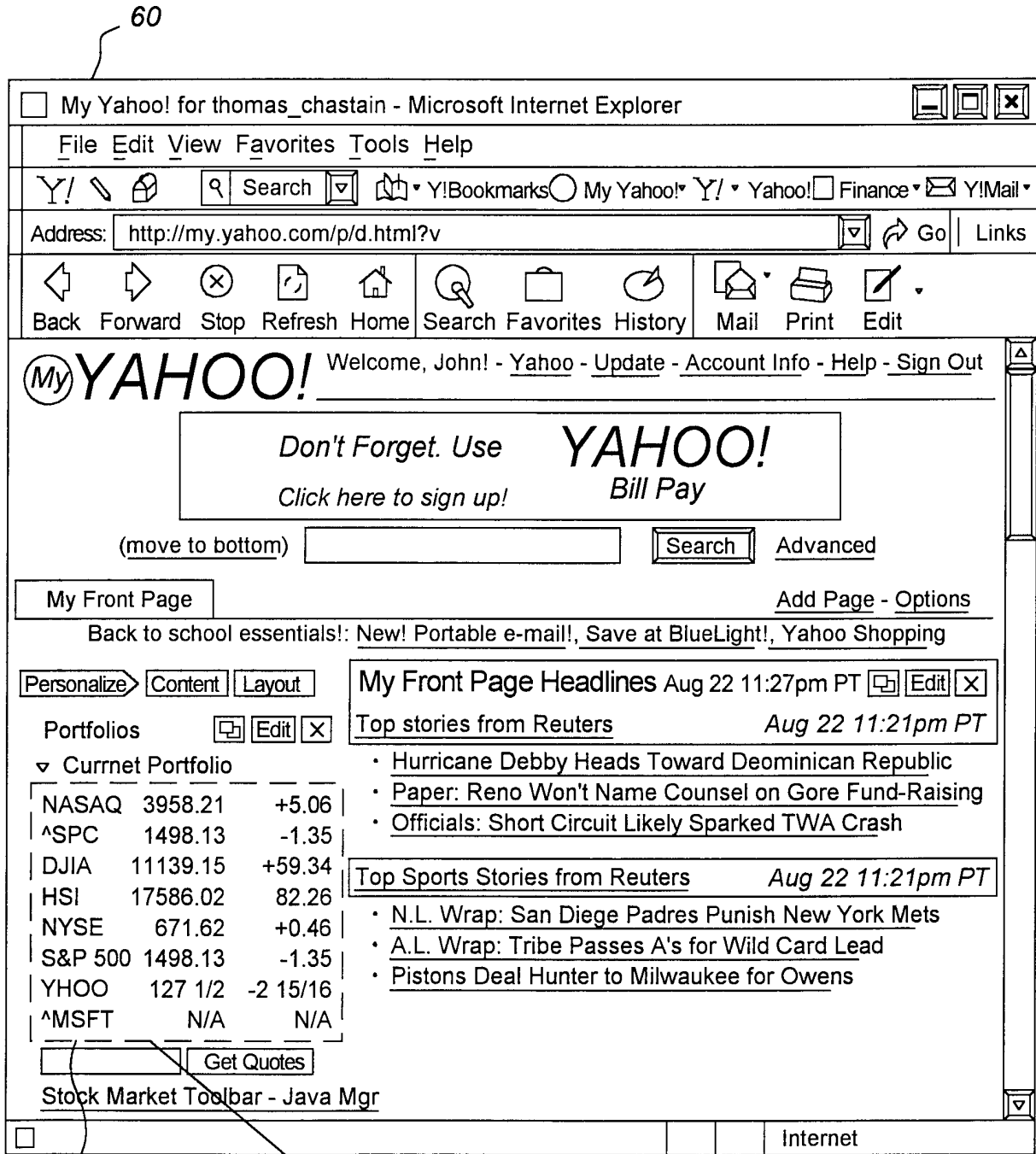

FIG. 6



61

62

Alert for YHOO above 150 by phone

63

64

FIG. 7B

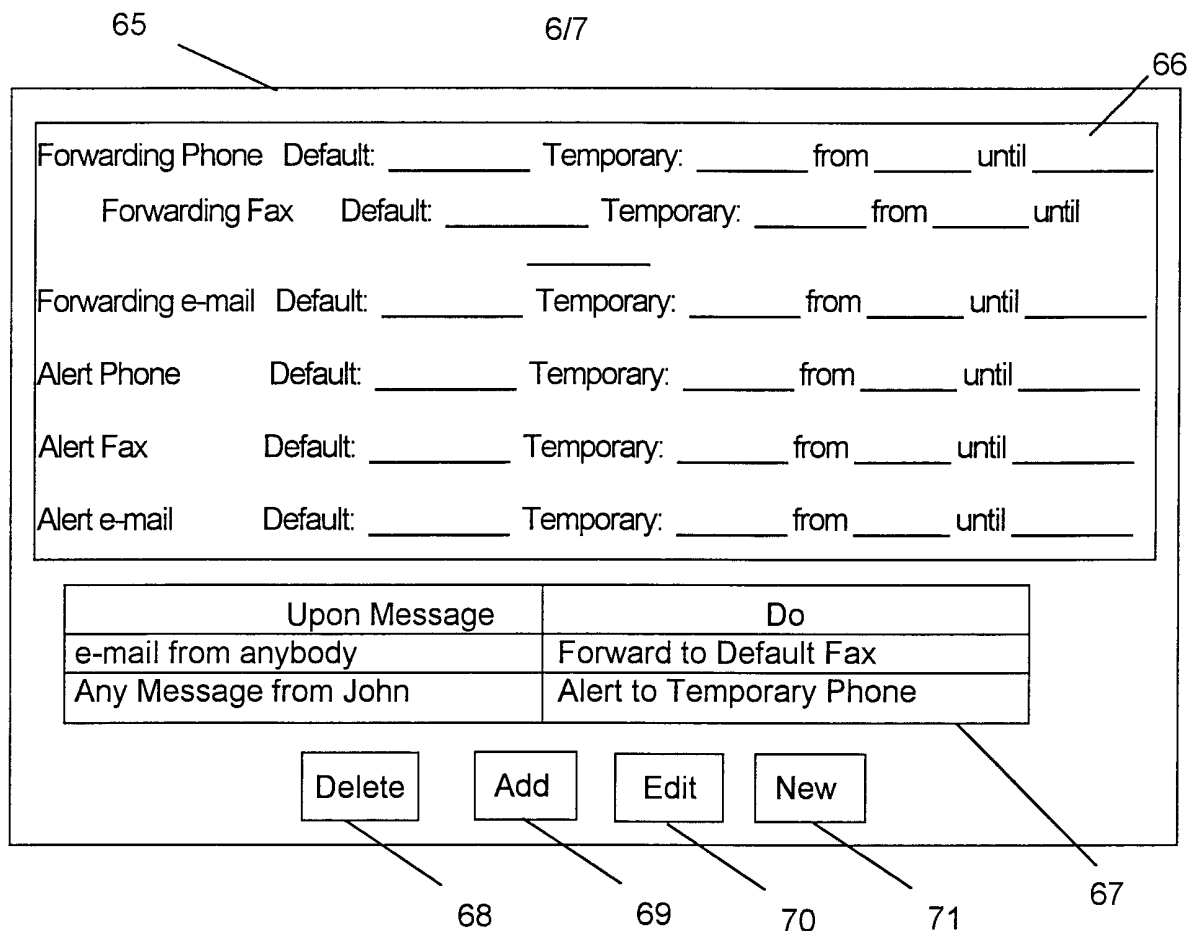

FIG. 8A

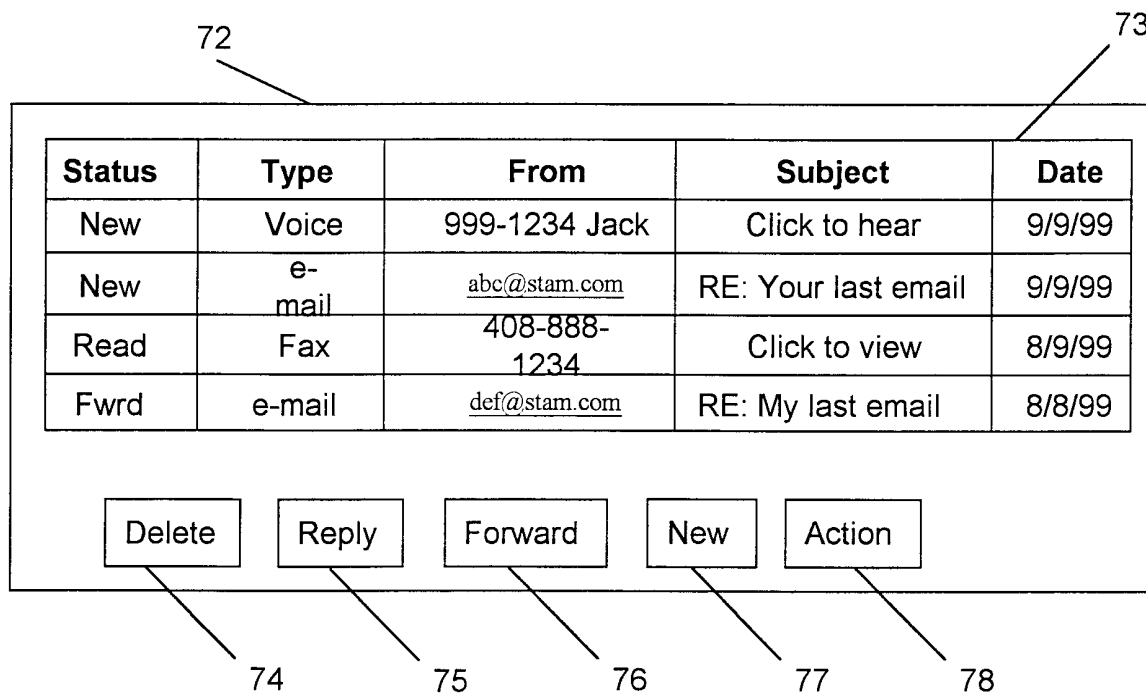

FIG. 8B

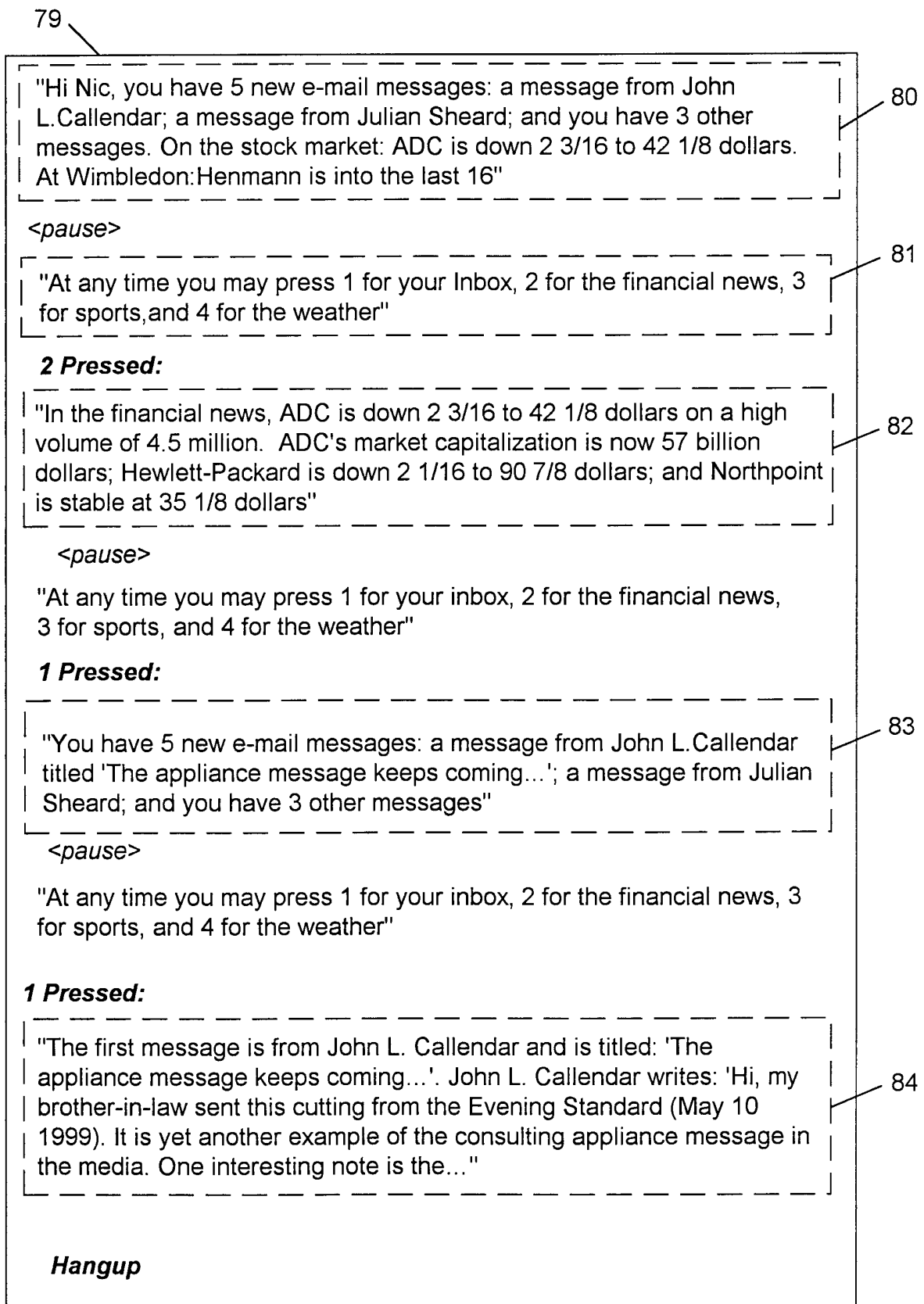

FIG.

9

INTERNATIONAL SEARCH REPORT

International application No.
PCT/US00/25396

A. CLASSIFICATION OF SUBJECT MATTER

IPC(7) : GO6F 15/16
US CL : 709/217, 218, 219, 220, 221; 707/10,101,102,104
According to International Patent Classification (IPC) or to both national classification and IPC

B. FIELDS SEARCHED

Minimum documentation searched (classification system followed by classification symbols)
U.S. : 709/217, 218, 219, 220, 221; 707/10,101,102,104

Documentation searched other than minimum documentation to the extent that such documents are included in the fields searched

Electronic data base consulted during the international search (name of data base and, where practicable, search terms used)
USPT.JPAB.EPAB.PWPI.TDBD

C. DOCUMENTS CONSIDERED TO BE RELEVANT

Category*	Citation of document, with indication, where appropriate, of the relevant passages	Relevant to claim No.
Y,P	US 6,065,120 A (LAURSEN et al) 16 May 2000, col. 13 line 10 et seq.	1-20
Y,P	US 6,031,904 A (ANN et al) 29 February 2000, col. 5 line 6 et seq.	1-20

Further documents are listed in the continuation of Box C. See patent family annex.

- | | |
|---|--|
| * Special categories of cited documents: | *T* later document published after the international filing date or priority date and not in conflict with the application but cited to understand the principle or theory underlying the invention |
| *A* document defining the general state of the art which is not considered to be of particular relevance | *X* document of particular relevance; the claimed invention cannot be considered novel or cannot be considered to involve an inventive step when the document is taken alone |
| *E* earlier document published on or after the international filing date | *Y* document of particular relevance; the claimed invention cannot be considered to involve an inventive step when the document is combined with one or more other such documents, such combination being obvious to a person skilled in the art |
| *L* document which may throw doubts on priority claim(s) or which is cited to establish the publication date of another citation or other special reason (as specified) | *G* document member of the same patent family |
| *O* document referring to an oral disclosure, use, exhibition or other means | |
| *P* document published prior to the international filing date but later than the priority date claimed | |

Date of the actual completion of the international search
08 NOVEMBER 2000

Date of mailing of the international search report
28 NOV 2000

Name and mailing address of the ISA/US
Commissioner of Patents and Trademarks
Box PCT
Washington, D.C. 20231
Facsimile No. (703) 305-3230

Authorized officer *Peggy Hamed*
MEHMET GECKIL
Telephone No. (703) 305-9676