

(No Model.)

2 Sheets—Sheet 1.

J. CAMPBELL.
SLEEPER FOR CABLE ROADS.

No. 600,060.

Patented Mar. 1, 1898.

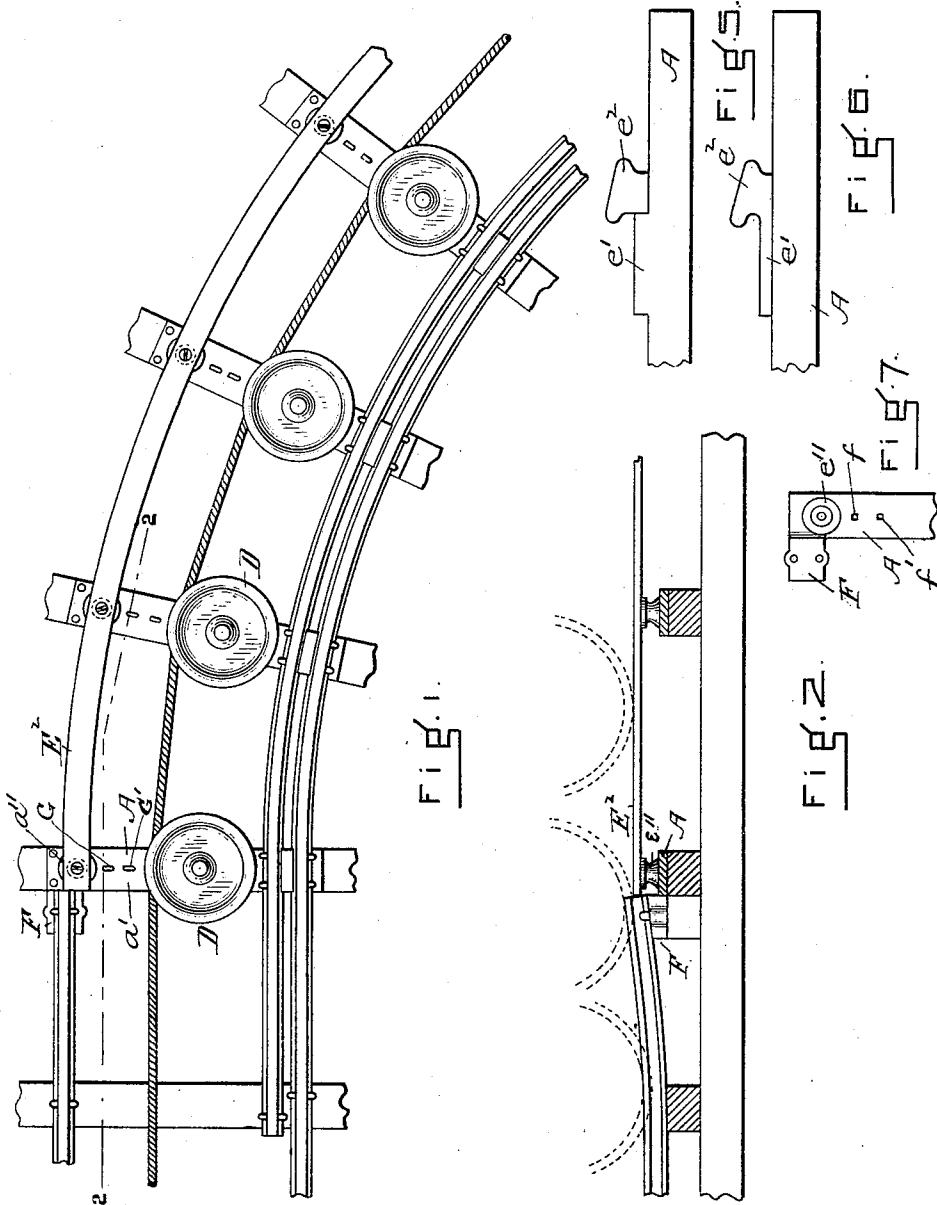

WITNESSES:

J. M. Dolan
L. A. Walsh

INVENTOR
J. Campbell
by his atty
Charles & Raymond

(No Model.)

2 Sheets—Sheet 2.

J. CAMPBELL. SLEEPER FOR CABLE ROADS.

No. 600,060.

Patented Mar. 1, 1898.

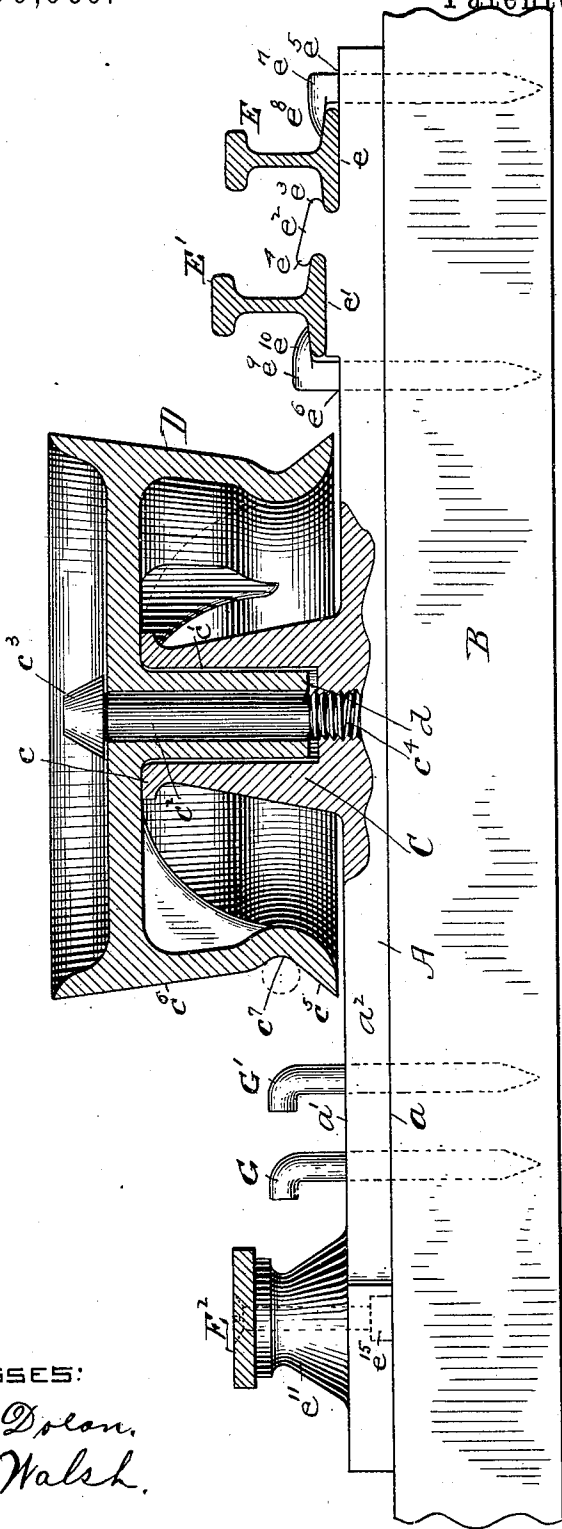

FIG. 3

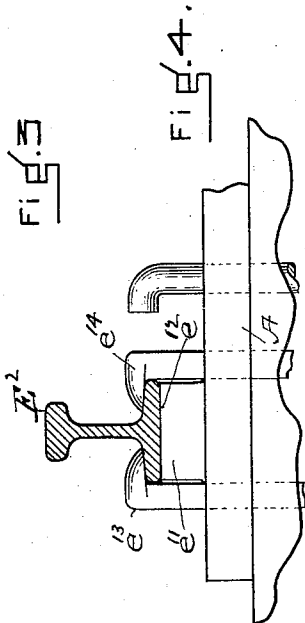

FIG. 4.

WITNESSES:
J. W. Dolan,
L. A. Walsh.

INVENTOR:
J. Campbell
 by his attys—
Clark & Raymond

UNITED STATES PATENT OFFICE.

JEREMIAH CAMPBELL, OF CHELSEA, MASSACHUSETTS.

SLEEPER FOR CABLE-ROADS.

SPECIFICATION forming part of Letters Patent No. 600,060, dated March 1, 1898.

Application filed February 27, 1897. Serial No. 625,238. (No model.)

To all whom it may concern:

Be it known that I, JEREMIAH CAMPBELL, a citizen of the United States, residing at Chelsea, in the county of Suffolk and State of Massachusetts, have invented a new and useful Improvement in Sleepers for Cable-Roads, of which the following is a full, clear, and exact description, reference being had to the accompanying drawings, forming a part of this specification, in explaining its nature.

The invention relates to an improvement in the construction of cable-roads whereby curved sections thereof may be more readily, economically, and strongly constructed.

The improvement is produced or carried into effect by means of a sleeper, of iron, having integral therewith a support for the idler about which the cable runs and which is located between the rails, and also having means for holding at one side of the idler an ordinary T-rail upon which the tread of the wheels upon that side run and a guard-rail which is inside the first-named rail and slightly above it, and also having means upon the other side of the idler for holding another rail, which may be a flat plate-rail designed to receive the flange of a wheel instead of the tread. This iron sleeper is therefore in effect not only a support for the idler and the rails, but a distance-piece which accurately locates the rails in relation to each other and to the idler-support and a chair for properly supporting them and a tie for tying them together.

Figure 1 is a view in plan of a curve in a cable-road containing my invention. Fig. 2 is a view in section upon the dotted line 2 2 of Fig. 1 and in elevation of parts beyond said line, representing in dotted lines the manner in which a wheel runs from its tread to its flange as it leaves a T-rail and runs upon the flat outer rail of the curve. Fig. 3 is a view, principally in side elevation, enlarged, of a sleeper having the features of my invention, the idler-support being broken out to represent the construction and rails being represented in vertical section. Fig. 4 is a detail view to represent the use of an outer T-rail instead of an outer flat rail, as will hereinaf-

ter be described. Figs. 5, 6, and 7 show modifications to which reference is hereinafter made.

A is the sleeper. It is preferably made of cast or malleable iron. It is rectangular in shape, has the flat under surface a , the flat upper surface a' , and the parallel sides a^2 . It is supported by a wooden cross stringer or support B, which preferably extends its full length, and it is secured thereto by the devices employed in fastening the rails to it. It has rising from its surface, preferably nearer the inner end of the sleeper, a support C for the idler D. This support is integral with the sleeper, is preferably conical in shape, and has a flat upper surface c , which furnishes one rest or bearing for the idler. It also has a circular cavity c' , opening from its upper end and extending downwardly any desired distance, which receives the hub d of the idler, the hub not extending to the bottom of the cavity. The hub may be hollow, and the idler may be held to the sleeper by a stud c^2 , the head c^3 of which laps upon its upper surface, and its lower end may be threaded and screw into the threaded hole c^4 in the sleeper or into a nut held in a cavity in the under side of the sleeper.

The idler has an outer surface of usual shape—that is, it has the short inclined section c^5 , the long inclined section c^6 , and the groove c^7 , in which the cable runs. The sleeper also has at its inner end a support e for the rail E and a support e' for the guard-rail E'. The support e' is preferably higher than the support e , and they preferably are integral with the sleeper, although the support e' is not necessarily so, and there is also formed upon the sleeper a portion e^2 , which serves as a distance-piece in locating the rails E E' in relation to each other and also in locating each rail upon the sleeper, and this also serves as a holddown by means of which one edge of the flange of each rail is held down, the flange of the rail E being thus held by the overlapping extension e^3 of said section and a flange of the rail E' being held down by the overlapping extension e^4 of said

section, the section thus holding the inner flange of one rail and the outer flange of the other.

There are also in the sleeper the spike-holes e^5 e^6 , so located as to permit fastening-spikes to be driven in relation to the said rails, so as to cooperate with the distance-piece e^2 and hold-downs e^3 e^4 . The spike-hole e^5 is near the end of the plate and receives the spike e^7 , which cooperates with the holddown e^3 , the spike-hole being a little more than the width of the flange of the rail from the said section e^2 , and so that the head e^8 of the spike when driven will bear upon the outer flange of the rail. (See Fig. 3.) The spike thus not only cooperates with the holddown e^3 and distance-piece or abutment e^2 , but it also serves to lock the sleeper to the wooden stringer, being driven through the hole therein into the stringer or support. (See Fig. 3.) The spike-hole e^6 for receiving the spike e^9 bears the same relation to the holddown e^4 and abutment e^2 in respect to the rail E' , with the exception that its head e^{10} is adapted to extend upon the inner flange of the rail E' . It extends through the spike-hole e^6 into the stringer and cooperates with the spike e^7 in fastening the sleeper to the stringer. It is thus obvious that the section e^2 serves as the line upon which the rails E E' are to be laid, and that to lay them it is simply necessary to bring their flanges below the downholds and to then drive the fastening-spikes. Of course the said plate e^2 and its downholds may be made separate from the sleeper and attached thereto, (see Fig. 5,) or it may be combined with the rest e' and made separate from the rest of the sleeper and attached therewith to the sleeper, and while I consider that such a structure would be within the scope of my invention and have illustrated the last-named form of it in Fig. 6, where the plate is held in position by the inner spike e^{10} , yet I prefer the construction which makes these parts integral with the sleeper. The rail E^2 , which cooperates with the rail E in making the track, may be a T-rail, as represented in Fig. 4, or it may be a flat plate-rail, as represented in Figs. 1 and 3. In this first-named instance it receives the tread of the wheel in the ordinary way. It is preferably mounted upon a raised support e^{11} , preferably integral with the sleeper, the upper surface e^{12} of which is flat, and this serves to elevate the upper surface of the rail in respect to the upper surface of the rail E any suitable distance. The rail is fastened to the sleeper by spikes e^{13} e^{14} . (See Fig. 4.)

When the flat plate-rail is employed, it is of sufficient width to receive the flange of the wheel instead of the tread, and the support e^{11} therefore is made considerably higher than the support for the T-rail, and the flat plate-rail is fastened to the sleeper by a bolt the

head of which is held in a countersunk recess in the plate-rail and the shank of which extends through a hole in the support e^{11} and sleeper and into a nut e^{15} , held in a nut-holding cavity in the sleeper. The bolt has a slot across its head, by means of which it is adapted to be turned from above the plate-rail in screwing it into the nut.

The sleepers which are designed to be placed at the beginning and end of the curve may each have extending laterally from its outer end a support F (see Fig. 7) to receive the end of a T-rail section, and when the flat plate-rail E^2 is used the said support must be sufficiently high to cause the upper surface of the T-rail to be sufficiently above the upper surface of the plate-rail to permit the wheel to run from its tread to its flange as it passes from the T-rail to the plate-rail. (See Fig. 2.) The support for this rail determines its position upon the sleeper and in relation to the rail E . The sleeper is provided with holes f f' for receiving the shanks of the pins G G' . The upper ends of these pins are bent outwardly and their shanks extend through said holes into the stringer or support B , and they serve to assist in fastening the sleeper to the stringer and also as holding devices for holding a cable removed from the idler.

It will be seen that in constructing the track about a curve all the elements necessary for supporting the rails, attaching them to the sleepers, tying them together, and locating them in relation to each other are fixed or determined in advance and what has before been a relatively slow and indefinite construction is very rapidly and readily done.

While an ordinary T-rail may be substituted for the outer curved flat rail, I prefer the latter construction, as it provides means by which the wheel may run on its flange and thereby reduces its slipping action and friction in rounding a curve.

Having thus fully described my invention, I claim and desire to secure by Letters Patent of the United States—

1. The metal sleeper A having the support e^{11} and a hole extending through the same, with the flat rail E^2 and a bolt for fastening the flat plate to said support, and which passes through said support and screws into the nut e^{15} held by the sleeper, the head of said bolt being contained in a countersunk recess in said rail-plate.

2. The combination of a number of metal sleepers A each having the rests e , e' , the section e^2 , the downholds e^3 , e^4 , the spike-holes e^5 , e^6 , the idler-support C , the raised rail-support e^{11} arranged upon different radii with the curved rails E , E' , E^2 , the rails E , E' engaging the section e^2 and downholds e^3 , e^4 as described, the spikes e^7 , e^{10} and the idlers D .

3. The metal sleeper having the integral idler-support C arranged midway its length,

and the idler D mounted thereon to turn upon a vertical axis, as and for the purposes described.

4. A metal sleeper having an integral idler-support C provided with an upper bearing *c* and a central cavity *C'*, with the idler D mounted upon said upper bearing, having a long hub *b* extending into the cavity *c'* and means for attaching the idler to the sleeper.

5. A metal sleeper having the integral rail-

rest *e*, the integral downhold *e*³ and the integral idler-support C having the top bearing *c* in combination with the rail E, the spike *e'*, the idler D mounted upon said idler-support C and rail E², as and for the purposes described.

JEREMIAH CAMPBELL.

Witnesses:

F. F. RAYMOND, 2d,

J. M. DOLAN.