

[54] **SPRAY NOZZLE ORIFICE MEMBER**

[72] Inventor: **Arnold M. Cook, Holden, Mass.**
 [73] Assignee: **Norton Company, Worcester, Mass.**
 [22] Filed: **Dec. 23, 1970**
 [21] Appl. No.: **100,886**

[52] U.S. Cl. **239/599, 239/601**
 [51] Int. Cl. **B05b 1/00**
 [58] Field of Search **239/596, 599, 601**

[56] **References Cited**

UNITED STATES PATENTS

| | | | |
|-----------|--------|---------------|-----------|
| 1,151,258 | 8/1915 | Fischer | 239/596 |
| 3,437,274 | 4/1969 | Apri..... | 239/601 X |

FOREIGN PATENTS OR APPLICATIONS

| | | | |
|---------|--------|--------------------|---------|
| 514,734 | 7/1955 | Canada..... | 239/566 |
| 665,016 | 1/1952 | Great Britain..... | 239/599 |

Primary Examiner—Allen N. Knowles
Assistant Examiner—Edwin D. Grant
Attorney—Allan R. Redrow

[57] **ABSTRACT**

A spray nozzle orifice member which produces a flat fan-shaped spray making it ideally suited for the application of coatings. The orifice is formed by the intersection of a straight bottomed slot on one side and a curved bottom V-shaped groove on the opposite side of said member. The improvement resides in the ease and economy of fabrication of such a spray nozzle member as a function of the groove-slot combination concept.

4 Claims, 6 Drawing Figures

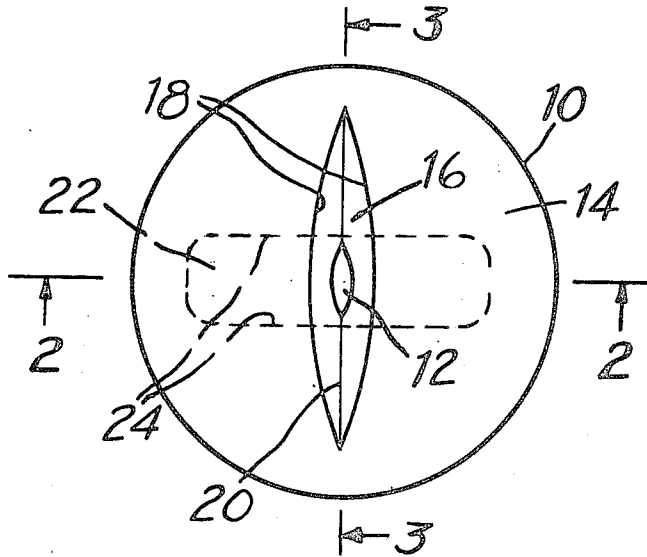

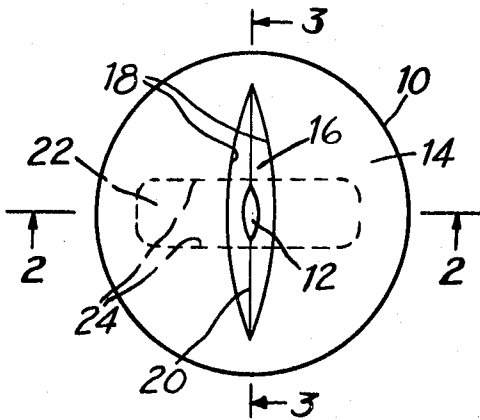

FIG. 1

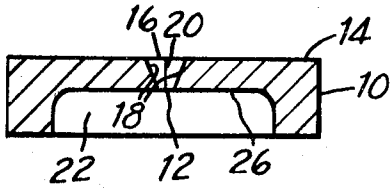

FIG. 2

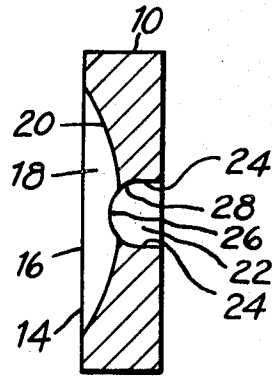

FIG. 3

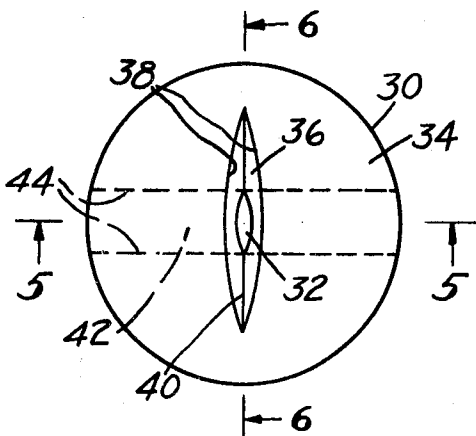

FIG. 4

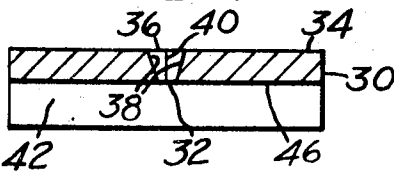

FIG. 5

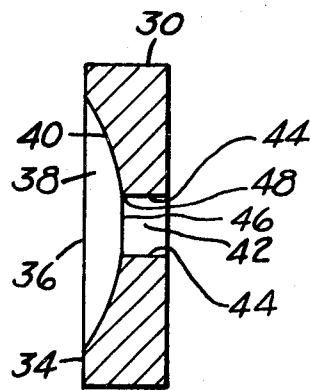

FIG. 6

INVENTOR
ARNOLD M. COOK

BY
Allan R. Redman
ATTORNEY

SPRAY NOZZLE ORIFICE MEMBER

BACKGROUND OF THE INVENTION

The invention relates to spray nozzles which emit a relatively flat fan-shaped spray, making them especially desirable for spraying paint or other types of coatings. More particularly the invention relates to the orifice member of such spray nozzles.

The orifice member of currently used spray nozzles fall into one of two general classes: (1) the rather complexly shaped orifice member typified by those described by Freeman in U.S. Pat. No. 1,813,733; 813,733; Wahlin in U.S. Pat. Nos. 2,621,078, 2,722,458, 2,743,138, and 2,683,627; and Steinen in U.S. Pat. No. 3,045,932; and, (2) the more simple design such as that described by Carroll in U.S. Pat. No. 2,522,928; and Fischer in U.S. Pat. No. 1,151,258.

The geometry of the more complex class of orifice members is such that to insure the proper spray pattern and discharge volume, extremely close tolerance of several interrelated surfaces must be maintained. For example, orifice members such as those described by Wahlin utilize a relatively deep inner cavity of circular cross section, having an accurately defined spherical surface at its bottom. The outer cavity is also generally spherical and must be concentric with the inner spherical surface, and contain therein a V-groove which must intersect the inner and outer spherical surfaces on the centerline of the spherical radius. The depth of the V-groove penetrating the inner surface determines the angle of the spray pattern.

The other class of orifice members, though of less complex geometry still possesses the inherent requirement that the two grooves be located within extremely close tolerance relative to one another. In both the Carroll and Fischer orifice members the two grooves must be accurately machined, or otherwise formed, relative to each other with respect to (a) the angle the grooves make with each other in order to produce the proper orifice configuration, (b) the transverse location of one groove to the other as this effects the size of the orifice because of the concavity of the bottoms of said grooves, (c) the angles formed by the walls of the grooves as these effect size and shape of the orifice, and of course, (d) the relative depth of each groove. Only slight deviations in any one of these, results in a significant change in the orifice size or configuration.

Applicant's invention is an orifice member, the novel design of which essentially eliminates the extremely close tolerance requirements of the prior art orifice members, thereby facilitating manufacture thereof.

SUMMARY OF THE INVENTION

A simply manufactured spray nozzle orifice member, which emits a flat fan-shaped spray, results from the novel design of the orifice member of the invention. The outer face of the orifice member contains a V-shaped groove having oppositely curved walls and a concavely curved bottom or apex. This groove very much resembles the groove in the outer face of both the Carroll and Fischer nozzle orifice members. The inner face however, contains not a curved bottomed groove but rather a slot cut at approximately 90° to the groove in the outer face, which has essentially straight walls and a straight bottom. The straight bottom of said slot may form an angle with the straight walls, or there may be a radius of curvature where the walls and bottom meet such as would result if the slot was cut with a preformed cutting tool or end mill with a convex cutting surface. It is necessary however, that the longitudinal bottom surface of the slot be essentially straight.

While it is required that the V-shaped groove be so placed on the outer face and be of such a size that it is not overlapped by the cap or nut fastening it to the nozzle body, no such restriction is placed on the slot on the inner face. Said slot may originate and terminate well within the periphery of the orifice member or it may originate and terminate at the periphery i.e., traverse the complete diameter of the orifice member.

The combination of a V-shaped groove having oppositely curved walls and a concavely curved bottom on the outer face of a spray nozzle orifice member, intersecting with a slot having essentially straight walls and a straight bottom to form an elliptically shaped orifice, results in an orifice member that is simple and economic to manufacture. Because the slot on the inner face is comprised of straight walls and a straight bottom the orifice configuration is little affected if the angle of said slot and the V-shaped groove on the outer face is not exactly 90°. Furthermore, the transverse location of slot to groove has no effect on the size or shape of the orifice because the bottom of the slot is straight, in the transverse direction, therefore the shape and size of the orifice remains the same regardless of where the groove intersects the slot. Furthermore still, only the angle of the V-shaped groove need be machined to close tolerances, the slot being a relatively open, straight walled (non V-shaped) depression. Thus the complexity of the manufacturing process of the invention orifice members is reduced to accurately machining the V-shaped groove on the outer face. Controlling the depth of the groove, which in the instant case affects only the size of the orifice and not the configuration thereof, is a simple matter once the requirement of extremely close tolerances between several interrelated surfaces inherent in the prior art orifice members, is eliminated.

BRIEF DESCRIPTION OF THE DRAWING

FIG. 1 is a plan view showing the outer face of the orifice member.

FIG. 2 is a sectional view taken approximately on line 2—2 in FIG. 1.

FIG. 3 is a sectional view taken approximately on line 3—3 in FIG. 1.

FIG. 4 is a plan view of another embodiment of the invention showing the outer face of the orifice member.

FIG. 5 is a sectional view taken approximately on line 5—5 in FIG. 4.

FIG. 6 is a sectional view taken approximately on line 6—6 in FIG. 4.

DESCRIPTION OF THE PREFERRED EMBODIMENTS

FIGS. 1, 2 and 3 illustrate one embodiment of the invention. The orifice member 10 containing the elliptical spray orifice 12, is essentially disc shaped. In the outer face 14 of the orifice member 10 there is a V-shaped groove 16 having oppositely curved walls 18, said groove terminating in a curved bottom or apex 20. The inner surface of the orifice member 10 contains therein a slot 22, having essentially straight sidewalls 24 and straight bottom 26. There is a radius of curvature 28 where the straight bottom 26 meets the walls 24 of the slot 22. This particular configuration of slot 22 will result if the slot is cut with an end mill having a convex cutting surface. If the end mill has a flat cutting surface, the slot will not have the radius 28, but will have essentially a right angle meeting of bottom and walls. The slot 22, in this particular embodiment, is contained well within the periphery of the inner face of the orifice member 10.

FIGS. 4, 5, and 6 exemplify a second embodiment of the invention. Here the disc-shaped orifice member contains an elliptical spray orifice 32, located in the approximate center thereof. In the outer face 34 of the orifice member 30 there is a V-shaped groove 36 having oppositely curved walls 38, said groove terminating in a curved bottom 40. The inner surface of the orifice member 30 contains therein a slot 42, having essentially straight sidewalls 44 and straight bottom 46. Here the straight bottom 46 and straight walls 44 meet to form an approximate right angle 48. The configuration of the slot 42 in this embodiment results from cutting said slot with an end mill having a flat cutting surface. Alternatively, an end mill having a convex cutting surface may be used which would result in a straight bottomed, straight walled slot with a radius of curvature such as shown in FIG. 3. In the orifice member 30 of FIGS. 4—6, the slot 42 traverses the entire diameter of the disc-

shaped orifice member 30. The same angular straight bottomed, straight walled slot may be cut so as to be contained well in from the periphery of disc-shaped orifice member 30, in a similar placement as the slot 22 in FIGS. 1-3.

Either the slot or the V-shaped groove may be cut into a blank disc initially, followed by cutting of the other depression. It is preferred however, to cut the more complexly shaped groove first, then to form the slot to the proper predetermined depth intersecting the groove to form the elliptically shaped orifice of the desired size. The techniques and tools used to form the orifice members of the present invention are well known to the skilled machinist. Furthermore, the invention orifice members could be molded into a finished product, although molding does not lend itself to extreme accuracy of orifice size, if this be critical to a given spraying application.

The present orifice members can be fabricated from any machineable or moldable material. The prime consideration in material selection is its wear resistance to the substance to be sprayed and the ease with which the material can be formed. Among those materials which may be used are tungsten carbide, boron carbide, aluminum oxide, bauxite, steel, iron, bronze, copper, zinc, thermoset polymers like phenolaldehydes, epoxies, unsaturated polyesters, and moldable thermoplastic polymers, like polytetrafluorethylene, polyethylene and polypropylene. Materials like boron carbide and tungsten carbide are, for most spraying applications, the most wear resistant. On the other hand orifice members fabricated from plastics may be advantageous from a chemical resistance point of view.

The foregoing illustrations of the invention are not to be construed as limiting. The essence of the present invention is the combination, in a spray orifice member, of a V-shaped

groove having a concavely curved bottom intersecting a straight walled, straight bottomed slot to form an elliptical spray orifice, said combination resulting in an easily manufactured orifice member which emits a flat fan shaped spray. Additional embodiments of the present orifice member may be apparent to those skilled in the art; said possible additional embodiments are intended to be included within the scope of the appended claims.

What is claimed is:

1. A spray nozzle orifice member, adaptable to be joined with a nozzle body and which produces a flat fan-shaped spray, said nozzle orifice member having an inner and outer face, said outer face containing therein a V-shaped groove having oppositely curved walls and a concavely curved bottom, said inner face containing therein a slot having essentially straight walls and a straight bottom, said groove and said slot being oriented at approximately right angles to each other and intersecting so as to form an elliptical orifice.

2. The spray nozzle orifice member of claim 1 wherein said straight bottom of said slot has a radius of curvature which meets said essentially straight walls of said slot.

3. The spray nozzle orifice member of claim 1 wherein said straight bottom of said slot meets said essentially straight sidewalls at an angle of approximately 90°.

4. The spray nozzle orifice member of claim 1 wherein said orifice member is disc shaped and fabricated of a material selected from the group consisting of tungsten carbide, boron carbide, aluminum oxide, bauxite, steel, iron, bronze, copper, zinc, phenol-aldehyde polymer, epoxy resin, unsaturated polyester resin, polytetrafluoroethylene, polyethylene, and polypropylene.

* * * * *

35

40

45

50

55

60

65

70

75