



Dec. 6, 1960

F. P. CROTSEY ET AL

2,962,872

REFRIGERATOR CONSTRUCTION AND CONTROLS

Filed Jan. 13, 1958

5 Sheets-Sheet 2

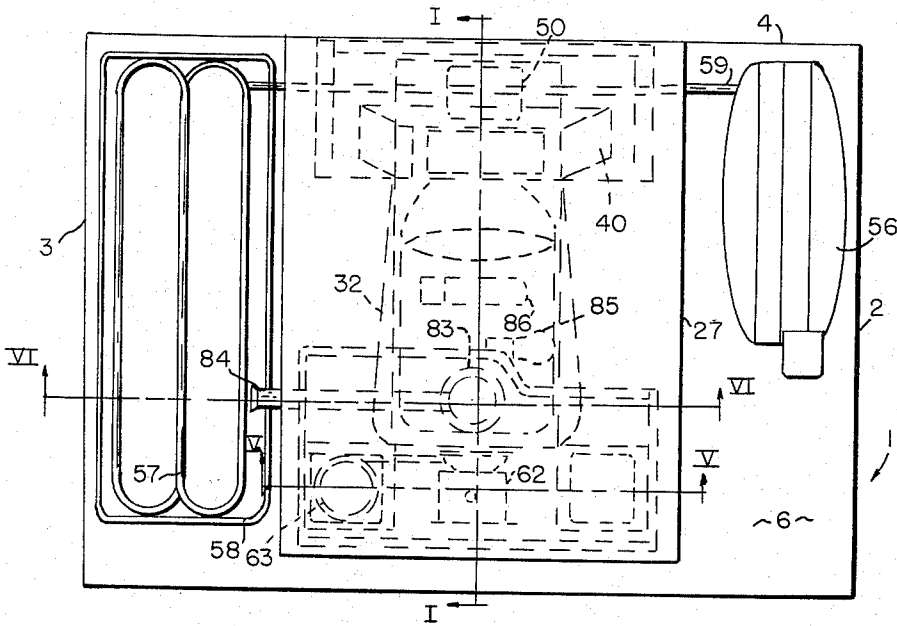

**Fig. II**

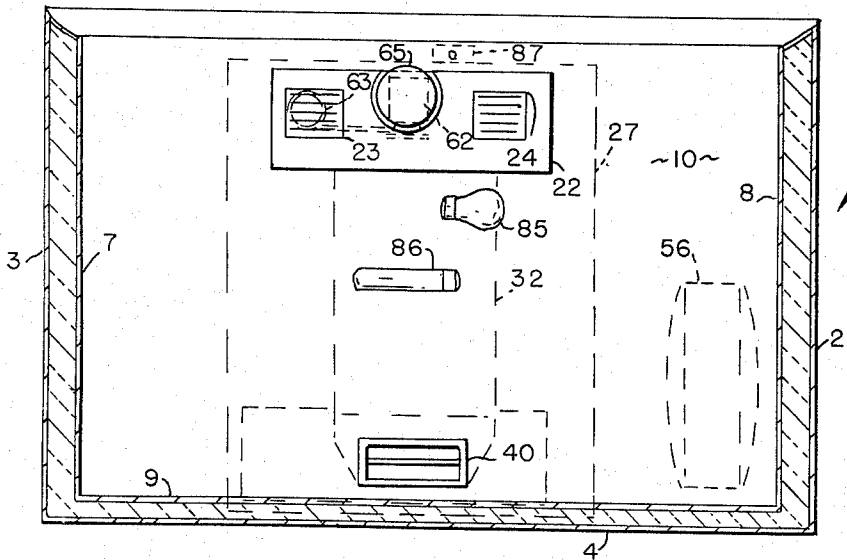

**Fig. III**

INVENTORS.  
FRANK P. CROTSEY  
HOWARD J. TENNISWOOD  
BY

*Marshall, Marshall & Jewsting*  
ATTORNEYS

Dec. 6, 1960

F. P. CROTSEY ET AL

2,962,872

REFRIGERATOR CONSTRUCTION AND CONTROLS

Filed Jan. 13, 1958

5 Sheets-Sheet 3

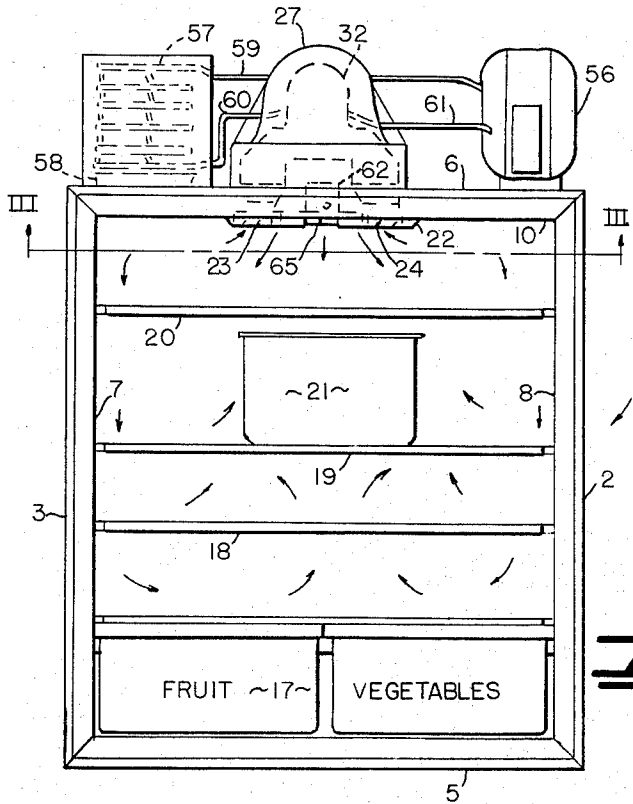

**Fig. IV**

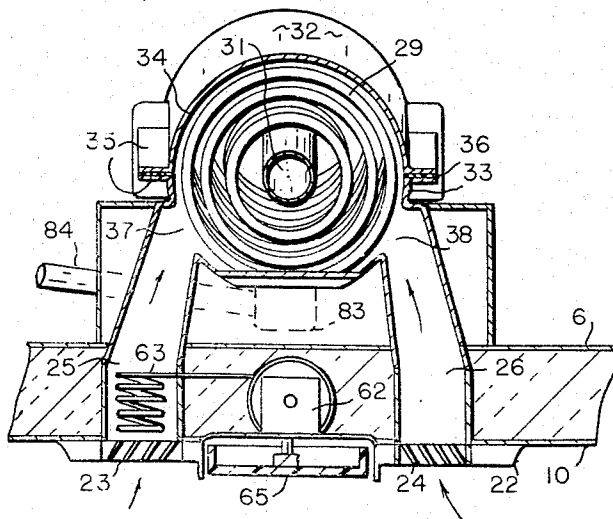

**Fig. V**

INVENTORS.  
FRANK P. CROTSEY  
HOWARD J. TENNISWOOD

BY

*Marshall, Marshall & Yeasting*  
ATTORNEYS

Dec. 6, 1960

F. P. CROTSEY ET AL

2,962,872

REFRIGERATOR CONSTRUCTION AND CONTROLS

Filed Jan. 13, 1958

5 Sheets-Sheet 4

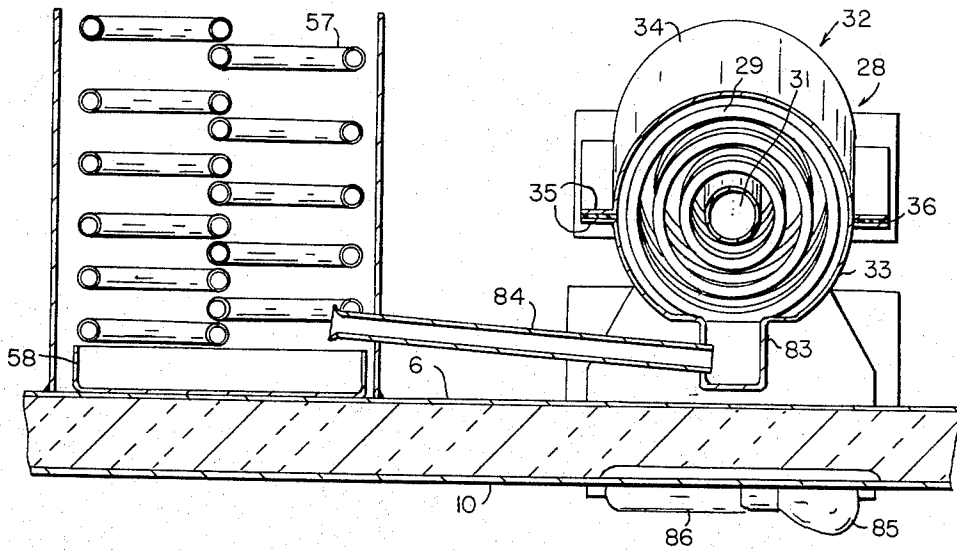

Fig. VI

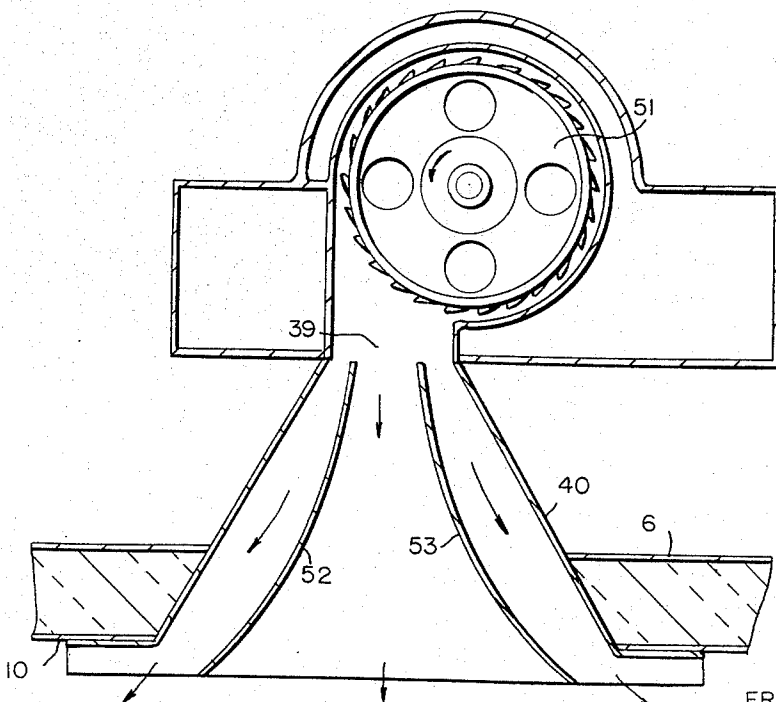

Fig. VII

INVENTORS.

FRANK P. CROTSEY

HOWARD J. TENNISWOOD

BY

*Marshall, Marshall & Geasting*  
ATTORNEYS

Dec. 6, 1960

F. P. CROTSEY ET AL

2,962,872

REFRIGERATOR CONSTRUCTION AND CONTROLS

Filed Jan. 13, 1958

5 Sheets-Sheet 5

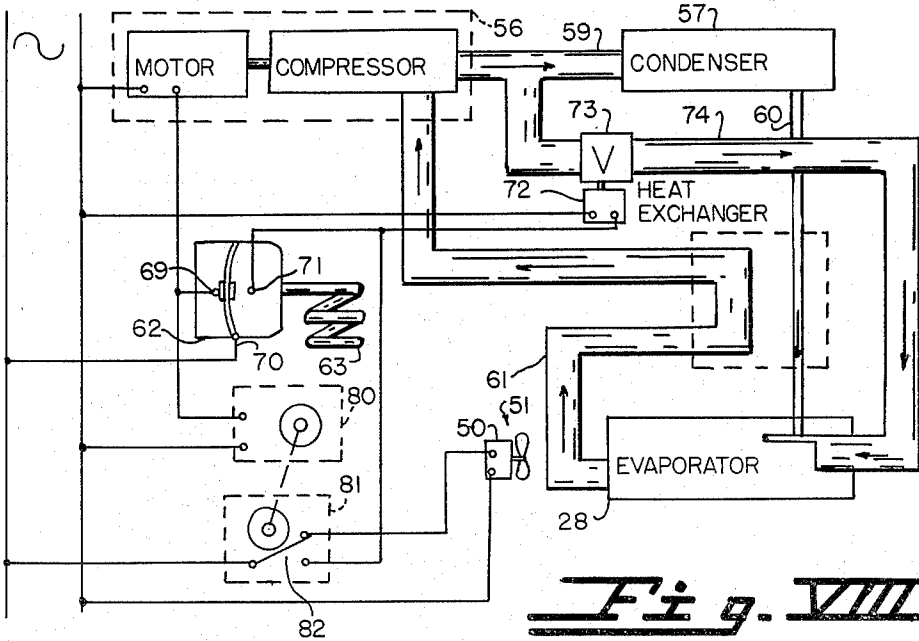

**Fig. VIII**

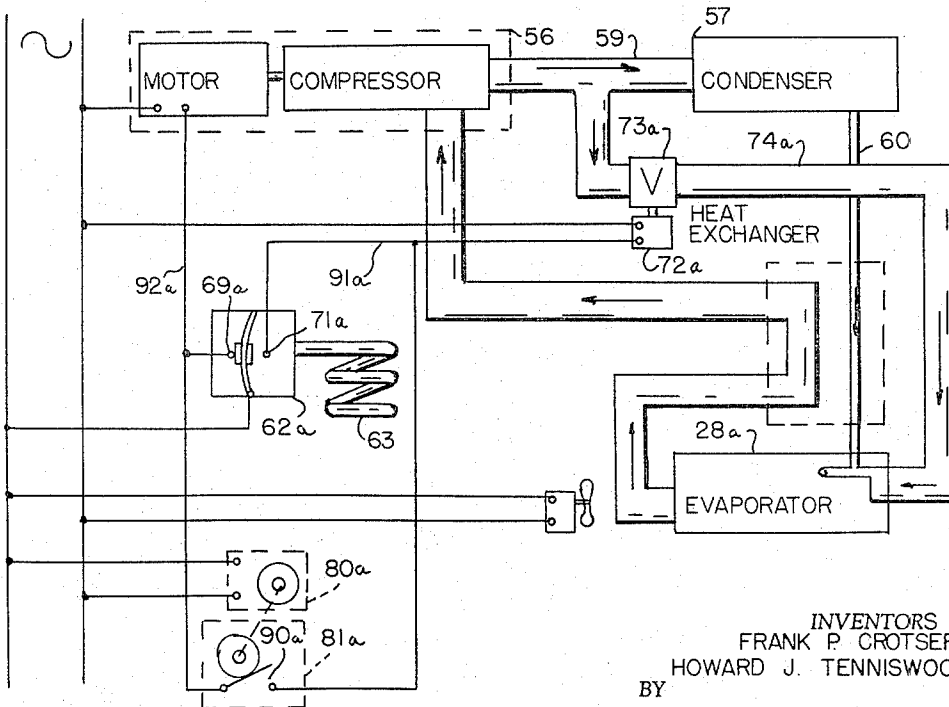

**Fig. IX**

INVENTORS  
FRANK P. CROTSEY  
HOWARD J. TENNISWOOD

BY

*Marshall, Marshall, Yeasting*  
ATTORNEYS

1

2,962,872

## REFRIGERATOR CONSTRUCTION AND CONTROLS

Frank P. Crotser and Howard J. Tenniswood, Adrian, Mich., assigns to Revco, Inc., Deerfield, Mich., a corporation of Michigan

Filed Jan. 13, 1958, Ser. No. 708,705

12 Claims. (Cl. 62-155)

This invention relates to refrigerators of the type in which a fluid refrigerant having a low boiling point is compressed while in the gaseous phase and forced into a condenser where it cools under pressure and thus is transformed into the liquid phase, the refrigerant then being reevaporated and absorbing heat as it returns to the gaseous phase, in which it is again compressed.

A refrigerator of the type to which this invention relates has a pump, commonly called a compressor, for compressing the refrigerant, a motor for operating the compressor, a heat radiating coil, commonly called a condenser, into which the refrigerant is compressed by the pump, a restricted passage through which the condensed refrigerant escapes from the condenser into a heat absorbing coil, commonly called an evaporator, where the refrigerant reverts to the gaseous phase, and a return conduit through which the refrigerant is evacuated by the pump, being recompressed, recondensed, and reevaporated through repeated cycles.

The evaporator, within which the refrigerant absorbs heat that is carried away when the refrigerant is evacuated from the evaporator, is usually located inside of a thermally insulated cabinet which is arranged to contain food and beverages to be chilled, and sometimes water to be frozen. The motor, the compressor and the condenser, which radiate heat, are located outside the thermally insulated cabinet. Since the chilled space inside the thermally insulated cabinet is precious, it is desirable that it be kept unencumbered by drainage pans and other adjuncts so far as is practicable. It has not been thought practicable heretofore to gain precious chilled space by keeping the evaporator outside of the thermally insulated cabinet, though location of the evaporator within the cabinet makes more difficult the removal of frost or ice which accumulates on the evaporator and makes the evaporator more difficult to install, adjust, recondition and repair.

Refrigerating systems are subject to many influences which tend to impair their efficiency:

They are subject to extremes of temperature. Certain parts are liable to remain relatively warm while adjacent parts are being chilled. Lubricants, though sealed into the system, may become too hot to retain proper viscosity and to stay where needed.

Accumulated ice and frost must be removed frequently, and removal requires heat that is liable to warm up the interior of the refrigerator to such an extent that the growth of bacteria and fungi is not sufficiently inhibited.

It is desirable that the temperature of certain areas within the refrigerator be kept lower than the temperature at other areas, but it is undesirable that temperature gradients from point to point be casual or indefinite.

In refrigerating apparatus existing prior to this invention, when a compressor motor stopped in response to a reduction in temperature the "head" (i.e. the pressure against which the compressor had been working) was lowered gradually as the refrigerant bled out of the condenser through a restricted passage into the evaporator. The head pressure at the high pressure side of the compressor before the compressor stopped might have ranged upwardly from 150 p.s.i. to 200 p.s.i. or more, while the pressure on the low pressure side might have ranged downwardly from 20 p.s.i. to 8 p.s.i. or less. During the time required in such prior apparatus for

2

the large pressure differential to be reduced sufficiently to permit a motor of practicable size to start without overloading, the temperature within the refrigerator cabinet might rise considerably, especially when the room in which the refrigerator was installed was warm. Prior compressor motor energizing circuits sometimes included safety mechanisms which broke circuits when overloads were encountered and remade the circuits promptly thereafter. Housewives hearing the on and off clicking of such safety devices were prone to become alarmed and to call servicemen to correct the seemingly faulty refrigerating systems.

Because moisture condenses and congeals upon cold parts such as evaporators of refrigerating apparatus where it retards absorption of heat, it is necessary to remove or reduce deposits of ice from time to time to prevent the heat absorption properties of the apparatus from being greatly impaired.

Ice that has been accumulated on an evaporator can be melted by applying hot gas to the evaporator. The manner in which hot gas is applied to the evaporator is of the utmost importance. Either an excess or a deficiency of defrosting heat is deleterious. Heat applied to any part of the evaporator even slightly in excess of that required to melt off ice is worse than wasted. When heat is employed in excess of that to melt off ice an evaporator quickly turns into a heat radiator.

It is an object of this invention to provide a refrigerator in which the average temperature of the air throughout a thermally insulated food cabinet is maintained at a substantially optimum temperature.

It is a further object of the invention to provide a refrigerator in which the temperature gradient from point to point within the thermally insulated cabinet remains substantially definite.

It is a further object to provide a refrigerator the compressor motor of which will when energized start promptly without stalling.

It is a further object to provide a refrigerator in which the interior of the food storage space of the thermally insulated cabinet is unencumbered by refrigerating apparatus.

A further object is to provide a refrigerator in which the interior of the thermally insulated cabinet is substantially free of excessively cold spots whereon ice or frost is liable to accumulate.

A further object is to provide a refrigerator in which minimum warming of the interior of the thermally insulated cabinet occurs while the evaporator is being defrosted.

A further object is to provide a refrigerator having a drainage pan on top and outside the insulated cabinet where drainage water can be evaporated readily by heat from the refrigerating system.

A further object is to provide a refrigerator the contents of which are readily accessible for arrangement or removal.

Another object is to provide a refrigerator which is highly economical in first cost and in operating cost.

Another object is to provide a refrigerator the mechanism of which is readily accessible for service.

And still another object is to provide a refrigerator which is well adapted for installation as a "built-in appliance."

Further objects and numerous advantages of the invention will be apparent upon perusal of the following specification as illustrated by the accompanying drawings in which:

Fig. I is a sectional elevation view of a refrigerator embodying the invention the sectional view being taken as indicated by the line I—I of Fig. II;

Fig. II is a plan view on a somewhat reduced scale of

the refrigerator shown in Fig. I, some of the parts which are hidden by a case being shown by dash lines;

Fig. III is a sectional view on a similarly reduced scale looking upwardly as indicated by the line III—III of Fig. IV;

Fig. IV is a front elevation view on a further reduced scale of the refrigerator shown in Fig. I, the front door of the refrigerator being removed so that the interior can be seen;

Fig. V is a fragmentary sectional view taken as indicated by the line V—V of Fig. II;

Fig. VI is a fragmentary sectional view taken as indicated by the line VI—VI of Fig. II;

Fig. VII is a fragmentary sectional view taken as indicated by the line VII—VII of Fig. I;

Fig. VIII is a diagram of refrigerating and defrosting apparatus that may be incorporated in the refrigerator of this invention; and

Fig. IX is a diagram of a modification of the apparatus diagrammed in Fig. VIII.

This specification and the accompanying drawings describe and illustrate a preferred form of the invention but they are not intended to impose limitations upon its scope.

The invention as described and illustrated herein is embodied in a refrigerator which is intended to be built into a kitchen cabinet structure, preferably at a height above the floor at which the entire interior will be within the range of vision of a housewife and the shelving will be conveniently accessible to her without stooping.

In general, the refrigerator of this invention comprises a thermally insulated cabinet having a hinged thermally insulated front door which may be provided with one or more compartments for conditioning butter, cheese, eggs and other produce that are best preserved in moderately cooled temperatures and may carry door shelves for bottled beverages and the like. The interior of the cabinet is equipped with removable shelves which may be arranged at various heights, and the interior also may contain a so-called "crisper" or "hydrator" compartment to preserve fruits and vegetables without wilting, and a meat container, preferably placed at a location within the box where the temperature is kept low.

In the refrigerator of this invention spaces for the circulation of air are left between the edges of the shelves and the walls and between the "crisper" compartment and the walls and floor, the arrangement of the interior equipment being such that air can circulate among the foods and other articles kept in the refrigerator, the air entering through ports at the upper rear of the interior and leaving through ports at the upper front.

One of the cooperating features of the refrigerator is the location of the refrigerating and defrost apparatus, including the evaporator, outside of and on top of the thermally insulated cabinet so that when the refrigerator is installed the refrigerating apparatus occupies space near the ceiling of the kitchen, the apparatus thus being out of the way by nevertheless more readily accessible than it would be if it were partly within the interior of the insulated cabinet. The apparatus when installed is concealed behind a removable grill or panel of the kitchen cabinet structure.

Other cooperative features of this invention are controlled forced circulation of air through a housing containing the evaporator, where the air is chilled, and the subsequent controlled circulation of the chilled air throughout the interior of the thermally insulated cabinet, and the withdrawal of the air from the interior of the cabinet in a thermally homogenized stream which passes over the bulb or other heat sensitive element of a thermostatic controller which governs the cycles of operation of the refrigerating apparatus.

The thermally insulated cabinet 1 of the refrigerator has outer side walls 2 and 3, an outer rear wall 4, an

outer bottom wall 5, an outer top wall 6, inner side walls 7 and 8, an inner rear wall 9, and a ceiling 10. The front of the cabinet 1 normally is closed by a door 11 having an outer door wall 12 and an inner door wall 13. The space between the outer and inner walls of the cabinet 1 and the door 11 is filled with thermal insulating material.

The door 11 is shown as being equipped with a conditioning compartment 14 for butter, cheese, eggs and other produce and with an upper door shelf 15 and a lower door shelf 16 to support beverages and the like, but any desired door construction may be used in the refrigerator of the instant invention. The cabinet 1 as shown and described herein is equipped with a "crisper" compartment 17 and shelves 18, 19 and 20 and may have a removable covered meat receptacle 21. The equipment is mounted within the cabinet 1 by means of fittings which space the items of equipment away from the inner side walls 7 and 8, inner rear wall 9 and the floor.

Attached to the ceiling 10, just inside of the door 11, is an escutcheon 22 in which are two sets of louvers 23 and 24 which register with exhaust air ports 25 and 26 through the top of the cabinet 1.

Mounted on top of the cabinet 1 is a removable case 27 which contains an evaporator 28 comprising a triple helical coil of tubing 29 having a continuous fin 30 preferably integral therewith. The said tubing is connected to a canister 31, known in this art as an "accumulator," that may extend axially of the triple helical coil of tubing 29. The accumulator 31 adds volumetric capacity to the evaporator to prevent liquid refrigerant from surging through to the compressor. The evaporator 28 is supported in a housing 32 within the case 27, the housing consisting of a lower half or base 33 and an upper half or cover 34 that have matching flanges 35 between which is a gasket 36. The base 33 and the cover 34 both may be made of plastic material molded into shapes which best adapt the housing 32 to serve the multiple purposes of a container for the helical coil of tubing 29, a chamber through which air is circulated about the tubing, a blower and motor emplacement, and a trough for collecting and discharging defrost water.

The base 33 has openings 37 and 38 adjacent the front end of the base, which openings register with the exhaust air ports 25 and 26 in the top of the cabinet 1 and are gasketed to form air tight joints therewith. The base 33 has a chilled air opening 39 adjacent its rear end, which opening registers with the upper end of a fan shaped duct 40 through the top of the cabinet 1 adjacent its rear wall.

A blower motor 50 is mounted at the rear end of the housing 32 and turns a radial discharge blower 51 which draws air from the interior of the cabinet 1 through the louvers 23 and 24, the ports 25 and 26, the exhaust air openings 37 and 38 and over the evaporator tubing 29 and its fin 30. The air flows axially into the blower and radially from the blower through the chilled air opening 39 of the evaporator housing 32 and the fan shaped duct 40 into the interior of the cabinet 1 where the air circulates throughout the interior. To direct air as it enters the cabinet 1 from the evaporator housing 32 for more uniform circulation throughout the interior of the cabinet it is divided into divergent streams by guide vanes 52 and 53 within the fan shaped duct 40.

The space between the case 27 and the evaporator housing 32 is filled with thermal insulation to prevent any appreciable heat exchange between the contents of the evaporator housing and the ambient atmosphere.

Grouped with the evaporator on top of the thermally insulated cabinet 1 are a motorized compressor 56, a condenser 57 and a drainage pan 58. The motorized compressor per se is a commercially available type and the condenser consists of a coil of tubing shaped in a manner to function effectively as a radiator of heat into

the space in which it is installed. The compressor 56 is connected by means of a hot gas conduit 59 to one end of the coil of the condenser 57. It is to be understood that the other end of the coil of the condenser 57 may continue in the form of a coil which is secured to the inner sides of the outer walls 2, 3 and 4 of the refrigerator and which constitutes a continuation of the condenser 57. For the sake of simplicity, however, the condenser is shown as a single coil. The condenser 57 is connected by means of a restricted passage 60 to the end of the evaporator coil tubing 29 remote from the connection between the coil tubing 29 and the accumulator 31, the accumulator 31 being connected in turn to a suction conduit 61 which leads to the compressor 56.

When the compressor is running it pumps refrigerant in the gaseous phase through the hot gas conduit 59 into the condenser 57, in which the refrigerant is cooled and condensed into the liquid phase, and from which it is subsequently emitted through the restricted passage 60 to the evaporator 28 where it absorbs heat from the air that is being drawn by the blower 51 through the evaporator housing 32. Thereafter the refrigerant is evacuated through the suction conduit 61 to be recompressed and reevaporated through successive cycles.

The electric current which energizes the compressor motor is controlled by a thermostatic controller 62 having a heat sensitive element 63, usually called a "bulb," positioned in the air stream drawn by the blower 51 from the interior of the cabinet 1 through the louvers 23. The heat sensitive element 63 in this location is subjected to the temperature of a thermally homogenized stream of air coming from all parts of the interior of the cabinet, instead of being subjected to the temperature of stationary air at any one place within the cabinet which temperature may not be the same as that prevailing elsewhere within the cabinet.

When the average thermally homogenized air temperature affecting the heat sensitive element 63 rises above a predetermined point the thermostatic circuit controller 62 completes the circuit which energizes the compressor motor and thus puts the refrigerating system into operation so that the air drawn over the coil tubing 29 of the evaporator 28 is chilled before being again circulated within the interior of the cabinet 1. When the temperature of the air stream flowing over the heat sensitive element 63 has fallen to a predetermined lower point the thermostatic temperature controller 62 opens the circuit through the compressor motor and the compressor stops.

The refrigerator of this invention is designed to begin cooling cycles upon a very slight elevation of temperature above an optimum level and to terminate cooling cycles at a very slight fall of temperature below the optimum level. It is designed also to defrost with minimum disturbance of its cooling cycles. In accomplishing these purposes the above described air circulating system cooperates with a refrigerant circulating system and controls, preferred forms of which are diagrammed in Figs. VIII and IX.

The thermostatic controller 62 is a commercially available type and therefore is not described in detail herein. It is provided with a manually settable dial 65 which is turnably mounted upon the lower side of the escutcheon 22 to be visible and accessible when the door 11 is opened. The dial 65 is used to increase or decrease the temperatures at which the thermostatic controller is set to close and open a contact 69 which makes and breaks a circuit through a lead 70. When the circuit through the contact 69 and the compressor motor is made the compressor motor starts, and the refrigerant circulating system operates until the temperature to which the heat sensitive element 63 is subjected falls to the predetermined lower temperature for which the thermostatic controller 62 is set to open the contact 69.

Opening of the contact 69 deenergizes the compressor

motor, and closing of the contact 71 activates an electric means such as a solenoid 72 which causes a valve 73 to open a bypass 74 from the hot gas conduit 59 into the evaporator 28.

The purpose of opening the valve 73 during each cycle is to relieve the head against which the compressor must restart and thereby to avoid stalling the compressor motor.

The cooperative relationship in which the valve 73 is held open so long as the motorized compressor 56 is not running is an important feature of this invention. It is this relationship that so conditions the pressure within the system that the compressor starts against little or no head. Closing of the valve 73 simultaneously with starting of the motorized compressor 56 inaugurates the chilling instantly. As the head builds up, the motorized compressor 56 concurrently acquires momentum that insures against stalling.

In addition to the roles that the bypass 74 and the valve 73 play in permitting the use of shorter cooling cycles and in keeping the temperature of the air stream more constant, they also function as important elements of a defrosting system. A defrosting system employing the valve 73 and the by-pass 74 may be set into operation manually, and taken out of operation by a timer or other device after a predetermined interval, or taken out of operation by a thermostatic device when the temperature of a heat sensitive element has reached a predetermined level; or a defrosting system employing the valve 73 and the by-pass 74 may be set into operation by a timer and taken out of operation by a thermostat. For simplicity of illustration, and also because timer control is reliable and relatively inexpensive, a simple timer control is described herein and shown diagrammatically in the accompanying drawings.

As shown in the diagram of Fig. VIII, a timer motor 80 is wired in parallel with the compressor motor so that the timer motor runs whenever the compressor motor runs. Alternatively, the timer motor can be connected to a source of current independently of the compressor motor as indicated by the diagram of Fig. IX, so that the timer motor will run continuously. With either arrangement a timer is constructed and adjusted to actuate a switch after the timer motor has been running for a suitable period such as eight hours during which ice will have been accumulating upon the evaporator coil. The rate at which ice accumulates is dependent upon the relative humidity of the air in the air stream that is drawn through the evaporator. Since the relative humidity usually is higher in warm weather when the compressor motor runs for a greater part of the time to keep the temperature down and since, because of the higher relative humidity, defrosting usually is needed more often on warm days, there is some advantage in causing the timer motor 80 and the timer 81 to run more of the time on the days when the compressor motor runs more of the time.

With circuits arranged as indicated by the diagram of Fig. VIII, when the switch 82 is actuated by the timer 81 a circuit activates the solenoid 72 which causes the valve 73 to open the by-pass 74 from the hot gas conduit 59 into the evaporator 28. The condition of the apparatus when the by-pass is opened in response to the action of the timer 81 is quite different from the condition heretofore described in which the by-pass 74 was opened as a result of action of the thermostatic controller 62. When the by-pass 74 is opened by the timer the compressor 56 continues to run and the fluid refrigerant that travels to the evaporator 28 through the by-pass 74 is not partially cooled fluid that backs out of the condenser, but is newly compressed and heated gas that continues to be pumped by the compressor through the by-pass and into the evaporator.

The timer 81 is designed to keep the circuit through the solenoid 72 closed for a predetermined short interval,

so that the by-pass 74 will remain open long enough to melt the ice that has accumulated, but not long enough to raise the temperature of the evaporator substantially above 32° F.

In the modification diagrammed in Fig. IX the timer motor 80a is connected to the power lines to run continuously. Therefore, whenever either one of the leads 91a or 92a is energized through a contact 69a or 71a in the thermostatic controller 62a, the timer 81a may connect these leads together by closing normally open contacts of a switch 90a, thus ensuring the simultaneous energization of both the compressor or motor and the solenoid 72a. The compressor then instantly starts pumping hot gas through the by-pass 74a and the evaporator 28a, whether or not the motor is stationary at the moment when the timer connects the leads 91a and 92a together. The compressor can initiate the defrosting immediately by starting instantly against little or no head, because with the leads 91a and 92a connected together the solenoid 72a is energized and the valve 73a is open. The cooperative relationship of the elements enables the compressor motor to start and accelerate rapidly for defrosting without bringing safety circuit breakers into play, thus avoiding clicking off and on which may alarm or annoy users.

Another feature of cooperation among the air circulating system, the refrigerant circulating system and the controls is shown in Fig. VIII. It will be observed that whenever the timer 81 closes the circuit through the solenoid 72 to open the by-pass from the hot gas conduit 59 to the evaporator 28, it simultaneously actuates the switch 82 to deenergize the fan motor 50. Hence, air from the interior of the thermally insulated cabinet 1 is not being circulated through the evaporator 28 while the evaporator is being defrosted by hot gas received through the by-pass 74. Of course, it is possible to connect the fan motor 50 directly to the power lines, to cause the fan 51 to operate continuously, but the arrangement shown in Fig. VIII has the advantage that while the evaporator is being heated for the purpose of defrosting it is removed from heat exchange relationship with the air in the cabinet 1, and when the evaporator resumes its function of absorbing heat it is put back into heat exchange relationship with the previously cooled air.

In the grouping of apparatus on top of the cabinet 1 the drainage pan 58 is just beneath the condenser 57 and is juxtaposed to the evaporator 28. The axis of the triple helical coil of tubing 29 and the lower half or base 33 of the evaporator housing 32 slope downwardly and forwardly so that water formed by the melting of frost and ice from the tubing 29 and fin 30 trickles downwardly and forwardly into a sump 83 formed in the base 33. From the sump 83 a drain pipe 84 extends laterally to a point above the drainage pan 58. If the drain pipe 84 is sloped upwardly as shown in Fig. VI, the sump and upwardly extending drain pipe constitute a trap which is closed by water at all times and prevents air from entering the evaporator housing through the drain pipe. The flow from the drain pipe 84 drips into the drainage pan 58 from whence it is evaporated by heat from the condenser 57.

The thermally insulated cabinet 1 with the apparatus grouped upon its top may be merchandised and installed as a self-contained appliance.

An ultraviolet light bulb 85 and an ordinary light bulb 86 are mounted under the ceiling of the thermally insulated cabinet at the rear of the escutcheon 22 so that the rays of ultraviolet light and ordinary light are prevented from shining directly into the eyes of a person looking into the cabinet. A door-operated switch of the usual type may be provided to cause the bulb 86 to be illuminated whenever the door 11 is open. Located immediately inside the door and in front of the escutcheon 22 is a manually operated main switch 87 by means of

which all the electric current to the refrigerator can be switched off or on.

From the foregoing description as illustrated by the accompanying drawings it is clear that the objects of this invention previously outlined have been attained and that the present refrigerator comprises a thermally insulated cabinet the interior of which is uncluttered by refrigeration apparatus and has greater capacity and superior utility for the orderly arrangement of foods, beverages and other articles and commodities to be refrigerated than is attainable in refrigerators having an evaporator occupying the interior of the thermally insulated cabinet.

It also appears that the apparatus described in this specification and illustrated in the accompanying drawings is capable of keeping temperature gradients so distributed within the thermally insulated cabinet that foods such as meat can be kept at lower temperatures than those at which foods such as butter and eggs are kept. Furthermore, it is evident that the apparatus described herein is capable of keeping the average temperature of air circulating through the thermally insulated cabinet at an approximately uniform level and that the apparatus is capable of defrosting its coldest parts with minimum deleterious heating of the contents of the thermally insulated cabinet.

It is to be understood that the refrigerator structure and mechanism described in the foregoing specification and illustrated in the accompanying drawings are exemplary only and that various modifications are within the scope of the invention.

We claim:

1. A refrigerator comprising, in combination, a thermally insulated cabinet adapted to contain food stuffs to be refrigerated, said cabinet having a ceiling with an exhaust air port therein, a housing located on top of said cabinet and having an exhaust air opening registering with the exhaust air port in said ceiling, a refrigerant evaporator within said housing, said housing having a chilled air opening, said ceiling having a chilled air port with which the chilled air opening of said housing is connected, a blower for actively circulating and recirculating air through said chilled air opening and chilled air port, throughout said cabinet to absorb heat from food stuffs, through said registering exhaust air opening and exhaust air port, and through said housing to be recharged, a motorized compressor mounted on top of said cabinet at one side of said housing, a condenser mounted on top of said cabinet at the other side of said housing, a hot gas conduit from said compressor to said condenser, a restricted passage from said condenser to said evaporator, a suction conduit from said evaporator to said compressor, an electric circuit for energizing said motorized compressor, a thermostatic controller for completing or breaking said circuit to energize or deenergize said motorized compressor, said thermostatic circuit controller having a heat sensitive element in the path of air passing through said exhaust air port and means whereby said circuit controller can be set to complete said circuit when the temperature of air passing through said exhaust air port rises to a predetermined high point and can be set to break said circuit when the temperature of air passing through said exhaust air port falls to a predetermined low point, a by-pass for conducting gas around said restricted passage, a valve normally closing said by-pass, and electric means for causing said valve to open said by-pass upon deenergization of said motorized compressor.

2. A refrigerator comprising, in combination, a thermally insulated cabinet adapted to contain food stuffs to be refrigerated, said cabinet having a ceiling with an exhaust air port therein, a housing located on top of said cabinet and having an exhaust air opening registering with the exhaust air port in said ceiling, a refrigerant evaporator within said housing, said housing having a chilled air opening, said ceiling having a chilled air port with which

the chilled air opening of said housing is connected, a blower for actively circulating and recirculating air through said chilled air opening and chilled air port, throughout said cabinet to absorb heat from food stuffs, through said registering exhaust air opening and exhaust air port, and through said housing to be rechilled, a motorized compressor mounted on top of said cabinet at one side of said housing, a condenser mounted on top of said cabinet at the other side of said housing, a hot gas conduit from said compressor to said condenser, a restricted passage from said condenser to said evaporator, a suction conduit from said evaporator to said compressor, an electric circuit for energizing said motorized compressor, a thermostatic controller for completing or breaking said circuit to energize or deenergize said motorized compressor, said thermostatic circuit controller having a heat sensitive element in the path of air passing through said exhaust air port and means whereby said circuit controller can be set to complete said circuit when the temperature of air passing through said exhaust air port rises to a predetermined high point and can be set to break said circuit when the temperature of air passing through said exhaust air port falls to a predetermined low point, a by-pass for conducting gas around said restricted passage, a valve normally closing said by-pass, electric means for causing said valve to open said by-pass upon deenergization of said motorized compressor, a timer having a moving element, and means whereby movement of said element to a predetermined extent causes said valve to open said by-pass independently of any deenergization of said motorized compressor.

3. A refrigerator comprising, in combination, a thermally insulated cabinet adapted to contain food stuffs to be refrigerated, said cabinet having a ceiling with an exhaust air port therein, a housing located on top of said cabinet and having an exhaust air opening registering with the exhaust air port in said ceiling, a refrigerant evaporator within said housing, said housing having a chilled air opening, said ceiling having a chilled air port with which the chilled air opening of said housing is connected, a blower for actively circulating and recirculating air through said chilled air opening and chilled air port, throughout said cabinet to absorb heat from food stuffs, through said registering exhaust air opening and exhaust air port, and through said housing to be rechilled, a motorized compressor, a hot gas conduit from said compressor to said condenser, a restricted passage from said condenser to said evaporator, a suction conduit from said evaporator to said compressor, an electric circuit for energizing said motorized compressor, a thermostatic controller for completing or breaking said circuit to energize or deenergize said motorized compressor, said thermostatic circuit controller having a heat sensitive element in the path of air passing through said exhaust air port, said circuit controller completing said circuit when the temperature of air passing through said exhaust air port rises to a predetermined high point and breaking said circuit when the temperature of air passing through said exhaust air port falls to a predetermined low point, a by-pass for conducting gas around said restricted passage, a valve normally closing said by-pass, and electric means for causing said valve to open said by-pass upon deenergization of said motorized compressor.

4. A refrigerator comprising, in combination, a thermally insulated cabinet adapted to contain food stuffs to be refrigerated, said cabinet having a ceiling with an exhaust air port therein, a housing located on top of said cabinet and having an exhaust air opening registering with the exhaust air port in said ceiling, a refrigerant evaporator within said housing, said housing having a chilled air opening, said ceiling having a chilled air port with which the chilled air opening of said housing is connected, a blower for actively circulating and recirculating air through said chilled air opening and chilled air port, throughout said cabinet to absorb heat from food stuffs,

through said registering exhaust air opening and exhaust air port, and through said housing to be rechilled, a motorized compressor, a hot gas conduit from said compressor to said condenser, a restricted passage from said condenser to said evaporator, a suction conduit from said evaporator to said compressor, an electric circuit for energizing said motorized compressor, a thermostatic controller for completing or breaking said circuit to energize or deenergize said motorized compressor, said thermostatic circuit controller having a heat sensitive element in the path of air passing through said exhaust air port, said circuit controller completing said circuit when the temperature of air passing through said exhaust air port rises to a predetermined high point and breaking said circuit when the temperature of air passing through said exhaust air port falls to a predetermined low point, a by-pass for conducting gas around said restricted passage, a valve normally closing said by-pass, electric means for causing said valve to open said by-pass upon deenergization of said compressor motor, a timer having a moving element, and means whereby movement of said element to a predetermined extent causes said valve to open said by-pass independently of any deenergization of said motorized compressor.

5. A refrigerator comprising, in combination, a thermally insulated cabinet adapted to contain food stuffs to be refrigerated, said cabinet having a ceiling with an exhaust air port therein, a housing located on top of said cabinet and having an exhaust air opening registering with the exhaust air port in said ceiling, a refrigerant evaporator within said housing, said housing having a chilled air opening, said ceiling having a chilled air port with which the chilled air opening of said housing is connected, a blower for actively circulating and recirculating air through said chilled air opening and chilled air port, throughout said cabinet to absorb heat from food stuffs, through said registering exhaust air opening and exhaust air port, and through said housing to be rechilled, a motorized compressor, a hot gas conduit from said compressor to said condenser, a restricted passage from said condenser to said evaporator, a suction conduit from said evaporator to said compressor, an electric circuit for energizing said motorized compressor, a thermostatic controller for completing or breaking said circuit to energize or deenergize said motorized compressor, said thermostatic circuit controller having a heat sensitive element in the path of air passing through said exhaust air port, said circuit controller completing said circuit when the temperature of air passing through said exhaust air port rises to a predetermined high point and breaking said circuit when the temperature of air passing through said exhaust air port falls to a predetermined low point, a by-pass for conducting gas by said restricted passage, a valve normally closing said by-pass, electric means for causing said valve to open said by-pass upon deenergization of said motorized compressor, and to reclose said by-pass upon energization of said motorized compressor, a timer having a moving element, and means whereby movement of said element to a predetermined extent causes said valve to open said by-pass independently of any deenergization of said motorized compressor.

6. A refrigerator comprising, in combination, a thermally insulated cabinet adapted to contain food stuffs to be refrigerated, a housing situated outside of said cabinet, a refrigerant evaporator within said housing, said refrigerant evaporator consisting of a helical coil of tubing, said housing consisting of a base and a cover, said base having a trough-like portion receiving the lower portion of said helical coil of tubing and being substantially evenly spaced therefrom, said trough-like portion having a sump therein, one end of said base being shaped to form an emplacement for a motor and blower, said cover being so shaped that when said cover is assembled with said base and said coil said cover is substantially evenly spaced from said coil, said housing

having a chilled air opening through which chilled air can flow from said housing, said cabinet having a chilled air port through which chilled air from said chilled air opening can flow into said cabinet, said cabinet having an exhaust air port through which air can flow from within said cabinet, said housing having an opening through which air can flow from said exhaust air port into said housing, a blower on said emplacement for actively circulating and recirculating air through said chilled air opening, said chilled air port throughout said cabinet to absorb heat from food stuffs, and through said exhaust air port and said exhaust air opening and through said housing, and means for causing said evaporator to chill air flowing through said housing.

7. A refrigerator comprising, in combination, a thermally insulated cabinet adapted to contain food stuffs to be refrigerated, a housing situated outside of said cabinet, a refrigerant evaporator within said housing, said refrigerant evaporator consisting of a helical coil of tubing, said housing consisting of a base and a cover, said base having a trough-like portion receiving the lower portion of said helical coil of tubing and being substantially evenly spaced therefrom, said trough-like portion having a sump therein, one end of said base being shaped to form an emplacement for a motor and blower, said cover being so shaped that when said cover is assembled with said base and said coil said cover is substantially evenly spaced from said coil, said housing having a chilled air opening through which chilled air can flow from said housing, said cabinet having a chilled air port through which chilled air from said chilled air opening can flow into said cabinet, said cabinet having an exhaust air port through which air can flow from within said cabinet, said housing having an opening through which air can flow from said exhaust air port into said housing, a blower on said emplacement for actively circulating and recirculating air through said chilled air opening, said chilled air port, throughout said cabinet to absorb heat from food stuffs, and through said exhaust air port and said exhaust air opening and through said housing, means for causing said evaporator to chill air flowing through said housing, and a thermostatic controller for governing said means for causing said evaporator to chill air, said thermostatic controller having a heat sensitive element in the path of air passing through said exhaust port.

8. A refrigerator comprising, in combination, a thermally insulated cabinet adapted to contain food stuffs to be refrigerated, a housing situated outside of said cabinet, a refrigerant evaporator within said housing, said refrigerant evaporator consisting of a helical coil of tubing, said housing consisting of a base and a cover, said base having a trough-like portion receiving the lower portion of said helical coil of tubing and being substantially evenly spaced therefrom, said trough-like portion having a sump therein, one end of said base being shaped to form an emplacement for a motor and blower, said cover being so shaped that when said cover is assembled with said base and said coil said cover is substantially evenly spaced from said coil, said housing having a chilled air opening through which chilled air can flow from said housing, said cabinet having a chilled air port through which chilled air from said chilled air opening can flow into said cabinet, said housing having an opening through which air can flow from said exhaust air port into said housing, a blower on said emplacement for actively circulating and recirculating air through said chilled air opening, said chilled air port, throughout said cabinet to absorb heat from food stuffs, and through said exhaust air port and said exhaust air opening and through said housing, means for causing said evaporator to chill air flowing through said housing, means for defrosting said evaporator, and means for discontinuing such circulating and recirculating of air during defrosting.

9. Refrigerating mechanism comprising, in combination, a compressor motor, a compressor, a condenser, a hot gas conduit from said compressor to said condenser, an evaporator, a restricted passage from said condenser to said evaporator, a suction conduit from said evaporator to said compressor, a by-pass from said hot gas conduit to beyond said restricted passage, a valve for opening and closing said by-pass conduit, electrically operated means controlling said valve, an electric circuit for energizing said electrically operated means, a compressor motor circuit for energizing said compressor motor, a thermostatic controller acting in response to a fall in temperature to a predetermined level for breaking said compressor motor circuit, thus deenergizing said compressor motor circuit, and simultaneously completing said electric circuit for energizing said electrically operated means, whereby said valve is opened when said compressor is stopped, said thermostatic controller acting in response to a rise in temperature to a predetermined level to complete said compressor motor circuit and break said electric circuit for deenergizing said electrically operated means, whereby said valve closes when said compressor is started, a timer for periodically connecting said compressor motor circuit to said electric circuit for energizing said electrically operated means controlling said valve, and thereby keeping said compressor running while keeping said valve open, and means whereby said timer disconnects said circuits from each other after a predetermined interval.

10. A refrigerator comprising, in combination; a thermally insulated cabinet; a housing situated outside of said cabinet; said cabinet having an exhaust air port communicating with said housing located adjacent a door opening of said cabinet; an evaporator within said housing; refrigeration means causing said evaporator to chill air in said housing; said housing having a chilled air opening communicating with said cabinet; means circulating air into said exhaust port and out said chilled air opening; a thermostatic circuit controller for said refrigeration means having a heat sensitive element disposed in the path of air flowing within said exhaust port.

11. A refrigerator comprising, in combination; a thermally insulated cabinet having a front door, rear, and side walls, and a ceiling; a housing situated on top of said cabinet; said cabinet having an exhaust air port adjacent said front door communicating with said housing; an evaporator located in said housing; refrigerant means causing said evaporator to chill air in said housing; a chilled air opening in said housing communicating with said cabinet; means circulating air into said exhaust port and out said chilled air opening into said cabinet; a thermostatic circuit controller for said refrigeration means having a heat sensitive element disposed in the path of air flowing within said exhaust port.

12. Refrigeration apparatus comprising, in combination; a thermally insulated cabinet; a housing situated outside of said cabinet; said cabinet having exhaust and chilled air ports communicating with said housing; an evaporator within said housing; refrigeration means comprising a compressor for circulating refrigerant through said evaporator, and means effective during a refrigeration cycle and operative only when said compressor stops for reducing the pressure against which said compressor must work, thereby allowing said compressor to start again immediately without overloading; means for circulating air into said exhaust and out of said chilled air ports; and a thermostatic controller for said refrigeration means having a heat sensitive element disposed within the path of air flowing within said exhaust port.

## References Cited in the file of this patent

## UNITED STATES PATENTS

2,800,773	Crew	July 30, 1957
2,812,642	Jacobs	Nov. 12, 1957