



- (51) International Patent Classification:
F16B 31/02 (2006.01) G01L 5/24 (2006.01)
- (21) International Application Number:
PCT/US2015/038137
- (22) International Filing Date:
26 June 2015 (26.06.2015)
- (25) Filing Language: English
- (26) Publication Language: English
- (30) Priority Data:
62/018,229 27 June 2014 (27.06.2014) US
- (71) Applicant: HUBBELL INCORPORATED [US/US]; 40 Waterview Drive, Shelton, CT 06484-1000 (US).
- (72) Inventors: DE FRANCE, Robert, Victor; 48 Catskill Avenue, Poughkeepsie, NY 12603 (US). DORBRINSKI, Daniel, David; 58 Fefferson Drive, Hillsboro, NH 03244 (US). HALL, Jefferson, Robert; 114 School Street, Concord, NH 03301 (US).
- (74) Agent: MCMAHON, Edward, L.; Ohlandt, Greeley, Ruggiero & Perle, L.L.P., One Landmark Square, 10th Floor, Stamford, CT 06901-2682 (US).

- (81) Designated States (unless otherwise indicated, for every kind of national protection available): AE, AG, AL, AM, AO, AT, AU, AZ, BA, BB, BG, BH, BN, BR, BW, BY, BZ, CA, CH, CL, CN, CO, CR, CU, CZ, DE, DK, DM, DO, DZ, EC, EE, EG, ES, FI, GB, GD, GE, GH, GM, GT, HN, HR, HU, ID, IL, IN, IR, IS, JP, KE, KG, KN, KP, KR, KZ, LA, LC, LK, LR, LS, LU, LY, MA, MD, ME, MG, MK, MN, MW, MX, MY, MZ, NA, NG, NI, NO, NZ, OM, PA, PE, PG, PH, PL, PT, QA, RO, RS, RU, RW, SA, SC, SD, SE, SG, SK, SL, SM, ST, SV, SY, TH, TJ, TM, TN, TR, TT, TZ, UA, UG, US, UZ, VC, VN, ZA, ZM, ZW.
- (84) Designated States (unless otherwise indicated, for every kind of regional protection available): ARIPO (BW, GH, GM, KE, LR, LS, MW, MZ, NA, RW, SD, SL, ST, SZ, TZ, UG, ZM, ZW), Eurasian (AM, AZ, BY, KG, KZ, RU, TJ, TM), European (AL, AT, BE, BG, CH, CY, CZ, DE, DK, EE, ES, FI, FR, GB, GR, HR, HU, IE, IS, IT, LT, LU, LV, MC, MK, MT, NL, NO, PL, PT, RO, RS, SE, SI, SK, SM, TR), OAPI (BF, BJ, CF, CG, CI, CM, GA, GN, GQ, GW, KM, ML, MR, NE, SN, TD, TG).

Declarations under Rule 4.17:

— of inventorship (Rule 4.17(iv))

Published:

— with international search report (Art. 21(3))

[Continued on next page]

(54) Title: TORQUE INDICATING THREADED MECHANICAL FASTENING SYSTEMS AND METHODS

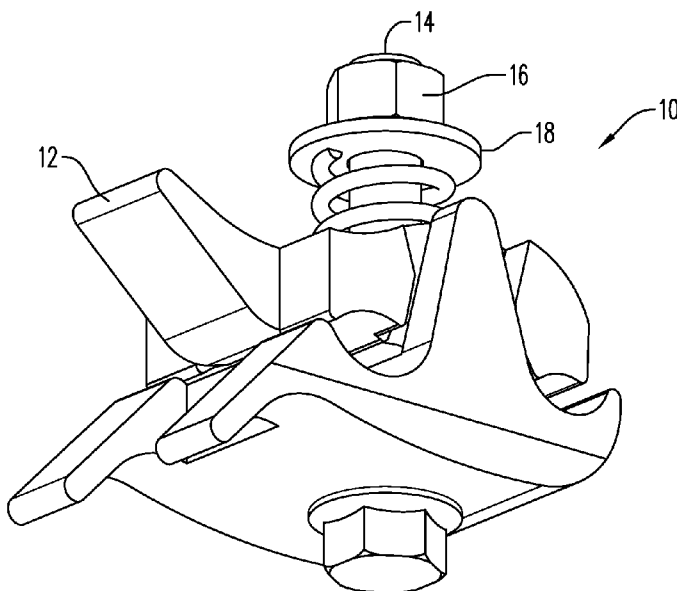

FIG. 1

(57) Abstract: Threaded mechanical fastening systems and methods are provided that allow the simple deflection of a washer to indicate that a desired minimum torque has been reached or that a desired maximum torque has been exceeded. The method includes providing a threaded connection having a washer, installing the threaded connection so that the washer is supported as a simple beam over a gap, and using an amount of deflection of the washer as a result of torque applied by the threaded connection as an indicator. The torque indicating threaded mechanical fastening system includes a threaded connection and a washer supported as a simple beam over a gap so that the threaded connection, when tightened to a pre-determined torque, deflects, in bending, the washer into the gap.

WO 2015/200867 A1

- *before the expiration of the time limit for amending the claims and to be republished in the event of receipt of amendments (Rule 48.2(h))*

TORQUE INDICATING THREADED MECHANICAL
FASTENING SYSTEMS AND METHODS

BACKGROUND OF THE INVENTION

1. Field of the Invention

[0001] The present disclosure is related to threaded mechanical fastening systems and methods. More particularly, the present disclosure is related to threaded mechanical fastening systems and methods that provide an indication of torque during assembly of the system. In some embodiments, the threaded mechanical fastening systems and methods are calibrated so that the indication is a sign of over torque, while in other embodiments the indication is a sign of a desired torque level.

2. Description of Related Art

[0002] Threaded mechanical fastening systems have been used to connect various components to one another for many years. The over tightening of the threaded mechanical fastening system can potentially damage one or more portions of the fastening system and/or one or more of the components that the fastening system is being used to connect.

[0003] In some instances and in order to prevent damage, a special device that measures and/or limits the torque applied during the assembly of the components and threaded mechanical fastening system. For example, some prior art assembly operations require the use of a torque measuring device – such as but not limited to a torque wrench. Other prior art assembly operations require the use of a torque limiting device – such as, but not limited to, a torque clutch.

[0004] Unfortunately, it has been determined by the present disclosure that the use of such special tools often adds complexity and/or cost to the assembly.

[0005] Accordingly, there is a need for threaded mechanical fastening systems and methods that overcome, alleviate, and/or mitigate one or more of the aforementioned and other deleterious effects of prior art systems.

SUMMARY

[0006] Threaded mechanical fastening systems and methods are provided that allow the simple deflection of a washer to indicate that a desired minimum torque has been reached or that a desired maximum torque has been exceeded.

[0007] Threaded mechanical fastening systems are provided that, in most basic form, include a threaded connection and a washer supported as a simple beam. In this position, the washer forms a structural member that is deflected by tightening the threaded connection to or above a predetermined torque.

[0008] The above-described and other features and advantages of the present disclosure will be appreciated and understood by those skilled in the art from the following detailed description and drawings.

BRIEF DESCRIPTION OF THE DRAWINGS

[0009] FIG. 1 is a bottom perspective view of an exemplary embodiment of a threaded mechanical fastening system according to the present disclosure;

[0010] FIG. 2 is a side view of the threaded mechanical fastening system of FIG. 1;

[0011] FIG. 3 is a bottom view of the threaded mechanical fastening system of FIG. 1;

[0012] FIG. 4 is a top view of the threaded mechanical fastening system of FIG. 1;

[0013] FIG. 5 is a first end view of the threaded mechanical fastening system of FIG. 1;

[0014] FIG. 6 is a second end view of the threaded mechanical fastening system of FIG. 1;

[0015] FIG. 7 is a first end view of an upper pad of the threaded mechanical fastening system of FIG. 1;

[0016] FIG. 8 is a second end view of the threaded mechanical fastening system of FIG. 1 in use at a first torque;

[0017] FIG. 9 is a second end view of the threaded mechanical fastening system of FIG. 1 in use at a second torque;

[0018] FIG. 10 is a second end view of the threaded mechanical fastening system of FIG. 1 in use at a third torque;

[0019] FIG. 11 is a first end view of the threaded mechanical fastening system of FIG. 1 in use at a fourth torque;

[0020] FIG. 12 illustrates an exemplary embodiment of boundary conditions on the washer of FIG. 1 during loading for use in a finite element analysis (FEA);

[0021] FIG. 13 illustrates an FEA resultant displacement plot of the washer at the second torque as shown in FIG. 9;

[0022] FIG. 14 illustrates an FEA stress plot of the washer at the second torque as shown in FIG. 9;

[0023] FIG. 15 illustrates an FEA resultant displacement plot of the washer at the third torque as shown in FIG. 10;

[0024] FIG. 16 illustrates an FEA stress plot of the washer at the third torque as shown in FIG. 10;

[0025] FIG. 17 illustrates an FEA resultant displacement plot of the washer at the fourth torque as shown in FIG. 11;

[0026] FIG. 18 illustrates an FEA stress plot of the washer at the fourth torque as shown in FIG. 11;

[0027] FIG. 19 illustrates an exemplary embodiment of boundary conditions on the upper pad of FIG. 1 during loading for use in FEA;

[0028] FIG. 20 illustrates an FEA section view stress plot of the upper pad at the third torque as shown in FIG. 10;

[0029] FIG. 21 illustrates an FEA stress plot of the upper pad at the third torque as shown in FIG.10;

[0030] FIG. 22 illustrates an FEA section view stress plot of the upper pad at 535 inch-pounds of torque;

[0031] FIG. 23 illustrates an FEA stress plot of the upper pad at 535 inch-pounds of torque;

[0032] FIG. 24 is a first end view of an alternate exemplary embodiment of a threaded mechanical fastening system according to the present disclosure;

[0033] FIG. 25 is a top view of the threaded mechanical fastening system of FIG. 24; and

[0034] FIG. 26 is a first end view of an upper pad of the threaded mechanical fastening system of FIG. 24.

DETAILED DESCRIPTION

[0035] Referring to the drawings and in particular to FIGS. 1 through 7, an exemplary embodiment of a threaded mechanical fastening system according to the present disclosure is shown and is generally referred to by reference numeral 10.

[0036] System 10 is shown by way of example incorporated into a spring loaded parallel pad clamp such as that shown and described in U.S. Patent No. 7,666,024. For reasons of brevity, only the portions of the spring loaded parallel pad clamp that are necessary for understanding of system 10 will be described herein, while the remaining portions will be omitted for reasons of brevity. Specifically, system 10 includes an upper pad 12, a threaded connection consisting of a bolt 14 and a nut 16, and a washer 18. Advantageously, system 10 includes is configured so deflection of washer 18 can be an indication over torque of the system or an indication of a desired torque level.

[0037] For example, system 10 can be calibrated so that washer 18 does not deflect at the desired system torque. Here, system 10 can be used to verify that excess torque was not applied. Stated another way, any deflection of washer 18 in this embodiment would be an indication that more than a desired amount of torque had been applied.

[0038] Alternately, system 10 can be calibrated so that washer 18 begins deflecting at a desired torque. Here, system 10 can be used as an indication that the correct torque has been applied. Stated another way, the operator can apply torque to system 10 in this embodiment until washer 18 begins to deflect, which would be an indication that a desired amount of torque had been applied.

[0039] It should be recognized that washer 18 is illustrated herein by way of example only as a flat washer. Of course, it is contemplated by the present disclosure for washer 18 to have any configuration such, as but not limited, to a Bellville washer, split washers, fender washers, internal tooth lock washers, external tooth lock washers, finishing washers, and others.

[0040] Referring now to FIG. 7, an end view of upper pad 12 is shown. The deflection of washer 18 is made possible by providing a gap 20 in upper pad 12. In this manner, the edges of gap 20 act as landings 22 that support washer 18 as a “simple beam”, namely where the washer is supported at two outer extents.

[0041] Accordingly, system 10, in its most basic form, a threaded connection and a washer supported as a simple beam. In this position, washer 18 forms a structural member of the connection.

[0042] Referring now to FIGS. 8 through 11, system 10 is shown in use at different levels of torque. As is shown, the torque applied to the threaded connection (i.e., bolt and nut 14, 16) causes the threaded member to apply a linear force 24 onto washer 18. The linear force 24 in combination with the simple beam support of washer 18 result in deflection of the washer when the linear force reaches a predetermined level.

[0043] System 10 can be calibrated by adjusting one or more parameters so that the same level of torque results in different levels of deflection of washer 18.

[0044] Various properties of washer 18 that can be used to calibrate system 10 include, but are not limited to, a material, a thickness, internal washer diameter (ID), outer washer diameter (OD), heat treatment, and others.

[0045] Gap 20 can also be adjusted to calibrate system 10, where a larger gap can result in increased deflection at a certain torque, while a smaller gap can result in decreased deflection at that same torque. It should be noted that there is a lower limit below which gap 20 cannot be reduced. Specifically, linear force 24 is applied to washer 18 in a contact region 26. Thus, gap 20 must be larger than contact region 26 to ensure that washer 18 remains supported as a simple beam.

[0046] Similar to gap 20 discussed above, contact region 26 can be adjusted to calibrate system 10, where a smaller contact region can result in increased deflection at a certain torque, while a larger contact region can result in decreased deflection at that same torque.

In the illustrated embodiment, contact region 26 is shown being applied by a second washer 28 that is disposed between nut 16 and washer 18. Here, second washer 28 is shown as a lock washer that has a smaller contact region than that of nut 16. Of course, it is contemplated by the present disclosure for second washer 28 to have a contact region that is the same as nut 16 or is larger contact region than that of nut 16 – again provided that gap 20 is be larger than contact region 26 to ensure that washer 18 remains supported as a simple beam.

[0047] Without wishing to be bound by any particular theory, it is believed that, given the common deflection characteristics of washer 18 when configured as a simple supported beam disclosed herein that it is desired for the washer to extend far enough from the bolt to allow deflection at the designed torque/clamping force. Thus in some embodiments, gap 20 has a width that is approximately 60% larger than a diameter of the shaft of bolt 14 and the outer diameter (OD) of the washer 18 is approximately 60% larger than the width of gap 20. Of course, it is contemplated by the present disclosure for washer 18 to have any desired width and or diameter necessary to calibrate the system to the desired torque and use.

[0048] System 10 is shown in FIGS. 8 through 11 having different torque levels applied to illustrate the resulting deflection of washer 18.

[0049] In FIG. 8, system 10 is shown after application of a torque of 180 inch-pounds, which is sufficient to deflect washer 18. The deflection results in a distance 30 between a point on upper pad 12 and a bottom of washer 18 being decreased by about .012 inches.

[0050] In FIG. 9, system 10 is shown after application of a torque of 200 inch-pounds, which is sufficient to result in distance 30 being decreased by about .015 inches. In FIG. 10, system 10 is shown after application of a torque of 250 inch-pounds, which is sufficient to result in distance 30 being decreased by about .019 inches. In FIG. 11, system 10 is shown after application of a torque of 300 inch-pounds, which is sufficient to result in distance 30 being decreased by about .021 inches.

[0051] Accordingly, system 10 can be calibrated during design to provide a desired deflection at a given torque. In some embodiments, system 10 can be calibrated so that washer 18 does not deflect at the desired system torque so that the system can be used to verify whether excess torque was applied. Alternately, system 10 can be calibrated so that washer 18 begins deflecting at a desired torque so that the system 10 can be used to determine when to stop tightening the threaded connection.

[0052] In some embodiments, system 10 can include one or more indicators, which allow the user to be able to visually verify the amount of deflection. For example, system 10 can include minimum and maximum deflection marks 32, 34 on pad 12 as shown in FIG. 9. Here, the user can ensure that washer 18 is deflected between the desired marks 32, 34. In another example, system 10 can include only a maximum deflection mark 32 or only a minimum deflection mark 34.

[0053] In yet another example shown in FIG. 10, system 10 can include a protrusion 36 on pad 12 extending towards washer 18. In use, system 10 can be tightened and as long as washer 18 does not contact the protrusion 36, the user can be assured that the system has not exceeded the maximum torque.

[0054] It should be recognized that the threaded connection is shown in the example provided above as bolt 14 and nut 16. However, it should be recognized that the present disclosure finds equal use with any threaded connection such as, but not limited to, screws including wood screws, machine screws, thread cutting screws, sheet metal screws, self-drilling screws, socket screws, and others, bolts including hex bolts, lag bolts, carriage bolts, eye bolts, U bolts, shoulder bolts, and others.

[0055] Moreover, system 10 is shown in the example provided above incorporated into a spring loaded parallel pad clamp such that the simple beam support of the washer is formed by gap 20. It should be recognized that the present disclosure finds equal use anywhere that a threaded connection is used.

[0056] In the example where system 10 is incorporated into a spring loaded parallel pad clamp many of such pads are made from a cast process (e.g., sand cast, die cast, shell mold casting, investment cast, and others). The castings can crack when system 10 is tightened beyond the recommended torque. Accordingly, system 10 can be used to ensure that excess torque is not applied – by giving a visual indication through the aforementioned deflection of washer 18. Again, the deflection of washer 18 can indicate that too much torque was applied such that a new spring loaded parallel pad clamp should be applied. Alternately, the beginning of deflection of washer 18 can indicate that the correct torque has been applied such that further torque is not necessary.

[0057] Referring now to FIGS. 12 through 23, an exemplary embodiment of a Finite Element Analysis (FEA) of system 10 is shown. FIG. 12 illustrates an exemplary embodiment of boundary conditions on washer 18 during loading, while FIG. 19 illustrates an exemplary embodiment of boundary conditions on upper pad 12 of FIG. 1 during loading.

[0058] The resultant deflection and stress on washer 18 at the boundary conditions of FIG. 12 are illustrated in FIGS. 13 and 14 at 200 inch-pounds of torque, in FIGS. 15 and 16 at 250 inch-pounds of torque, and in FIGS. 17 and 18 at 300 inch-pounds of torque.

[0059] Additionally, the resultant stress and pressure on upper pad 12 at the boundary conditions of FIG. 19 are illustrated in FIGS. 20 and 21 at 250 inch-pounds of torque and in FIGS. 22 and 23 at 535 inch-pounds of torque.

[0060] Referring now to FIGS. 24 through 26, an alternate exemplary embodiment of a threaded mechanical fastening system according to the present disclosure is shown and is generally referred to by reference numeral 10'. Description of components parts performing similar or analogous functions to those described with respect to the embodiment of FIG. 1 are omitted for reasons of brevity.

[0061] In this embodiment, upper pad 12' is configured so that landings 22 further include a washer guide edge 22'. It has been determined that centering of washer 18 with respect to gap 20 can be desired in some embodiments. Accordingly, edge 22' is positioned on both

sides of gap 20 and assists in ensuring that washer 18 remains centered over the gap. In some embodiments, edge 22' can include a chamfer to ensure that washer 18 seats on landings 22 in a centered manner.

[0062] Of course, it should be recognized that the centering of washer 18 over gap 20 is described above by way of example only as edge 22' acting on the washer. However, it is also contemplated by the present disclosure for system 10' to include one or more features (e.g., edge 22') that act on one or more of washer 18, bolt 14, nut 16, and any combinations thereof so as to ensure that washer remains centered with respect to gap 20. The centering feature can be incorporated into upper pad 12' and/or into the lower pad 12'' and/or can be a separate centering component.

[0063] It should also be noted that the terms "first", "second", "third", "upper", "lower", and the like may be used herein to modify various elements. These modifiers do not imply a spatial, sequential, or hierarchical order to the modified elements unless specifically stated.

[0064] While the present disclosure has been described with reference to one or more exemplary embodiments, it will be understood by those skilled in the art that various changes may be made and equivalents may be substituted for elements thereof without departing from the scope of the present disclosure. In addition, many modifications may be made to adapt a particular situation or material to the teachings of the disclosure without departing from the scope thereof. Therefore, it is intended that the present disclosure not be limited to the particular embodiment(s) disclosed as the best mode contemplated, but that the disclosure will include all embodiments falling within the scope of the appended claims.

CLAIMS

What is claimed is:

1. A method of using washer deflection as a torque indicator as shown and described.
2. A method of using washer deflection as a torque indicator, comprising:
providing a threaded connection having a washer;
installing the threaded connection so that the washer is supported as a simple beam over a gap; and
using an amount of deflection of the washer as a result of torque applied by the threaded connection as an indicator the amount of torque applied.
3. The method of claim 2, wherein the indicator is an indication that a desired minimum torque has been reached.
4. The method of claim 2, wherein the indicator is an indication that a desired maximum torque has been exceeded.
5. A torque indicating threaded mechanical fastening system as shown and described.
6. A torque indicating threaded mechanical fastening system, comprising:
a threaded connection; and
a washer supported as a simple beam over a gap so that the threaded connection, when tightened to a predetermined torque, deflects, in bending, the washer into the gap.
7. The system of claim 6, wherein the predetermined torque is a minimum torque such that the bending is an indication that the minimum torque has been reached.
8. The system of claim 6, wherein the predetermined torque is a maximum torque such that the bending is an indication that the maximum torque has been exceeded.

9. A spring loaded pad clamp, comprising:
 - a deflection washer having an outer dimension;
 - a threaded connection including a bolt and a nut;
 - an upper pad having a gap having edges that support the outer dimension of the deflection washer, the threaded connection having a portion that passes through the deflection washer and the gap, the threaded connection having a contact region that contacts the deflection washer, the gap being larger than the contact region so that the threaded connection, when tightened to a predetermined torque, deflects, in bending, the deflection washer into the gap.

10. The clamp of claim 9, wherein the predetermined torque is a minimum torque such that the bending is an indication that the minimum torque has been reached.

11. The clamp of claim 9, wherein the predetermined torque is a maximum torque such that the bending is an indication that the maximum torque has been exceeded.

12. The clamp of claim 9, wherein the predetermined torque is dependent upon at least one property of the deflection washer selected from the group consisting of a material, a thickness, an internal washer diameter, an outer washer diameter, and a heat treatment.

13. The clamp of claim 12, wherein the predetermined torque is dependent upon a width of the gap.

14. The clamp of claim 9, wherein the contact region comprises a region of contact between the deflection washer and either a head of the bolt or the nut.

15. The clamp of claim 9, wherein the contact region comprises a region of contact between the deflection washer and a second washer positioned between the deflection washer and either a head of the bolt or the nut.

16. The clamp of claim 9, wherein the gap has a width that is 60% larger than a diameter of a shaft of the bolt and the deflection washer has an outer diameter that is 60% larger than the width of gap.

17. The clamp of claim 9, wherein the edges of the gap further comprise a washer guide edge sufficient to center the deflection washer with respect to the gap.

18. The clamp of claim 9, wherein the edges of the gap further comprise a chamfer sufficient to center the deflection washer with respect to the gap.

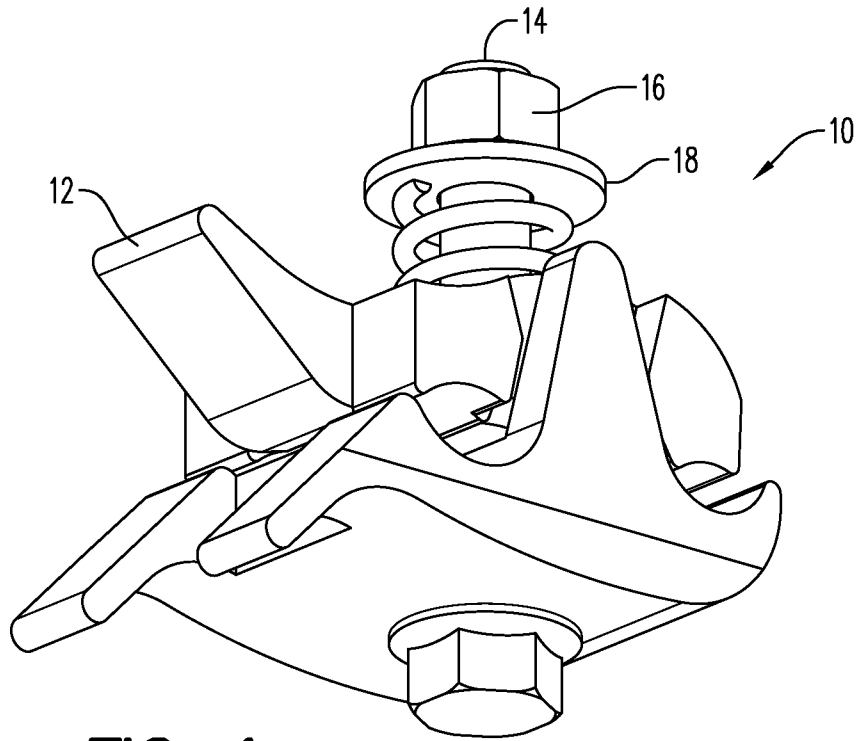

FIG. 1

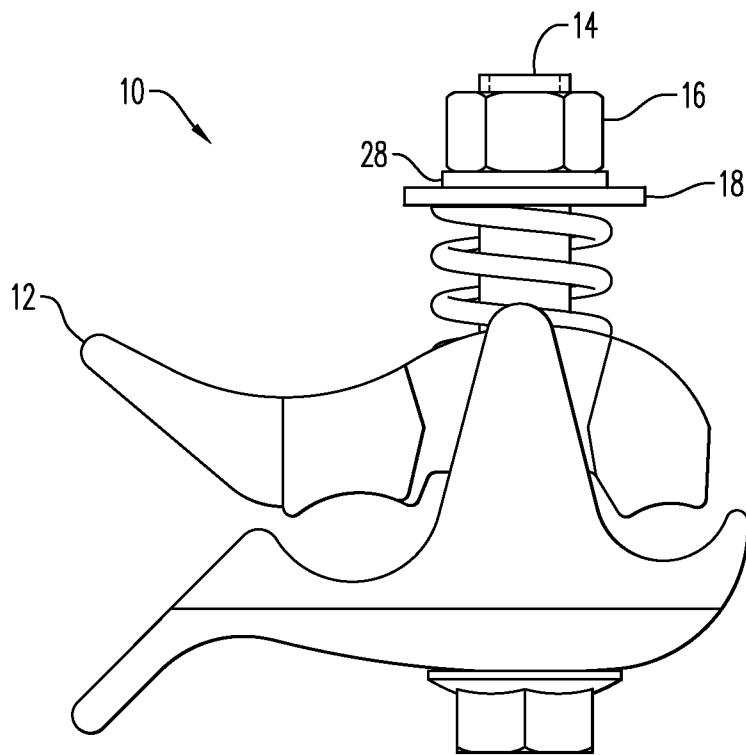

FIG. 2

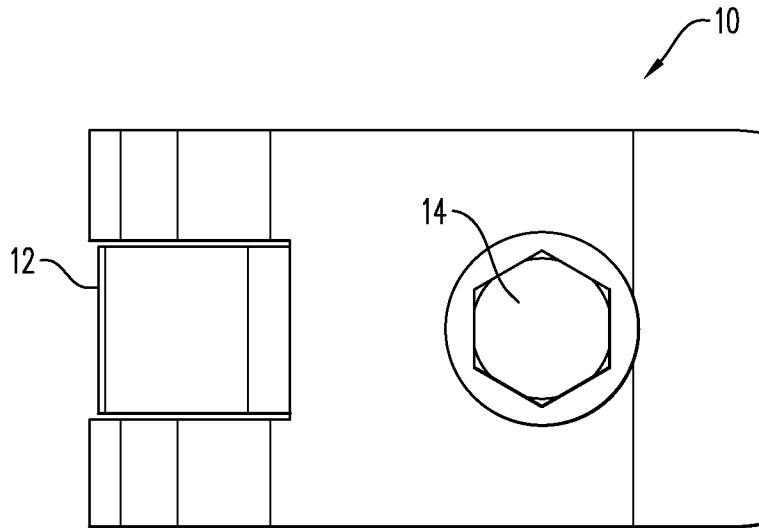

FIG. 3

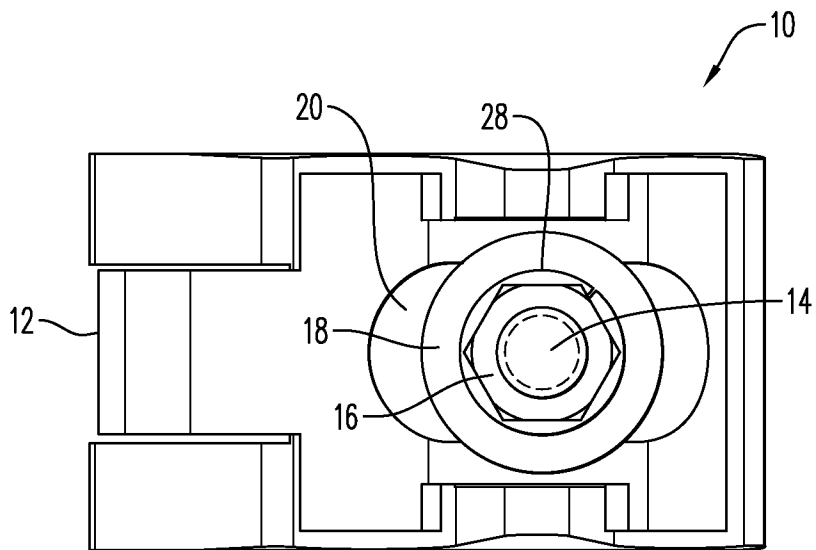

FIG. 4

3/16

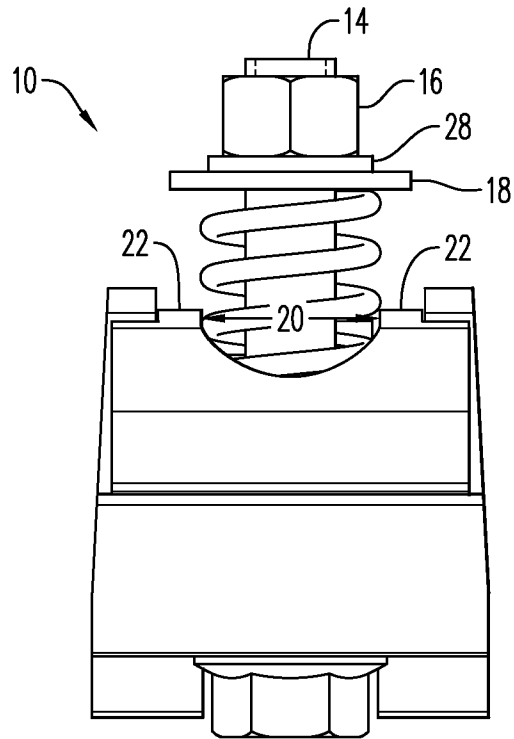

FIG. 5

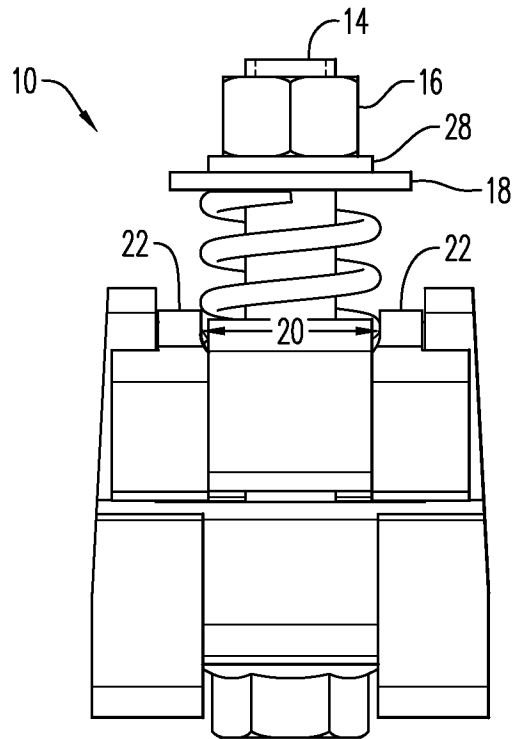

FIG. 6

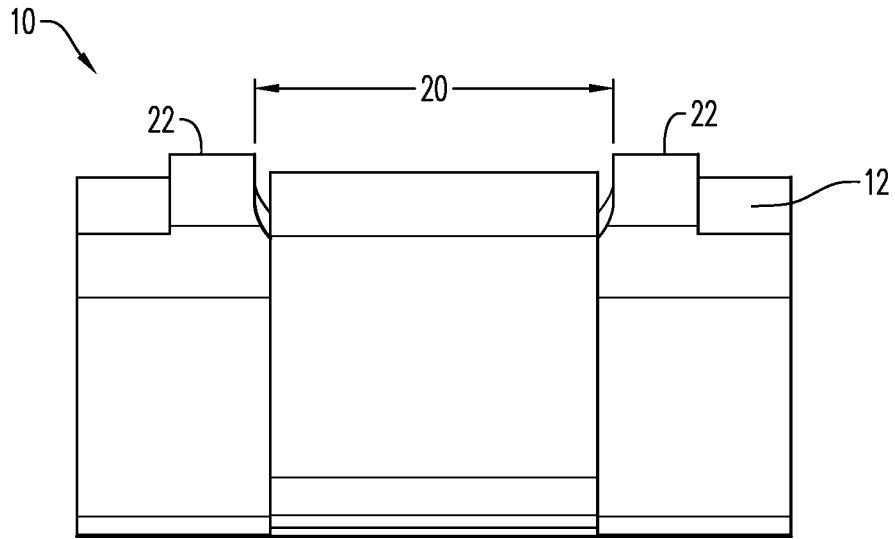

FIG. 7

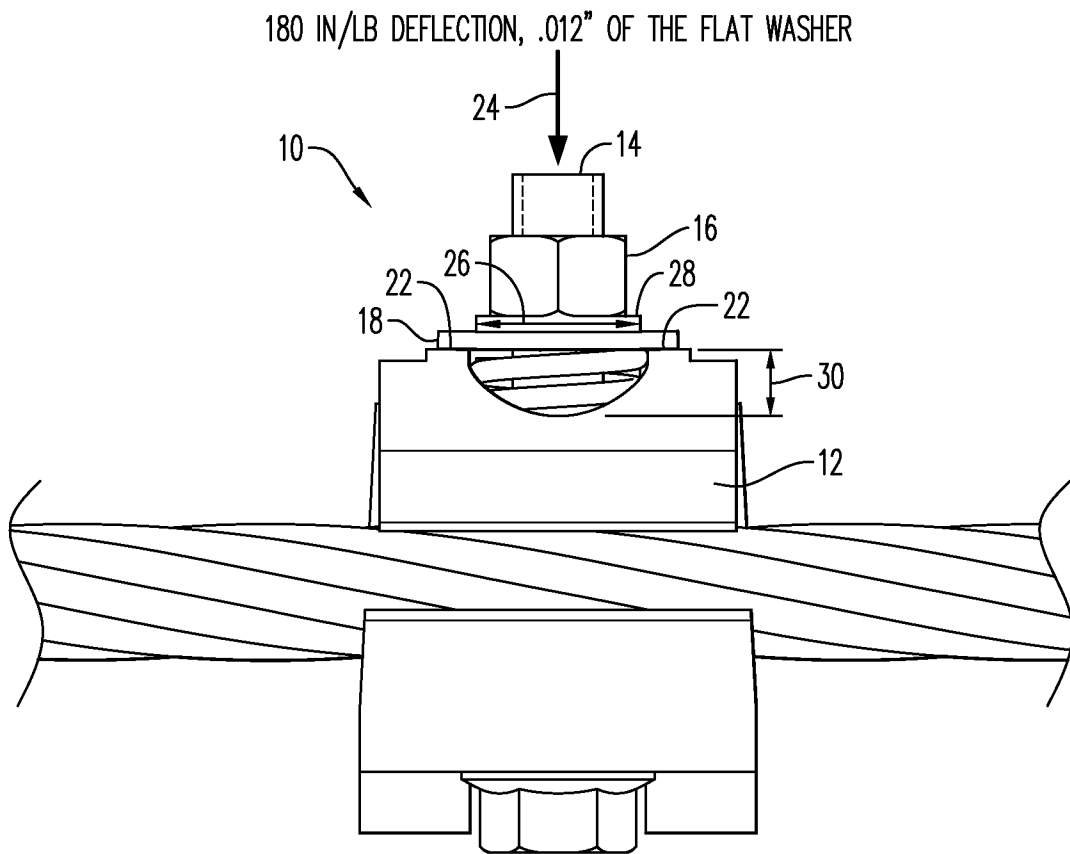

FIG. 8

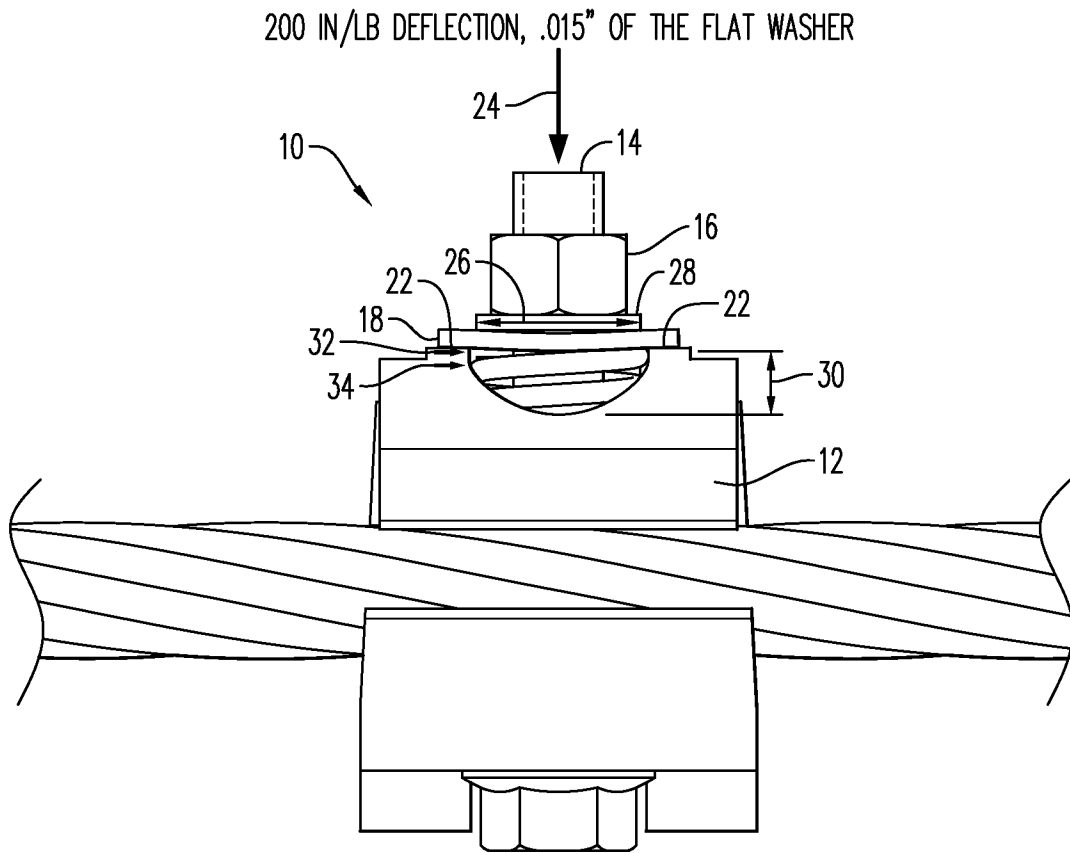

FIG. 9

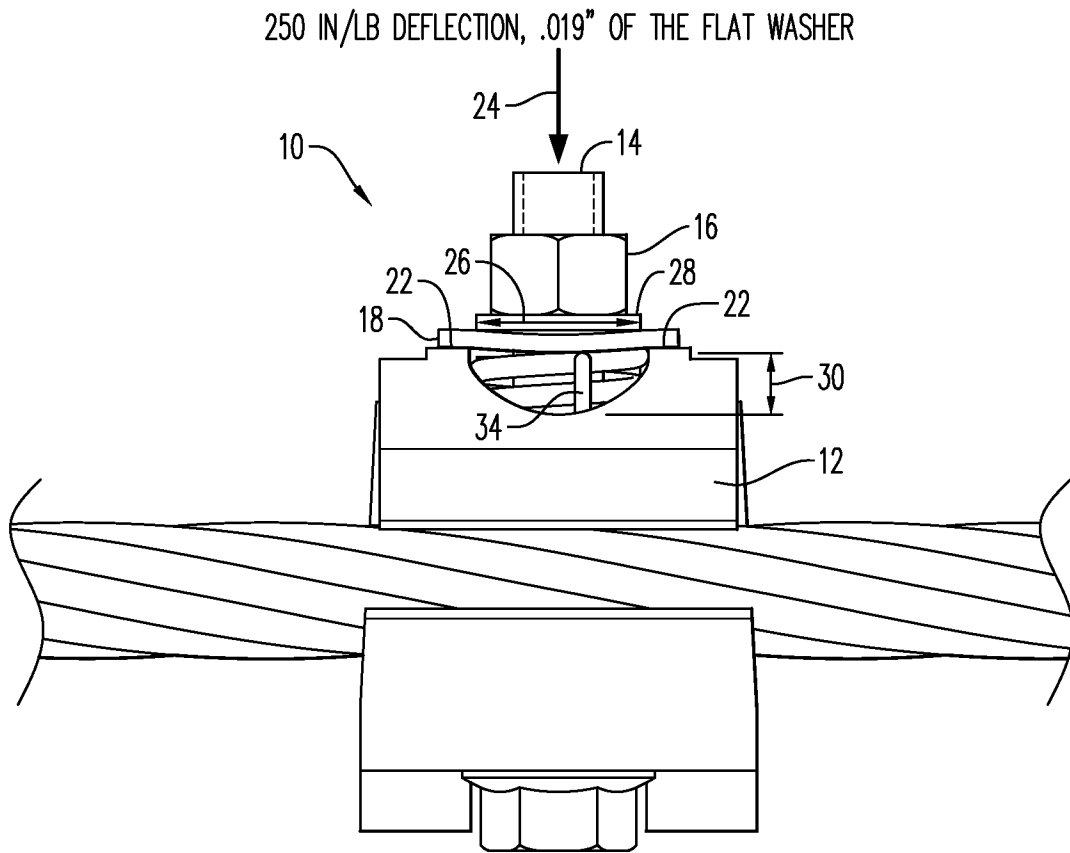

FIG. 10

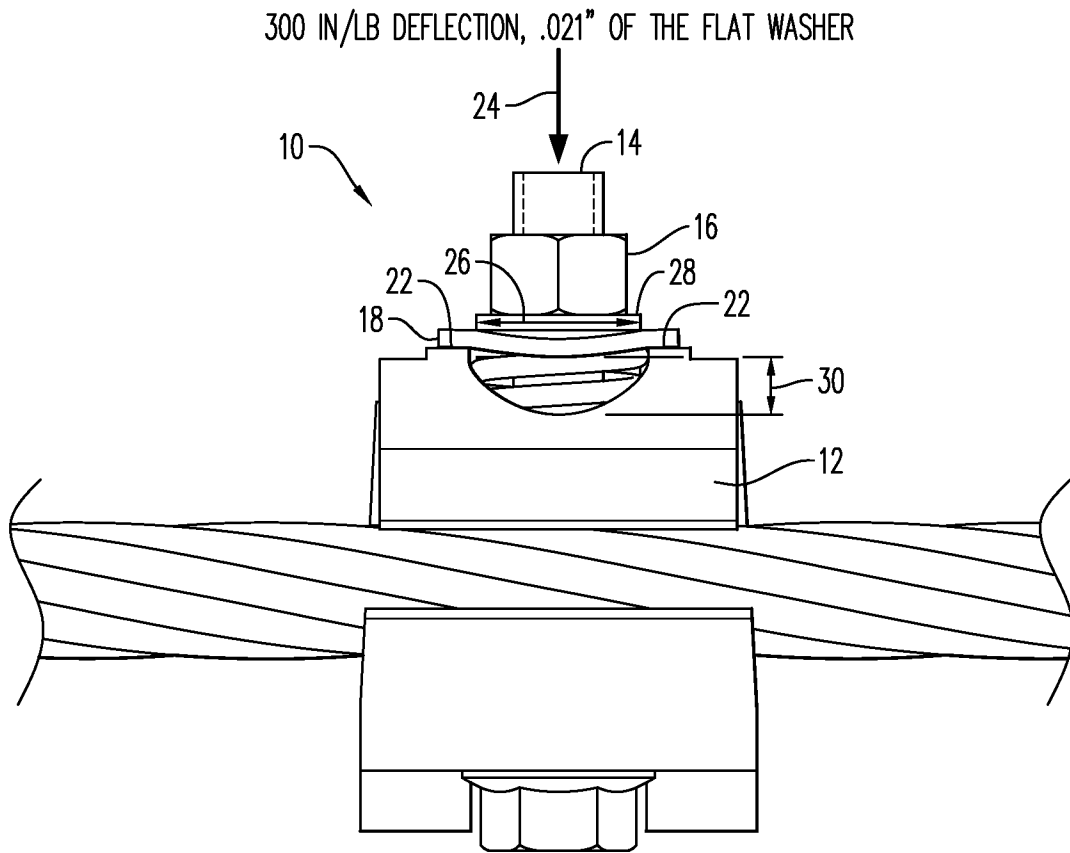

FIG. 11

WASHER LOADING/BOUNDARY CONDITIONS

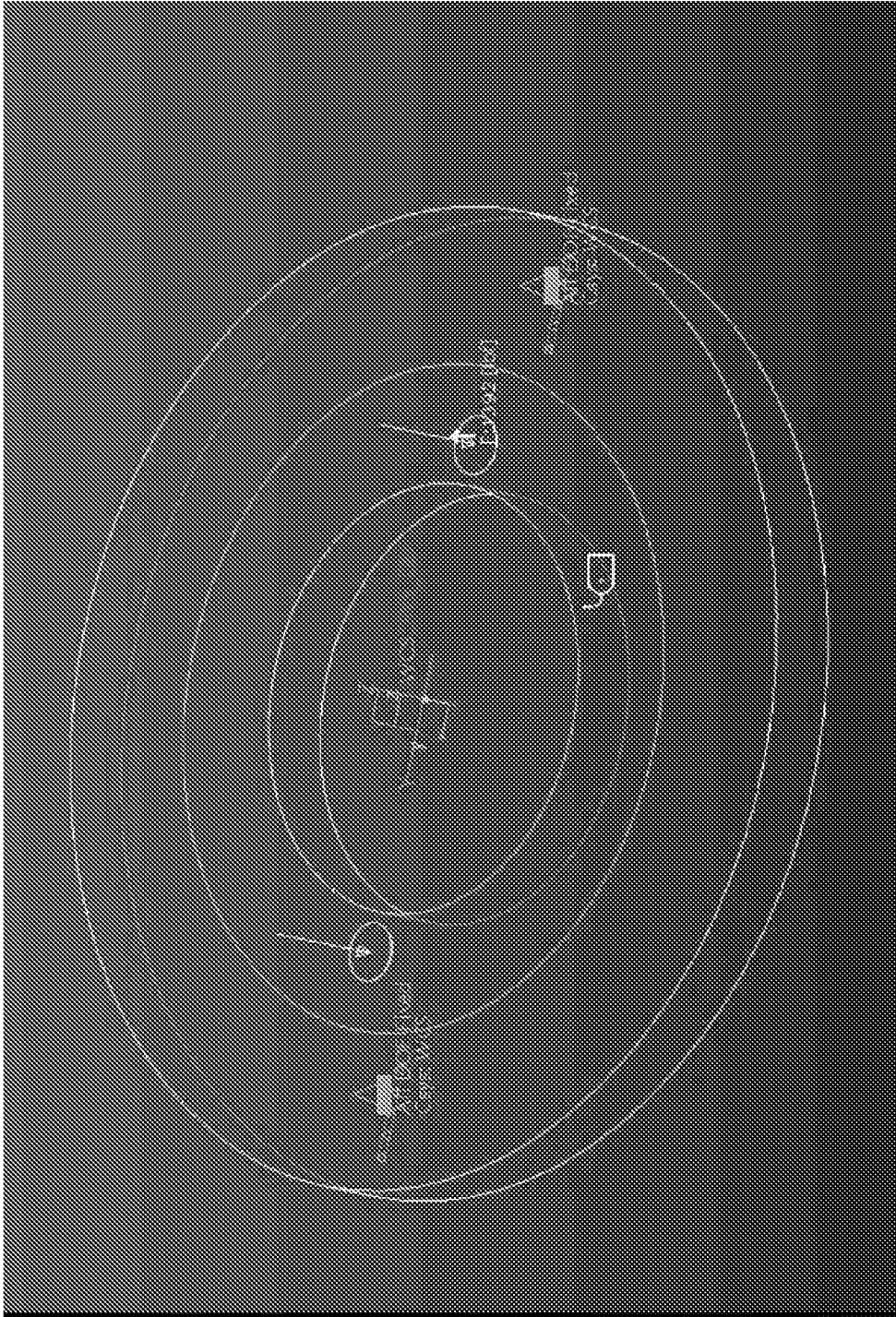

FIG. 12

200 in-lb

200 in-lb

Displacement Map (WCS)
 (in)
 Deformed
 Max Disp 0.716547e-03
 Scale 1.30216e+04
 Loadset/LoadDef : 30WACH

Stress von Mass (WCS)
 (lbf / in² in tech))
 Deformed
 Scale 1.30216e+03
 Loadset/LoadDef : 30WACH

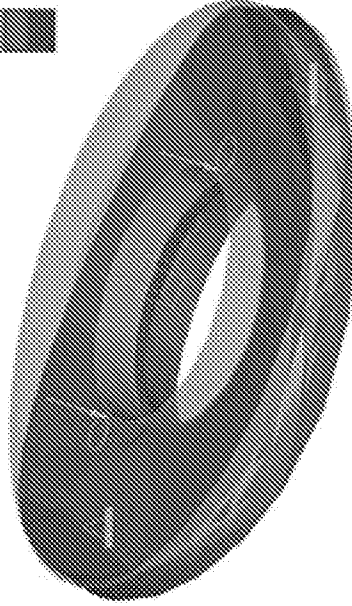
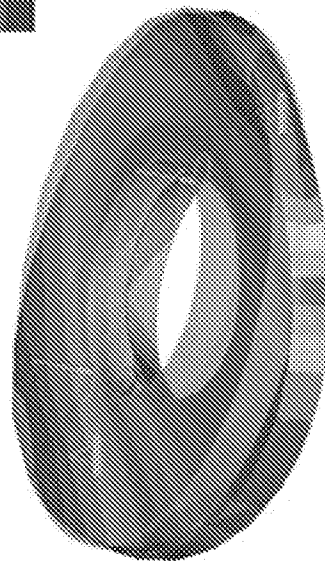
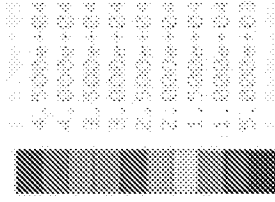
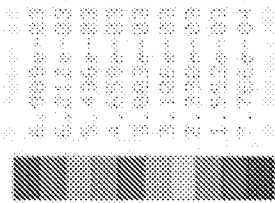

FIG. 13

FIG. 14

250 in-lb

250 in-lb

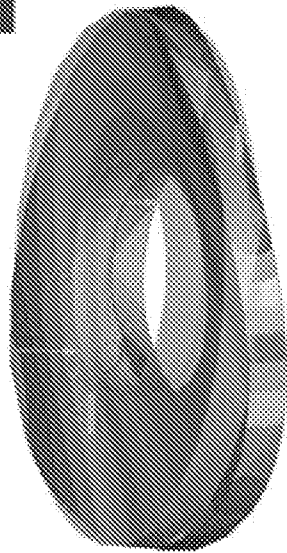
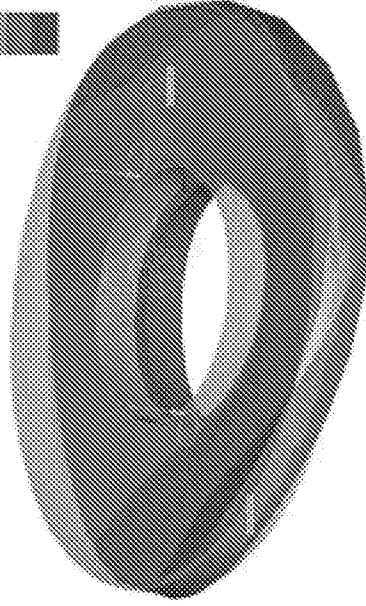
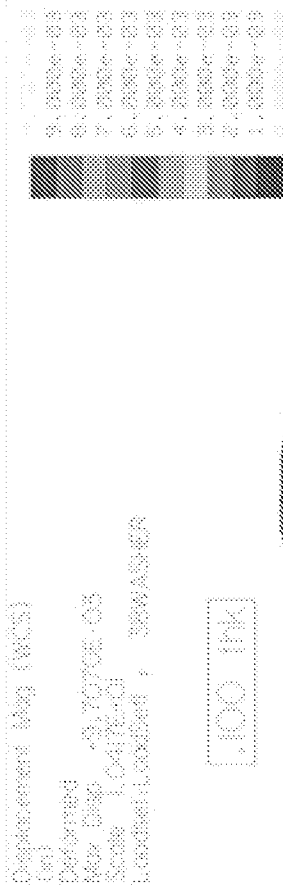
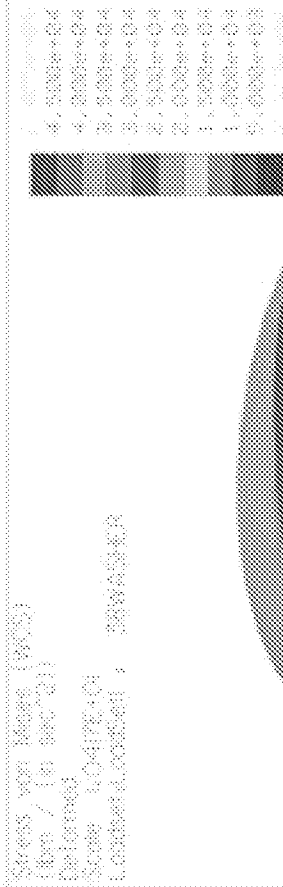
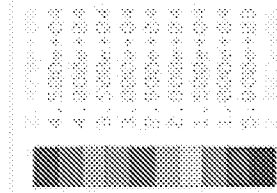

FIG. 16

FIG. 15

300 in-lb

300 in-lb



Stress von 150kg (mCS)
 Item / (in sec 2)
 Deformiert
 Speed 9.0004E+00
 Loadzeit/Loadzeit : 387A51678

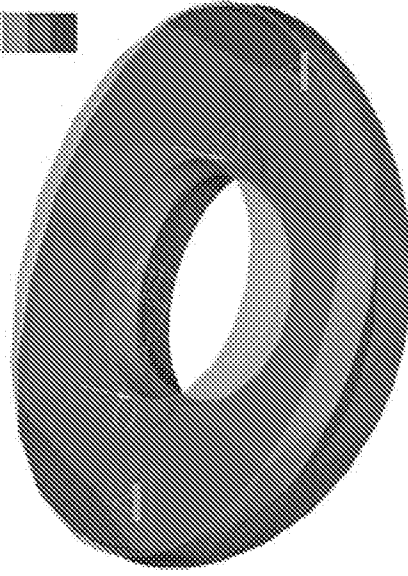
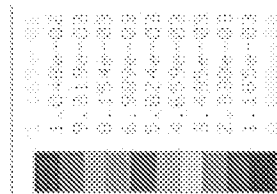

FIG. 18



Displacement Max (mCS)
 (in)
 Deformiert
 Max Disp 4.15E+02-C2
 Speed 9.0004E+00
 Loadzeit/Loadzeit : 387A51678

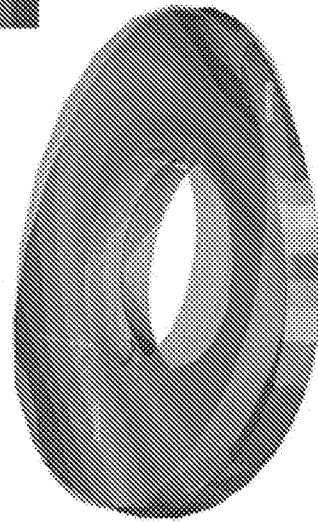

FIG. 17

CONNECTOR LOADING/BOUNDARY CONDITIONS

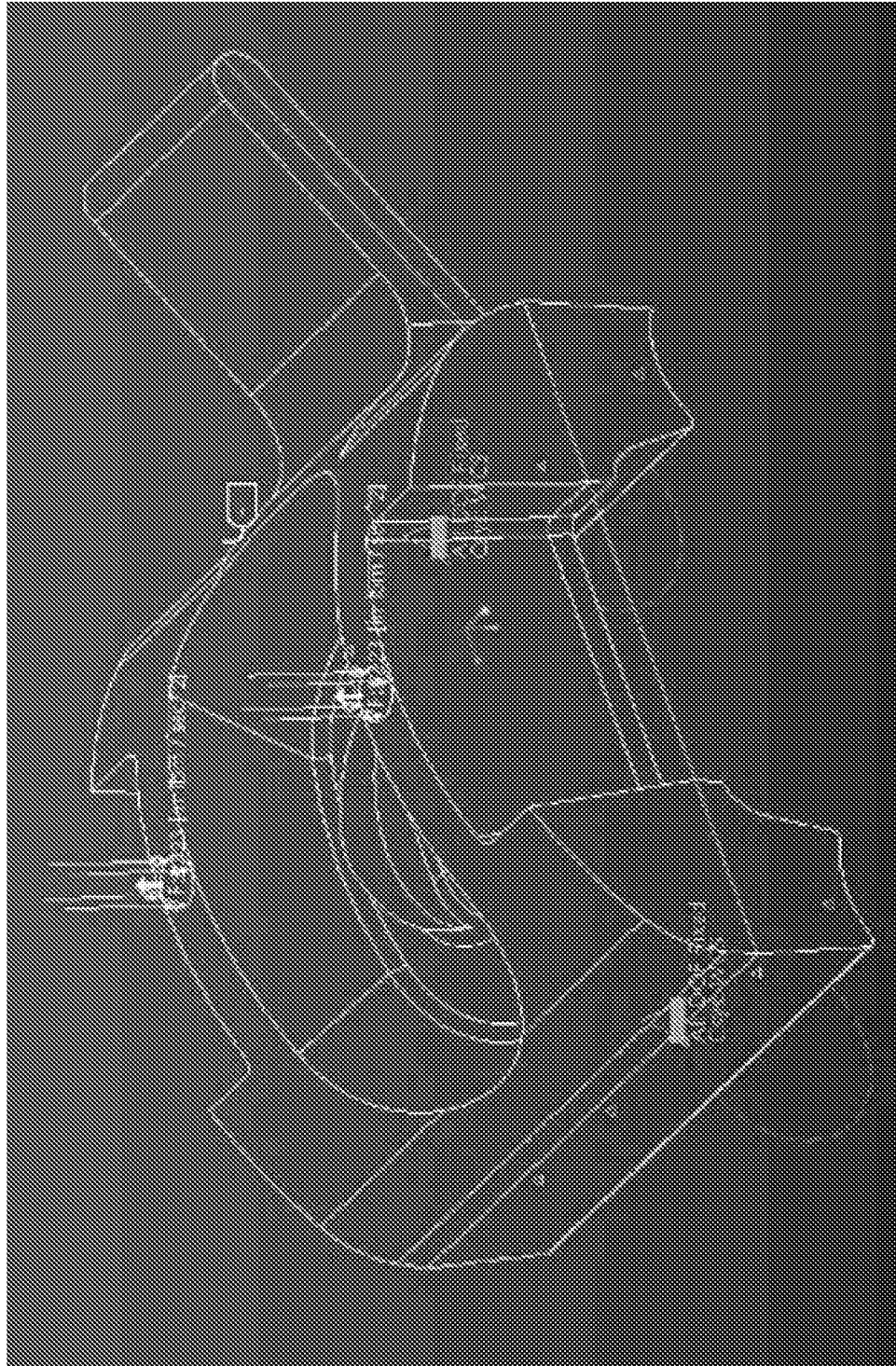

FIG. 19

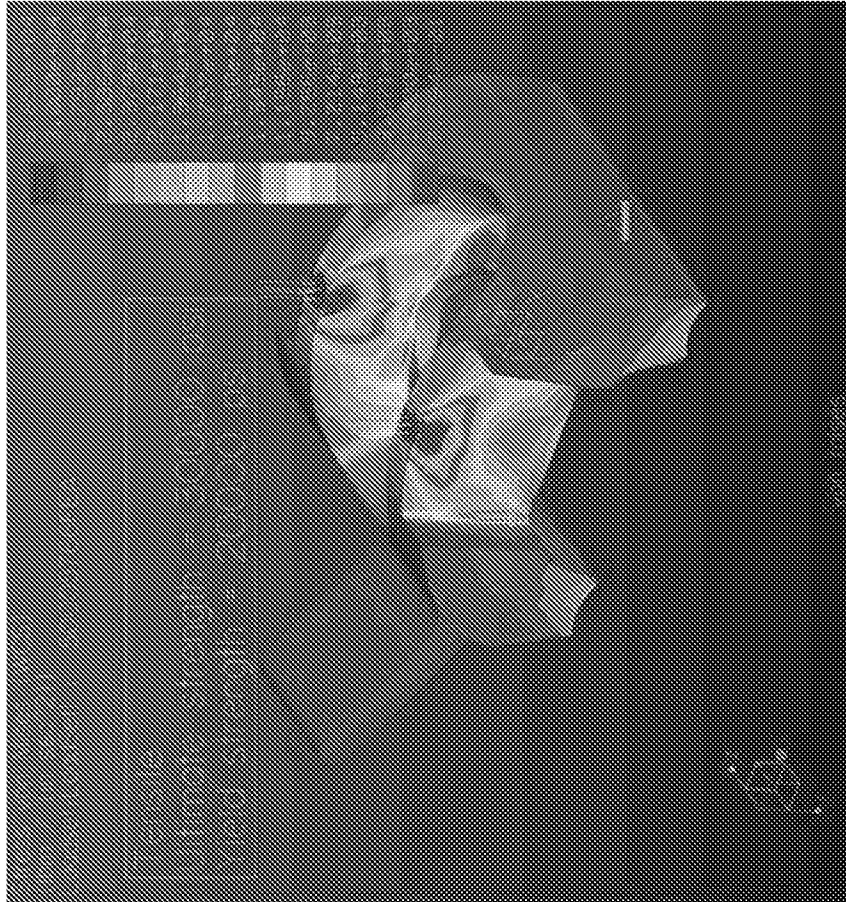

FIG. 21

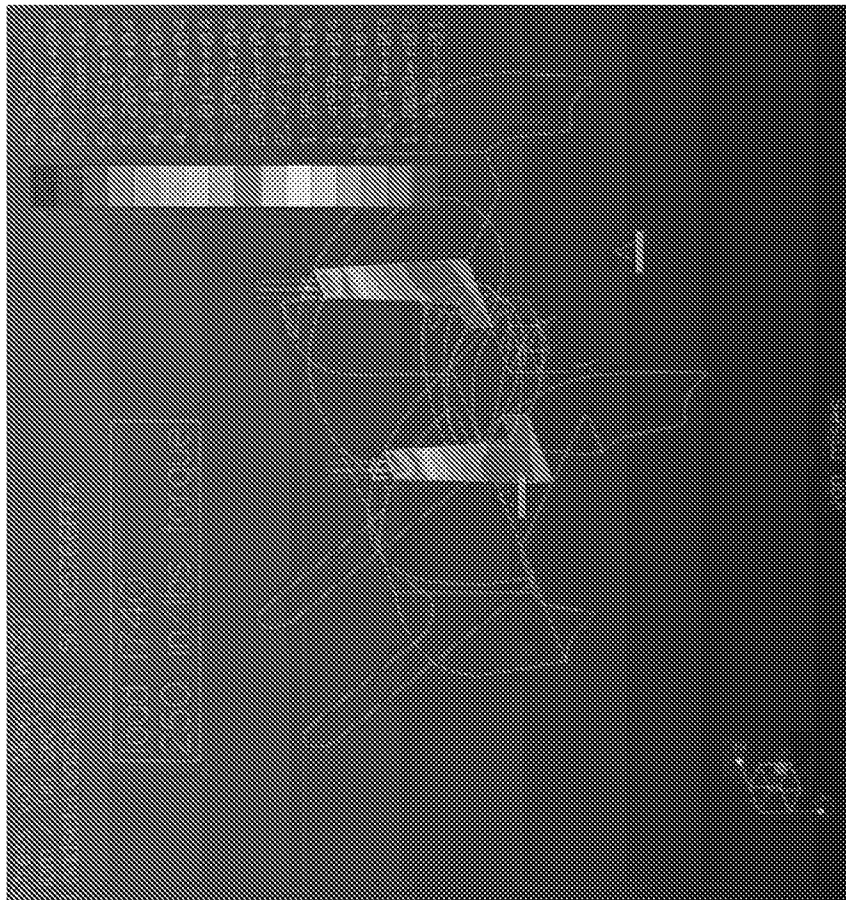

FIG. 20

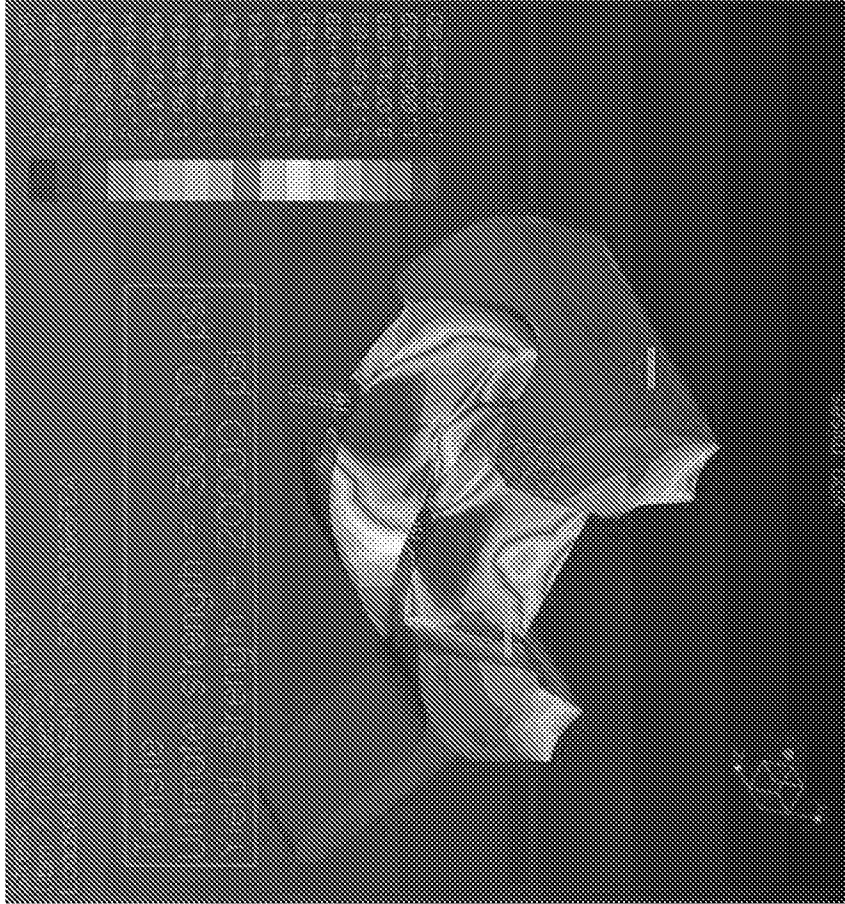

FIG. 23

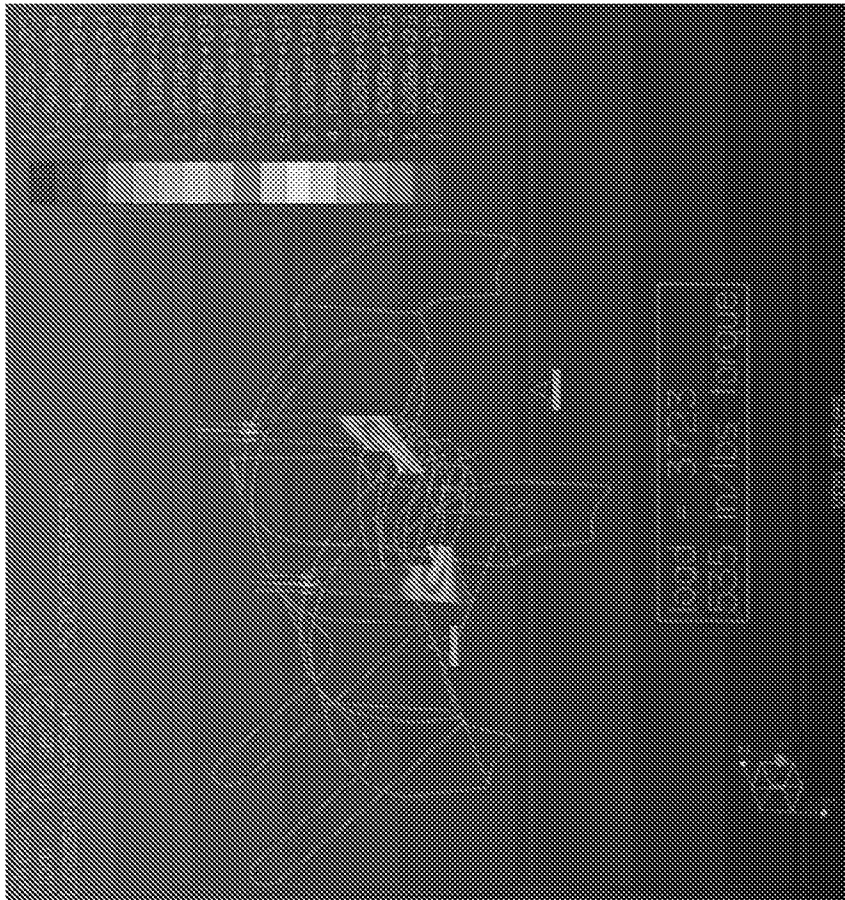

FIG. 22

15/16

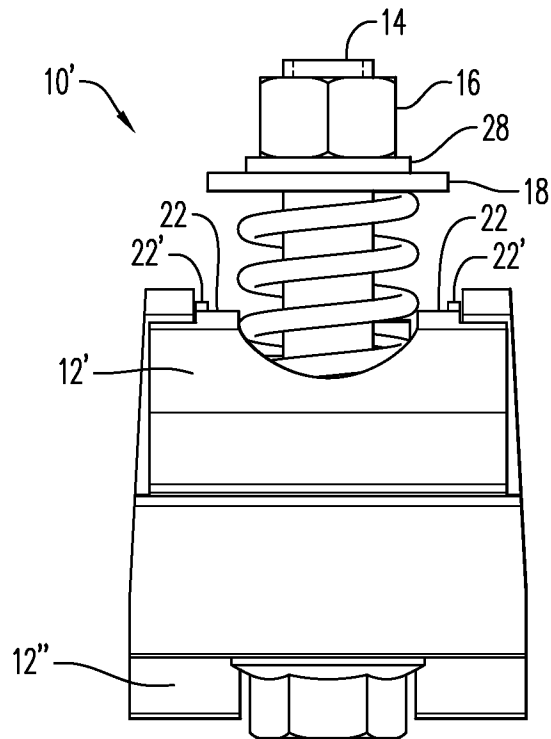

FIG. 24

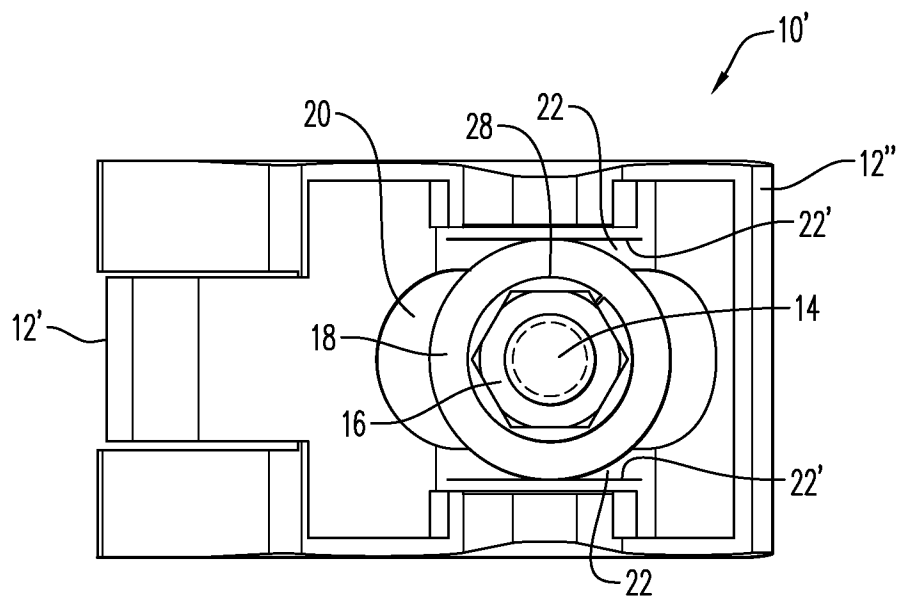

FIG. 25

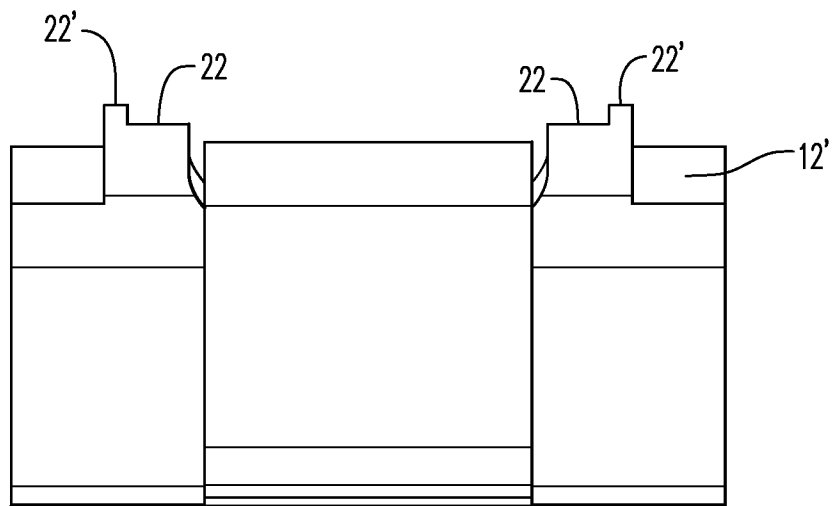

FIG. 26

INTERNATIONAL SEARCH REPORT

International application No.

PCT/US15/38137

Box No. II Observations where certain claims were found unsearchable (Continuation of item 2 of first sheet)

This international search report has not been established in respect of certain claims under Article 17(2)(a) for the following reasons:

1. Claims Nos.:
because they relate to subject matter not required to be searched by this Authority, namely:

2. Claims Nos.: 1, 5
because they relate to parts of the international application that do not comply with the prescribed requirements to such an extent that no meaningful international search can be carried out, specifically:
claims 1, 5 are unsearchable under Rule 6.2(a) because of reliance, except where absolutely necessary, on references to the description or drawings.

3. Claims Nos.:
because they are dependent claims and are not drafted in accordance with the second and third sentences of Rule 6.4(a).

Box No. III Observations where unity of invention is lacking (Continuation of item 3 of first sheet)

This International Searching Authority found multiple inventions in this international application, as follows:

-Please See Supplemental Page-

1. As all required additional search fees were timely paid by the applicant, this international search report covers all searchable claims.
2. As all searchable claims could be searched without effort justifying additional fees, this Authority did not invite payment of additional fees.
3. As only some of the required additional search fees were timely paid by the applicant, this international search report covers only those claims for which fees were paid, specifically claims Nos.:

4. No required additional search fees were timely paid by the applicant. Consequently, this international search report is restricted to the invention first mentioned in the claims; it is covered by claims Nos.:
Group I: claims 2-4;

Remark on Protest

- The additional search fees were accompanied by the applicant's protest and, where applicable, the payment of a protest fee.
- The additional search fees were accompanied by the applicant's protest but the applicable protest fee was not paid within the time limit specified in the invitation.
- No protest accompanied the payment of additional search fees.

INTERNATIONAL SEARCH REPORT

International application No.

PCT/US15/38137

A. CLASSIFICATION OF SUBJECT MATTER

IPC(8) - F16B 31/02; G01L 5/24 (2015.01)

CPC - F16B 31/025, 31/028; G01L 5/243

According to International Patent Classification (IPC) or to both national classification and IPC

B. FIELDS SEARCHED

Minimum documentation searched (classification system followed by classification symbols)

IPC(8) Classification(s): F16B 31/02; G01L 5/24 (2015.01)

CPC Classification(s): F16B 31/025, 31/028; G01L 5/243

Documentation searched other than minimum documentation to the extent that such documents are included in the fields searched

Electronic data base consulted during the international search (name of data base and, where practicable, search terms used)

PatSeer (US, EP, WO, JP, DE, GB, CN, FR, KR, ES, AU, IN, CA, INPADOC Data); Google; Google/Scholar; ProQuest; Keywords: washer, indicat*, display*, measure*, meter*, torque*, load*, moment*, force, pressur*, stress*, deflect*, deform*, strain, gap, void, spac*

C. DOCUMENTS CONSIDERED TO BE RELEVANT

Category*	Citation of document, with indication, where appropriate, of the relevant passages	Relevant to claim No.
X	US 6,204,771 B1 (CENEY S) March 20, 2001; figures 2-4; column 2, lines 47-49; column 2, lines 56-60; column 4, lines 13-21; column 7, lines 14-18	2-4
A	US 5,769,581 A (WALLACE IW et al.) June 23, 1998; entire document	2-4
A	US 4,020,734 A (BELL W) May 3, 1977; entire document	2-4
A	GB 2,217,421 A (JELFS SD) October 25, 1989; entire document	2-4

 Further documents are listed in the continuation of Box C. See patent family annex.

* Special categories of cited documents:

"A" document defining the general state of the art which is not considered to be of particular relevance

"E" earlier application or patent but published on or after the international filing date

"L" document which may throw doubts on priority claim(s) or which is cited to establish the publication date of another citation or other special reason (as specified)

"O" document referring to an oral disclosure, use, exhibition or other means

"P" document published prior to the international filing date but later than the priority date claimed

"T" later document published after the international filing date or priority date and not in conflict with the application but cited to understand the principle or theory underlying the invention

"X" document of particular relevance; the claimed invention cannot be considered novel or cannot be considered to involve an inventive step when the document is taken alone

"Y" document of particular relevance; the claimed invention cannot be considered to involve an inventive step when the document is combined with one or more other such documents, such combination being obvious to a person skilled in the art

"&" document member of the same patent family

Date of the actual completion of the international search

31 August 2015 (31.08.2015)

Date of mailing of the international search report

04 DEC 2015

Name and mailing address of the ISA/

Mail Stop PCT, Attn: ISA/US, Commissioner for Patents

P.O. Box 1450, Alexandria, Virginia 22313-1450

Facsimile No. 571-273-8300

Authorized officer

Shane Thomas

PCT Helpdesk: 571-272-4300

PCT OSP: 571-272-7774

INTERNATIONAL SEARCH REPORT
Information on patent family members

International application No.

PCT/US15/38137

-----Continued from Box No. III Observations where unity of invention is lacking-----

This application contains the following inventions or groups of inventions which are not so linked as to form a single general inventive concept under PCT Rule 13.1. In order for all inventions to be examined, the appropriate additional examination fees must be paid.

Group I: claims 2-4 are directed toward a method of using washer deflection as a torque indicator, comprising using an amount of deflection of the washer as a result of torque applied by the threaded connection as an indicator the amount of torque applied.

Group II: claims 6-8 are directed toward a torque indicating threaded mechanical fastening system.

Group III: claims 9-18 are directed toward a spring loaded pad clamp.

The inventions listed as Groups I-III do not relate to a single general inventive concept under PCT Rule 13.1 because, under PCT Rule 13.2, they lack the same or corresponding special technical features for the following reasons.

The special technical features of Group I include a method of using washer deflection as a torque indicator (which is not present in Groups II, III), comprising: providing a threaded connection having a washer; installing the threaded connection so that the washer is supported as a simple beam over a gap (which is not present in Group III); and using an amount of deflection of the washer as a result of torque applied by the threaded connection as an indicator the amount of torque applied (which is not present in Groups II, III).

The special technical features of Group II include a torque indicating threaded mechanical fastening system (which is not present in Groups I, III), comprising: a threaded connection; and a washer supported as a simple beam over a gap (which is not present in Group III) so that the threaded connection, when tightened to a predetermined torque, deflects, in bending, the washer into the gap (which is not present in Group I).

The special technical features of Group III include a spring loaded pad clamp, comprising: a deflection washer having an outer dimension; a threaded connection including a bolt and a nut; an upper pad having a gap having edges that support the outer dimension of the deflection washer, the threaded connection having a portion that passes through the deflection washer and the gap, the threaded connection having a contact region that contacts the deflection washer, the gap being larger than the contact region (which is not present in Groups I, II) so that the threaded connection, when tightened to a predetermined torque, deflects, in bending, the deflection washer into the gap (which is not present in Group I).

The common technical features of Groups I-III include providing a threaded connection having a washer; installing the threaded connection so that the washer is supported as a simple beam over a gap so that the threaded connection, when tightened to a predetermined torque, deflects, in bending, the washer into the gap.

These common technical features are disclosed by US 6,204,771 B1 (CENEY): providing a threaded connection (2; figures 2, 4) having a washer (18; figure 4); installing the threaded connection so that the washer is supported as a simple beam over a gap (washer 18 is supported over the gap between shank 4 of the bolt body and the joint 25, i.e., as a simple beam; figures 2-4) so that the threaded connection, when tightened to a predetermined torque, deflects, in bending, the washer into the gap (the amount of washer deflection is used for indicating the load on the fastener system which is a representation of torque applied; column 4, lines 13-21; column 7, lines 14-18).

Because the common technical features are disclosed by CENEY, the inventions are not so linked as to form a single general inventive concept. Therefore, Groups I-III lack unity.