



(51) International Patent Classification:

A61F 2/00 (2006.01) A61F 2/30 (2006.01)
A61F 2/02 (2006.01) A61F 2/44 (2006.01)

(21) International Application Number:

PCT/US2018/025785

(22) International Filing Date:

03 April 2018 (03.04.2018)

(25) Filing Language:

English

(26) Publication Language:

English

(30) Priority Data:

62/534,155 18 July 2017 (18.07.2017) US

(72) Inventor; and

(71) Applicant: CASTRO, Frank [US/US]; 834 Inspiration
Way, Louisville, KY 40245 (US).

(74) Agent: PEARCE, Kenneth, F.; Business Patent Law,
PLLC, 105 Franklin Court, Nicholasville, KY 40356-9045
(US).

(81) Designated States (unless otherwise indicated, for every
kind of national protection available): AE, AG, AL, AM,
AO, AT, AU, AZ, BA, BB, BG, BH, BN, BR, BW, BY, BZ,
CA, CH, CL, CN, CO, CR, CU, CZ, DE, DJ, DK, DM, DO,
DZ, EC, EE, EG, ES, FI, GB, GD, GE, GH, GM, GT, HN,
HR, HU, ID, IL, IN, IR, IS, JO, JP, KE, KG, KH, KN, KP,
KR, KW, KZ, LA, LC, LK, LR, LS, LU, LY, MA, MD, ME,
MG, MK, MN, MW, MX, MY, MZ, NA, NG, NI, NO, NZ,
OM, PA, PE, PG, PH, PL, PT, QA, RO, RS, RU, RW, SA,

SC, SD, SE, SG, SK, SL, SM, ST, SV, SY, TH, TJ, TM, TN,
TR, TT, TZ, UA, UG, US, UZ, VC, VN, ZA, ZM, ZW.

(84) Designated States (unless otherwise indicated, for every
kind of regional protection available): ARIPO (BW, GH,
GM, KE, LR, LS, MW, MZ, NA, RW, SD, SL, ST, SZ, TZ,
UG, ZM, ZW), Eurasian (AM, AZ, BY, KG, KZ, RU, TJ,
TM), European (AL, AT, BE, BG, CH, CY, CZ, DE, DK,
EE, ES, FI, FR, GB, GR, HR, HU, IE, IS, IT, LT, LU, LV,
MC, MK, MT, NL, NO, PL, PT, RO, RS, SE, SI, SK, SM,
TR), OAPI (BF, BJ, CF, CG, CI, CM, GA, GN, GQ, GW,
KM, ML, MR, NE, SN, TD, TG).

Declarations under Rule 4.17:

— of inventorship (Rule 4.17(iv))

Published:

— with international search report (Art. 21(3))

(54) Title: JOINT ARTHRODESIS SYSTEM

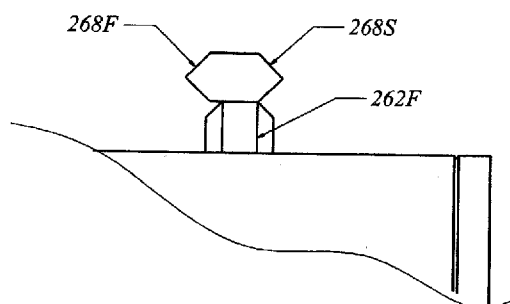

Fig 6

(57) Abstract: A joint arthrodesis system adapted for use in joint surgeries. Among other things, the joint implant has an anterior cutting edge and a rotatable cutter supported by a rotatable shaft.



Joint Arthrodesis System

Priority to US Provisional Patent Application, Serial No. 62/534,155 entitled – Joint Arthrodesis System – filed on July 18, 2017 is claimed.

BACKGROUND OF THE INVENTION

5 A. Field of the Invention

The present invention is a joint arthrodesis system. Among other things, the implant of the current system has a cutting edge as well as a rotatable cutter.

B. Description of the Previous Art

Any discussion of references cited in this Description of the Previous Art merely
10 summarizes the disclosures of the cited references and Applicant makes no admission that any cited reference or portion thereof is relevant prior art. Applicant reserves the right to challenge the accuracy, relevancy and veracity of the cited references.

1) US Patent No. 6770096-Bolger, et al. discloses an interbody spinal stabilization cage and spinal stabilization method. Among other things, Bolger does not disclose a framework
15 comprising: an anterior side comprising a cutting edge; a rotatable shaft extending between the cutting edge and the surgeon facing side; and a first arm connected with the shaft; the first arm supporting a first cutter comprising one or more blades, wherein on rotation of the shaft, the blades cut in a clockwise or counterclockwise direction.

2) US Patent No. 6824564-Crozet discloses a two-part intersomatic implant. Among
20 other things, Crozet does not disclose a framework comprising: an anterior side comprising a cutting edge; a rotatable shaft extending between the cutting edge and the surgeon facing side; and a first arm connected with the shaft; the first arm supporting a first cutter comprising one or more blades, wherein on rotation of the shaft, the blades cut in a clockwise or counterclockwise direction.

25 3) US Patent No. 6981975-Michelson discloses a method for inserting a spinal fusion implant having deployable bone engaging projections. Among other things, Michelson does not disclose a framework comprising: an anterior side comprising a cutting edge; a rotatable shaft extending between the cutting edge and the surgeon facing side; and a first arm connected with the shaft; the first arm supporting a first cutter comprising one or more blades, wherein on
30 rotation of the shaft, the blades cut in a clockwise or counterclockwise direction.

4) US Patent No. 7594932-Aferzon, et al. enables an apparatus for anterior intervertebral spinal fixation and fusion. Among other things, Aferzon does not disclose a framework comprising: an anterior side comprising a cutting edge; a rotatable shaft extending between the cutting edge and the surgeon facing side; and a first arm connected with the shaft; the first arm supporting a

first cutter comprising one or more blades, wherein on rotation of the shaft, the blades cut in a clockwise or counterclockwise direction.

5) US Patent No. 8366774-Bruffey, et al. discloses an apparatus for anterior intervertebral spinal fixation and fusion. Among other things, Bruffey does not disclose a framework comprising:
5 an anterior side comprising a cutting edge; a rotatable shaft extending between the cutting edge and the surgeon facing side; and a first arm connected with the shaft; the first arm supporting a first cutter comprising one or more blades, wherein on rotation of the shaft, the blades cut in a clockwise or counterclockwise direction.

6) US Patent No. 8382843-Laurence, et al. discloses an intervertebral implant with blades
10 for connecting to adjacent vertebral bodies. Among other things, Laurence does not disclose a framework comprising: an anterior side comprising a cutting edge; a rotatable shaft extending between the cutting edge and the surgeon facing side; and a first arm connected with the shaft; the first arm supporting a first cutter comprising one or more blades, wherein on rotation of the shaft, the blades cut in a clockwise or counterclockwise direction.

7) US Patent No. 9539110-Bergey discloses an interbody prosthetic device with
15 compound-arc, blade anchor. Among other things, Bergey does not disclose a framework comprising: an anterior side comprising a cutting edge; a rotatable shaft extending between the cutting edge and the surgeon facing side; and a first arm connected with the shaft; the first arm supporting a first cutter comprising one or more blades, wherein on rotation of the shaft, the
20 blades cut in a clockwise or counterclockwise direction.

8) US Published Patent Application No. 20070270961-Ferguson discloses a spinal
implant deployable with retractable barbs. Among other things, Ferguson does not disclose a framework comprising: an anterior side comprising a cutting edge; a rotatable shaft extending
25 between the cutting edge and the surgeon facing side; and a first arm connected with the shaft; the first arm supporting a first cutter comprising one or more blades, wherein on rotation of the shaft, the blades cut in a clockwise or counterclockwise direction.

9) US Published Patent Application No. 20080027550-Link, et al. discloses a cervical
intervertebral disc prosthesis comprising an anti-dislocation device and instruments. Among other things, Link does not disclose a framework comprising: an anterior side comprising a cutting
30 edge; a rotatable shaft extending between the cutting edge and the surgeon facing side; and a first arm connected with the shaft; the first arm supporting a first cutter comprising one or more blades, wherein on rotation of the shaft, the blades cut in a clockwise or counterclockwise direction.

10) US Published Patent Application No. 20140121773-Patel, et al. discloses a stand-alone
35 interbody fixation system. Among other things, Patel does not disclose a framework comprising: an

anterior side comprising a cutting edge; a rotatable shaft extending between the cutting edge and the surgeon facing side; and a first arm connected with the shaft; the first arm supporting a first cutter comprising one or more blades, wherein on rotation of the shaft, the blades cut in a clockwise or counterclockwise direction.

5 11) US Published Patent Application No. 20160374831-Duffield, et al. discloses an interbody fusion device and system for implantation. Among other things, Duffield does not disclose a framework comprising: an anterior side comprising a cutting edge; a rotatable shaft extending between the cutting edge and the surgeon facing side; and a first arm connected with the shaft; the first arm supporting a first cutter comprising one or more blades, wherein on rotation of the
10 shaft, the blades cut in a clockwise or counterclockwise direction.

 12) WIPO Published Patent Application No. 2007/079021-Aferzon, et al. discloses an apparatus for anterior intervertebral spinal fixation and fusion. The Specification of WIPO Published Patent Application No. 2007/079021-Aferzon, et al. is similar to US Patent No. 7594932-Aferzon, et al. Therefore, among other things, Aferzon does not disclose a framework comprising: an anterior
15 side comprising a cutting edge; a rotatable shaft extending between the cutting edge and the surgeon facing side; and a first arm connected with the shaft; the first arm supporting a first cutter comprising one or more blades, wherein on rotation of the shaft, the blades cut in a clockwise or counterclockwise direction.

SUMMARY OF THE INVENTION

20 The more tools or instruments inserted into a surgical field, the greater the possibility of an error or patient injury may occur. Due to the simplicity of the current joint arthrodesis system, a number of surgical tools required and steps associated with performing prior state-of-the-art fusions can be eliminated. The arthrodesis procedures, among other uses, can be performed in the cervical spine, sacroiliac joint, ankle, hand or other similar joints.

25 One of the currently available state-of-the art techniques for cervical fusions is the DTRAX system. The DTRAX spinal system uses five instruments, a working cannula, and numerous steps. A working cannula with a chisel is used to breach the desired posterior facet joint. Once in position, the chisel is removed and a broach is inserted through the working cannula. The broach is advanced and retracted several times in order to remove the
30 cartilaginous end-plates. After the broach is removed from the working cannula, a drill is inserted. After drilling is completed, a second rasp is placed to decorticate the posterior cortex. After the use of the second rasp is completed, the fixation device (filled with graft material) is inserted through the working cannula into the joint. Additional graft material is then impacted behind the implant.

Current state-of-the-art sacroiliac surgical procedures require a fusion device that is either inserted from a posterior or lateral approach. Applicant's understanding is: there are fusion devices for use with either the posterior approach or the lateral approach, but the same fusion device is incapable for use with both the posterior and the lateral approaches. Many of the current sacroiliac fusion procedures require the use of working cannulas, numerous broaches, rasps, drills and other devices that tend to complicate the surgical procedure. Applicant's current joint arthrodesis system can accomplish sacroiliac fusions through either a posterior or lateral approach with fewer surgical tools and steps.

Unlike other joint arthrodesis systems, the present system's joint arthrodesis implant includes a cutting edge and one or more rotatable cutters including one or more blades. Among other things, it is believed that the cutters can assist with the postoperative stabilization of the joint implant. In accordance with the current invention, rotation of a blade about 90 degrees allows the blade to extend beyond the joint implant's framework and penetrate adjacent cartilage and bone.

An aspect of the present invention is to provide a joint implant with an anterior side having a cutting edge.

Still another aspect of the present invention is to provide a joint implant with a rotatable shaft extending from the surgeon facing side having to anterior side.

It is still another aspect of the present invention to provide a joint implant with one or more rotatable cutters affixed to the shaft, where each cutter can include one or more blades.

Yet still another aspect of the present invention is to provide a joint implant where rotation of the rotatable cutter causes one or more of the cutters to extend beyond the framework.

Still another aspect of the present invention is to provide a joint implant with rotatable cutters for cutting in the clockwise or counterclockwise directions.

Yet another aspect of the present invention is to provide a joint implant with one or more recesses capable of receiving one or more cutters, for example, when the implant is utilized in its insertion mode.

It is still another aspect of the present invention to provide a joint implant where near the completion of the surgical procedure, the joint implant's rotating blades can be rotated to extend beyond the joint implant's framework.

Still another aspect of the present invention is to provide edges on the cutting arms that can assist with the morselization of bone.

A preferred embodiment of the current invention can be described as: a joint arthrodesis system comprising: a) a framework comprising: i) a longitudinal axis, openings

outward from the longitudinal axis and a length greater than a width; ii) an anterior side comprising a cutting edge integral with the anterior side; iii) a surgeon facing side at an end opposite the anterior side; the anterior side having a lesser cross-sectional area than a cross-sectional area of the surgeon facing side, wherein the cross-sectional areas are determined perpendicular to the longitudinal axis; iv) a plate seated within the cross-sectional area of the surgeon facing side and affixed to the framework, wherein the plate is perpendicular to the longitudinal axis and comprises one or more apertures capable of reciprocating with one or more instruments; v) a shaft aligned with the longitudinal axis and extending between an inner side of the plate and the cutting edge; and vi) arms connected with the shaft; the arms supporting cutters comprising one or more blades, wherein on rotation of the shaft, the one or more blades cut in a clockwise or counterclockwise direction; and b) a tool capable of rotating the shaft.

Another preferred embodiment of the current invention can be described as: a joint implant comprising: a) a framework comprising: i) a longitudinal axis, openings outward from the longitudinal axis and a length greater than a width; ii) an anterior side comprising a cutting edge; iii) a surgeon facing side at an end opposite the anterior side, wherein the surgeon facing side is perpendicular to the longitudinal axis and comprises one or more apertures capable of reciprocating with one or more instruments; iv) a shaft aligned with the longitudinal axis and extending between an inner side of the surgeon facing side and the cutting edge; and v) one or more arms connected with the shaft; the one or more arms supporting one or more cutters comprising one or more blades, wherein on rotation of the shaft, one or more blades cut in a clockwise or counterclockwise direction.

Still another preferred embodiment of the current invention can be described as: a joint implant comprising: a) a framework comprising: i) a longitudinal axis and openings outward from the longitudinal axis; ii) an anterior side comprising a cutting edge; iii) a surgeon facing side at an end opposite the anterior side; the surgeon facing side comprising one or more apertures; iv) a rotatable shaft extending between the cutting edge and the surgeon facing side; and v) a first arm connected with the shaft; the first arm supporting a first cutter comprising one or more blades, wherein on rotation of the shaft, the blades cut in a clockwise or counterclockwise direction.

It is the novel and unique interaction of these simple elements which creates the system within the ambit of the present invention. Pursuant to the Articles of the Patent Cooperation Treaty, select preferred embodiments of the current invention follow. However, it is to be understood that the descriptions of the preferred embodiments do not limit the scope of the present invention.

BRIEF DESCRIPTION OF THE DRAWINGS

FIG. 1 is a perspective of a preferred embodiment of the joint implant (100) utilized in the present system.

FIG. 2 is a frontal view of plate (210) seated in cross-sectional area (120) of surgeon facing side (104) of implant (100).

FIG. 3 is a top view of implant (100).

FIG. 4 is a frontal view cross-section of implant (100) along section A-A as seen from the posterior side (104).

FIG. 5 is a perspective of implant (100).

FIG. 6 is a frontal view of a preferred embodiment of cutter (260F) shown in FIG. 5 as seen from the anterior side of implant (100).

FIG. 7 is a perspective of cutting edge (300) of implant (100).

FIG. 8 is a lateral view as seen from side (108B) with lateral sides (108A-D) of implant (100) cut away.

FIG. 9 is a perspective of a preferred embodiment of implant (100).

FIG. 10 is a perspective of a preferred embodiment of implant (100).

FIG. 11 is a perspective of a preferred embodiment of implant (100) where cutters (260F, 260S) are capable of being rotated 360 degrees about longitudinal axis X-X.

FIG. 12 is another perspective of a preferred embodiment of implant (100) where cutters (260F, 260S) are capable of being rotated 360 degrees about longitudinal axis X-X.

DESCRIPTION OF THE PREFERRED EMBODIMENTS

Although the disclosure hereof is detailed to enable those skilled in the art to practice the invention, the embodiments published herein merely exemplify the present invention.

As used herein, with respect to the joint arthrodesis system's implant: 1) "anterior" of the joint implant means the side of the implant most distant from the surgeon and 2) "posterior or surgeon-facing side" of the joint implant means the side of the implant nearest the surgeon.

In the most general sense, the present invention is a joint arthrodesis system where an implant is surgically inserted into a joint space. The current implant can be useful for surgeries that can assist in stabilizing injured, deformed and or degenerative joints. Preferred embodiments of the current invention can be employed with ankle, cervical, hand, sacroiliac or other orthopaedic procedures. It appears that the present system is particularly useful for posterior cervical fusions and sacroiliac joint fusions. However, the current invention can also be used to fuse the tibia to the talus, the talus to the calcaneus, and metacarpals to the phalanges.

Preferred embodiments of the current joint implants can be manufactured of titanium alloys, stainless steel, resorbable polymers, non-resorbable polymers or any other composition acceptable in the art. Meeting a long felt but unfilled need in the orthopaedic surgical arts, the novel and unique structures of the present combinations allow the surgical team to, among
5 other things, simplify previous procedures.

The present invention has a cutting edge and a rotatable cutter including one or more blades. The cutting edge of the implant's framework is capable of dissecting through adipose, muscle and/or joint capsule tissues. The rotatable cutter of the implant is capable of cutting cartilage and bone and can be associated with the creation of the surgical cavity. Further, the
10 rotatable cutter can morselize bone in preparation for fusion. The combination of the cutting edge(s) and rotatable cutter of the current joint implant system meet long felt but unfilled needs in the orthopedic surgical arts: among other things, these novel and unique structures allow the surgeon to simplify the previous operating procedures utilized for posterior cervical, sacroiliac, and other joint fusions.

15 Devices that insert osteogenic and/or other substances into the interior volume of the implant can be used with the present invention. The current joint arthrodesis system is also compatible with flexible drills, fiber optics, vacuums, one or more cannulas and one or more devices for inserting the joint implant. Combinations of one or more of the before identified ancillary devices and the current joint arthrodesis system can assist with the creation and
20 healing of the surgical wound.

Openings of the current joint implant increase the probability of the osteogenic materials and/or arthrodesis accelerating substances procuring a blood supply. And it is believed that increasing the blood supply to the osteogenic materials held by the joint implant or implant increases the probability of successful fusion. Introduction of osteogenic and other
25 substances into the implant can hasten the healing of the surgical wound.

FIG. 1 is a perspective of a preferred embodiment of the joint implant (100) utilized in the present system. Joint implant or implant (100) has a framework that includes an anterior side (102), surgeon facing or posterior side (104) and a plurality of lengthwise sides (108A-D) extending between anterior side (102) and surgeon facing or posterior side (104). Lengthwise
30 sides (108A, 108C) are provided with opening (110) that, among other things, allows the implant's blades to rotate. When surgical parameters require, osteogenic and/or other substances can also be placed into the internal volume of implant (100).

With respect to this application, the longitudinal axis of joint implant (100) is measured along axis X-X. Axis X-X can correspond with shaft (240) or in some preferred embodiments shaft (240) can be offset from axis X-X. Width of implant (100) is measured along axis Y-Y
35

or an axis parallel to axis Y-Y shown in FIG. 1. Height of joint implant is measured along axis Z-Z or an axis parallel to axis Z-Z of the joint implant's framework.

Within the scope of the current invention, select embodiments of implant (100) have a length greater than a width. In select preferred embodiments, the width of implant (100) is greater than the height of implant (100). In other preferred embodiments of implant (100), the height of implant (100) is greater than the width of implant (100). The inward sides of anterior side (102), posterior side (104) and lengthwise sides (108A-D) facing longitudinal axis X-X create an available inner volume of implant (100) which can receive osteogenic as well as other substances.

Lengthwise or lateral sides (108A-108D) are positioned outward from joint implant's (100) longitudinal axis X-X. Select preferred embodiments of implant (100) are provided with a cross-section distant from anterior side (102) that has a greater cross-sectional area than the anterior side (102). As disclosed herein, cross-sections are determined perpendicular to the longitudinal axis X-X of the implant's framework. Anterior side (102) of implant (100) is provided with cutting edge (300) as will be more specifically enabled below. In some preferred embodiments, cutting edge (300) can be integral with anterior side (102) of joint implant (100). Attached to shaft (240) are arms (262F, 262S) supporting cutters (260F, 260S). Although as shown in FIG. 1, cutters (260F, 260S) are supported by two arms (262F, 262S), in select preferred embodiments, cutters (260F, 260S) can be supported by a single arm (262F, 262S). Additionally, some preferred embodiments of cutters (260F, 260S) can be provided with one or more sharp edges (264F, 264S) that can assist cutters (260F, 260S) with the morselization of bone.

Posterior side (104) of implant (100) includes cross-sectional area (120). Preferred embodiments of joint implant (100) are provided with plate (210) where at least a portion the plate (210) is perpendicular to longitudinal axis X-X. Plate (210) is seated within cross-sectional area (120) of surgeon facing side (104) and affixed to implant (100). Preferred embodiments of plate (210) are provided with one or more apertures (220) that can be utilized with one or more tools associated with the surgery.

FIG. 2 is a frontal view of plate (210) seated in cross-sectional area (120) of surgeon facing side (104) of implant (100). As shown, cross-sectional area is provided with a plurality of openings (220).

FIG. 3 is a top view of implant (100), where implant is shown in its subcutaneous surgical wound creation mode. Shaft (240) is connected with anterior end (102) and surgeon posterior side (104) in any manner acceptable in the art. Proximate shaft (240) is opening (110) and lateral sides (108A-108D). First arms (262F) attach first cutter (260F) to shaft (240).

Second arms (262S) attach second cutter (260S) to shaft (240). Cutters (260F and 260S) can be provided with blades that cut in both the clockwise and counterclockwise directions when shaft (240) is rotated. Lateral side (108B) is provided with recess (266F) capable of receiving cutter (260F). Lateral side (108D) is provided with recess (266S) capable of receiving cutter (260S).
5 As shown in FIG. 3, recess (266F) is located on the superior side of lengthwise side (108B) and recess (266S) is positioned on the inferior side of lengthwise side (108D).

FIG. 4 is a frontal view cross-section of implant (100) along section A-A as seen from the posterior side (104). Cutter (260F) is received in recess (266F) of lateral side (108B) and arms (262F) attach cutter (260F) to shaft (240). Cutter (260S) is received in recess (266S) of
10 lateral side (108D) and arms (262S) attach cutter (260S) to shaft (240). Within the scope of the current invention, cutters (260F, 260S) can be supported by a single arm (262F, 262S). And when surgical parameters require, implant (100) is engineered with only a single cutter (260F).

FIG. 5 is a perspective of a preferred embodiment of implant (100). Shaft (240) extends from cutting edge (300) toward surgeon facing side (104) of implant (100). As shown
15 in FIG. 5, shaft (240) has rotatable arms (262F, 262S) carrying cutters (260F, 260S) such that rotation of shaft (240) extends cutter (260F) beyond lateral side (108C) and cutter (260S) beyond lateral side (108A) of implant (100).

FIG. 6 is a frontal view of a preferred embodiment of cutter (260F) shown in FIG. 5 as seen from the anterior side of implant (100). Cutter (260F) is provided with first and second
20 cutting blades (268F, 268S) that allow cutter (260F) to cut in both the clockwise and counterclockwise directions. Depending on engineering parameters cutters (260F, 260S) can be equipped with one or more cutting blades. Along with the cutting function of cutters (260F, 260S), near the conclusion of the surgical procedure, cutting blades (268F, 268S) can be rotated to cut into bone so that cutters (260F, 260S) further anchor the implant (100) within the
25 joint space.

FIG. 7 is a perspective of cutting edge (300) of implant (100). Cutting edge (300) can be integral with implant (100) or cutting edge (300) can be manufactured as an interchangeable fitting for implant (100). Within the ambit of the current joint arthrodesis system, cutting edges (300) are capable of dissecting through adipose, muscle and/or joint capsule tissues.

FIG. 8 is a lateral view as seen from side (108B) with lateral sides (108A-D) of implant (100) cut away. Plate (210) includes aperture (220) capable of receiving hand tool (360). Hand tool (360) includes handle (362) and stem (364) that extends from handle (362). Shaft (240) includes receptacle (244) for reciprocating with stem (364) of hand tool (360). Interaction
30 between stem (364) and receptacle (244) allows hand tool (360) to rotate cutters (260F, 260S) in both clockwise and counterclockwise directions. In select preferred embodiments receptacle
35

(244) can extend the entire length of (240) for allowing ingress and egress of surgical appliances and instruments from the surgical field, e.g., wires, cannulas, vacuum tubes, fiber optics, etc.

FIG. 9 is a perspective of a preferred embodiment of implant (100) that depicts cutting edge (300), rotatable cutters (260F, 260S) and opening (110) of implant (100). As shown, 5
barbs (280) extend away from surfaces of lengthwise sides (108B, 108C, 108D). It is believed that barbs (280) can assist in deterring movement of implant (100) within the joint space.

FIG. 10 is a perspective of a preferred embodiment of implant (100) that depicts cutting edge (300), rotatable cutters (260F, 260S) and opening (110) of implant (100). In the FIG. 10 10
embodiment, surfaces of lengthwise sides (108B, 108C, 108D) are provided with micropores (290) of various volumes. It is believed that surface micropores (290) can assist with long term fixation of the implant by allowing more bone ingrowth into the implant. In accordance with the FIG. 10 preferred embodiment of spinal implant (100), micropores (290) are generated by surface treatments to at least a portion of surfaces of lengthwise sides (108B, 108C, 108D).
15 Micropores (290) can be created by abrasive, chemical or laser means.

FIG. 11 is a perspective of a preferred embodiment of implant (100) where cutters (260F, 260S) are capable of being rotated 360 degrees about longitudinal axis X-X.

FIG. 12 is another perspective of a preferred embodiment of implant (100) where cutters (260F, 260S) are capable of being rotated 360 degrees about longitudinal axis X-X.

20 As measured along longitudinal axis X-X of implant's (100) framework, preferred embodiments are provided with cutting edge (300) that can be up to about 3 millimeters in length. The length of implant (100), including cutting edge (300) can be from about 50 millimeters to about 6 millimeters. Cross-sectional widths of cutting edge (300) can range from about 2 millimeters² to about 18 millimeters². Cross-sectional widths of implant (100),
25 other than cutting edge (300) can range from about 8 millimeters² to about 45 millimeters².

Pursuant to the Articles of the Patent Cooperation Treaty, preferred embodiments of the current system invention have been disclosed and enabled.

WHAT IS CLAIMED IS:

- 1) A joint arthrodesis system comprising:
 - a) a framework (100) comprising:
 - i) a longitudinal axis, openings (110) outward from said longitudinal axis and a length greater than a width;
 - ii) an anterior side (102) comprising a cutting edge (300) integral with said anterior side (102);
 - iii) a surgeon facing side (104) at an end opposite said anterior side (102); said anterior side (102) having a lesser cross-sectional area than a cross-sectional area of said surgeon facing side (104), wherein said cross-sectional areas are determined perpendicular to said longitudinal axis;
 - iv) a plate (210) seated within said cross-sectional area of said surgeon facing side (104) and affixed to said framework (100), wherein said plate (210) is perpendicular to said longitudinal axis and comprises one or more apertures (220) capable of reciprocating with one or more instruments;
 - v) a shaft (240) aligned with said longitudinal axis and extending between an inner side of said plate (210) and said cutting edge (300); and
 - vi) arms (262F, 262S) connected with said shaft (240); said arms (262F, 262S) supporting cutters (260F, 260S) comprising one or more blades (268F, 268S), wherein on rotation of said shaft (240), said one or more blades (268F, 268S) rotate in a clockwise or counterclockwise direction; and
 - b) a tool (360) capable of rotating said shaft (240).
- 2) The joint arthrodesis system of claim 1, wherein said framework (100) comprises four lateral sides (108A-108D).
- 3) The joint arthrodesis system of claim 2, wherein one or more surfaces of said framework (100) comprises barbs (280) and/or micropores (290).
- 4) The joint arthrodesis system of claim 3, wherein said framework (100) comprises recesses (266F, 266S) adapted to receive said cutters (260F, 260S), said recesses (266F, 266S) positioned diagonally from each other relative to two opposed lateral sides (108A, 108D) said framework.
- 5) The joint arthrodesis system of claim 4, wherein outermost ends of said blades (268F, 268S) extend to outward edges of said recesses (266F, 266S).
- 6) A joint implant comprising:
 - a) a framework (100) comprising:

- i) a longitudinal axis, openings (110) outward from said longitudinal axis and a length greater than a width;
- ii) an anterior side (102) comprising a cutting edge (300);
- iii) a surgeon facing side (104) at an end opposite said anterior side (102), wherein said surgeon facing side (104) is perpendicular to said longitudinal axis and comprises one or more apertures (220) capable of reciprocating with one or more instruments;
- iv) a shaft (240) aligned with said longitudinal axis and extending between an inner side of said facing side (104) and said cutting edge (300); and
- v) one or more arms (262F, 262S) connected with said shaft (240); said one or more arms (262F, 262S) supporting one or more cutters (260F, 260S) comprising one or more blades (268F, 268S), wherein on rotation of said shaft (240), said one or more blades (268F, 268S) rotate in a clockwise or counterclockwise direction.
- 7) The joint implant of claim 6: said framework (100) comprising four lateral sides (108A-108D).
- 8) The joint implant of claim 7: said shaft (240) comprising a receptacle (244) for interacting with a tool (360) capable of rotating said shaft (240).
- 9) The joint implant of claim 8, wherein said one or more arms (262F, 262S) comprise one or more sharp edges (264F, 264S) adapted to morselize bone.
- 10) The joint implant of claim 8, wherein one or more surfaces of said framework (100) comprises barbs (280) and/or micropores (290).
- 11) The joint implant of claim 8: said framework (100) comprising recesses (266F, 266S) adapted to receive said cutters (260F, 260S), said recesses (266F, 266S) positioned diagonally from each other relative to two opposed lateral sides said framework (100).
- 12) The joint implant of claim 11, wherein said anterior side (102) has a lesser cross-sectional area than a cross-sectional area of said surgeon facing side (104); said cross-sectional areas determined perpendicular to said longitudinal axis.
- 13) A joint implant comprising:
- a) a framework (100) comprising:
- i) a longitudinal axis and openings (110) outward from said longitudinal axis;
- ii) an anterior side (102) comprising a cutting edge (300);
- iii) a surgeon facing side (104) at an end opposite said anterior side (102); said surgeon facing side (104) comprising one or more apertures (220);

iv) a rotatable shaft (240) extending between said cutting edge (300) and said surgeon facing side (104); and

v) a first arm (262F) connected with said shaft (240); said first arm (262F) supporting a first cutter (260F) comprising one or more blades (268F, 268S),
5 wherein on rotation of said shaft (240), said blades (268F, 268S) rotate in a clockwise or counterclockwise direction.

14) The joint implant of claim 13: said framework (100) comprising four lateral sides (108A-108D) and a length greater than a width.

15) The joint implant of claim 14: said shaft (240) comprising a receptacle (244) for
10 interacting with a tool (360) capable of rotating said shaft (240).

16) The joint implant of claim 14, wherein one or more surfaces of said framework (100) comprises barbs (280) and/or micropores (290).

17) The joint implant of claim 15, wherein said first arm (262F) comprises one or more sharp edges (264F, 264S) adapted to morselize bone.

18) The joint implant of claim 15: said framework (100) further comprising a
15 second arm (262S) connected with said shaft (240); said second arm (262S) supporting a second cutter (260S) comprising one or more blades (268F, 268S), wherein on rotation of said shaft (240), said blades (268F, 268S) rotate in a clockwise or counterclockwise direction.

19) The joint implant of claim 18: said framework's anterior side (102) having a
20 lesser cross-sectional area than a cross-sectional area of said surgeon facing side (104).

20) The joint implant of claim 19: said framework (100) comprising recesses (266F, 266S) adapted to receive said cutters (260F, 260S).

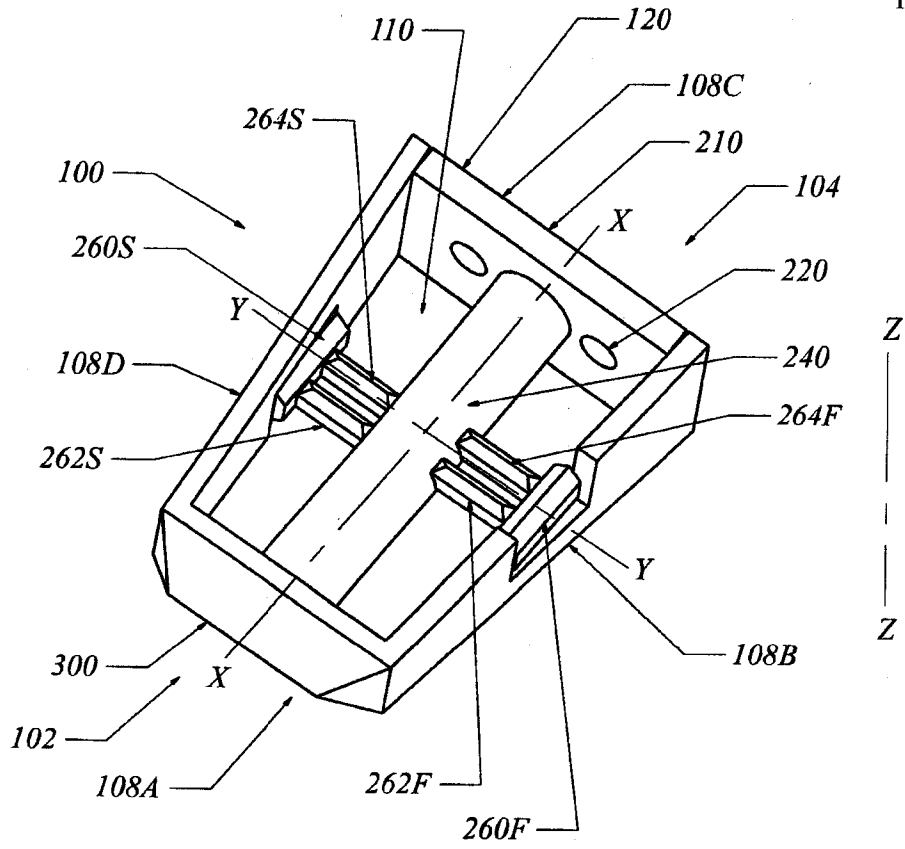

Fig 1

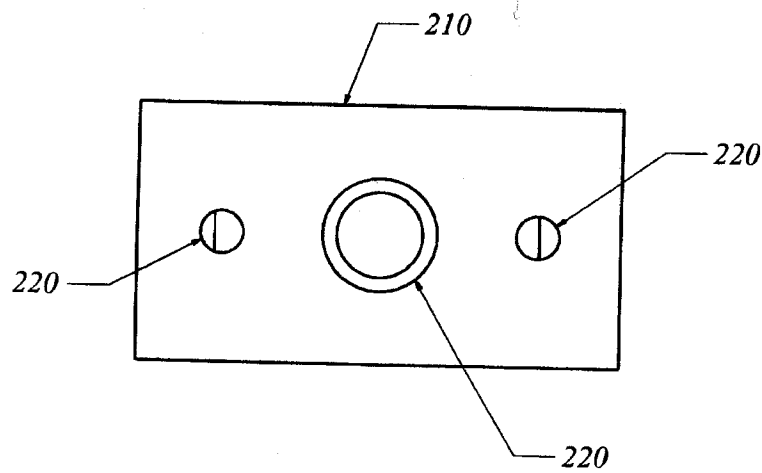

Fig 2

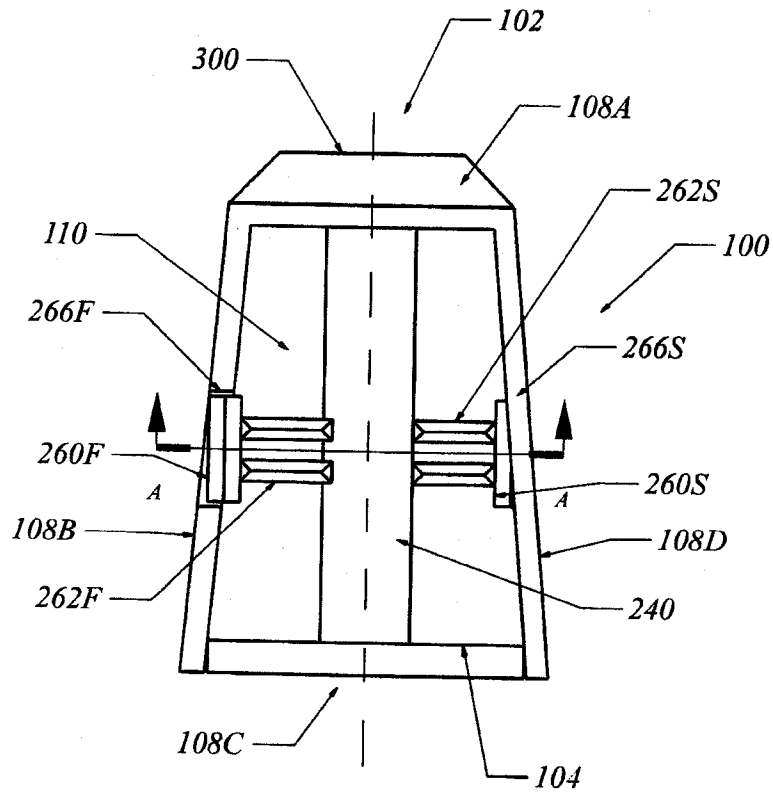

Fig 3

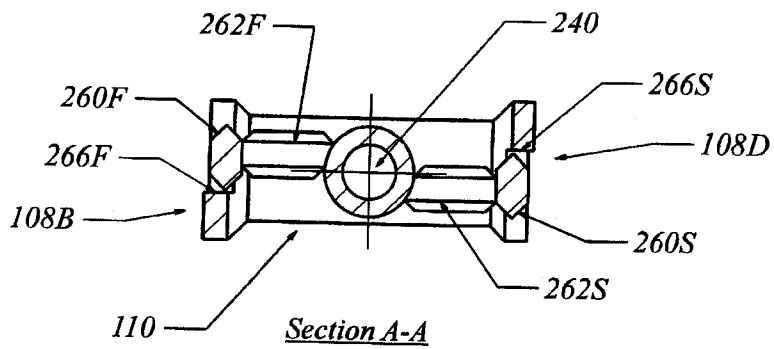

Fig 4

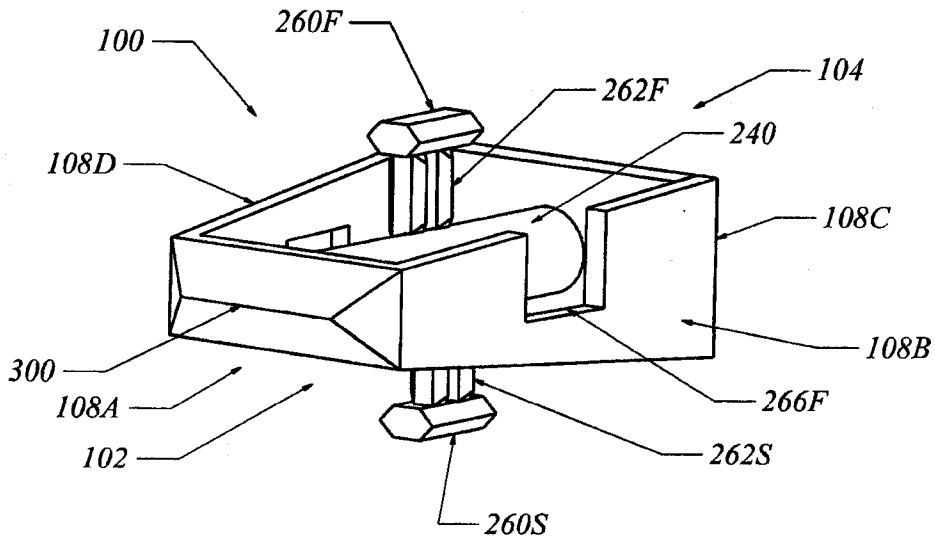

Fig 5

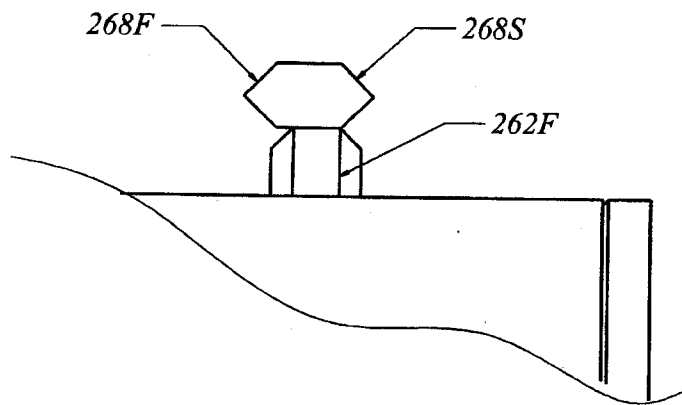

Fig 6

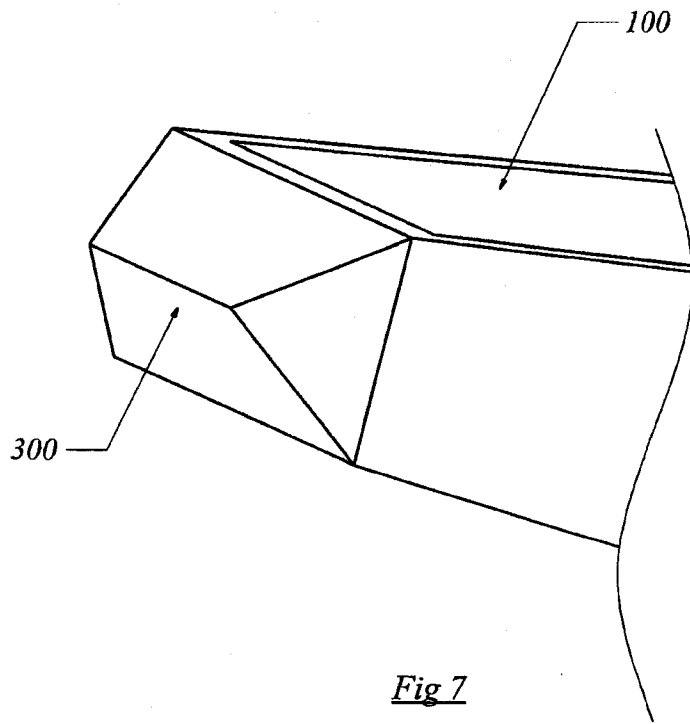

Fig 7

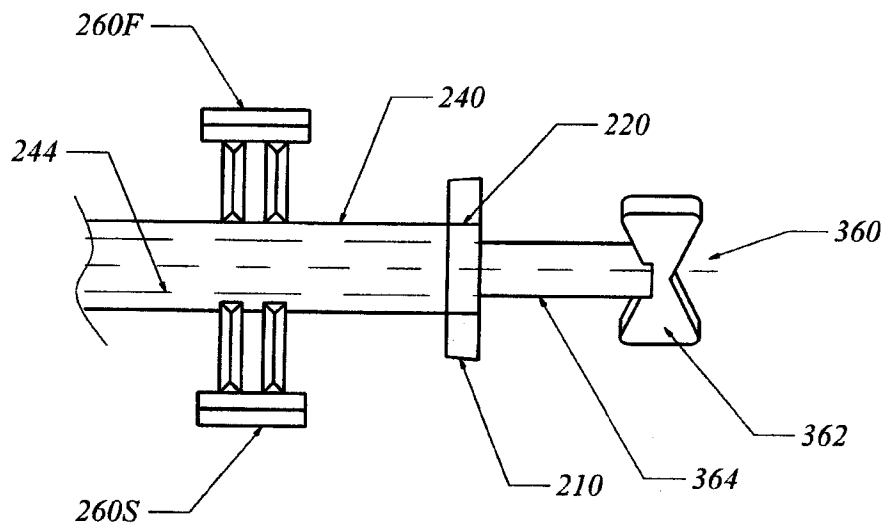

Fig 8

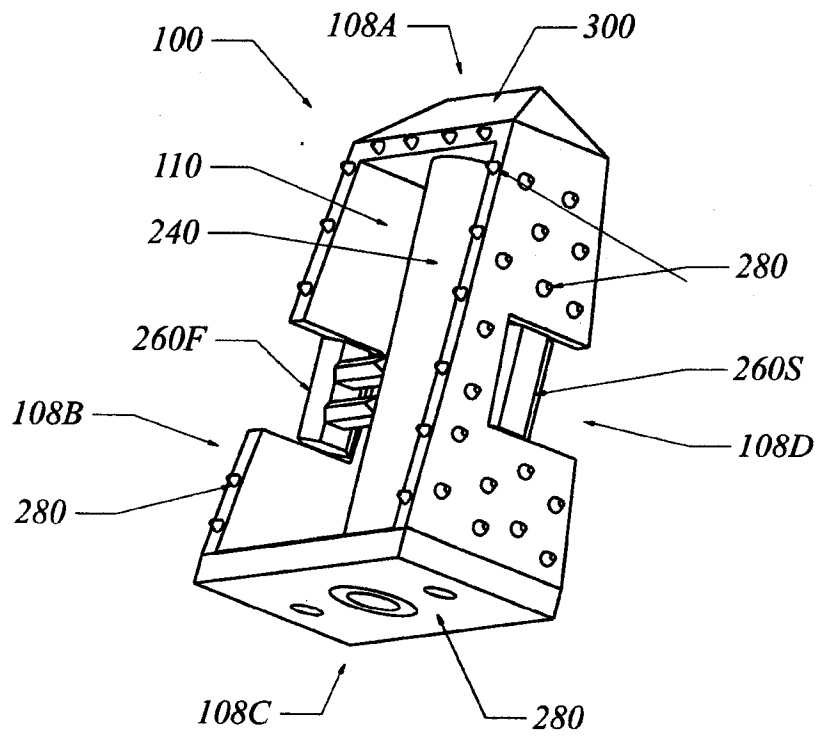

Fig 9

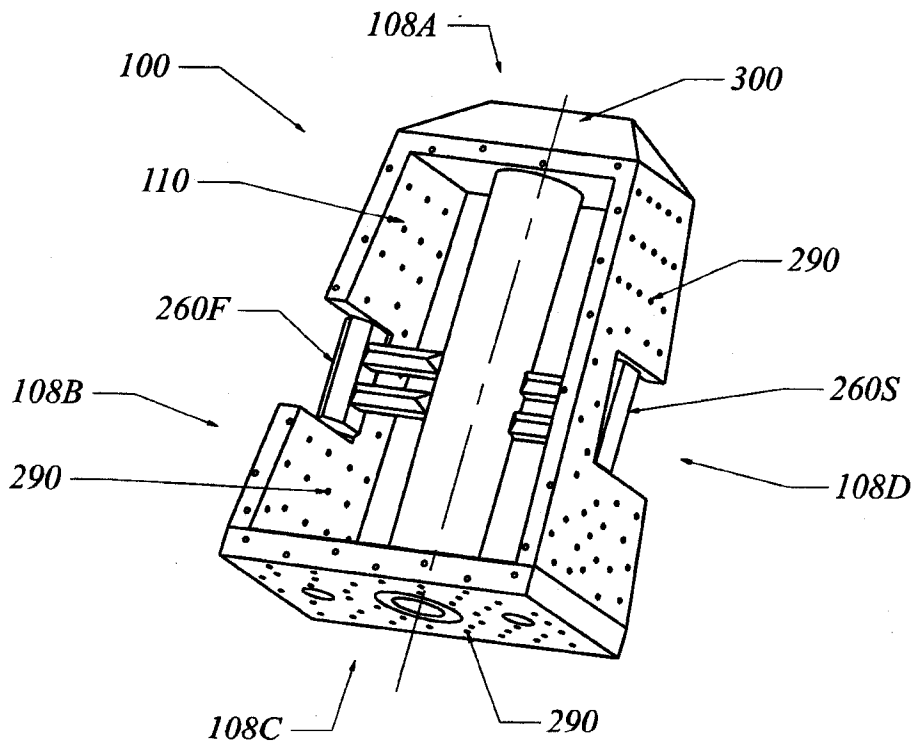

Fig 10

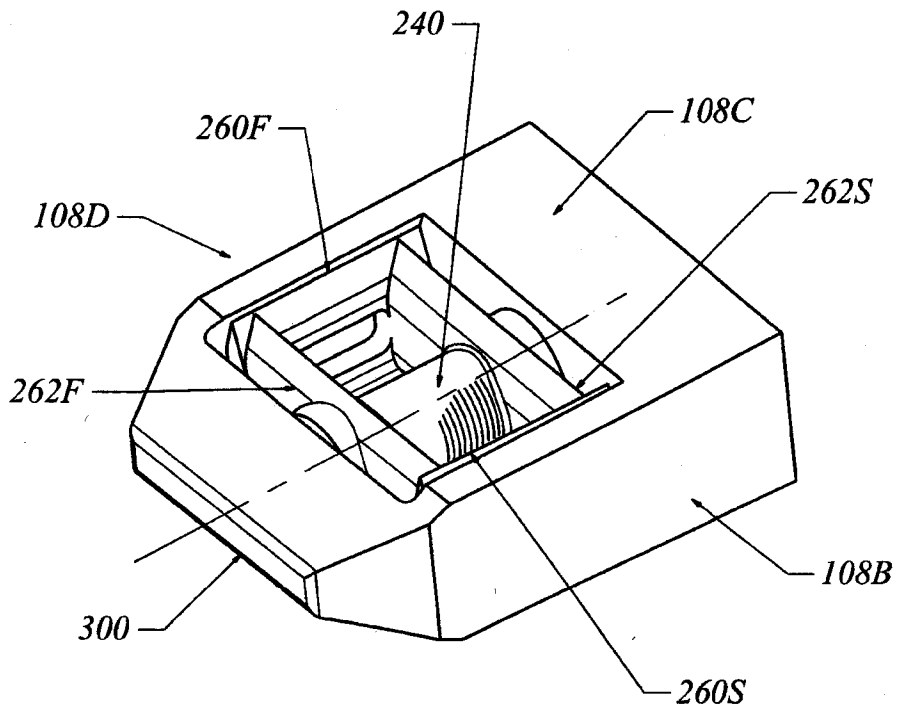

Fig 11

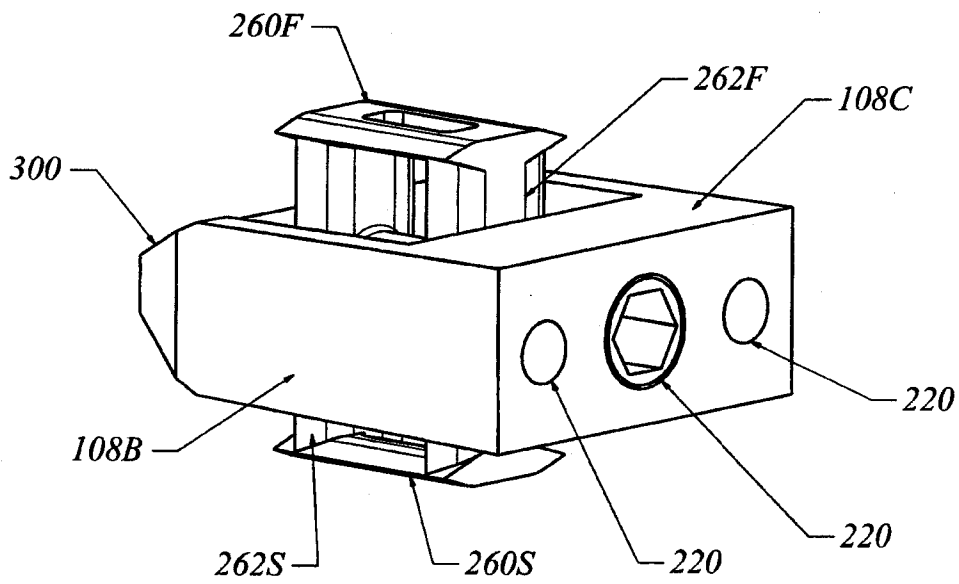

Fig 12

INTERNATIONAL SEARCH REPORT

International application No.

PCT/US2018/025785

A. CLASSIFICATION OF SUBJECT MATTER

IPC(8) - A61F 2/00; A61F 2/02; A61F 2/30; A61F 2/44 (2018.01)

CPC - A61F 2/447; A61F 2002/30261; A61F 2002/30271; A61F 2/4455 (2018.05)

According to International Patent Classification (IPC) or to both national classification and IPC

B. FIELDS SEARCHED

Minimum documentation searched (classification system followed by classification symbols)

See Search History document

Documentation searched other than minimum documentation to the extent that such documents are included in the fields searched

USPC - 606/60; 606/246; 623/17.11; 623/17.16 (keyword delimited)

Electronic data base consulted during the international search (name of data base and, where practicable, search terms used)

See Search History document

C. DOCUMENTS CONSIDERED TO BE RELEVANT

Category*	Citation of document, with indication, where appropriate, of the relevant passages	Relevant to claim No.
Y	US 2014/0094918 A1 (VISHNUBHOLTA et al) 03 April 2014 (03.04.2014) entire document	1-20
Y	US 2014/0114421 A1 (TITAN SPINE, LLC) 24 April 2014 (24.04.2014) entire document	1-20
Y	US 2015/0265416 A1 (INTERNATIONAL SPINAL INNOVATIONS LLC) 24 September 2015 (24.09.2015) entire document	2-5, 7-12
Y	US 2003/0187436 A1 (BOLGER et al) 02 October 2003 (02.10.2003) entire document	4, 5, 11, 12, 20
Y	US 2007/0118220 A1 (LIU et al) 24 May 2007 (24.05.2007) entire document	14-20

 Further documents are listed in the continuation of Box C. See patent family annex.

* Special categories of cited documents:

"A" document defining the general state of the art which is not considered to be of particular relevance

"E" earlier application or patent but published on or after the international filing date

"L" document which may throw doubts on priority claim(s) or which is cited to establish the publication date of another citation or other special reason (as specified)

"O" document referring to an oral disclosure, use, exhibition or other means

"P" document published prior to the international filing date but later than the priority date claimed

"T" later document published after the international filing date or priority date and not in conflict with the application but cited to understand the principle or theory underlying the invention

"X" document of particular relevance; the claimed invention cannot be considered novel or cannot be considered to involve an inventive step when the document is taken alone

"Y" document of particular relevance; the claimed invention cannot be considered to involve an inventive step when the document is combined with one or more other such documents, such combination being obvious to a person skilled in the art

"&" document member of the same patent family

Date of the actual completion of the international search

21 May 2018

Date of mailing of the international search report

11 JUN 2018

Name and mailing address of the ISA/US

Mail Stop PCT, Attn: ISA/US, Commissioner for Patents
P.O. Box 1450, Alexandria, VA 22313-1450

Facsimile No. 571-273-8300

Authorized officer

Blaine R. Copenheaver

PCT Helpdesk: 571-272-4300
PCT OSP: 571-272-7774