

(19)



Europäisches Patentamt
European Patent Office
Office européen des brevets



(11)

EP 1 114 778 A1

(12)

EUROPEAN PATENT APPLICATION

(43) Date of publication:

11.07.2001 Bulletin 2001/28

(51) Int Cl.7: B65D 1/32, B65D 47/06

(21) Application number: 00200007.3

(22) Date of filing: 04.01.2000

(84) Designated Contracting States:

DE

Designated Extension States:

AL LT LV MK RO SI

(72) Inventor: Jordan, Steven Paul

Prestwood, Great Missenden, Bucks (GB)

(74) Representative: Ottevangers, Sietse Ulbe et al

Vereenigde,

Postbus 87930

2508 DH Den Haag (NL)

(71) Applicant: Sara Lee/DE N.V.

3532 AA Utrecht (NL)

(54) Liquid container

(57) A liquid container is provided with a flexible holder (1) with a discharge opening (12), and a closing device (3). From the flexible holder (1), when being deformed, liquid in the container can be taken out. The container is closed by a siphon trap (7). The width of the

opening in the siphon trap (7) is such that, when the container is held with the discharge opening directed downwards and depending on the viscosity of the liquid in the container, only by deformation of the flexible holder (1) liquid is dispensed out of the container.

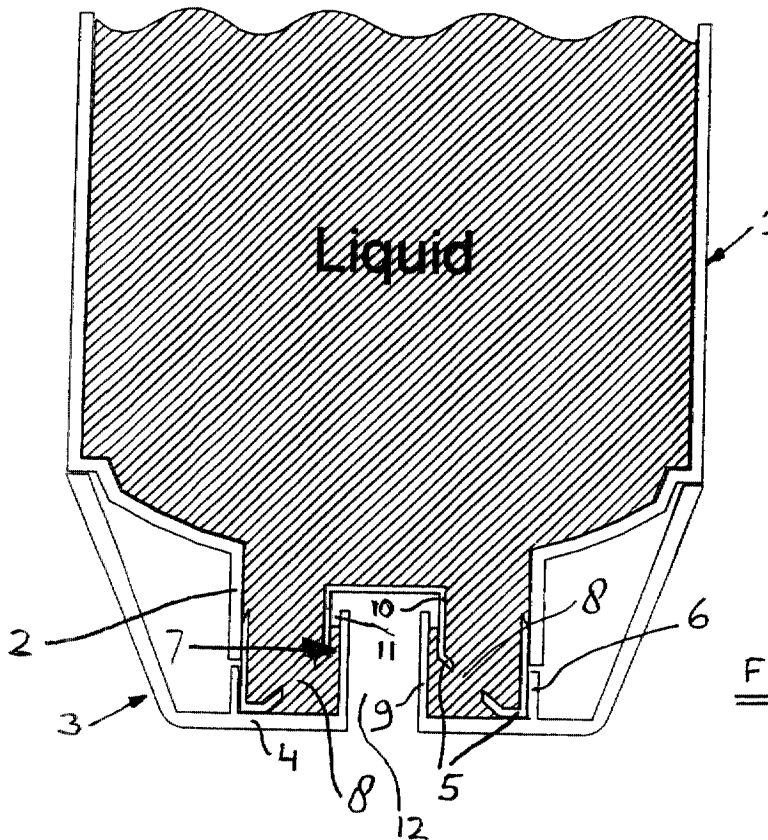

FIG. 1

EP 1 114 778 A1

Description

[0001] The present invention relates to a liquid container with a flexible holder, provided with a discharge opening, and a closing device, from which flexible holder, when being deformed, liquid in the container can be taken out.

[0002] Such a liquid container is known and is used to take a viscous liquid out of the container by squeezing and subsequently deforming the flexible holder, while holding the liquid container with the discharge opening directed downwardly. The known liquid containers are provided with a closing device by means of which the discharge opening is closed when the liquid container is not in use, which discharge opening is released by removing the closing device. The disadvantage of the known liquid containers is that when squeezing the flexible holder is stopped, while the liquid container is still in a position with the discharge opening directed downwardly, liquid will drip for a short time. To avoid such a dripping after having stopped squeezing the flexible holder, the liquid container must immediately be brought into a position with the discharge opening directed upwardly. This, however, slows down a repeated taking out of liquid.

[0003] The purpose of the invention is to obviate the above disadvantages and to provide for a liquid container with a simple, cheap and reliable construction.

[0004] According to the invention the liquid container as described in the opening paragraph is characterized in that the container is closed by a siphon trap.

[0005] By this measure the liquid container can be put on a carrier plane with the discharge opening directed downwardly, so that when the liquid container is seized and the holder is squeezed, the liquid flows out of the liquid container. After that squeezing of the holder is stopped, the liquid container can be put on a plane again with the discharge opening directed downwardly. By the siphon trap no further liquid will flow out of the container.

[0006] In a specific embodiment the closing device comprises a cap, and the siphon trap is formed by the cap and an inner necklike part, connected with the container. Particularly the inner necklike part fits in a neck part of the container and is provided with one or more openings. Further, the cap can be provided with a neck part which fits around said inner necklike part. Of course other connections between the inner necklike part and the neck part of the container and between the inner necklike part and the neck part of the cap are possible, e.g. by a screwed pipe connection.

[0007] In order to preserve the liquid in the container for a longer time, it is favourable when a cover is provided to close the discharge opening.

[0008] The width of the opening in the siphon trap may be such that, when the liquid container is held with the discharge opening directed downwardly and taking into account the viscosity of the liquid in the container, only by deformation of the flexible holder liquid is dispensed

out of the container.

[0009] An embodiment of the liquid container according to the invention will be further explained in the following description with reference to the accompanying drawings, in which:

Fig. 1 shows part of a liquid container according to the invention in a rest position and ready for use; and

Fig. 2 shows said part of the liquid container while the flexible holder is squeezed.

[0010] In figs. 1 and 2 a liquid container comprises a flexible holder 1 with a neck part 2, a closing device 3 with a cap 4 and an inner necklike part 5. The holder can be formed by a collapsible tube, a bottle of synthetic material or suchlike units. The cap is provided with a neck part 6. The liquid container is closed by a siphon trap 7 formed by the cap 4 and the inner necklike part 5. The inner neck part 5 fits in the neck part 2 of the flexible holder 1, while the neck part 6 of the cap 4 fits around the inner necklike part 5. The inner necklike part 5 is fixed in the neck part 2 of the flexible holder 1 and provided with one or more openings 8. The cap 4 is fixed around the inner necklike part 5. The cap 4 has an inner bushlike element 9, which, when the cap 4 is fixed around the inner necklike part 5, extends partly in a bushlike part 10 of the inner necklike part 5. As already mentioned the siphon trap 7 is formed by the cap 4 and the inner necklike part 5. More particularly, the siphon trap 7 is formed by the bushlike elements 9 and 10. Between both bushlike elements 9 and 10 an opening 11 is provided, the width of which is depending on e.g. the viscosity of the liquid in the container. When the liquid container is not in use, the discharge opening 12 of the container can be closed by a cover, not shown in the figures.

[0011] When the flexible holder 1 is in a rest position (fig. 1) the liquid will enter the siphon trap 7 at a level below the top of the bushlike element 9. When the holder is squeezed (fig. 2), the liquid in the flexible holder 1 is forced downwards and the liquid level in the siphon trap 7 rises above the upper edge of the bushlike element 9 and dispenses as shown in fig. 2.

[0012] It will be clear that the invention is not restricted to the embodiment described above and illustrated in the figures. It will be clear to the skilled man that, within the scope of the invention as defined by the appended claims, many alternatives are possible.

Claims

1. Liquid container with a flexible holder (1), provided with a discharge opening (12), and a closing device (3), from which flexible holder (1), when being deformed, liquid in the container can be taken out, characterized in that the container is closed by a

siphon trap (7).

2. Liquid container according to claim 1, characterized in that the closing device (3) comprises a cap (4), and the siphon trap (7) is formed by the cap (4) and an inner necklike part (5), connected with the container. 5
3. Liquid container according to claim 2, characterized in that the inner necklike part (5) fits in a neck part (2) of the container and is provided with one of more openings (8). 10
4. Liquid container according to claim 2 or 3, characterized in that the cap (4) is provided with a neck part (6) which fits around said inner necklike part (5). 15
5. Liquid container according to any one of the preceding claims, characterized in that a cover is provided to close the discharge opening (12). 20
6. Liquid container according to any one of the preceding claims, characterized in that the width of the opening (11) in the siphon trap (7) is such that, when the liquid container is hold with the discharge opening (12) directed downwardly and taking into account the viscosity of the liquid in the container, only by deformation of the flexible holder (1) liquid is dispensed out of the container. 25
30

35

40

45

50

55

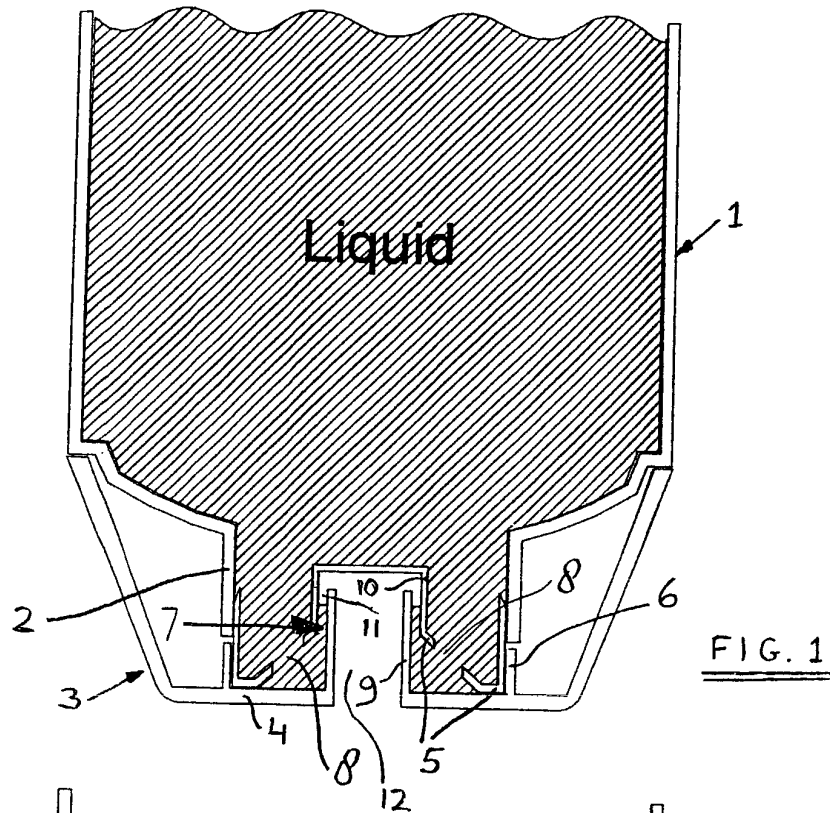

FIG. 1

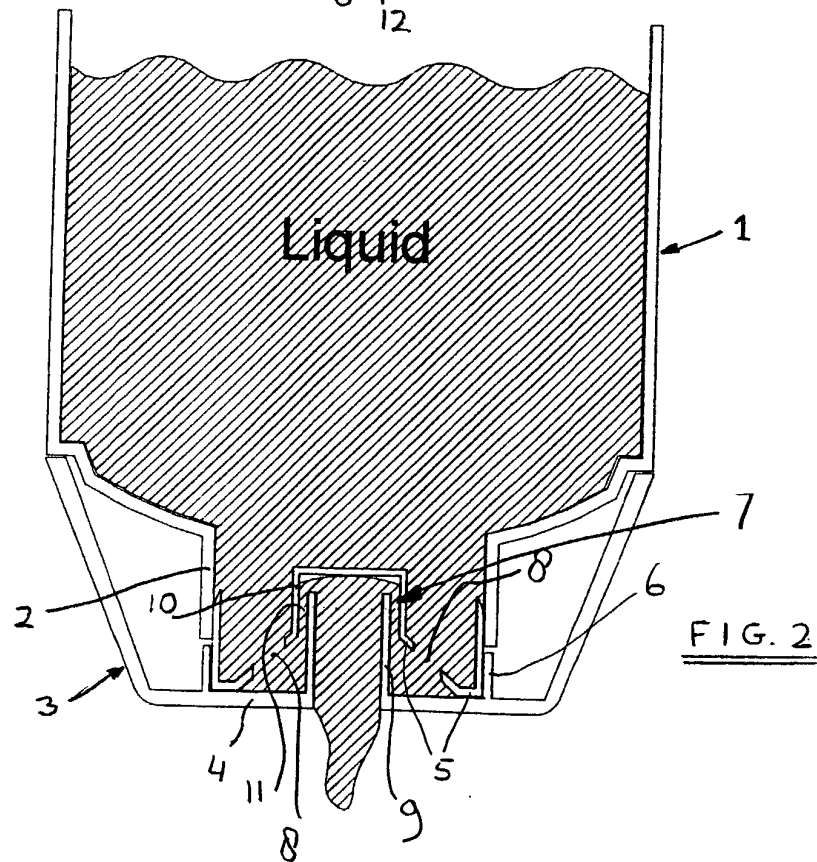

FIG. 2



European Patent Office

EUROPEAN SEARCH REPORT

Application Number
EP 00 20 0007

DOCUMENTS CONSIDERED TO BE RELEVANT			
Category	Citation of document with indication, where appropriate, of relevant passages	Relevant to claim	CLASSIFICATION OF THE APPLICATION (Int.Cl.7)
X	US 4 324 349 A (KAUFMAN JOHN G) 13 April 1982 (1982-04-13) * column 4, line 37 - column 5, line 11; figure 2 * ---	1,2,4-6	B65D1/32 B65D47/06
X	US 5 904 272 A (KAUFMAN JOHN G ET AL) 18 May 1999 (1999-05-18) * column 4, line 12 - line 28; claim 1; figure 5 * ---	1-4,6	
X	US 3 157 319 A (SCHWIENBACHER) 17 November 1964 (1964-11-17) * column 1, line 45 - column 2, line 22; figures * -----	1,6	
			TECHNICAL FIELDS SEARCHED (Int.Cl.7)
			G01F B65D
The present search report has been drawn up for all claims			
Place of search THE HAGUE		Date of completion of the search 26 May 2000	Examiner Bridault, A
CATEGORY OF CITED DOCUMENTS X : particularly relevant if taken alone Y : particularly relevant if combined with another document of the same category A : technological background O : non-written disclosure P : intermediate document		T : theory or principle underlying the invention E : earlier patent document, but published on, or after the filing date D : document cited in the application L : document cited for other reasons ----- & : member of the same patent family, corresponding document	

EPO FORM 1503 03/82 (P04C01)

ANNEX TO THE EUROPEAN SEARCH REPORT
ON EUROPEAN PATENT APPLICATION NO.

EP 00 20 0007

This annex lists the patent family members relating to the patent documents cited in the above-mentioned European search report. The members are as contained in the European Patent Office EDP file on
The European Patent Office is in no way liable for these particulars which are merely given for the purpose of information.

26-05-2000

Patent document cited in search report	Publication date	Patent family member(s)	Publication date
US 4324349 A	13-04-1982	AT 19036 T	15-04-1986
		AU 542812 B	14-03-1985
		AU 6775981 A	07-08-1981
		BR 8105997 A	24-11-1981
		DE 3174288 D	15-05-1986
		EP 0043846 A	20-01-1982
		JP 57500183 T	04-02-1982
		WO 8101993 A	23-07-1981
US 5904272 A	18-05-1999	AU 1017499 A	31-05-1999
		WO 9923925 A	20-05-1999
US 3157319 A	17-11-1964	CH 398312 A	
		DE 1176015 B	
		GB 1021262 A	

EPO FORM P0459

For more details about this annex : see Official Journal of the European Patent Office, No. 12/82