

J. T. STONEY.
MOLDING MACHINE.
APPLICATION FILED SEPT. 23, 1910.

1,004,708.

Patented Oct. 3, 1911.

4 SHEETS-SHEET 1.

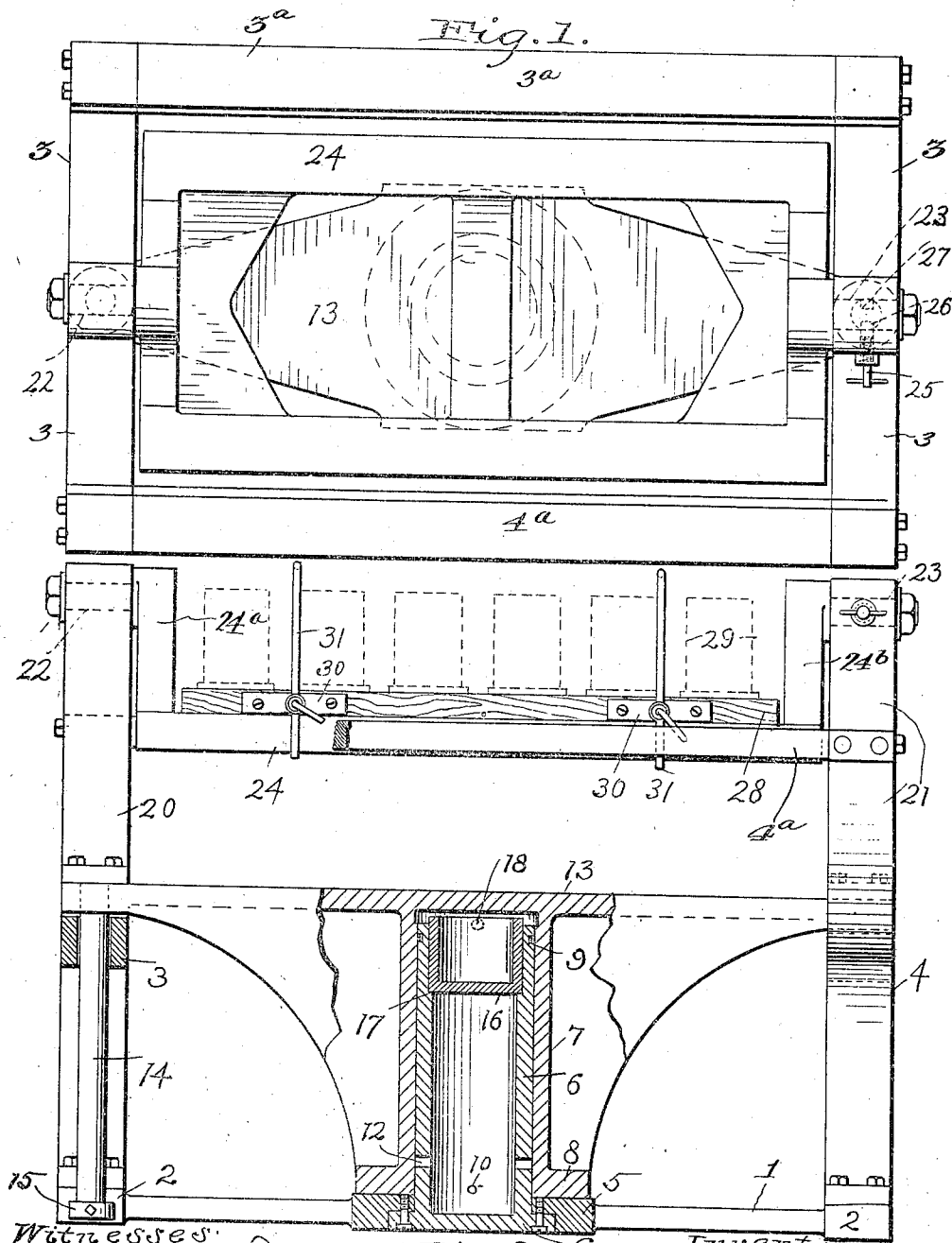

Witnesses:
E. B. Gilchrist
H. B. Sullivan

Fig. 2

Inventor:
John T. Stoney
by Thurston & Kwis
Attys

J. T. STONEY.
MOLDING MACHINE.
APPLICATION FILED SEPT. 23, 1910.

1,004,708.

Patented Oct. 3, 1911.

4 SHEETS—SHEET 2.

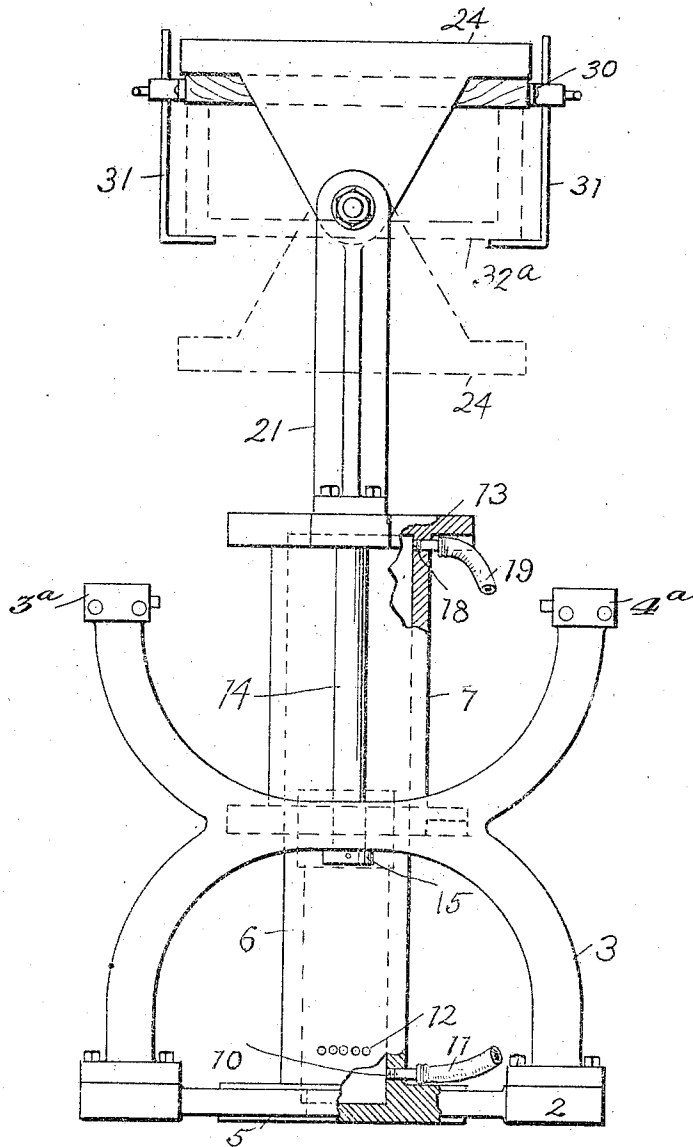

Fig. 3.

Witnesses,
E. B. Gilchrist,

H. R. Sullivan.

Inventor,
John T. Stoney
by Thurston & Spria
attys

J. T. STONEY.
MOLDING MACHINE.
APPLICATION FILED SEPT. 23, 1910.

1,004,708.

Patented Oct. 3, 1911.

4 SHEETS—SHEET 3.

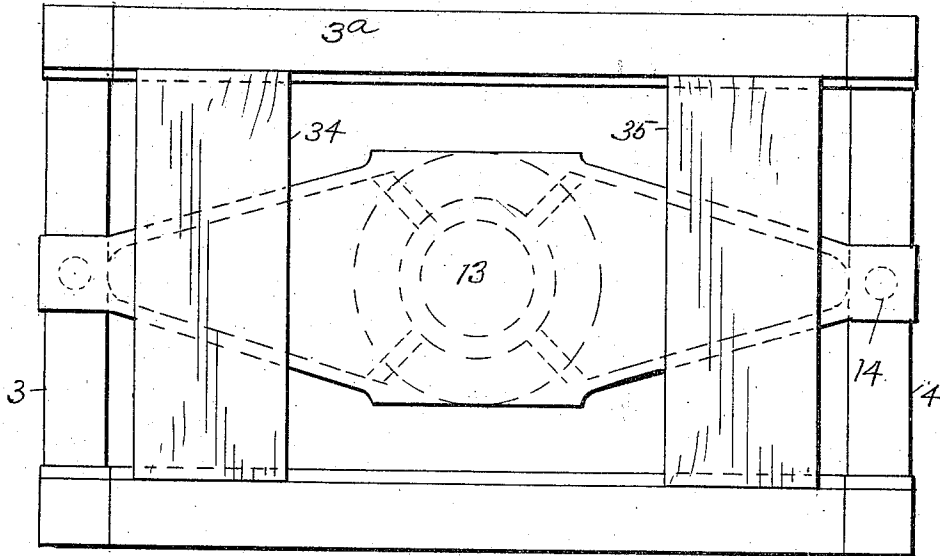

Fig. 4. 4a

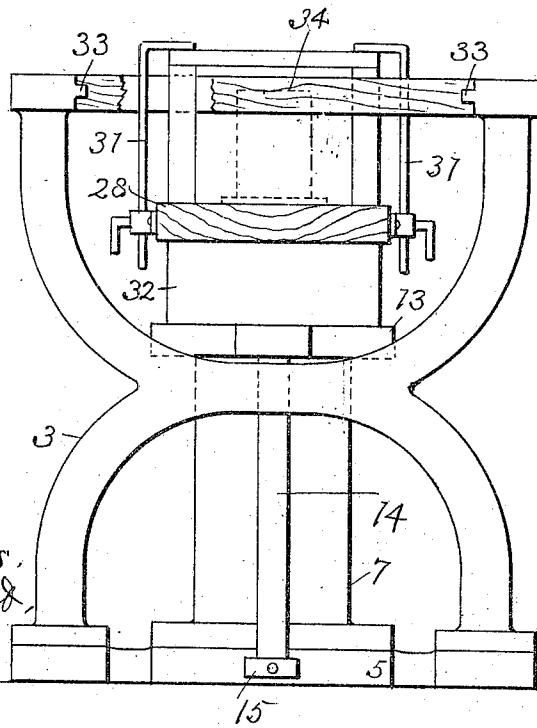

Fig. 5.

Witnesses,
E. B. Gilchrist,
H. P. Sullivan

Inventor,
John T. Stoney
by Thurston & Sons
attys.

J. T. STONEY.
MOLDING MACHINE.
APPLICATION FILED SEPT. 23, 1910.

1,004,708.

Patented Oct. 3, 1911

4 SHEETS—SHEET 4.

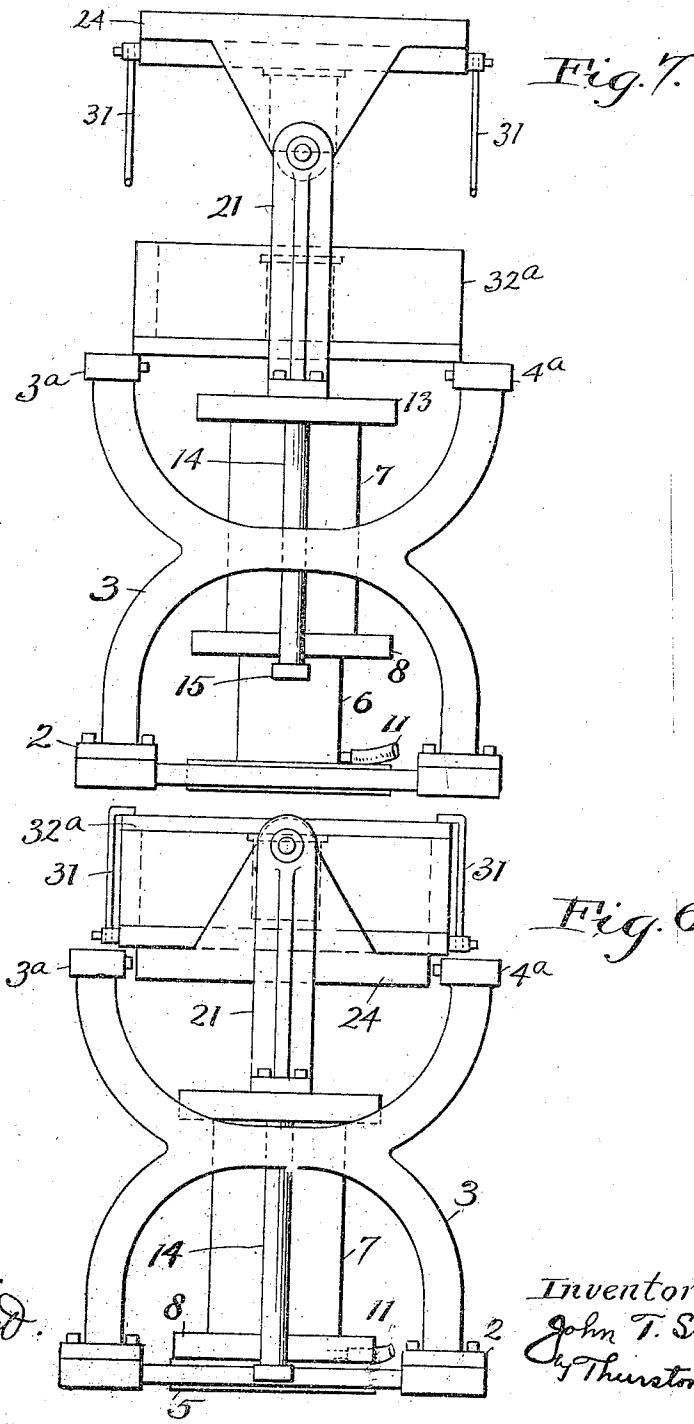

Witnesses:
E. B. Gilchrad.
H. R. Sullivan.

Inventor
John T. Stoney
By Thurston & Davis
Attys.

UNITED STATES PATENT OFFICE.

JOHN T. STONEY, OF CLEVELAND, OHIO.

MOLDING-MACHINE.

1,004,708.

Specification of Letters Patent.

Patented Oct. 3, 1911.

Application filed September 23, 1910. Serial No. 533,415.

To all whom it may concern:

Be it known that I, JOHN T. STONEY, a citizen of the United States, residing at Cleveland, in the county of Cuyahoga and State of Ohio, have invented a certain new and useful Improvement in Molding-Machines, of which the following is a full, clear, and exact description.

My invention relates to a molding machine and more particularly to the class of such machines wherein fluid pressure is employed as a force to vibrate the mold and accomplish the raising and lowering of the mold.

It provides a construction wherein the mold may be easily rolled over and a pattern withdrawn either with or without the use of a stripping plate.

Further the invention provides a simple construction for vibrating and raising and lowering the mold.

Generally speaking, the invention comprises the elements and combinations thereof set forth in the claims.

Reference should be had to the accompanying drawings forming a part of this application in which—

Figure 1 is a top plan view of the molding machine; Fig. 2 is a side elevation with certain parts in section; Fig. 3 is an end elevation; Fig. 4 is a top plan view of the machine with the top portion removed; Fig. 5 is an end elevation of the showing in Fig. 4; Fig. 6 is a side elevation of the machine in position to jar the mold; and Fig. 7 is a side elevation of the machine in position just after the patterns have been drawn.

The base 1 is provided with end pieces 2 which support upright side pieces 3 and 4. These side pieces assume the general shape shown in Fig. 3, although other shapes may be employed with equal facility. Upon the base 1 an anvil 5 is supported which is for the purpose of receiving the impact when the platform carrying the mold is allowed to drop. This anvil may be formed integral with the base, as shown, or if desired, may be separately constructed and attached thereto. The anvil 5 is provided with a central opening through which extends a fluid pressure cylinder 6, and this cylinder is secured to the anvil 5 in any desired manner; one form being shown in Fig. 2. A sliding member 7 surrounds the cylinder and is provided with the flange 8 at the lower end

thereof, which normally rests upon the anvil 5. It will be understood that the cylinder 6 and the sliding member 7 are fitted to each other so as to permit an easy slide between the members and yet not allow any loose play.

The cylinder 6 is provided with a packing ring 9 near the upper end thereof, which is for the purpose of preventing the escape of air through such space as may exist between the cylinder and the sliding member. Near the lower end of this cylinder a port 10 is provided which is connected with a suitable source of fluid under pressure by means of a flexible tube, such as indicated at 11. The valves for controlling the admission of fluid to the cylinder form no part of this invention, and as forms of valves suitable for this purpose are common, further description is not believed to be necessary. The cylinder 6 is also provided with exhaust ports 12 which are situated at a short distance above the lower end of the cylinder, and these ports are normally kept closed by the sliding member 7. When, however, the sliding member 7 is raised due to the admission of a fluid within the cylinder, to such a point so as to uncover the ports 12, then the fluid within the cylinder will be permitted to pass out of the ports 12 which will in turn destroy the pressure which has heretofore held the sliding member in elevated position, and the sliding member will thereby be permitted to drop of its own gravity and impact against the anvil 5. As soon as the sliding member has reached its lowest position, the fluid which is still being admitted through the port 10 will again create a pressure to raise the sliding member 7, and again the fluid will be permitted to exhaust through the ports 12. The admission port 10 and the outlet ports 12 are so arranged that this up and down movement of the sliding member 7 takes place with great rapidity and amounts to a vibration.

At its upper end, the member 7 supports a platform 13 which is connected with or integral with the sliding member 7. This platform extends to the side pieces 3 and 4. To the ends of the platform 13, rods are fixed, one of which is shown at 14, and depends through the end member 3. This rod at its lower end is provided with an adjustable collar 15 for a purpose to be later described.

In the upper end of the cylinder 6 is a cup shaped piston 16 which is of slightly larger external diameter than the internal diameter of the cylinder, the cylinder 6 being sufficiently enlarged at that portion where the member 16 is placed, to provide an opening to accommodate the piston with a close but working fit. The piston rests upon shoulders 17 which are formed in the interior surface of the cylinder. When the fluid is admitted to the port 10 and creates a pressure within the interior of the cylinder, the piston 16 is raised and contacts with the platform 13, which, as before described, is either integral or attached to the sliding member 7, and thereby the platform is raised.

For the purpose of raising the platform and holding the same without vibratory movement, a port 18 is provided in the sliding member 7, and this port is connected with a suitable source of fluid under pressure, as by means of a flexible tube 19 indicated in Fig. 3. If, therefore, a fluid be admitted through the port 18, it will exert a pressure within the cup shaped piston 16, and inasmuch as this piston cannot descend because of the shoulder 17, the pressure thus exerted will cause the platform 13 to rise, and this movement will continue until such time as the stop 15 abuts against that portion of the side member 3 through which it extends. As before stated, this member 15 is adjustable so that the extent of movement of the platform 13 may be regulated. The fluid control for this portion of the machine will be arranged with a valve which when turned in certain directions will permit the air to exhaust from this portion of the machine through the same tube 19.

At the end portions of the platform 13 are uprights 20 and 21, the same being secured to the platform in any suitable manner. At their upper ends, these uprights are formed with journals which accommodate stub shafts 22 and 23, each of which shafts is provided with an arm 24^a and 24^b that supports a platform 24. Through the upright 21 there extends a pin 25, which coöperates with a depression 26 formed in the stub shaft 23 to hold the platform 24 from swinging. This shaft 26 is likewise provided with a depression 27 arranged upon the shaft directly opposite the depression 26 and is for the purpose of holding the platform from movement, when the same is swung to its upper position, as indicated in Fig. 3. A plate 28 which carries the patterns 29 is supported upon the platform 24 in any desired manner and this plate is provided with plates 30, to which are removably secured clamping members 31, as indicated in Figs. 2 and 3. The flask

is placed upon the plate 28 and the clamping members are arranged to hold the flask upon the plate, as indicated in Fig. 3.

When the flask is first placed upon the plate 28, the machine and its parts occupy the position substantially as shown in Fig. 2. The sand is then placed within the flask and the fluid is admitted through the port 10, and exhausted through the ports 12, in a manner as heretofore explained, which vibration causes the sand to pack around the patterns and the mold is thus formed. When the mold is completely formed, a board is placed over the top of the mold, as indicated at 32^a, in Fig. 3, and is held in place by the clamps. The mold is then raised and the pin 25 is withdrawn; the platform 24 is rolled over and the pin 25 allowed to seat itself in the opening 27 in the shaft 26, whereby the mold will be held in its inverted position, as shown in Fig. 3. The mold is next lowered until the flask rests upon the sides 3^a and 4^a. The clamps 31 may then be released and the air admitted through the pipe 19 to the upper side of the piston 16, whereupon the platform 24 and the patterns will be raised away from the mold. The mold may then be withdrawn; the platform 24 returned to its original position, and the operation again repeated.

For certain operations, it may be desirable to dispense with the turning over mechanism, and when such is the case, the uprights 20 and 21 are removed, together with all the mechanism which they carry. The patterns 29 and the plate 28 to which they are secured are then mounted upon the platform 13 but are usually shimmed up from this platform by means of a block, such as shown at 32, for the purpose of providing clearance, as will be hereinafter described. In such a construction, patterns, together with the plate 28 to which they are secured, form a part which is movable with the platform 13. The end pieces 3 and 4 are connected by side pieces 3^a and 4^a, which members upon their inner sides are formed with ribs 33. Sliding members 34 and 35 are provided in their ends with slots which are of proper size to coöperate with the flanges 33 and these members are adapted to slide so that they may be moved from the center to the ends of the machine. The flask will be secured upon the plate 28 in the same manner as heretofore indicated, and will be filled with sand and vibrated in the manner heretofore explained. After the mold is completed, the platform 13 will be raised by admitting air to the port 18 and then the members 34 and 35 will be slid inwardly from the ends until they underlie the edges of the flask, whereupon the clamps will be removed and the platform 13 returned to its original position. In this manner, the patterns will be removed from

the mold and thereafter the mold may itself be taken away.

If desired, a stripping plate may be used by placing the same beneath the flask before it is placed upon the plate 28.

Having thus described my invention, what I claim is:

1. In a molding machine, the combination with a mold supporting platform, of a fluid pressure cylinder, a sliding member cooperating with the cylinder and supporting the said platform, means for admitting a fluid to the cylinder, an exhaust port for the cylinder, said port being controlled by the sliding member to exhaust the cylinder when the sliding member has raised a certain amount, a sliding piston in the upper end of said cylinder, said piston being raised into contact with the sliding member when fluid is admitted to the cylinder.

2. In a molding machine, the combination with a mold supporting platform, of a fluid pressure cylinder, a sliding member cooperating with the cylinder and supporting said platform, means for admitting fluid to the cylinder, said port being controlled by the sliding member to exhaust the cylinder when the sliding member has been raised a certain amount, a sliding piston in said cylinder which is adapted to contact with the platform when fluid is admitted to the cylinder, means within the cylinder for limiting the downward movement of the piston, means for admitting air above the piston whereby the sliding member may be raised, and means for limiting the upward movement of the sliding member.

3. In a molding machine, the combination with a mold supporting platform, of a fluid pressure cylinder, a sliding member cooperating with the cylinder and supporting the said platform, means for admitting air to the cylinder to exhaust the air therefrom to impart a vibratory movement to the sliding member, a slidable piston mounted in the said cylinder, means for limiting the downward movement of said piston, means for admitting air above the piston whereby the platform will be raised, and adjustable means for limiting the upward movement of the sliding member.

4. In a molding machine, the combination with a mold supporting platform, of a fluid pressure cylinder, a sliding member cooperating with the cylinder and supporting the said platform, means for admitting a fluid to and exhausting the same from the cylinder to impart a vibratory motion to the

sliding member, a sliding cup shaped piston within the cylinder, means for limiting the movement of said piston in one direction, means for admitting air above the said piston to raise the sliding member, and means for limiting the movement of said sliding member.

5. In a molding machine the combination with a fluid pressure cylinder, of a sliding member associated with said cylinder, means for admitting a fluid to and discharging the same from the cylinder to impart a vibrating motion to the sliding member, means for admitting a fluid to a portion of said cylinder to raise the said sliding member, a swinging platform supported upon said sliding member, and means for holding said platform in adjusted position.

6. In a molding machine, the combination with a frame, of a cylinder supported by said frame, a sliding member cooperating with said cylinder, means for admitting a fluid to and discharging the same from the cylinder to vibrate the sliding member, other means for admitting air to a portion of the cylinder for raising the sliding member, and means for limiting the movement of the sliding member.

7. In a molding machine, the combination with a frame, of a fluid cylinder supported in said frame, a sliding member cooperating with the said cylinder, means for admitting a fluid to and from said cylinder to impart a vibratory movement thereto, other means for admitting fluid to another portion of the cylinder to raise the sliding member, and means slidably mounted upon the frame above the said cylinder and capable of movement toward and from the ends of the frame for the purpose specified.

8. In a molding machine, the combination with a frame, a fluid pressure cylinder carried by the frame, a sliding member cooperating with the cylinder, means for admitting and discharging air from said cylinder to impart a vibratory motion to the sliding member, and members slidably mounted upon the side pieces of the frame and adapted to move toward and from the ends of the frame, to support the mold when the pattern is withdrawn.

In testimony whereof, I hereunto affix my signature in the presence of two witnesses.

JOHN T. STONEY.

Witnesses:

H. R. SULLIVAN,
A. J. HUDSON.