

[54] **HOUSING FOR ROLLER BLINDS**

[72] Inventor: **Gunter Herms**, Kapellenstrasse 52, 52 Siegburg-Kaldauen, Germany

[22] Filed: **Jan. 6, 1970**

[21] Appl. No.: **887**

[30] **Foreign Application Priority Data**

Jan. 7, 1969 GermanyP 19 00 471.8
 Apr. 29, 1969 GermanyP 19 21 780.2

[52] U.S. Cl. **160/26**

[51] Int. Cl. **E06b 9/10**

[58] Field of Search 160/26, 180; 220/9 F, 29, 31, 220/80; 229/3.5 MF; 217/12, 57

[56] **References Cited**

UNITED STATES PATENTS

3,225,983 12/1965 Majka220/9 F X

3,064,874	11/1962	Kauffeld.....	229/3.5 MF
756,338	4/1904	Doten.....	217/12
3,024,939	3/1962	Kantor.....	220/80
1,748,406	2/1930	Blair.....	220/31 X
3,417,897	12/1968	Johnson.....	220/29 X
1,317,045	9/1919	Shawley.....	220/29 X
3,445,052	5/1969	Lewallen.....	220/9 F
3,372,832	3/1968	Yeater et al.	220/29
1,681,534	8/1928	Green.....	160/180 X

Primary Examiner—Peter M. Caun
 Attorney—Walter Becker

[57] **ABSTRACT**

A multi-sectional box for roller blinds and for sealing the masonry part receiving the roller blinds, in which portions of said box consist of foam material held together by a cover foil on the outside of said box while the sections of said box are held together by rail means.

7 Claims, 16 Drawing Figures

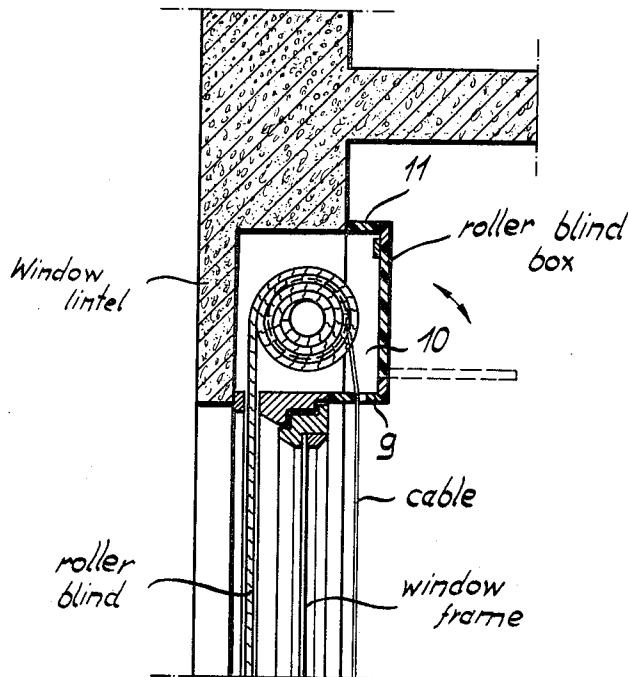

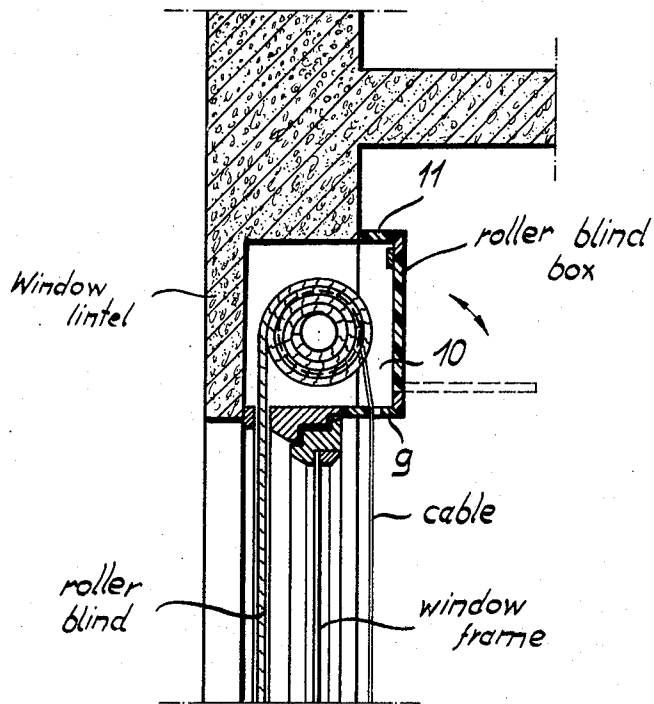

Fig. 1

INVENTOR
Günter Herms
By *Walter Buhner*

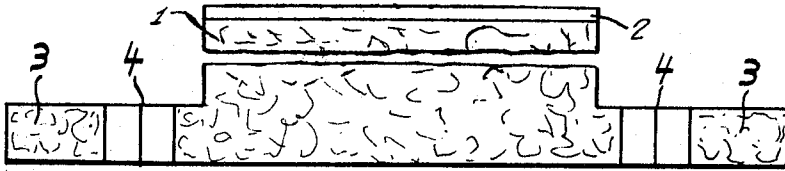

Fig. 1a

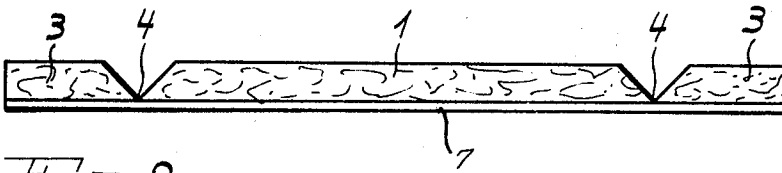

Fig. 2

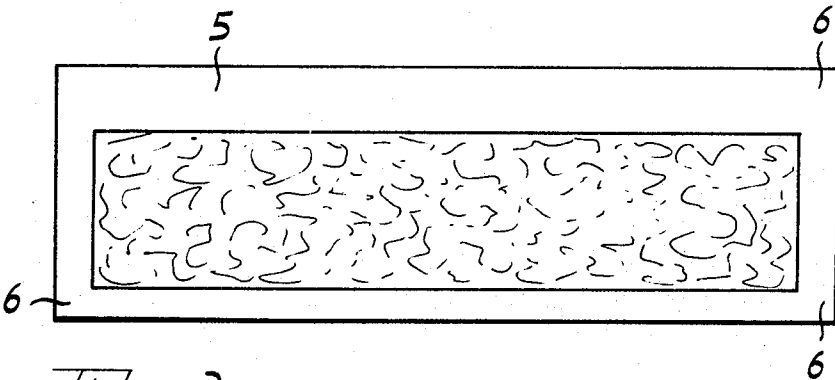

Fig. 3



Fig. 4

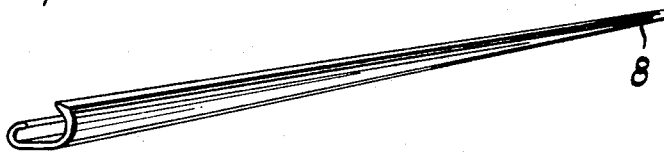

Fig. 5

INVENTOR

Gunter Herms

BY

Walter Busby

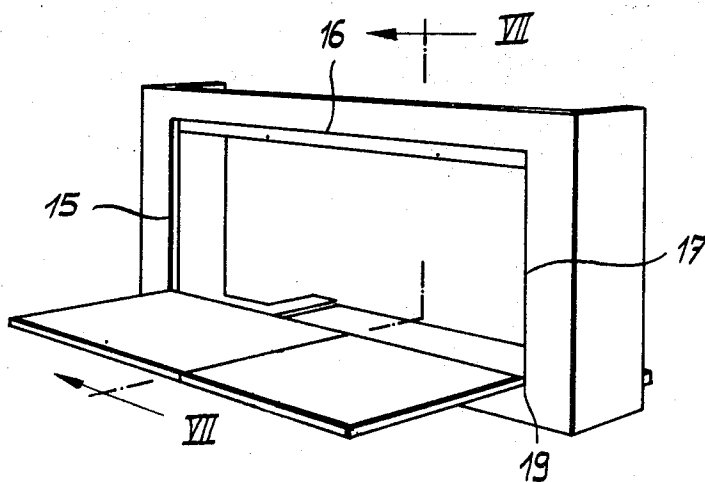

Fig. 6

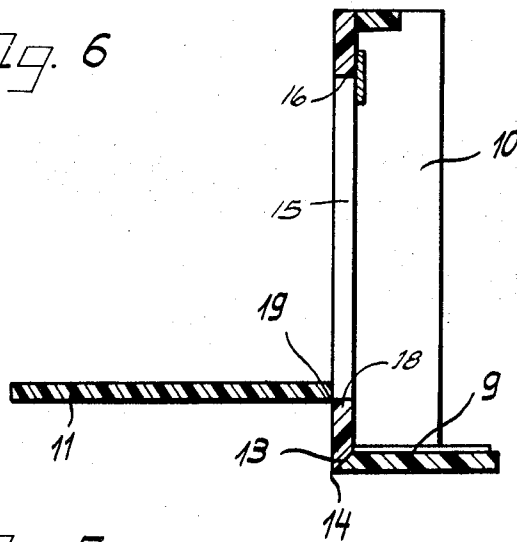

Fig. 7

INVENTOR
Günter Herms
By *Walter Doherty*

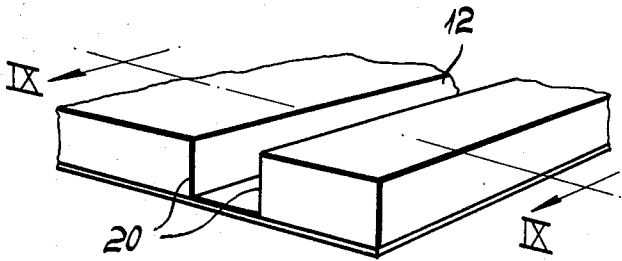

Fig. 8

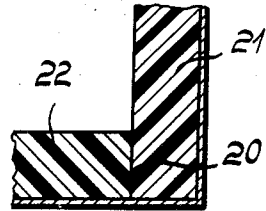

Fig. 9

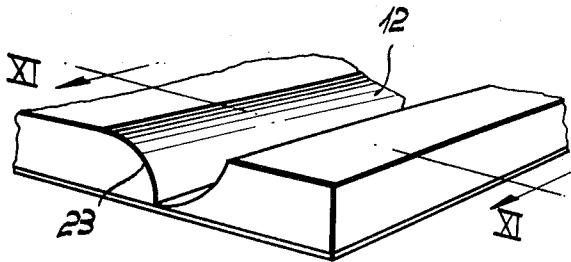

Fig. 10

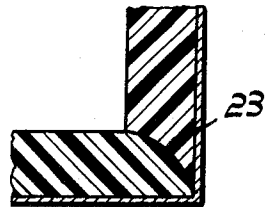

Fig. 11

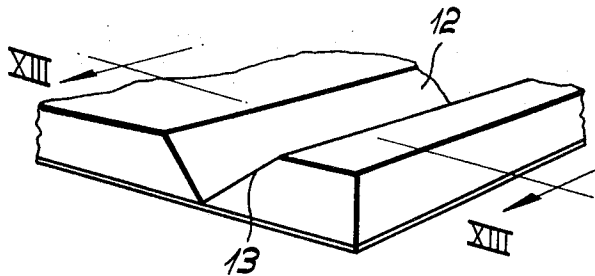

Fig. 12

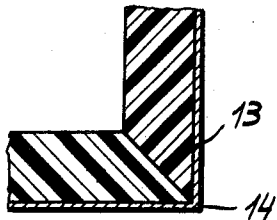

Fig. 13

INVENTOR

Günter Herms

By

Walter Duhay

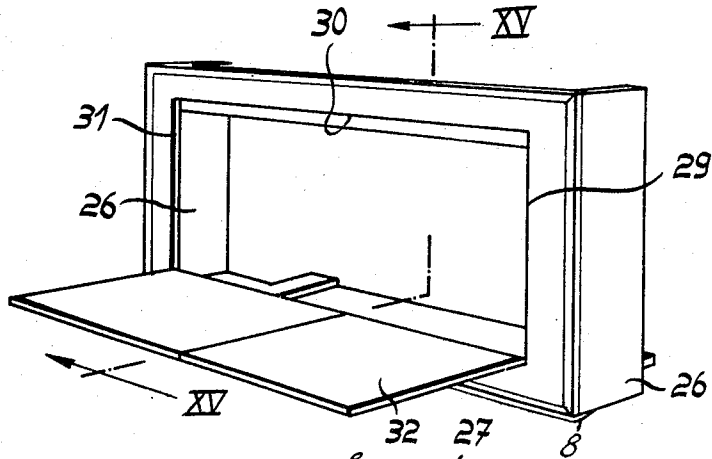

Fig. 14

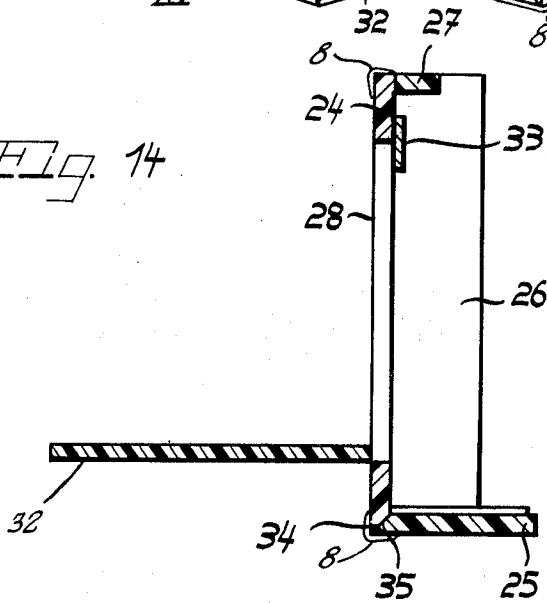

Fig. 15

INVENTOR

Günter Herms

BY

Walter Doherty

HOUSING FOR ROLLER BLINDS

The present invention relates to housing means for roller blinds and for sealing the masonry part receiving the roller blinds.

Housings or boxes for roller blinds are, as a rule, made of wood and serve for covering the hollow chamber in the concrete lintel of the door or window after the roller blind has been installed therein. In this connection it is unavoidable that cold air, dust and drafts enter said chamber through the gap so that it is generally useless to insulate the front wall blanket or apron which points toward the outside. It is far more important tightly and properly to insulate the inner box, which means the cover. This is of particular importance with large roller blinds because in such an instance the opening gap has to be wider because wide roller blinds often sag somewhat. When such roller blinds while being pulled up have each of their strips rub against the window frame, a disturbing loud noise results. Through the wider gap the draft air can still more easily enter into the above mentioned chamber.

It is, therefore, an object of the present invention to provide a roller blind box of a material which adapts itself positively to the window, the ceiling and the masonry and has a better insulating effect than thin wood.

It is another object of this invention to provide a box for roller blinds, which is simple in construction and can easily be manufactured.

These and other objects and advantages of the invention will appear more clearly from the following specification in connection with the accompanying drawings, in which:

FIG. 1 is a cross-section through a chamber in a window lintel with built-in roller blind box of the invention.

FIG. 1a is a top plan view which illustrates the bottom portion of a two-sectional roller blind box according to the invention.

FIG. 2 is an end elevation of FIG. 1a.

FIG. 3 shows a top view of the cover or top portion of a two-sectional roller blind box.

FIG. 4 is an end elevation of FIG. 3.

FIG. 5 is a perspective view of an angle profile for connecting the two roller box sections.

FIG. 6 is a perspective view of, a modification illustrating a one-piece roller blind box.

FIG. 7 represents a section taken along the line VII—VII of FIG. 6.

FIG. 8 is a perspective illustration of a partial section of a plate of foam material which is provided with rectangular grooves and serves for producing a one-piece roller blind box.

FIG. 9 is a section taken along the line IX—IX of FIG. 8 with the right-hand part (with regard to FIG. 8) folded upwardly.

FIG. 10 is a perspective illustration of a partial section of a plate of foam material in which the separating grooves include curved surface areas.

FIG. 11 is a section taken along the line XI—XI of FIG. 10 with the right-hand portion (with regard to FIG. 10) folded upwardly.

FIG. 12 is a perspective illustration of a partial section of a foam material plate in which the separating grooves are of a V-shaped contour.

FIG. 13 is a section through FIG. 12 taken along the line XIII—XIII thereof with the right-hand portion of FIG. 12 folded upwardly.

FIG. 14 is a perspective illustration of a roller blind box comprising more than two sections.

FIG. 15 is a section taken along the line XV—XV of FIG. 14.

The above outlined objects have been realized in conformity with the present invention which latter is characterized in that the roller blind box forms a prefabricated building block set of two coherent one-piece foam sections of synthetic material of which sections the bottom with the lateral surfaces forms one part or one section whereas the front cover with the roof forms the other part or section of the roller blind box.

Both sections are detachably interconnected by an angle rail or the like. As material for the parts making up the roller blind box are, in conformity with the present invention, preferred flexible medium to hard foams, for instance, on the basis of polystyrol, polyurethane, polyamide, phenol resin, polyethylene, etc. While attempts have been made to use polyvinylchloride plates for making roller blind boxes, such boxes become brittle after a relatively short time. In contrast thereto, the employed medium to hard foams are elastic to a great extent so that a better seal can be realized. Furthermore, the known synthetic foam material plates permit manufacturing processes which lead to a considerable simplification in the construction of roller blind boxes of the type involved. According to the embodiment of the present invention, only two main sections are necessary which consist of correspondingly cut hard foam plates and which by means of an angle rail or the like are detachably connected to each other. In conformity with the invention, one section of the roller blind box is punched out of a foam material plate, is sawed or milled in such a way that the bottom part or bottom section at the two narrow sides has an extension in the direction of the length of the box which corresponds to the height of the box with a double miter cut therebetween about which the two extensions can be folded upwardly and in this position form the lateral surfaces. Thus, there exist two possibilities of forming the said lateral surfaces of the roller blind box, depending on whether the construction is started from the bottom plate or from the cover plate. This assembly of the roller blind box in the manner of a carton by folding and upwardly bending the sections, while in view of the relative thickness of the foam material plates corresponding miter cuts are necessary, greatly simplifies the assembly of roller blind boxes and also reduces the manufacturing costs thereof.

According to a further development of the present invention, the foam material parts are covered by a foil of polyvinylchloride. It is advantageous in this connection that the foil covering the cover part protrudes at all four sides and that the protruding parts overlap those portions of the box which are adjacent thereto and form an angle of 90° therewith. In view of these steps, the butts of the roller blind sections are covered or overlapped so that the escape of draft air is effectively prevented. Furthermore, the total stiffness is increased by the applied polyvinylchloride foils so that a smooth outer surface will be obtained.

Furthermore, in conformity with the present invention, at the abutting areas of the bottom and cover section the connecting angle rail which covers the butt joint portion has its one smooth leg connected to one box part, for instance, by cementing, whereas the other leg is bent backwardly so as to form an arc which for purposes of forming a detachable closure snaps into a hook-shaped depression on the outside of the other box part.

This arrangement eliminates the awkward loosening of screws as it has heretofore been necessary for the connection of the two box parts or box sections with the angle profile. This improved construction forms an automatic resilient closure which greatly facilitates the handling when opening the cover.

For purposes of connecting the foil of the cover plate to the ceiling of the room, this foil is in conformity with the present invention so extended that it protrudes to a great extent while said protrusions are angle off by 90°.

Instead of the arrangement set forth in the preceding paragraph, it is also possible to connect the cover plate at that surface thereof which faces the ceiling with one leg of a profile of elastic material, such as rubber or synthetic material, whereas the other leg of said profile is connected to the ceiling of the room. In both instances, the elasticity of the foil connected to the ceiling permits an opening of the box portion cover by the foil so that the roller blind after loosening the angle rail connection is easily accessible and can also easily be closed again.

According to a further development of the invention, the roller blind box may also be so designed that all partial sur-

faces of the box form a single-piece coherent part of synthetic foam material which for defining the partial surfaces is provided with grooves from which the foam material has been removed with the exception of a cover layer over which the individual surface parts are folded toward each other so as to form a box.

Due to the fact that the roller blind box is formed by folding over the individual partial surfaces separated from each other by grooves and pertaining to a single synthetic form body, considerable advantages are obtained with regard to the manufacturing process which are reflected in a further decrease in the manufacturing costs for the roller blind box.

The grooves provided between the individual partial surfaces may, according to a further development of the invention, have plane and/or curved surfaces which in folded condition contact each other either completely or partially. According to a first possible embodiment, the groove surfaces may be plane and extend at an angle or parallel to each other. The groove surfaces may define an angle with each other of the magnitude of 90° and greater. In this way it will be assured that the individual partial surfaces can be folded over unimpededly so as to define a right angle with each other.

When the plane groove surfaces are parallel to each other, the parallel distance of two oppositely located plane groove surfaces equals at least the thickness of the foam material plate. This affords the possibility of supporting the folded part against that part of the box which is transverse thereto.

The oppositely located groove surfaces may, if desired, also be curved to such an extent that they end in a common line of intersection and that the outer arc of one groove surface corresponds to the inner arc of the other surface. In view of the complete or partial surface contact of the individual groove surfaces in folded condition of the partial surfaces of the single-piece foam material body, the sealing effect of the roller blind box against cold air and dust is greatly increased.

The two-sectional as well as the one-piece roller blind boxes according to the invention have proved highly satisfactory and no difficulties are encountered as to their manufacture. However, in order to develop a complete manufacturing and installation program, all partial surfaces of the box may be produced as individual parts separate from each other and may be made in the form of a synthetic foam body, and the areas where the individual partial surface are connected to each other may be made plane or curved so that in the said connecting area a right angled or an acute or obtuse angled adaptation and connection of the surfaces will be possible.

The assembly of the roller blind box from a plurality of individual parts has great advantages with regard to the packing process because small surface parts are obtained. This applies in particular when relatively large roller blind boxes are involved.

Referring now to the drawings in detail and FIGS. 1 to 5 thereof in particular, these figures show the individual parts of a two-sectional roller blind box according to the present invention. As will be seen from the drawings, the bottom section 1 has a connecting strip 2 and is furthermore provided with extensions 3 for forming the side or lateral surfaces, said extensions 3 being adapted to be folded about the double miter cuts 4. A foil 7 covers the foam material. As will be seen from FIG. 3, the foil 7 protrudes at both sides from the cover 5 at 6. Also the bottom 1 is covered with a foil 7. The bottom 1 and the cover 5 are interconnected by an angle rail 8 (FIG. 5) while screws are used as connecting means. The angle rail 8 extends over the cover foil 7 of both parts 1 and 5 and thus assures an absolutely tight seal. The connection of the cover 5 to the room ceiling may, however, also be effected to a wooden latch or strip previously attached to this area. There also exists the possibility of connecting the cover 5 to the room ceiling by connecting a rubber or soft polyvinylchloride profile on one hand to the room ceiling and on the other hand to the upper end of the cover 5. With this type of connection, the cover 5 can due to the elasticity of the profile material be easily folded or lifted.

According to the embodiment shown in FIG. 6, the roller blind box consists of a single plate of foam material. The bottom 9, the side surfaces 10 and the cover 11 are separated from each other by grooves 12. The embodiment illustrated in FIG. 6 has plane groove surfaces 13 which form an angle with each other. The individual surface parts are folded at the line of intersection 14 and thus form the box. The cover 11 of the roller blind box is formed by cuts made in the central portion of the plate, said cuts being effected along the lines 15, 16, 17 and 18 so that the cover 11 can be folded downwardly about the line 19 because along this line the foam material plate is cut through only up to the outer cover foil.

Instead of the plane groove surfaces 13 located at an angle with regard to each other, it is also possible, as indicated in FIGS. 8 and 9, to provide groove surfaces 20 which are parallel to each other. With this embodiment it is merely necessary that the parallel distance equals at least the thickness of the plate of foam material so that, as will be evident from FIG. 9, in folded condition a rectangular arrangement of the surface portions and even a support of the folded portion 21 on the transverse part 22 will be possible. This applies in particular to the side surfaces 10 which may rest against the bottom 9 of the roller blind box.

FIG. 10 illustrates that the separating grooves 12 may also have curved surfaces 23. FIG. 11 shows the arrangement of FIG. 10 in folded condition. FIG. 12 illustrates once more the angle shaped grooves disclosed in FIG. 6 but in unfolded condition with plane grooved surfaces defining an angle with each other. FIG. 13 shows the structure of FIG. 12 in folded condition.

The particular advantage of roller blind boxes as described above consists in that all partial surfaces form a part of a single foam material body, and the individual partial surfaces are separated from each other merely by grooves of a special shape and groove contour in such a way that a folding is possible in such a way that, as mentioned above, the individual groove surfaces contact each other either completely or partially. The employment of a plate of foam material as the basic structural element in combination with a folding of the partial surfaces to form a box-shaped structure similar to a folding carton will afford an assurance that the box will be dust-free and draft air-tight while on the other hand the manufacturing costs for such roller blind boxes are rather low.

Referring now to FIGS. 14 and 15, the roller blind box illustrated therein is composed of the individual members 24, 25, 26 and 27 which are connected to each other by gluing, cementing, screws or brackets or the like so as to form a box unit. The end face 24 of the box is within the area of the opening 28 cut open along the lines 29, 30 and 31 and thereby permits the folding out of the surface 32 forming the cover. For purposes of connecting the cover, the inner side is provided with a member 33 of wood or synthetic material.

It is, of course, to be understood that the present invention is, by no means, limited to the particular showing in the drawings but also comprises any modifications within the scope of the appended claims.

What I claim is:

1. In a building construction, in which a window opening is formed in a masonry wall with a window in said opening having a frame with a top member adjacent the top of said opening, and a recess in the inner side of said masonry wall above said top member and closed on its outer side, and in which a roller blind is mounted in said recess with the roller blind movable downwardly outside of said window, a roller blind housing closing and sealing said recess on the inner side of said wall comprising a structure having side and top walls in engagement with said masonry wall at the sides and top of said recess and a bottom wall extending into said recess to engage said top member of said frame, and a front wall closing the area between said top, bottom and side walls, each wall being formed with an inner surface layer of foam insulating material and with an outer surface of plastic foil, said inner surface layers of foam material having abutting edges to form a tight,

5

6

sealed joint to seal said recess by said housing, the front wall of said housing having an opening closed by a hinged panel having a foam inner surface layer.

2. In a building construction as claimed in claim 1, in which the plastic foil extends across the joints to form an air-tight seal.

3. In a building construction as claimed in claim 1, in which the said walls are made in a plurality of parts, and the joints between the parts are formed by extending the foil across the joint to seal the joint.

4. In a building construction as claimed in claim 1, in which said housing comprises two sections, the first section having interconnected bottom and side walls and the second section having a front wall with the hinged panel and the top wall.

5. In a building construction as claimed in claim 1, in which said foam insulating material is a flexible material selected

from the group consisting of polystyrol, polyurethane, polyamide, phenobresin and polyethylene foams.

6. In a building construction as claimed in claim 1, in which said housing is made in a plurality of sections forming said walls, and the joints between the sections include rail means overlapping the joints and detachably connected to at least one section.

7. In a building construction as claimed in claim 1, in which at least two of said walls are connected together by a single piece of foam material having an outer foil surface, said foam material of the inner surface layer being grooved along said joint so that the piece of material may be hinged by said foil and folded at right angles with the edges of said foam layer abutting.

* * * * *

20

25

30

35

40

45

50

55

60

65

70

75