



(51) International Patent Classification:

*H01M 4/94* (2006.01)     *H01M 8/1025* (2016.01)  
*H01M 4/86* (2006.01)     *H01M 8/1044* (2016.01)  
*H01M 8/10* (2016.01)

(63) Related by continuation (CON) or continuation-in-part (CIP) to earlier application:

US 15/148,085 (CON)  
Filed on 6 May 2016 (06.05.2016)

(21) International Application Number:

PCT/US2016/035040

(71) Applicant: IONIC MATERIALS, INC. [US/US]; 10-M Commerce Way, Woburn, MA 01801 (US).

(22) International Filing Date:

31 May 2016 (31.05.2016)

(72) Inventors: ZIMMERMAN, Michael, A.; 55 Rosemont Drive, No. Andover, MA 01845 (US). GAVRILOV, Alexei, B.; 4133 Inwood Drive, Woburn, MA 01801 (US). KELSEY, G., Stephen; 13 Baymeadow Drive, Nashua, NH 03063 (US). SMITH, Keith; 79 Butternut Lane, Methuen, MA 01844 (US).

(25) Filing Language:

English

(26) Publication Language:

English

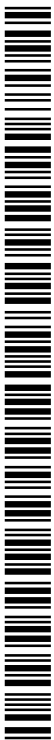
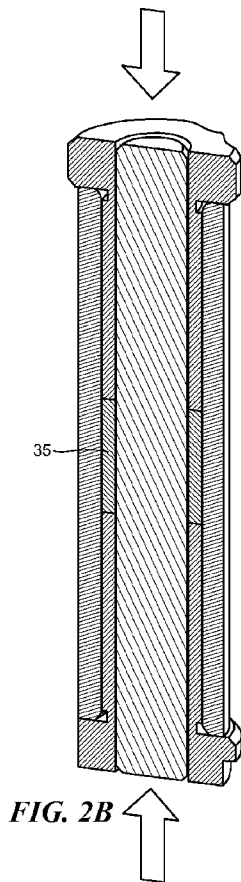
(30) Priority Data:

62/169,812     2 June 2015 (02.06.2015)     US  
15/148,085     6 May 2016 (06.05.2016)     US

[Continued on next page]

(54) Title: ALKALINE METAL-AIR BATTERY CATHODE

(57) Abstract: A metal-air battery and a component air cathode including a solid ionically conductive polymer material.



WO 2016/196477 A1



(74) **Agents:** SCHURGIN, Stanley, M. et al.; Preti Flaherty Beliveau & Pachios LLP, 60 State Street, Suite 1100, Boston, MA 02109 (US).

(81) **Designated States** (unless otherwise indicated, for every kind of national protection available): AE, AG, AL, AM, AO, AT, AU, AZ, BA, BB, BG, BH, BN, BR, BW, BY, BZ, CA, CH, CL, CN, CO, CR, CU, CZ, DE, DK, DM, DO, DZ, EC, EE, EG, ES, FI, GB, GD, GE, GH, GM, GT, HN, HR, HU, ID, IL, IN, IR, IS, JP, KE, KG, KN, KP, KR, KZ, LA, LC, LK, LR, LS, LU, LY, MA, MD, ME, MG, MK, MN, MW, MX, MY, MZ, NA, NG, NI, NO, NZ, OM, PA, PE, PG, PH, PL, PT, QA, RO, RS, RU, RW, SA, SC, SD, SE, SG, SK, SL, SM, ST, SV, SY, TH, TJ, TM, TN, TR, TT, TZ, UA, UG, US, UZ, VC, VN, ZA, ZM, ZW.

(84) **Designated States** (unless otherwise indicated, for every kind of regional protection available): ARIPO (BW, GH, GM, KE, LR, LS, MW, MZ, NA, RW, SD, SL, ST, SZ, TZ, UG, ZM, ZW), Eurasian (AM, AZ, BY, KG, KZ, RU,

TJ, TM), European (AL, AT, BE, BG, CH, CY, CZ, DE, DK, EE, ES, FI, FR, GB, GR, HR, HU, IE, IS, IT, LT, LU, LV, MC, MK, MT, NL, NO, PL, PT, RO, RS, SE, SI, SK, SM, TR), OAPI (BF, BJ, CF, CG, CI, CM, GA, GN, GQ, GW, KM, ML, MR, NE, SN, TD, TG).

**Declarations under Rule 4.17:**

- as to applicant's entitlement to apply for and be granted a patent (Rule 4.17(ii))
- as to the applicant's entitlement to claim the priority of the earlier application (Rule 4.17(iii))

**Published:**

- with international search report (Art. 21(3))
- before the expiration of the time limit for amending the claims and to be republished in the event of receipt of amendments (Rule 48.2(h))

**ALKALINE METAL-AIR BATTERY CATHODE****FIELD OF THE INVENTION**

The present invention generally relates to an electrochemical battery, and more particularly to a metal-air battery and its component cathode.

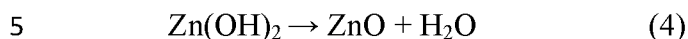
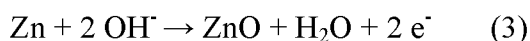
**BACKGROUND OF THE INVENTION**

A metal-air cell is an electrochemical cell that uses an anode made of a metal anode and oxygen from the air as a cathode depolarizer (fuel). Since oxygen is not stored in the cell, the capacity and energy density of metal-air cells can be very high. Specific energy for a zinc-air system and other metal air battery systems are shown in Table 1. The specific energy of zinc-air cells surpasses Li ion by a wide margin.

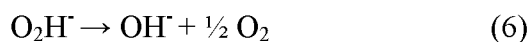
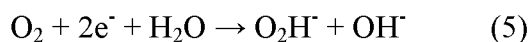
TABLE 1

Battery type	Theoretical specific energy, Wh/kg (including oxygen)	Theoretical specific energy, Wh/kg (excluding oxygen)	Open-circuit voltage, V
Aluminum-air	4300	8140	1.2
Calcium-air	2990	4180	3.12
Magnesium-air	2789	6462	2.93
Potassium-air	935	1700	2.48
Sodium-air	1677	2260	2.3
Lithium-air	5210	11140	2.91
Zinc-air	1090	1350	1.65
Lithium-ion battery	N/A	265	3.8

During discharge, the anode in a metal-air cell undergoes oxidation reactions typical for the particular metal. The reaction mechanism is usually multi-step, with intermediates depending on the electrolyte. Typical anode discharge reactions for alkaline zinc-air cell are represented by equations 1-4.



The critical component of all metal-air cells is the air electrode. Unlike traditional battery cathodes, the air electrode can function mostly as a catalytic matrix for oxygen reduction and also acts as cathode current collector, while oxygen is supplied from the air outside the battery which is usually atmospheric air. The cathode reaction sequence for alkaline aqueous electrolytes is described by the following equations:



15 Since oxygen is supplied from the outside air, the positive electrode itself can be very thin as it is needed only to conduct electrons and catalyze the oxygen to hydroxyl reaction. A variety of carbons, potassium permanganate, manganese dioxide, cobalt tetrapyrazinoporphyrazine derivatives, perovskites, titanium doped manganese dioxide, cobalt oxides, graphene, Ketjen Black, doped Ketjen black, carbon nanotubes, carbon fiber, cobalt manganese oxides, electrically conductive polymers and intrinsically conductive polymers, combinations thereof and other compounds have been reported to catalyze chemical decomposition of peroxides via reaction (6).

25 Typical air electrode cathode structures usually contain multiple layers, including an air diffusing layer, a hydrophobic PTFE layer, a catalytic layer where carbon is mixed with a catalyst which is active to improve peroxide decomposition. The cathode is separated from the anode by a separator and barrier layer, wettable to electrolyte, and capable of preventing the metal anode from direct contact with the cathode.

30 Air holes, facing the cathode, are used to provide adequate air supply. Before a metal-air cell is needed for use it must be protected from the external environment. An adhesive and gas differentiating tab covering the vent holes is used to prevent most of oxygen from freely entering the cell. The tab is removed prior to use to enable the cathode to freely air up.

Zinc-air cells are one of the most commonly used metal-air systems. The cell demonstrates higher energy density compared to alkaline cells. Disadvantages of this system include relatively low rate capability and susceptibility to environment conditions. Zinc-air cells typically perform well on low continuous current drains, but can provide insufficient service on intermittent and high rate tests.

Zinc-air cell construction is typically a coin cell design, which includes a bottom can with air holes, a cathode structure, including hydrophobic and barrier layers, on top of it, followed by separator. As the air electrode is thin, most of the cell volume is taken by zinc anode. Larger cells, typically in prismatic format, require a complicated air delivery system to sustain adequate performance. Cylindrical (e.g. AA or LR6 sized) zinc-air designs usually result in cell cost prohibitively high for the alkaline category, and require complicated cathode designs and manufacturing processes, air delivery paths and the need for welding a cathode current collector to the positive terminal assembly.

Typical primary zinc, manganese dioxide (“Zn/MnO<sub>2</sub>”) or alkaline batteries can provide good performance on variety of tests, including intermittent, with low material and manufacturing costs. However, battery capacity and hence service life is limited by amount of electrochemically active ingredients such as MnO<sub>2</sub> and zinc which can be packed into the cell.

In zinc-air and air assisted zinc-MnO<sub>2</sub> batteries the anode material and associated electrochemical reactions are essentially the same as for Zn/MnO<sub>2</sub>. However, in air assisted batteries, also known as air recovery or air restored batteries, the cathode can be recharged or restored by air. When the cell is not in use, or when the discharge rate is sufficiently low, atmospheric oxygen can enter the cell through the air holes and reacts with the air cathode, recharging manganese oxyhydrate back to dioxide:



At high discharge rates, an air assisted battery can operate like a conventional alkaline cell reducing fresh manganese dioxide. The cathode can be wetted with electrolyte for the MnO<sub>2</sub> reduction to occur. At the same time a typical cathode must enable oxygen ingress as oxygen has low solubility in KOH solutions.

Air assisted batteries are particularly useful in intermittent use applications and can provide substantial performance improvement compared to traditional alkaline batteries. However, design of the air assisted batteries is as complicated as that of zinc-air cells, making them difficult to manufacture and costly. Because of these limitations, no practical  
5 cylindrically shaped air assisted battery has been mass produced to date. Therefore, the need for low cost and easy to manufacture battery with improved run time in consumer applications is still unfulfilled, and there exists a need for a metal-air battery that can operate in intermittent and high rate use applications.

10

### SUMMARY OF THE INVENTION

According to an aspect, an electrochemical metal.-air battery with an air electrode component which comprises a solid ionically conducting polymer material, which is used in the air electrode and is referred to in this application as a solid ionically conducting polymer material..

15

In an aspect a metal-air battery comprising: an air electrode that include: an electrically conductive material, and a solid ionically conducting polymer material; a negative electrode comprising a first electrochemically active metal; and an ionically conducting, dielectric non-electrochemically active material interposed between the air electrode and the negative electrode and in contact with the air electrode, wherein the air  
20 electrode acts to reduce oxygen when the air electrode is exposed to an oxygen gas source and when the battery is under load.

Further aspects of the metal-air battery can include one or more of the following:

The solid ionically conducting polymer material has a crystallinity greater than 30%;

The solid ionically conducting polymer material has a melting temperature;

25

The solid ionically conducting polymer material has a glassy state;

The solid ionically conducting polymer material has both at least one cationic and anionic diffusing ion, wherein at least one diffusing ion is mobile in the glassy state;

The solid ionically conducting polymer material has a plurality of charge transfer complexes;

30

The solid ionically conducting polymer material comprises a plurality of monomers, and wherein each charge transfer complex is positioned on a monomer;

Electronic conductivity of the solid ionically conducting polymer material is less than  $1 \times 10^{-8}$  S/cm at room temperature;

The glassy state exists at temperatures below the melting temperature of the solid ionically conducting polymer material; at least one cationic diffusing ion comprises an alkali metal, an alkaline earth metal, a transition metal, or a post transition metal:

The solid ionically conducting polymer material comprises a plurality of monomers and wherein there is at least one anionic diffusing ion per monomer.

The solid ionically conducting polymer material comprises a plurality of monomers and wherein there is at least one cationic diffusing ion per monomer;

There is at least one mole of the cationic diffusing ion per liter of solid ionically conducting polymer material;

The charge transfer complex is formed by the reaction of a polymer, electron acceptor, and an ionic compound, wherein each cationic and anionic diffusing ion is a reaction product of the ionic compound;

The solid ionically conducting polymer material is formed from at least one ionic compound, wherein the ionic compound comprises each at least one cationic and anionic diffusing ion;

The solid ionically conducting polymer material is a thermoplastic.

The charge transfer complex is formed by the reaction of a polymer and an electron acceptor;

The melting temperature of the solid ionically conducting polymer material is greater than  $250^{\circ}\text{C}$ ;

Each at least one cationic and anionic diffusing ion have a diffusivity, wherein the cationic diffusivity is greater than the anionic diffusivity;

The cationic transference number of the solid ionically conducting polymer material is greater than 0.5;

The solid ionically conducting polymer material comprises lithium, and wherein the concentration of lithium is greater than 3 moles of lithium per liter of solid ionically conducting polymer material;

The cationic diffusing ion comprises lithium;

The diffusing cation is monovalent;

The valence of the diffusing cation is greater than one;

The air cathode produces hydroxide ion when it reduces oxygen, and wherein the solid ionically conducting polymer material ionically conducts hydroxide ion;

The diffusing anion is a hydroxide ion;

5 The diffusing anion is monovalent;

Both the diffusing anion and the diffusing cation are monovalent;

The at least one cationic and anionic diffusing ion have a diffusivity, wherein the anionic diffusivity is greater than the cationic diffusivity;

10 The cationic transference number of the solid ionically conducting polymer material is equal to or less than 0.5, and greater than zero;

The solid ionically conducting polymer material comprises a plurality of monomers, wherein each monomer comprises an aromatic or heterocyclic ring structure positioned in the backbone of the monomer;

15 The solid ionically conducting polymer material includes a heteroatom incorporated in the ring structure or positioned on the backbone adjacent to the ring structure and the heteroatom is selected from the group consisting of sulfur, oxygen or nitrogen;

A heteroatom is positioned on the backbone of the monomer adjacent the ring structure of the solid ionically conducting polymer material;

20 A heteroatom is positioned on the backbone of the monomer adjacent the ring structure of the solid ionically conducting polymer material, wherein the heteroatom is sulfur;

The solid ionically conducting polymer material is pi-conjugated;

The solid ionically conducting polymer material comprises a plurality of monomers, wherein the molecular weight of each monomer is greater than 100 grams/mole;

The solid ionically conducting polymer material is hydrophilic;

25 The ionic conductivity of solid ionically conducting polymer material is isotropic;

The solid ionically conducting polymer material is non-flammable;

The Young's modulus of the solid ionically conducting polymer material is equal to or greater than 3.0 MPa;

30 The solid ionically conducting polymer material becomes ionically conductive after being doped by an electron acceptor in the presence of an ionic compound that either contains

both a cationic and anionic diffusing ion or is convertible into both the cationic and anionic diffusing ion via oxidation by the electron acceptor;

The solid ionically conducting polymer material is formed from the reaction product of a base polymer, electron acceptor and an ionic compound, and wherein the base polymer  
5 can be a conjugated polymer, PPS or a liquid crystal polymer;

The air electrode further comprises a second electrochemically active material, which may comprise a metal oxide, which may be manganese dioxide;

The first electrochemically active material comprises zinc;

The first electrochemically active material comprises zinc, aluminum, calcium,  
10 magnesium, potassium, sodium or lithium;

The air electrode further comprises a second electrochemically active material, wherein the second electrochemically active material is intermixed with the electrically conductive material and the solid ionically conductive polymer material;

The ionically conducting, dielectric non-electrochemically active material comprises  
15 both a nonwoven separator disposed adjacent the air electrode and an aqueous electrolyte;

The electrically conductive material comprises carbon;

The battery is non-aqueous and the ionically conducting, dielectric non-electrochemically active material comprises solid ionically conducting polymer material;

The ionically conducting, dielectric non-electrochemically active material comprises  
20 both a nonwoven separator disposed adjacent the air electrode and an aqueous electrolyte;

The electrically conductive material is mixed with the solid ionically conducting polymer material and wherein the air electrode is thermoplastic; and

The oxygen gas source is an air source, wherein the air source includes a first concentration of oxygen, carbon dioxide and water vapor gas, wherein the battery further  
25 comprises an air differentiation system fluidly interposed between the air electrode and the air source, and wherein the air differentiation system supplies the air electrode with a second concentration of oxygen, carbon dioxide and water vapor gas, and wherein the air differentiation system affects the concentration of oxygen reaching the air electrode when battery is under load, such that the second concentration of oxygen is greater than the first  
30 concentration of oxygen, wherein the air differentiation system affects the concentration of carbon dioxide, wherein the second concentration of carbon dioxide is less than the first

concentration of carbon dioxide, wherein the air differentiation system affects the concentration of water, wherein the second concentration of water is less than the first concentration of water, wherein the air differentiation system comprises the solid ionically conducting polymer material, or wherein the air source is atmospheric air and wherein the battery is disposed within an enclosure having an air supply port, wherein the air supply port allows atmospheric air to flow to the air electrode.

An aspect and object of the battery is the ionic mobility provided by the solid ionically conducting polymer material, specifically:

The ionic conductivity of the solid ionically conducting polymer material is greater than  $1.0 \times 10^{-5}$  S/cm at room temperature;

The solid ionically conducting polymer material comprises a single cationic diffusing ion, wherein the diffusivity of the cationic diffusing ion is greater than  $1.0 \times 10^{-12}$  m<sup>2</sup>/s at room temperature;

The solid ionically conducting polymer material comprises a single anionic diffusing ion, wherein the diffusivity of the anionic diffusing ion is greater than  $1.0 \times 10^{-12}$  m<sup>2</sup>/s at room temperature;

The solid ionically conducting polymer material, wherein one of the at least cationic diffusing ion, has a diffusivity greater than  $1.0 \times 10^{-12}$  m<sup>2</sup>/s;

The solid ionically conducting polymer material, wherein one of the at least one anionic diffusing ion has a diffusivity greater than  $1.0 \times 10^{-12}$  m<sup>2</sup>/s;

The solid ionically conducting polymer material, wherein one of both the at least one anionic diffusing ion and at least one cationic diffusing ion has a diffusivity greater than  $1.0 \times 10^{-12}$  m<sup>2</sup>/s;

The solid ionically conducting polymer material has an ionic conductivity greater than  $1 \times 10^{-4}$  S/cm at room temperature;

The solid ionically conducting polymer material has an ionic conductivity greater than  $1 \times 10^{-3}$  S/cm at 80°C;

The solid ionically conducting polymer material has an ionic conductivity greater than  $1 \times 10^{-5}$  S/cm at -40°C; and

The cationic diffusing ion comprises lithium, and wherein the diffusivity of lithium ion and the hydroxide ion are both greater than  $1.0 \times 10^{-13}$  m<sup>2</sup>/s at room temperature.

In an aspect, the battery can be composed with one or more of the following attributes:

The electrically conducting material comprises 10-30 percent by weight of the air electrode;

5 The solid ionically conducting polymer material comprises 5-50 percent by weight of the air electrode;

The second electrochemically active material comprises 10-70 percent by weight of the air electrode;

10 The air cathode comprises an oxygen reduction catalyst, which can be selected from a group comprising carbons, potassium permanganate, manganese dioxide, cobalt tetrapyrazinoporphyrazine derivatives, perovskites, titanium doped manganese dioxide, cobalt oxides, graphene, Ketjen Black, doped Ketjen black, carbon nanotubes, carbon fiber, cobalt manganese oxides, electrically conductive polymers and intrinsically conductive polymers, and combinations thereof;

15 The air electrode comprises manganese dioxide, and the manganese dioxide is selected from a group comprising  $\beta$ -MnO<sub>2</sub> (pyrolusite), ramsdellite,  $\gamma$ -MnO<sub>2</sub>,  $\epsilon$ -MnO<sub>2</sub>,  $\lambda$ -MnO<sub>2</sub>, EMD, CMD, and combinations thereof;

The electrically conductive material comprises carbon, and the ratio of weight of manganese dioxide to weight of carbon is greater than 2:1;

20 The first electrochemically active material comprises zinc, and wherein the ratio of weight of zinc to weight of manganese dioxide is greater than 1:1;

The ratio of weight of manganese dioxide to weight of ionically conducting polymer material in the air electrode is greater than 1:1;

25 The metal-air battery further comprises a metal can which acts as the positive current collector, wherein the air electrode is in electrical communication with the can;

The can is cylindrical, and the air cathode is annularly shaped;

The can is AA (LR6) sized; and

The oxygen gas permeability of the solid ionically conducting polymer material is greater than its water permeability; and

30 An AA sized cell comprising the air electrode containing the solid ionically conducting polymer material demonstrated greater than 3Ah capacity during: Continuous

constant current discharge at current between 150 and 300 mA with 0.8 V voltage cutoff; Intermittent discharge at current between 150 and 300 mA cutoff applied for 1 hour, followed by 1-hour rest period (0.8V voltage cutoff; Continuous constant current discharge at 50 mA to 1.0V voltage cutoff; Intermittent discharge at 50 mA with applied for 1 hour, followed by  
5 1-hour rest period (1.0 voltage cutoff); Continuous constant resistance discharge at 3.9 Ohm to 0.8V voltage cutoff; Intermittent constant resistance discharge when 3.9 Ohm resistance is applied for 1 hour, followed by 1-hour rest period (0.8V voltage cutoff); Continuous constant resistance discharge of at 42 Ohm to 1.0 voltage cutoff; and Intermittent constant resistance discharge when 42 Ohm resistance is applied for 15 seconds, followed by 45-second rest  
10 period (1.0V voltage cutoff)..

In an aspect, a method of manufacturing an air electrode can comprise one or more of the following steps:

Mixing a polymer with an ionic compound and an electron acceptor to create a first mixture;

15 Heating the first mixture to form, the first mixture into solid ionically conducting polymer material;

Mixing the solid ionically conducting polymer material with an electrically conductive material to make a second mixture which is reactive to reduce oxygen and ionically conduct hydroxyl ions.

20 In an aspect, a method of manufacturing an air electrode can further comprise one or more of the following steps in combination with the previous aspect:

In the second mixture mixing step a codepolarizer is added to the second mixture; The codepolarizer is manganese dioxide.

In the first mixing step a codepolarizer is added to the first mixture.

25 The electrically conductive material comprises carbon.

A forming step is used, wherein the second mixture is formed into the air cathode.

In the forming step pressure is applied to the second mixture to thermoform the second mixture into an air cathode, wherein the air cathode is formed into a film, or wherein the air cathode is formed into an annulus;

30 The base polymer is PPS, PEEK, LCP, PPy, or a combination thereof;

The dopant is selected from DDQ, TCNE, chloranil, SO<sub>3</sub>, ozone, a transition metal oxide, MnO<sub>2</sub>, oxygen and air;

The ionic compound is a salt, hydroxide, oxide or other material containing hydroxide ions or convertible to hydroxide;

5 The ionic compound comprises LiOH, NaOH, KOH, Li<sub>2</sub>O, or LiNO<sub>3</sub>;

In the heating step the first mixture is heated to a temperature between 250 and 450 deg. C;

In the heating step, pressure is applied to the first mixture while it is being heated, and the pressure can be between 300 and 500 psi;

10 In the second mixture step the manganese dioxide is encapsulated by solid ionically conducting polymer material;

In the forming step the air electrode is extruded;

In the second mixture mixing step a catalyst is added to the mixture;

In the second mixture mixing step a hydrophobic compound is added to the mixture;

15 In the second mixture mixing step a carbon dioxide adsorbing compound is added to the mixture; and

A locating step is used to position the air cathode within a can and adjacent an inner surface of the can, wherein the air cathode can be shaped as an annulus, and wherein a second annulus shaped cathode portion can be located adjacent to both the inner surface of the can and the air cathode, and wherein the second cathode portion can comprise or can be free of  
20 the solid ionically conducting polymer material.

These and other features, advantages, and objects will be further understood and appreciated by those skilled in the art by reference to the following specification, claims, and appended drawings.

25

### BRIEF DESCRIPTION OF THE DRAWINGS

In the drawings:

5 FIG. 1 is a discharge curve showing cell performance using four different electrically conductive carbons;

FIG. 2A is a cross-sectional representational view of a tool for preparing cathode sections;

10 FIG. 2B is a cross-sectional representational view of air cathode annular sections being formed by a tool;

FIG. 3 is a cross sectional view of an electrochemical battery cell;

FIG. 4 is a discharge curve of a cell and comparative cells under continuous 150 mA discharge;

15 FIG. 5 is a discharge curve described in Example 7 showing intermittent discharge voltage of the Example 7 cell and comparative commercial cells as a function of test time;

FIG. 6 is a discharge curve described in Example 8 showing intermittent discharge as a function of test time.;

FIG. 7 is a volumetric normalized curve described in Example 9 showing a comparison of volumetric capacity rate per volume profiles for various technologies;

20 FIG. 8 is a cross-sectional representative view of an aspect of the invention showing a thin film battery.

### DETAILED DESCRIPTION OF THE PREFERRED EMBODIMENTS

The present patent application claims priority from U.S. Provisional Patent  
25 Application No.: 62/169,812, filed June 2, 2015; and is a Continuation-In-Part application of U.S. Patent Application No.: 15/148,085, filed May 6, 2016 which (a) claims priority from U.S. Patent Application No.: 15/148,085, filed May 6, 2016 which (a) claims priority from U.S. Provisional Patent Application No.: 62/158,841, filed May 8, 2015 and (b) is a Continuation-In-Part application of both (i) U.S. Patent Application No.: 14/559,430, filed  
30 December 3, 2014, which claims priority from U.S. Provisional Patent Application No.: 61/911,049, filed December 3, 2013; and (ii) from U.S. Patent Application No.: 13/861,170, filed April 11, 2013, which claims priority from U.S. Provisional Patent Application

No.: 61/622,705, filed April 11, 2012, the disclosures of which are incorporated by reference herein in their entirety.

The following explanations of terms are provided to better detail the descriptions of aspects, embodiments and objects that will be set forth in this section. Unless explained or defined otherwise, all technical and scientific terms used herein have the same meaning as commonly understood to one of ordinary skill in the art to which this disclosure belongs. In order to facilitate review of the various embodiments of the disclosure, the following explanations of specific terms are provided:

A depolarizer is a synonym of electrochemically active substance, i.e., a substance which changes its oxidation state, or partakes in a formation or breaking of chemical bonds, in a charge-transfer step of an electrochemical reaction and electrochemically active material. When an electrode has more than one electroactive substances they can be referred to as codepolarizers.

Thermoplastic is a characteristic of a plastic material or polymer to become pliable or moldable above a specific temperature often around or at its melting temperature and to solidify upon cooling.

Solid electrolytes include solvent free polymers, and ceramic compounds (crystalline and glasses).

A "Solid" is characterized by the ability to keep its shape over an indefinitely long period, and is distinguished and different from a material in a liquid phase. The atomic structure of solids can be either crystalline or amorphous. Solids can be mixed with or be components in composition structures.

For purposes of this application and its claims, a solid ionically conducting polymer material requires that that material be ionically conductive through the solid and not through any solvent, gel or liquid phase, unless it is otherwise described. For purposes of this application and its claims, gelled (or wet) polymers and other materials dependent on liquids for ionic conductivity are defined as not being solid electrolytes (solid ionically conducting polymer material) in that they rely on a liquid phase for their ionic conductivity.

A polymer is typically organic and comprised of carbon based macromolecules, each of which have one or more type of repeating units or monomers. Polymers are light-weight, ductile, usually non-conductive and melt at relatively low temperatures. Polymers can be

made into products by injection, blow and other molding processes, extrusion, pressing, stamping, three dimensional printing, machining and other plastic processes. Polymers typically have a glassy state at temperatures below the glass transition temperature  $T_g$ . This glass temperature is a function of chain flexibility, and occurs when there is enough  
5 vibrational (thermal) energy in the system to create sufficient free-volume to permit sequences of segments of the polymer macromolecule to move together as a unit. However, in the glassy state of a polymer, there is no segmental motion of the polymer.

Polymers are distinguished from ceramics which are defined as inorganic, non-metallic materials; typically compounds consisting of metals covalently bonded to oxygen,  
10 nitrogen or carbon, brittle, strong and non-conducting.

The glass transition, which occurs in some polymers, is a midpoint temperature between the supercooled liquid state and a glassy state as a polymer material is cooled. The thermodynamic measurements of the glass transition are done by measuring a physical  
15 property of the polymer, e.g. volume, enthalpy or entropy and other derivative properties as a function of temperature. The glass transition temperature is observed on such a plot as a break in the selected property (volume or enthalpy) or from a change in slope (heat capacity or thermal expansion coefficient) at the transition temperature. Upon cooling a polymer from above the  $T_g$  to below the  $T_g$ , the polymer molecular mobility slows down until the polymer reaches its glassy state.

As a polymer can comprise both amorphous and crystalline phase, polymer  
20 crystallinity is the amount of this crystalline phase relative the amount of the polymer and is represented as a percentage. Crystallinity percentage can be calculated via x-ray diffraction of the polymer by analysis of the relative areas of the amorphous and crystalline phases.

A polymer film is generally described as a thin portion of polymer, but should be  
25 understood as equal to or less than 300 micrometers thick.

It is important to note that the ionic conductivity is different from electrical  
conductivity. Ionic conductivity depends on ionic diffusivity, and the properties are related by the Nernst-Einstein equation. Ionic conductivity and ionic diffusivity are both measures of  
30 ionic mobility. An ionic is mobile in a material if its diffusivity in the material is positive (greater than zero), or it contributes to a positive conductivity. All such ionic mobility measurements are taken at room temperature (around 21°C), unless otherwise stated. As ionic

mobility is affected by temperature, it can be difficult to detect at low temperatures.

Equipment detection limits can be a factor in determining small mobility amounts. Mobility can be understood as diffusivity of an ion at least  $1 \times 10^{-14}$  m<sup>2</sup>/s and preferably at least  $1 \times 10^{-13}$  m<sup>2</sup>/s, which both communicate an ion is mobile in a material.

5           A solid polymer ionically conducting material is a solid that comprises a polymer and that conducts ions as will be further described.

          An aspect includes a method of synthesizing a solid ionically conducting polymer material from at least three distinct components: a polymer, a dopant and an ionic compound. The components and method of synthesis are chosen for the particular application of the  
10           material. The selection of the polymer, dopant and ionic compound may also vary based on the desired performance of the material. For example, the desired components and method of synthesis may be determined by optimization of a desired physical characteristic (e.g. ionic conductivity).

15           Synthesis:

          The method of synthesis can also vary depending on the particular components and the desired form of the end material (e.g. film, particulate, etc.). However, the method includes the basic steps of mixing at least two of the components initially, adding the third component in an optional second mixing step, and heating the components/reactants to  
20           synthesizes the solid ionically conducting polymer material in a heating step. In one aspect of the invention, the resulting mixture can be optionally formed into a film of desired size. If the dopant was not present in the mixture produced in the first step, then it can be subsequently added to the mixture while heat and optionally pressure (positive pressure or vacuum) are applied. All three components can be present and mixed and heated to complete the synthesis  
25           of the solid ionically conducting polymer material in a single step. However, this heating step can be done when in a separate step from any mixing or can be completed while mixing is being done. The heating step can be performed regardless of the form of the mixture (e.g. film, particulate, etc.) In an aspect of the synthesis method, all three components are mixed and then extruded into a film. The film is heated to complete the synthesis.

30           When the solid ionically conducting polymer material is synthesized, a color change occurs which can be visually observed as the reactants color is a relatively light color, and the solid ionically conducting polymer material is a relatively dark or black color. It is believed

that this color change occurs as charge transfer complexes are being formed, and can occur gradually or quickly depending on the synthesis method.

An aspect of the method of synthesis is mixing the base polymer, ionic compound and dopant together and heating the mixture in a second step. As the dopant can be in the gas phase, the heating step can be performed in the presence of the dopant. The mixing step can be performed in an extruder, blender, mill or other equipment typical of plastic processing. The heating step can last several hours (e.g. twenty-four (24) hours) and the color change is a reliable indication that synthesis is complete or partially complete.

In an aspect of the synthesis method, the base polymer and ionic compound can be first mixed. The dopant is then mixed with the polymer-ionic compound mixture and heated. The heating can be applied to the mixture during the second mixture step or subsequent to the mixing step.

In another aspect of the synthesis method, the base polymer and the dopant are first mixed, and then heated. This heating step can be applied after the mixing or during, and produces a color change indicating the formation of the charge transfer complexes and the reaction between the dopant and the base polymer. The ionic compound is then mixed to the reacted polymer dopant material to complete the formation of the solid ionically conducting polymer material.

Typical methods of adding the dopant are known to those skilled in the art and can include vapor doping of film containing the base polymer and ionic compound and other doping methods known to those skilled in the art. Upon doping the solid polymer material becomes ionically conductive, and it is believed that the doping acts to activate the ionic components of the solid polymer material so they are diffusing ions.

Other non-reactive components can be added to the above described mixtures during the initial mixing steps, secondary mixing steps or mixing steps subsequent to heating. Such other components include but are not limited to depolarizers or electrochemically active materials such as anode or cathode active materials, electrically conductive materials such as carbons, rheological agents such as binders or extrusion aids (e.g. ethylene propylene diene monomer "EPDM"), catalysts and other components useful to achieve the desired physical properties of the mixture.

Polymers that are useful as reactants in the synthesis of the solid ionically conducting polymer material are electron donors or polymers which can be oxidized by electron acceptors. Semi-crystalline polymers with a crystallinity index greater than 30%, and greater than 50% are suitable reactant polymers. Totally crystalline polymer materials such as liquid  
5 crystal polymers (“LCPs”) are also useful as reactant polymers. LCPs are totally crystalline and therefore their crystallinity index is hereby defined as 100%. Undoped conjugated polymers and polymers such as polyphenylene sulfide (“PPS”) are also suitable polymer reactants.

Polymers are typically not electrically conductive. For example, virgin PPS has  
10 electrical conductivity of  $10^{-20}$  S cm<sup>-1</sup>. Non-electrically conductive polymers are suitable reactant polymers.

In an aspect, polymers useful as reactants can possess an aromatic or heterocyclic component in the backbone of each repeating monomer group, and a heteroatom either incorporated in the heterocyclic ring or positioned along the backbone in a position adjacent  
15 the aromatic ring. The heteroatom can be located directly on the backbone or bonded to a carbon atom which is positioned directly on the backbone. In both cases where the heteroatom is located on the backbone or bonded to a carbon atom positioned on the backbone, the backbone atom is positioned on the backbone adjacent to an aromatic ring. Non-limiting examples of the polymers used in this aspect of the invention can be selected  
20 from the group including PPS, Poly(p-phenylene oxide)(“PPO”), LCPs, Polyether ether ketone (“PEEK”), Polyphthalamide (“PPA”), Polypyrrole, Polyaniline, and Polysulfone. Copolymers including monomers of the listed polymers and mixtures of these polymers may also be used. For example, copolymers of p-hydroxybenzoic acid can be appropriate liquid crystal polymer base polymers.

25 Table 2 details non-limiting examples of reactant polymers useful in the synthesis of the solid ionically conducting polymer material along with monomer structure and some physical property information which should be considered also non-limiting as polymers can take multiple forms which can affect their physical properties.

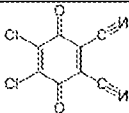
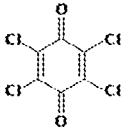
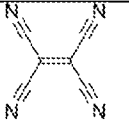
TABLE 2

Polymer	Monomer Structure	Melting Pt.(C)	MW
PPS polyphenylene sulfide		285	109
PPO Poly( <i>p</i> -phenylene oxide)		262	92
PEEK Polyether ether ketone		335	288
PPA Polyphthalamide		312	
Polypyrrole			
Polyaniline Poly- Phenylamine [C <sub>6</sub> H <sub>4</sub> NH] <sub>n</sub>		385	442
Polysulfone			240
Xydar (LCP)			
Vectran Poly-paraphenylene terephthalamide [-CO-C <sub>6</sub> H <sub>4</sub> -CO-NH-C <sub>6</sub> H <sub>4</sub> -NH-] <sub>n</sub>			
Polyvinylidene fluoride (PVDF)		177 °C	
Polyacrylonitrile (PAN)		300 °C	
Polytetrafluoro-ethylene (PTFE)		327	
Polyethylene (PE)		115-135	

Dopants that are useful as reactants in the synthesis of the solid ionically conducting polymer material are electron acceptors or oxidants. It is believed that the dopant acts to release ions for ionic transport and mobility, and it is believed to create a site analogous to a

charge transfer complex or site within the polymer to allow for ionic conductivity. Non-limiting examples of useful dopants are quinones such as: 2,3-dicyano-5,6-dichlorodicyanoquinone ( $C_8Cl_2N_2O_2$ ) also known as “DDQ”, and tetrachloro-1,4-benzoquinone ( $C_6Cl_4O_2$ ), also known as chloranil, tetracyanoethylene ( $C_6N_4$ ) also known as TCNE, sulfur trioxide (“ $SO_3$ ”), ozone (trioxygen or  $O_3$ ), oxygen ( $O_2$ , including air), transition metal oxides including manganese dioxide (“ $MnO_2$ ”), or any suitable electron acceptor, etc. and combinations thereof. Dopants that are temperature stable at the temperatures of the synthesis heating step are useful, and quinones and other dopants which are both temperature stable and strong oxidizers quinones are very useful. Table 3 provides a non-limiting listing of dopants, along with their chemical diagrams.

TABLE 3

Dopant	Formula	Structure
2,3-Dichloro-5,6-dicyano-1,4-benzoquinone (DDQ)	$C_8Cl_2(CN)_2O_2$	
tetrachloro-1,4-benzoquinone (chloranil)	$C_6Cl_4O_2$	
Tetracyanoethylene (TCNE)	$C_6N_4$	
Sulfur Trioxide	$SO_3$	
Ozone	$O_3$	
Oxygen	$O_2$	
Transition Metal Oxides	$MxO_y$ (M=Transition Metal, x and y are equal to or greater than 1)	

Ionic compounds that are useful as reactants in the synthesis of the solid ionically conducting polymer material are compounds that release desired ions during the synthesis of the solid ionically conducting polymer material. The ionic compound is distinct from the dopant in that both an ionic compound and a dopant are required. Non-limiting examples include  $Li_2O$ ,  $LiOH$ ,  $NaOH$ ,  $KOH$ ,  $LiNO_3$ ,  $Na_2O$ ,  $MgO$ ,  $CaCl_2$ ,  $MgCl_2$ ,  $AlCl_3$ , LiTFSI (lithium bis-trifluoromethanesulfonimide), LiFSI (Lithium bis(fluorosulfonyl)imide), Lithium bis(oxalato)borate ( $LiB(C_2O_4)_2$  “LiBOB”) and other lithium salts and combinations

thereof. Hydrated forms (e.g. monohydrate) of these compounds can be used to simplify handling of the compounds. Inorganic oxides, chlorides and hydroxide are suitable ionic compounds in that they dissociate during synthesis to create at least one anionic and cationic diffusing ion. Any such ionic compound that dissociates to create at least one anionic and cationic diffusing ion would similarly be suitable. Multiple ionic compounds can also be useful that result in multiple anionic and cationic diffusing ions can be preferred. The particular ionic compound included in the synthesis depends on the utility desired for the material. For example, in an application where it would be desired to have a hydroxide anion, a lithium hydroxide, or an oxide convertible to a hydroxide ion would be appropriate. As would be any hydroxide containing compound that releases a diffusing anion during synthesis. A non-limiting group of such hydroxide ionic compounds includes metals. The hydroxide ionic compounds can include alkaline metals, alkaline earth metals, transition metals, and post transition metals in a form that can produce both the desired cationic and anionic diffusing species are appropriate as synthesis reactant ionic compounds.

The purity of the materials is potentially important so as to prevent any unintended side reactions and to maximize the effectiveness of the synthesis reaction to produce a highly conductive material. Substantially pure reactants with generally high purities of the dopant, base polymer and the ionic compound are useful, and purities greater than 98% are more useful with even higher purities, e.g. LiOH: 99.6%, DDQ: >98%, and Chloranil: >99% also useful.

To further describe the utility of the solid ionically conductive polymer material and the versatility of the above described method of the synthesis of the solid ionically conducting polymer material, several classes of the solid ionically conducting polymer material useful for multiple electrochemical applications and distinguished by their application are described:

#### Example 1

PPS polymer was mixed with the ionic compound LiOH monohydrate in the proportion of 67% to 33% (by wt.), respectively, and mixed using jet milling. This undoped mixture can be extruded into a film or other shape prior to doping. A portion is extruded into

a film to create an undoped film (of PPS and LiOH). DDQ dopant was added via vapor doping to the resulting mixture at a temperature between 250 and

325 °C for 30 minutes under moderate pressure (500-1000 PSI) to synthesize a solid ionically conducting polymer material (PPS/LiOH/DDQ). In an aspect, the solid ionically  
 5 conducting polymer material PPS/LiOH/DDQ is synthesized in a particulate form by first mixing the DDQ dopant and base polymer PPS monomer. The ionic compound LiOH is added and the three component mixtures is heated between 250 and 325 °C to create the particulate form.

Electronic conductivity was measured using the potentiostatic method between  
 10 blocking electrodes, and was determined to be about  $6.5 \times 10^{-9}$  S/cm (less than  $1 \times 10^{-8}$  S/cm).

Ionic diffusivity measurements were conducted on a compression molded particulate form of the PPS/LiOH/DDQ material using fundamental NMR techniques. Specifically, the diffusivity of lithium and hydroxide ions was evaluated by a pulsed gradient spin echo (“PGSE”) lithium NMR method. The PGSE-NMR measurements were made using a Varian-  
 15 S Direct Drive 300 (7.1 T) spectrometer. The solid polymer ionically conducting material, has a  $\text{Li}^+$  diffusivity of  $5.7 \times 10^{-11}$  m<sup>2</sup>/s at room temperature, and the diffusivity of the OH<sup>-</sup> ion was  $4.1 \times 10^{-11}$  m<sup>2</sup>/s at room temperature. These diffusivity values can be used to calculate both an anionic and cationic transference number. Although related, the anionic transference number is more relevant in that the diffusivity of the hydroxide is important in alkaline  
 20 batteries.

After synthesis, the solid ionically conducting polymer material film of 20 micron thickness was tested for air component permeability (i.e. oxygen, water, and carbon dioxide) at room temperature. The permeability of the solid ionically conducting polymer material film, and undoped film (also 20 microns in thickness) was compared against Zitex G-104  
 25 film from Saint-Gobain, (100 microns thick). and the results are detailed in Table 4 which details permeability results in units of moles gas/cm<sup>2</sup>-sec.

TABLE 4

Gas	Undoped Film	Example 1 Film	Zitex
Oxygen (O <sub>2</sub> )	$2.1 \times 10^{-9}$	$1 \times 10^{-8}$	$2.1 \times 10^{-6}$
Water (H <sub>2</sub> O)	0	$1.3 \times 10^{-8}$	$1.5 \times 10^{-8}$
Carbon Dioxide (CO <sub>2</sub> )	0	$1.4 \times 10^{-10}$	$\times 10^{-10}$

Doping results in a significant change in the permeability properties solid polymer film. The synthesized solid polymer film shows some gas differentiating properties, and its oxygen permeability is important and can be contrasted relative its lower carbon dioxide permeability. The undoped polymer film, is impermeable relative both water and CO<sub>2</sub>. In an aspect, a combination of a doped and undoped solid polymer film can provide water and carbon dioxide impermeability in a gas differentiation system.

#### Zinc-Air Battery:

The solid ionically conducting polymer material, which can be produced using high volume manufacturing processes, has applicability in metal-air cells. An aspect is an air cathode based on the solid ionically conducting polymer material and a metal-air cell comprising the air cathode.

The air cathode simplifies prior art metal-air cathodes by using a single layer comprising electrically conducting carbon powder intermixed with the solid ionically conducting polymer material. The electrically conductive carbon can be in the form of graphite, carbon black, graphenes, electrically conductive polymers, or mixtures thereof.

In an aspect, additional catalyst is added to the air electrode. Although the combination of the solid ionically conducting polymer material and the electrically conductive carbon powder provides sufficient catalytic rate capability, potassium permanganate, manganese dioxide, cobalt tetrapyrazinoporphyrazine derivatives, perovskites and other compounds are useful to further catalyze chemical decomposition of peroxides and thus can be optionally added.

#### Example 2

An air cathode is made by mixing the solid ionically conductive polymer material prepared in Example 1 with electrically conductive carbon powder in desired proportion and compression-molded onto an electrically conducting (e.g. metal) current collector which is electrically connected to a positive terminal of the cell.

Air electrodes were prepared by mixing the solid ionically conducting polymer material with variety of carbons: TIMCAL SUPER C45 Conductive Carbon Black (C45), Timcal SFG6 (synthetic graphite), A5303 carbon black from Ashbury and natural vein

graphite nano 99 from Ashbury (N99). Carbon content was varied from 15 to 25% wt.%. Cathodes were punched to fit a 2032 coin cell. Zinc foil was used as the anode. Non-woven separator was soaked with aqueous 40% KOH solution. Two holes were drilled in the coin top facing the cathode. Cells were discharged at room temperature using a MTI coin cell tester at a 0.5 mA constant current.

Cathode parameters and test results are summarized in Table 5. Discharge curves are shown at FIG. 1. The cells with the air cathode demonstrate typical for Zn-air cells discharge behavior without any traditional catalyst (e.g. transition metal based) added to the mixture.

TABLE 5

Cathode #	Carbon	C%	T (mil)	Wt (mg)	g/cc	OCV (V)	mAh
1	C45	15%	23.3	102.7	0.553	1.2667	5.628
2	N99	25%	25.3	137.8	0.757	1.3343	4.742
3	A5303	20%	21.5	116.8	0.755	1.3405	7.864
4	SFG6	25%	29.2	166.3	0.791	1.3185	6.539

Air Assisted Zinc - MnO<sub>2</sub> battery:

In an air assisted zinc-manganese dioxide battery a second depolarizer or electrochemically active cathode material can be added in the form of  $\beta$ -MnO<sub>2</sub> (pyrolusite), ramsdellite,  $\gamma$ -MnO<sub>2</sub>,  $\epsilon$ -MnO<sub>2</sub>,  $\lambda$ -MnO<sub>2</sub> and other MnO<sub>2</sub> phases or mixtures thereof, including, but not limited to, EMD and CMD. Although this Example is limited to an air assisted Zinc- MnO<sub>2</sub> system, other depolarizers can be added in other metal air systems. Such second depolarizers are added in the range of 30-70 wt.%.

Electrically conductive carbons such as the carbons listed in Example 2 are useful as are other electrically conductive carbons such as Ketjenblack EC-600 JD, and other conductive additives typical and known in the battery field. Such electrically conductive carbons are added in the range of 10-60 wt. %.

The solid ionically polymer material can be prepared independently or prepared during the preparation of the air cathode. In an aspect, the reactant polymer and the ionic compound are mixed with air and then heated to make the solid ionically conducting polymer material. In another aspect, the reactant polymer and the ionic compound are mixed with

EMD or other depolarizer and then heated to make the solid ionically conducting polymer material. During heating, the mixture undergoes a color change indicating its reaction and transition into an ionically conductive material. After the heating step, KOH solution and the selected electrically conductive material is added in a second mixing step. If EMD had not  
5 already been added, then EMD can be included in the second mixing step. If EMD was included in the first mixing step, then additional EMD can optionally be added for open circuit voltage (“OCV”) maintenance as the heating step can affect the air cathode OCV. The material exits the heating step as friable and is easily mixed and granulated in the second step, thus not requiring any regrinding. The second mixing step can produce granulates which  
10 are environmentally stable and ready for molding into the desired air cathode shape.

In an aspect, the cathode can be prepared using a tool 10, which is shown in FIG. 2A, comprising a cylindrically shaped outer tube 15, a center pin 20, and end bushings 25 and 26 that are arranged to create an annular interior space. A desired amount of the cathode material powder 30 is loaded into the tool 10 with inserted center pin 20. The top end bushing 26 is  
15 inserted and the tool is placed under a press.

Referring to FIG. 2B, an external pressure is applied (shown by arrows) to drive end bushings to a pre-defined depth. The resulting hollow cathode ring 35 can then be transferred into a can.

Referring to FIG. 3, a standard ANSI sized cylindrical can 100 is shown, which is  
20 useful to build the air assisted battery.

In this aspect, three cathode rings 121, 122, and 123 are used to build the cell. After all cathode sections are transferred into the can, additional pressure can be applied to press the cathode against the can wall, ensuring intimate contact between the air cathode 120 and the can 100.

A separator assembly 130 is placed into the can 100 after the cathode is in place and positioned adjacent the air cathode 120. The separator assembly is in a fashion typical for alkaline cells. Separator material can be selected from separators traditionally used in the industry, for example non-woven materials. Measured amount of typical electrolyte used in alkaline cells, such as 40% KOH solution, can be added to the separator to wet it and enable  
25 its ionic conductivity. After electrolyte is absorbed, the inner volume is filled with the measured amount of zinc material to form an anode 140. A conductive nail 150, negative  
30

terminal 160 and sealing assembly (not shown) is then placed into the cell and locked in place.

In another aspect, cathode can be made by loading desired amount of cathode material powder directly into the bottom of the can and then driving a center pin through the cathode material to form the cathode. This cathode making method is typical of commercial alkaline battery cathode manufacturing is called impact molding because of the impact force used to shape the cathode. The can is first placed in a reinforcing cylinder before the center pin impact creates the annulus shaped cathode so as to maintain the can integrity.

Anode material can be in the form of slurry, comprising alloyed zinc powder, KOH, gelling agent and stabilizing additives, such as zinc oxide, indium hydroxide, organic surfactants, and others. Anode slurry is prepared and handled in a way typical of commercial alkaline batteries.

Except for the cathode material powder preparation, all materials and processes can be typical for the alkaline industry and familiar to those skilled in the art. Therefore, many of the existing processes and equipment can be utilized in the manufacture of the battery.

The solid ionically conducting polymer material retains the thermoplastic physical properties of its base polymer. For example, it is capable of being thermoformed, extruded or otherwise shaped into a myriad of webs, annulus, powders, meshes, convolutes, coatings, films, and other useful forms. As the cathode materials are encapsulated by the solid ionically conducting polymer material the air cathode is itself thermoplastic as it can be molded while maintaining this encapsulation. This property solid ionically conducting polymer material is particularly useful in a metal-air or air-assisted battery in that the air electrode can now be made of a single layer in a plurality of shapes.

Like most polymers, the solid ionically conducting polymer material can be mixed with materials to alter its physical properties. For metal-air or air-assisted battery, differential ingress of oxygen, water and carbon dioxide is preferred. Hydrophobicity can be engineered into the metal-air or air-assisted battery air electrode by the addition of a hydrophobic material such as a Teflon®, liquid crystal polymers or other known water barriers. Carbon dioxide can be rendered impermeable with the use of an appropriate film, or adsorbed by an appropriate compound such as a zeolite with engineered or naturally occurring adsorption sites. Such a carbon dioxide zeolite can be mixed with the solid ionically conducting polymer

material or located in a film between the cathode and any air access hole to create a gas differentiation system that enables oxygen to enter the cell and reach the air electrode at a rate necessary to enable the desired electrochemical drain rates, while selectively preventing carbon dioxide and water permeability.

5           Air is supplied into the cell depicted in FIG. 3 through air holes (not shown), positioned in the seal assembly, and/or in the can walls. A gas differentiation system can be used to protect the cell from leakage and such a membrane can be located intermediate any air ingress portal such as an air hole and the air electrode to regulate atmospheric gas permeability and to prevent water from leaving the cell. Such a gas differentiation system can  
10 include a hydrophobic protective membrane, such as Teflon film, solid ionically conducting polymer material, other gas differentiating membranes such as Zitex® or the undoped material detailed in Example 1. Zeolites and other adsorption additives can also be included by their incorporation into a film or by being otherwise put into the gas differentiation system.

15           In an aspect, the air cathode can be used in a battery with a mixed cathode structure. This mixed structure uses the air cathode as described in combination with a typical alkaline cathode construction. For example, in the construction described in association with FIG. 3, there are shown three cathode rings 121-123. In this aspect at least one of the rings would not comprise the solid ionically conducting polymer material in order to provide a hybrid cathode  
20 which would include at least one ring having manganese dioxide, conductive carbon, KOH electrolyte, and other additives typical of alkaline battery cathodes, but no solid ionically conducting polymer material. In addition, at least one ring would comprise the solid ionically conducting polymer material and at least an electrically conducting material such as carbon. This ring comprising the solid ionically conducting polymer material could also  
25 further comprise manganese dioxide or another codepolarizer, a catalyst, and other mentioned additives. The construction of this aspect enables high drain rates because of the lower relative impedance of the ring without the solid ionically conducting polymer material.

          However, the construction also enables the ring without the solid ionically conducting polymer material to be recharged because of its ability to conduct hydroxide ions via the  
30 aqueous electrolyte. Thus such a hybrid construction further demonstrates the utility of the

solid ionically conducting polymer material and its ability to improve the performance of typical systems when used in such systems.

Thus the solid ionically conducting polymer can be included in an air electrode which has a desired shape, surface area, porosity, and gas differentiation properties.

5

### Example 3

Ground poly(phenylene sulfide) polymer and lithium hydroxide monohydrate were added together in the proportion of 67% to 33% (by wt.), respectively, and mixed using jet milling. The resulting ion containing compound - polymer mix, manganese dioxide powder  
10 (EMD from Erachem) and C45 carbon black were added together in the proportion of 30%, 50% and 20%, respectively, and thoroughly mixed using a V-blender.

The V-blended mixture was placed into a heating container and heated to a desired heat-treatment temperature (305 to 345°C, or greater than 300°C, and between 250-450°C) for a specified time (10-50 minutes). After cooling the resulting material was mixed with carbon.  
15 In an aspect the composition is 50% manganese dioxide, 20% Ketjenblack EC-600JD and 30% polymer/LiOH mix (by weight). In another aspect the carbon can comprise 10-30 wt% and manganese dioxide 40-70 wt%, with the balance the polymer, ionic compound and other additives.

The cathode resulting powder was re-grinded, mixed with 40% KOH solution at about  
20 6 wt. to create an air cathode mix.

### Example 4

Air cathode mix from Example 3 was loaded into a tool, comprising a cylindrically shaped outer tube, a center pin and end bushings. A desired amount of the cathode material  
25 powder is loaded into the tool with inserted bottom bushing and center pin. Then the top bushing is inserted and the tool is placed under the press. Hydraulic pressure is applied to drive end bushings to a pre-defined depth to form cathode sections shaped as hollow rings (Fig. 2a).

After bushings are extracted, the cathode section can be transferred into the can.  
30 Typically, three cathode sections are used to build a cell. After cathode sections are put in

place, center pin is inserted again and pressure is applied to expand cathode sections locking them in place (Fig 2b).

Traditional separator assembly, made of commercial non-woven separator (NKK), was inserted into the cell. Then 0.6 cc of 40% KOH solution was added. Zn anode slurry, extracted from commercial alkaline cells, was added inside the separator. The nail and sealing assembly was inserted and locked by lightly compressing cell walls (Fig. 2c).

Air access holes were drilled in the cell can to provide air access.

Example 5

The AA cell construction including the air cathode and cell design and described in Example 4 are compared to a comparative commercial AA cell (“Coppertop®”) in the below Table 6:

TABLE 6

	Example 4 (grams)	Coppertop (grams)
Cathode:		
EMD	1.0	8.1
Carbon	0.4	0.63
Binder		0.05
KOH	0.17	0.17
Polymer Electrolyte	0.6	
Anode:		
Zinc Slurry	6.8	3.8

The air cathode energy density is relatively high and therefore it does not need to be as thick as the cathodes of typical alkaline batteries, and the reduced volume lowers the raw material requirements of the air cathode. The larger interior void provided by the thinner cathode allows for a larger anode for the metal air battery. The larger interface area between the anode and cathode also allows for higher mass transfer area between the electrodes which enables higher drain rates. The amount of zinc slurry can be almost doubled relative the commercial cell, and the corresponding zinc to EMD ratio is much greater than 1:1. In other words, the anode to cathode electrochemically active weight ratio is greater than one (1:1). The cathode codepolarizer EMD to Carbon weight ratio – is greater than 2:1, and the codepolarizer EMD to polymer electrolyte weight ratio is greater than 1:1.

## Example 6

After checking open circuit voltage and impedance, assembled cells from Example 4 were placed into the cell holders and tested using a Maccor 4600A instrument.

5 FIG. 4 shows a discharge curve of the AA cell created in Example 4 and comparative Duracell Coppertop® (black) under continuous 150 mA discharge. The cell delivered 4.2Ah to a 0.8V voltage cut off. In comparison, commercial cell capacity under the same conditions was limited to about 2.6 Ah.

## 10 Example 7

After checking open circuit voltage and impedance, cells assembled in Example 4 were placed into the cell holders and tested using a Maccor 4600A instrument.

Each cell was subjected to intermittent discharge at 24 Ohm resistance load for 15 seconds, followed by 45-second rest. The test was continued until cell voltage dropped to 15 1.0V. This discharge protocol can be considered as an accelerated version of a standard remote control test, since standard test applies load only 8 hours per day.

Referring to FIG. 5, the cell from example 4 was compared against both a commercially sold Duracell Coppertop® and Energizer Max® cells. Under these discharge conditions, the cell of Example 4 outlasted commercial AA cells by more than 20%.

20

## Example 8

After checking open circuit voltage and impedance, cells from Example 4 were placed into the cell holders and tested using Maccor 4600A instrument.

25 Cells were subjected to intermittent discharge at 3.9 Ohm resistance load for 1 hour, followed by 1-hour rest. Test was continued until cell voltage drops to 0.8V. The discharge protocol can be considered as an accelerated toy test as it is utilizing shorter rest period compared to standard toy test (1 hour vs. 23 hours).

FIG. 6 shows the discharge as a function of time. Under these discharge conditions the cell of Example 4 outlasted commercial cells by almost 200%.

30 In addition the AA cell demonstrated greater than 3Ah capacity during: Continuous constant current discharge at current between 150 and 300 mA with 0.8 V voltage cutoff;

Intermittent discharge at current between 150 and 300 mA cutoff applied for 1 hour, followed by 1-hour rest period (0.8V voltage cutoff); Continuous constant current discharge at 50 mA to 1.0V voltage cutoff; Intermittent discharge at 50 mA with applied for 1 hour, followed by 1-hour rest period (1.0V voltage cutoff); Continuous constant resistance discharge at 3.9 Ohm to 0.8 voltage cutoff; Intermittent constant resistance discharge when 3.9 Ohm resistance is applied for 1 hour, followed by 1-hour rest period (0.8 voltage cutoff); Continuous constant resistance discharge of at 42 Ohm to 1.0V voltage cutoff; and Intermittent constant resistance discharge when 42 Ohm resistance is applied for 15 seconds, followed by 45-second rest period (1.0V voltage cutoff).

10

#### Example 9

To compare performance of cells made according to this application relative competing technologies, which typically are implemented in different form-factors, cell capacity and discharge rate were normalized per cell volume. Cells which were assembled in Example 4 and Duracell Coppertop alkaline cells were both discharged at constant current of 150 and 250 mA. Capacity delivered during discharge was divided by the volume of a standard AA cell to produce Ah/L. Discharge current was similarly normalized by cell volume to yield A/L.

15

Panasonic PR2330 coin cells were discharged at 10 and 15 mA constant current.

20

Capacity and discharge rate were normalized per cell volume as described above.

Performance parameters of Cegasa ALR40/100 cell, smallest cell of cylindrical design, were taken from datasheet and normalized to cell volume. Performance of air assisted Eveready D cell was calculated based on results disclosed in US Patent 5,079,106. Performance of air assisted Duracell AA cell was calculated based on results reported in US Patent 7,238,448 and US Patent 7,615,508. Discharge rate on intermittent discharge was converted to continuous discharge equivalent by averaging current draw over the reported duty cycle. For example, 600 mA load for 2 seconds, followed by 28-second rest, is equivalent to 40 mA continuous discharge ( $600 * 2 / 30 = 40$ ). Data was normalized per cell volume as described above.

25

Referring to FIG. 8 there is shown a comparison of volumetric capacity vs rate profiles for the above listed cells. The air assisted cells perform at discharge rates typical for alkaline cells, and demonstrate significantly greater cell capacity.

It is theorized that the solid ionically conducting polymer material improves the performance by participating in the electrochemical reaction (oxygen reduction), by  
5 facilitating oxygen reduction, and by improving hydrophobic properties of the cathode.

#### Thin Film Air Cathode

In an aspect of the invention, the described air cathode including the solid ionically  
10 conducting polymer material can take the form of a thin film structure. The solid ionically conducting polymer material enables the air cathode to comprise more than one film layer which can be incorporated into a structure such as a can, or operate as a flexible thin film battery operating with a flexible housing or without any container or housing. Referring to FIG. 7, there is shown a graphical representation of the thin film battery 200 of this aspect.  
15 Although this aspect is characterized as a thin film battery, it is not to be limited to the relative thickness of the battery components that will be described.

A cathode 210 is shown as comprising three component layers, an air electrode 220, having both a first surface 221 and second surface 222 which receives oxygen from the atmosphere or another oxygen source. The air cathode is electrically connected to a cathode  
20 collector 225 which contacts the air cathode to provide electrical conductivity from the air cathode 220 to a load 226. The air cathode comprises material and an electrically conductive material such as carbon, graphite or other materials typically used in cathodes as electrically conducting materials.

The air cathode can receive oxygen through its second surface 222 from a gas  
25 differentiation layer 230. The gas differentiation layer is optional and can be incorporated into the air cathode in an aspect of the invention. The gas differentiation layer can be useful and required in environments where the air electrode would benefit: from receiving larger partial concentrations of oxygen than are available the battery, such as from air; when the battery would benefit from lower concentrations of water and carbon dioxide than are  
30 otherwise available the battery; and when the battery would benefit from a barrier to water loss flowing from the air electrode. Differential transport of oxygen, water and carbon

dioxide can be engineered into the gas differentiation layer by the inclusion of materials that enable such differential transport and which can be included into the gas differentiation layer. Such materials include: hydrophobic materials such as a Teflon, liquid crystal polymer (“LCP”) or other known water barriers, carbon dioxide adsorption zeolites with engineered or naturally occurring adsorption sites. Such materials can be mixed with the solid ionically conducting polymer material or other membrane to create a gas differentiation system that enables oxygen to enter the cell and reach the air electrode at a rate necessary to enable the desired electrochemical drain rates, while selectively retarding and preventing carbon dioxide and water permeability.

Under load, and with oxygen being transported to the air electrode 220, the air electrode acts to electrochemically reduce the oxygen to hydroxide ions, which are ionically conducted along with oxygen from the air electrode via its component solid ionically conducting polymer material to the first surface 221. The first surface can ionically communicate with an optional codepolarizer containing air cathode second portion 240. The air cathode second portion comprises the solid ionically conducting polymer material, an electrically conductive material such as carbon, and a codepolarizer such as EMD or other suitable cathode depolarizer. In an aspect, the cathode second portion can include potassium hydroxide solution and act to transport it to the first surface 221 and throughout the cathode 210 in an aqueous metal-air cell. The EMD or other codepolarizer electrochemically reacts and in its reduced form, can be reoxidized by the peroxide ions and oxygen transported to the cathode second portion or combination air cathode. Although this layer or second portion is described as a separate film, in an aspect, it can also be incorporated into the air cathode or substituted therefore. This layer is also ionically conductive as it comprises the solid ionically conducting polymer material, and is electrically conductive because of the carbon or other suitable electrical conductive material, and acts to ionically conduct hydroxide ions to the anode across a separator layer 250.

The separator layer 250 is comprised of the solid ionically conducting polymer material and is not electrically conductive as it acts as a dielectric barrier between the cathode 210 and an anode 260. This separator layer can be a distinct layer or incorporated into the anode 260. Thus, separator layer 250 is ionically conducting, dielectric and non-electrochemically active and interposed between the air electrode 250 of the cathode 210 or

the second portion 240 when it is included. In an aqueous battery, the separator layer also acts as a fluid transport layer between the anode and cathode. The separator layer is interposed between the anode and cathode and adjacent the cathode whether it comprises the air cathode and/or the second cathode layer.

5           The anode 260 includes an anode current collector 265 and is either physically connected to it, such as if the anode is a metal foil or structure, or electrically connected to it if the anode comprises an electrochemically active material disposed in a material such as a gel. In an aspect the anode 260 can include solid ionically conducting polymer material, and if it does so, the separator layer 250 is not required in that the solid ionically conducting  
10           polymer material can act to electrically insulate the electrochemically active material and any electrically conductive material from the cathode 210. If the electrochemically active material is enclosed by the solid ionically conducting polymer material, then the anode may not require any additional environmental protection. However, such protection can be provided by including the anode and the battery in a pouch, can, housing or other typical battery  
15           enclosure.

          This described aspect of the invention provides flexibility in design and enables a high energy density flexible battery. The battery 200 and its components can be scaled for the application and enclosed or unenclosed. As the solid ionically conducting polymer material is a thermoplastic, the described components of the battery 200 can be heat sealed, coextruded  
20           or otherwise integrated into a single coherent film.

          While the invention has been described in detail herein in accordance with certain preferred embodiments thereof, many modifications and changes therein may be affected by those skilled in the art without departing from the spirit of the invention. Accordingly, it is our intent to be limited only by the scope of the appending claims and not by way of the  
25           details and instrumentalities describing the embodiments shown herein. It is to be understood that variations and modifications can be made on the aforementioned structure without departing from the concepts of the describe aspects, and further it is to be understood that such concepts are intended to be covered by the following claims unless these claims by their  
30           language expressly state otherwise.

## CLAIMS

What is claimed is:

1. A metal-air battery comprising: an air electrode that includes: an electrically  
5 conductive material, and a solid ionically conducting polymer material; a negative electrode  
comprising a first electrochemically active metal; and an ionically conducting, dielectric non-  
electrochemically active material interposed between the air electrode and the negative  
electrode and in contact with the air electrode, wherein the air electrode acts to reduce oxygen  
when the air electrode is exposed to an oxygen gas source and when the battery is under  
10 load.
2. The battery of claim 1, wherein the solid ionically conducting polymer material  
comprises:  
a crystallinity greater than 30%; a melting temperature;  
15 a glassy state;  
and both at least one cationic and anionic diffusing ion, wherein at least one diffusing  
ion is mobile in the glassy state.
3. The battery of claim 2, wherein the solid ionically conducting polymer material  
20 further comprises a plurality of charge transfer complexes.
4. The battery of claim 3, wherein the solid ionically conducting polymer material  
comprises a plurality of monomers, and wherein each charge transfer complex is positioned  
on a monomer.  
25
5. The battery of claims 1 or 4, wherein the electronic conductivity of the solid ionically  
conducting polymer material is less than  $1 \times 10^{-8}$  S/cm at room temperature.
6. The battery of claim 1, wherein the solid ionically conducting polymer material  
30 comprises:  
a plurality of monomers;

a plurality of charge transfer complexes, wherein each charge transfer complex is positioned on a monomer;

wherein the electronic conductivity of the solid ionically conducting polymer material is less than  $1 \times 10^{-8}$  S/cm at room temperature.

5

7. The battery of claim 6, wherein the crystallinity of the solid ionically conducting polymer material is greater than 30%.

8. The battery of claim 6, wherein the solid ionically conducting polymer material has a glassy state which exists at temperatures below the melting temperature of the solid ionically conducting polymer material.

10

9. The battery of claim 6, wherein the solid ionically conducting polymer material further comprises both a cationic and anionic diffusing ion, whereby at least one diffusing ion is mobile in a glassy state of the solid ionically conducting polymer material, and wherein the crystallinity of the solid ionically conducting polymer material is greater than 30%.

15

10. The battery of claims 3 or 6, wherein the charge transfer complex is formed by the reaction of a polymer and an electron acceptor.

20

11. The battery of claim 6, wherein the solid ionically conducting polymer material has a glassy state, and at least one cationic and at least one anionic diffusing ion, wherein each diffusing ion is mobile in the glassy state.

12. The battery of claim 1, wherein the melting temperature of the solid ionically conducting polymer material is greater than 250°C.

25

13. The battery of claim 1, wherein the ionic conductivity of the solid ionically conducting polymer material is greater than  $1.0 \times 10^{-5}$  S/cm at room temperature.

30

14. The battery of claim 1, wherein the solid ionically conducting polymer material comprises a single cationic diffusing ion, wherein the diffusivity of the cationic diffusing ion is greater than  $1.0 \times 10^{-12} \text{ m}^2/\text{s}$  at room temperature.
- 5 15. The battery of claim 1, wherein the solid ionically conducting polymer material comprises a single anionic diffusing ion, wherein the diffusivity of the anionic diffusing ion is greater than  $1.0 \times 10^{-12} \text{ m}^2/\text{s}$  at room temperature.
- 10 16. The battery of claim 2, wherein at least one cationic diffusing ion comprises an alkali metal, an alkaline earth metal, a transition metal, or a post transition metal.
17. The battery of claim 2, wherein the solid ionically conducting polymer material comprises a plurality of monomers and wherein there is at least one anionic diffusing ion per monomer.
- 15 18. The battery of claim 2, wherein the solid ionically conducting polymer material comprises a plurality of monomers and wherein there is at least one cationic diffusing ion per monomer.
- 20 19. The battery of claim 2, wherein there is at least one mole of the cationic diffusing ion per liter of solid ionically conducting polymer material.
- 25 20. The battery of claim 6, wherein the charge transfer complex is formed by the reaction of a polymer, electron acceptor, and an ionic compound, wherein each cationic and anionic diffusing ion is a reaction product of the ionic compound.
21. The battery of claim 2, wherein the solid ionically conducting polymer material is formed from at least one ionic compound, wherein the ionic compound comprises each at least one cationic and anionic diffusing ion.
- 30 22. The battery of claim 1, wherein the solid ionically conducting polymer material is a thermoplastic.

23. The battery of claims 2, wherein each at least one cationic and anionic diffusing ion have a diffusivity, wherein the cationic diffusivity is greater than the anionic diffusivity.
- 5 24. The battery of claim 1, wherein the cationic transference number of the solid ionically conducting polymer material is greater than 0.5 and less than 1.0.
25. The battery of claim 1, wherein the solid ionically conducting polymer material comprises lithium, and wherein the concentration of lithium is greater than 3 moles of lithium  
10 per liter of solid ionically conducting polymer material.
26. The battery of claim 2, wherein the cationic diffusing ion comprise lithium.
27. The battery of claim 2, wherein the diffusing cation is monovalent.  
15
28. The battery of claim 2, wherein the valence of the diffusing cation is greater than one.
29. The battery of claim 1, wherein the air cathode produces hydroxide ion when it reduces oxygen, and wherein the solid ionically conducting polymer material ionically  
20 conducts hydroxide ion.
30. The battery of claim 2, wherein the diffusing anion is a hydroxide ion.
31. The battery of claim 2, wherein diffusing anion is monovalent.  
25
32. The battery of claim 2, wherein both the diffusing anion and the diffusing cation are monovalent.
33. The battery of claim 2, wherein each at least one cationic and anionic diffusing ion  
30 have a diffusivity, wherein the anionic diffusivity is greater than the cationic diffusivity.

34. The battery of claim 2, wherein the cationic transference number of the solid ionically conducting polymer material is equal to or less than 0.5, and greater than zero.
35. The battery of claim 2, wherein one of the at least cationic diffusing ion, has a  
5 diffusivity greater than  $1.0 \times 10^{-12} \text{ m}^2/\text{s}$ .
36. The battery of claim 2, wherein one of the at least one anionic diffusing ion has a diffusivity greater than  $1.0 \times 10^{-12} \text{ m}^2/\text{s}$ .
- 10 37. The battery of claim 2, wherein one of both the at least one anionic diffusing ion and at least one cationic diffusing ion has a diffusivity greater than  $1.0 \times 10^{-12} \text{ m}^2/\text{s}$ .
38. The battery of claim 1, wherein the solid ionically conducting polymer material comprises a plurality of monomers, wherein each monomer comprises an aromatic or  
15 heterocyclic ring structure positioned in the backbone of the monomer.
39. The battery of claim 38, wherein the solid ionically conducting polymer material further includes a heteroatom incorporated in the ring structure or positioned on the backbone adjacent the ring structure.
- 20 40. The battery of claim 39, wherein the heteroatom is selected from the group consisting of sulfur, oxygen or nitrogen.
41. The battery of claim 40, wherein the heteroatom is positioned on the backbone of the  
25 monomer adjacent the ring structure.
42. The battery of claim 41, wherein the heteroatom is sulfur.
43. The battery of claim 1, wherein the solid ionically conducting polymer material is pi-  
30 conjugated.

44. The battery of claim 1, wherein the solid ionically conducting polymer material comprises a plurality of monomers, wherein the molecular weight of each monomer is greater than 100 grams/mole.
- 5 45. The battery of claim 1, wherein the solid ionically conducting polymer material is hydrophilic.
46. The battery of claim 13, wherein the ionic conductivity of the solid ionically conducting polymer material is isotropic.
- 10 47. The battery of claim 1, wherein the solid ionically conducting polymer material has an ionic conductivity greater than  $1 \times 10^{-4}$  S/cm at room temperature.
48. The battery of claim 1, wherein the solid ionically conducting polymer material has an ionic conductivity greater than  $1 \times 10^{-3}$  S/cm at  $80^{\circ}\text{C}$ .
- 15 49. The battery of claim 1, wherein the solid ionically conducting polymer material has an ionic conductivity greater than  $1 \times 10^{-5}$  S/cm at  $-40^{\circ}\text{C}$ .
- 20 50. The battery of claim 30, where the cationic diffusing ion comprises lithium, and wherein the diffusivity of lithium ion and the hydroxide ion are both greater than  $1.0 \times 10^{-13}$   $\text{m}^2/\text{s}$  at room temperature.
51. The battery of claim 1, wherein the solid ionically conducting polymer material is non-flammable.
- 25 52. The battery of claim 1, wherein the Young's modulus of the solid ionically conducting polymer material is equal to or greater than 3.0 MPa.
- 30 53. The battery of claim 1, wherein the solid ionically conducting polymer material becomes ionically conductive after being doped by an electron acceptor in the presence of an ionic compound that either contains both a cationic and anionic diffusing ion or is convertible into both the cationic and anionic diffusing ion via reaction with the electron acceptor.

54. The battery of claim 1, wherein the solid ionically conducting polymer material is formed from the reaction product of a base polymer, electron acceptor and an ionic compound.
- 5
55. The battery of claim 54, wherein the base polymer is a conjugated polymer.
56. The battery of claim 54, wherein the base polymer is PPS or a liquid crystal polymer.
- 10 57. The battery of claim 1, wherein the air electrode further comprises a second electrochemically active material.
58. The battery of claim 57, wherein the second electrochemically active material comprises a metal oxide.
- 15
59. The battery of claim 58, wherein the metal oxide is manganese dioxide.
60. The battery of claim 58, wherein the first electrochemically active material comprises zinc.
- 20
61. The battery of claim 1, wherein the first electrochemically active material comprises zinc, aluminum, calcium, magnesium, potassium, sodium or lithium.
62. The battery of claim 57, wherein the second electrochemically active material is intermixed with the electrically conductive material and the solid ionically conducting polymer material.
- 25
63. The battery of claim 1, wherein the ionically conducting, dielectric non-electrochemically active material comprises both a nonwoven separator disposed adjacent the air electrode and an aqueous electrolyte.
- 30

64. The battery of claim 1, wherein the electrically conductive material comprises carbon.

65. The battery of claim 58, wherein the battery is non-aqueous and the ionically  
5 conducting, dielectric non-electrochemically active material comprises solid ionically  
conducting polymer material.

66. The battery of claim 62, wherein the electrically conductive material comprises  
carbon.

10

67. The battery of claim 66, wherein the ionically conducting, dielectric non-  
electrochemically active material comprises both a nonwoven separator disposed adjacent the  
air electrode and an aqueous electrolyte.

15 68. The battery of claim 1, wherein the ionically conducting, dielectric non-  
electrochemically active material comprises the solid ionically conducting polymer material.

69. The battery of claim 1, wherein the electrically conductive material is mixed with the  
solid ionically conducting polymer material and wherein the air electrode is thermoplastic.

20

70. The battery of claim 1, wherein the said oxygen gas source is an air source, wherein  
the air source includes a first concentration of oxygen, carbon dioxide and water vapor gas,  
wherein the battery further comprises an air differentiation system fluidly interposed between  
the air electrode and the air source, and wherein the air differentiation system supplies the air  
25 electrode with a second concentration of oxygen, carbon dioxide and water vapor gas, and  
wherein the air differentiation system affects the concentration of oxygen reaching the air  
electrode when battery is under load, such that the second concentration of oxygen is greater  
than the first concentration of oxygen.

71. The battery of claim 70, wherein the air differentiation system affects the concentration of carbon dioxide, wherein the second concentration of carbon dioxide is less than the first concentration of carbon dioxide.
- 5 72. The battery of claim 70, wherein the air differentiation system affects the concentration of water, wherein the second concentration of water is less than the first concentration of water.
73. The battery of claim 70, wherein the air differentiation system comprises the solid  
10 ionically conducting polymer material.
74. The battery of claim 70, wherein the air source is atmospheric air and wherein the battery is disposed within an enclosure having an air supply port, wherein the air supply port allows atmospheric air to flow to the air electrode.
- 15 75. The battery of claim 1, wherein the electrically conducting material comprises 10-30 percent by weight of the air electrode.
76. The battery of claim 1, wherein the solid ionically conducting polymer material  
20 comprises 5-50 percent by weight of the air electrode.
77. The battery of claim 57, wherein the second electrochemically active material comprises 10-70 percent by weight of the air electrode.
- 25 78. The air cathode of claim 1, wherein the air cathode further comprises an oxygen reduction catalyst.
79. The air cathode of claim 78, wherein the catalyst is selected from a group comprising carbon, potassium permanganate, manganese dioxide, cobalt tetrapyrazinoporphyrazine  
30 derivatives, perovskites, titanium doped manganese dioxide, cobalt oxide, graphene, Ketjen

Black, doped Ketjen black, carbon nanotubes, carbon fiber, cobalt manganese oxides, electrically conductive polymers, intrinsically conductive polymers, and combinations thereof.

5 80. The battery of claim 1 wherein the air electrode further comprises manganese dioxide, and the manganese dioxide is selected from a group comprising  $\beta$ -MnO<sub>2</sub> (pyrolusite), ramsdellite,  $\gamma$ -MnO<sub>2</sub>,  $\epsilon$ -MnO<sub>2</sub>,  $\lambda$ -MnO<sub>2</sub>, EMD, CMD, and combinations thereof.

10 81. The battery of claim 80, wherein the electrically conductive material comprises carbon, wherein the ratio of weight of manganese dioxide to weight of carbon is greater than 1:1.

15 82. The battery of claim 80, wherein the first electrochemically active material comprises zinc, and wherein the ratio of weight of zinc to weight of manganese dioxide is greater than 1:1.

83. The battery of claim 80, wherein the ratio of weight of manganese dioxide to weight of solid ionically conducting polymer material in the air electrode is greater than 1:1.

20 84. The battery of claim 1, wherein the metal-air battery further comprises a metal can which acts as the positive current collector, wherein the air electrode is in electrical communication with the can.

25 85. The battery of claim 84, wherein the can is cylindrical, and wherein said air cathode is annularly shaped.

86. The battery of claim 85, wherein the can is AA (LR6) sized.

30 87. The battery of claim 85 wherein the battery has greater than 3Ah capacity when tested on continuous constant current discharge at current between 150 and 300 mA with 0.8 V voltage cutoff.

88. The battery of claim 85. wherein the battery has greater than 3Ah capacity when tested on intermittent discharge at current between 150 and 300 mA with cutoff applied for 1 hour followed by 1-hour rest period to a 0.8V voltage cutoff.
- 5 89. The battery of claim 85. wherein the battery has greater than 3Ah capacity when tested on continuous constant current discharge at 50 mA to a 1.0V voltage cutoff.
90. The battery of claim 85. wherein the battery has greater than 3Ah capacity when tested on intermittent discharge at 50 mA which is applied for 1 hour, followed by 1-hour rest  
10 period to a 1.0V voltage cutoff.
91. The battery of claim 85. wherein the battery has greater than 3Ah capacity when tested on continuous constant resistance discharge at 3.9 Ohm to a 0.8V voltage cutoff.
- 15 92. The battery of claim 85. wherein the battery has greater than 3Ah capacity when tested on intermittent constant resistance discharge when 3.9 Ohm resistance is applied for 1 hour, followed by 1-hour rest period to a 0.8V voltage cutoff.
93. The battery of claim 85. wherein the battery has greater than 3Ah capacity when  
20 tested on continuous constant resistance discharge of at 42 Ohm to a 1.0V voltage cutoff.
94. The battery of claim 85. wherein the battery has greater than 3Ah capacity when tested on intermittent constant resistance discharge when 42 Ohm resistance is applied for 15 seconds, followed by 45-second rest period to a 1.0V voltage cutoff.
- 25 95. The battery of claim 1, wherein the oxygen gas permeability of the solid ionically conducting polymer material is greater than its water permeability.
96. A method of manufacturing an air electrode comprising the steps of:  
30 mixing a polymer with an ionic compound and an electron acceptor to create a first mixture;  
heating the first mixture to form the first mixture into a solid ionically conducting polymer material;

mixing the solid ionically conducting polymer material with an electrically conductive material to make a second mixture which is reactive to reduce oxygen and ionically conduct hydroxide ions.

5 97. The method of claim 96, wherein in the second mixture mixing step a codepolarizer is added to the second mixture.

98. The method of claim 97, wherein the codepolarizer is manganese dioxide.

10 99. The method of claim 96, wherein in the first mixing step a codepolarizer is added to the first mixture.

100. The method of claim 99, wherein the codepolarizer comprises manganese dioxide.

15 101. The method of claim 96, wherein the electrically conductive material comprises carbon.

102. The method of claims 96 or 98, further comprising a forming step wherein the second mixture is formed into the air cathode.

20

103. The method of claim 102, wherein in the forming step heat is applied to the second mixture to thermoform the second mixture into an air cathode.

104. The method of claim 102, wherein the air cathode is formed into a film.

25

105. The method of claim 102, wherein the air cathode is formed into an annulus.

106. The method of claim 96, wherein the base polymer is PPS, PEEK, LCP, PPy, or a combination thereof.

107. The method of claim 96, wherein the dopant is selected from DDQ, TCNE, chloranil, SO<sub>3</sub>, ozone, a transition metal oxide, MnO<sub>2</sub>, oxygen and air.

5 108. The method of claim 96, wherein the ionic compound is a salt, hydroxide, oxide or other material containing hydroxide ions or convertible to hydroxide.

109. The method of claim 96, wherein the ionic compound comprises LiOH, NaOH, KOH, Li<sub>2</sub>O, or LiNO<sub>3</sub>.

10

110. The method of claim 96, wherein in the heating step the first mixture is heated to a temperature between 250 and 450 deg. C.

111. The method of claim 96, wherein in the heating step, pressure is applied to the first  
15 mixture while it is being heated.

112. The method of claim 111, wherein the pressure is between 300 and 500 psi.

113. The method of claim 97 wherein in the mixing the second mixture step the manganese  
20 dioxide is encapsulated by the solid ionically conducting polymer material.

114. The method of claim 102, wherein in the forming step the air electrode is extruded.

115. The method of claim 96, wherein in the second mixture mixing step a catalyst is  
25 added to the mixture.

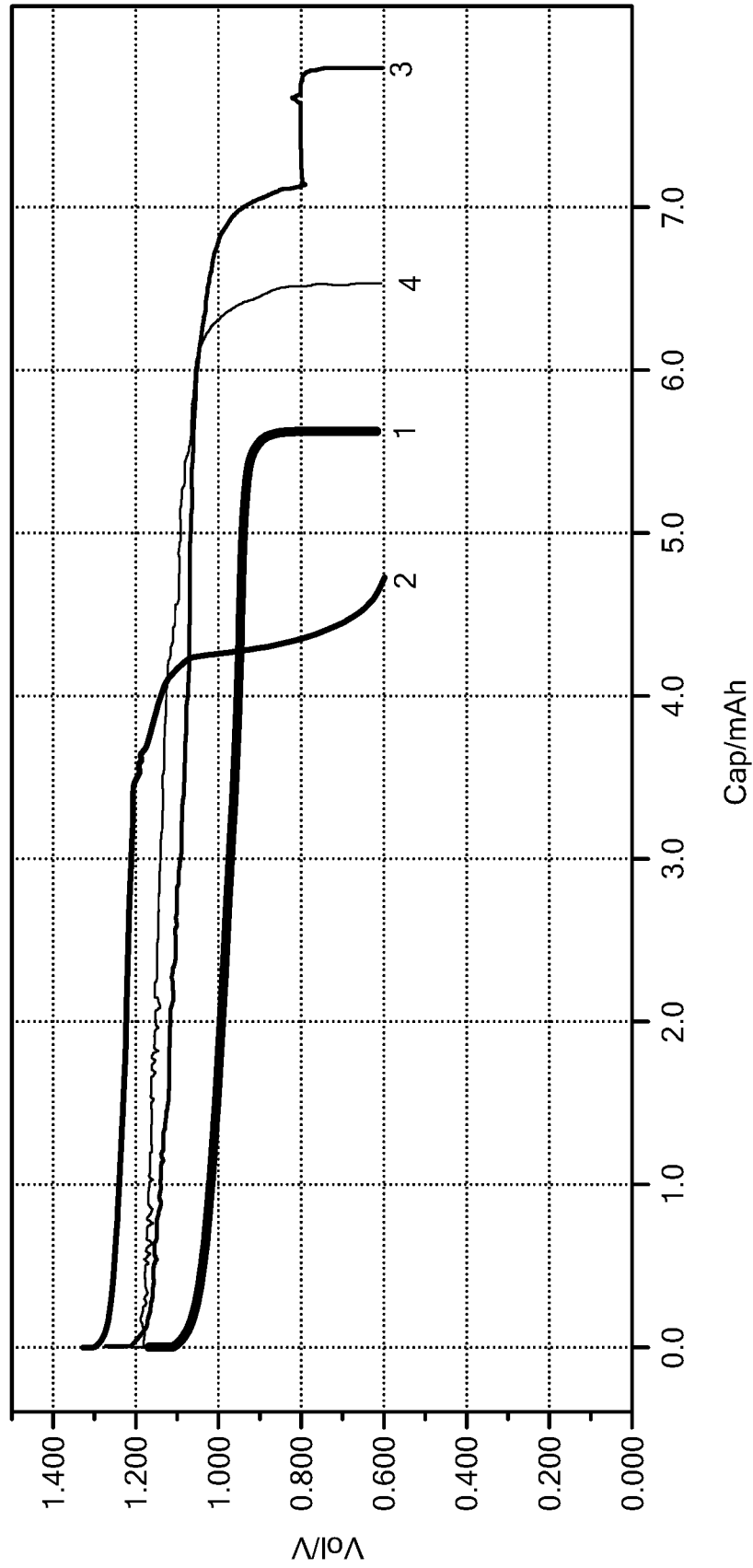
116. The method of claim 96, wherein in the second mixture mixing step a hydrophobic compound is added to the mixture.

117. The method of claim 96, wherein in the second mixture mixing step a carbon dioxide adsorbing compound is added to the mixture.

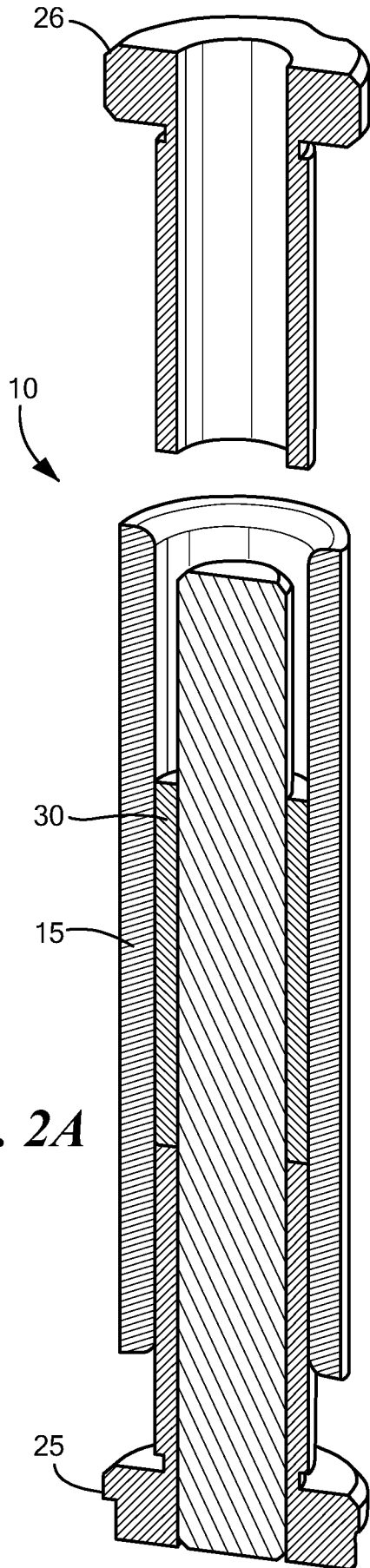
118. The method of claim 105, further comprising a locating step wherein the annulus is  
5 located within a can adjacent an inner surface of the can.

119. The method of claim 118, wherein in the locating step a second annulus shaped cathode portion is located adjacent to both the inner surface of the can and the air cathode.

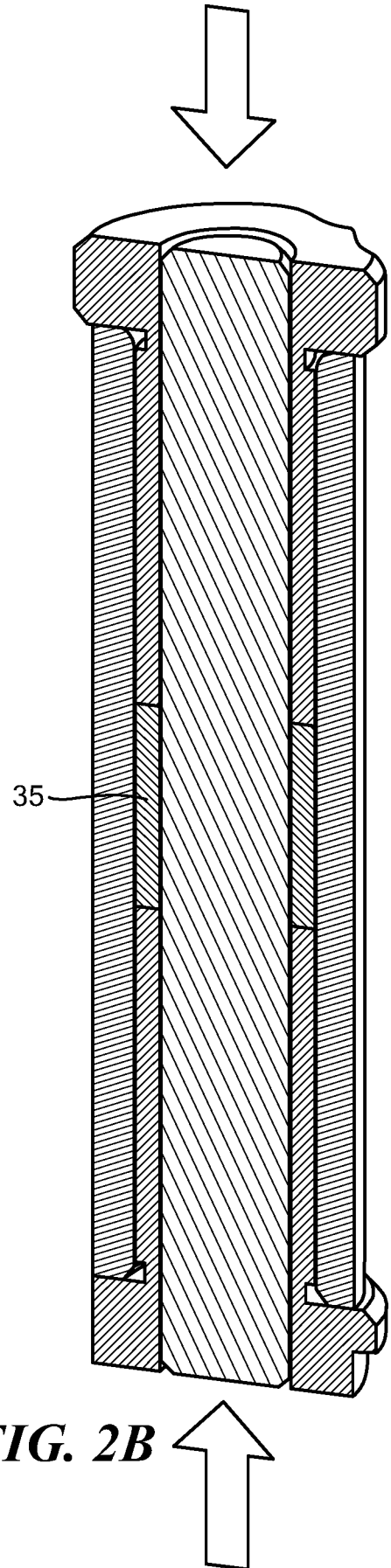
10 120. The method of claim 119, wherein the second cathode portion is free of the solid ionically conducting polymer material.



**FIG. 1**

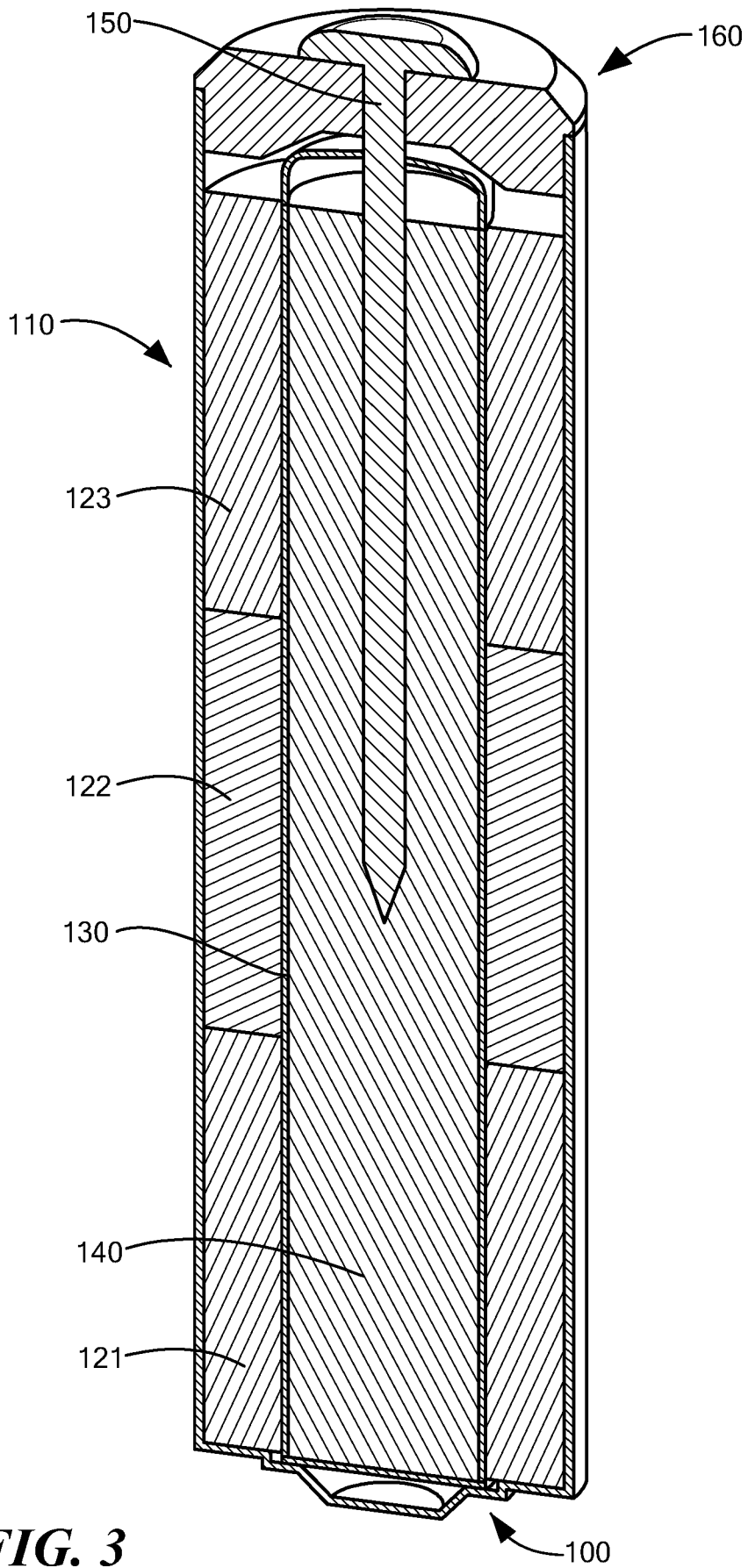


**FIG. 2A**

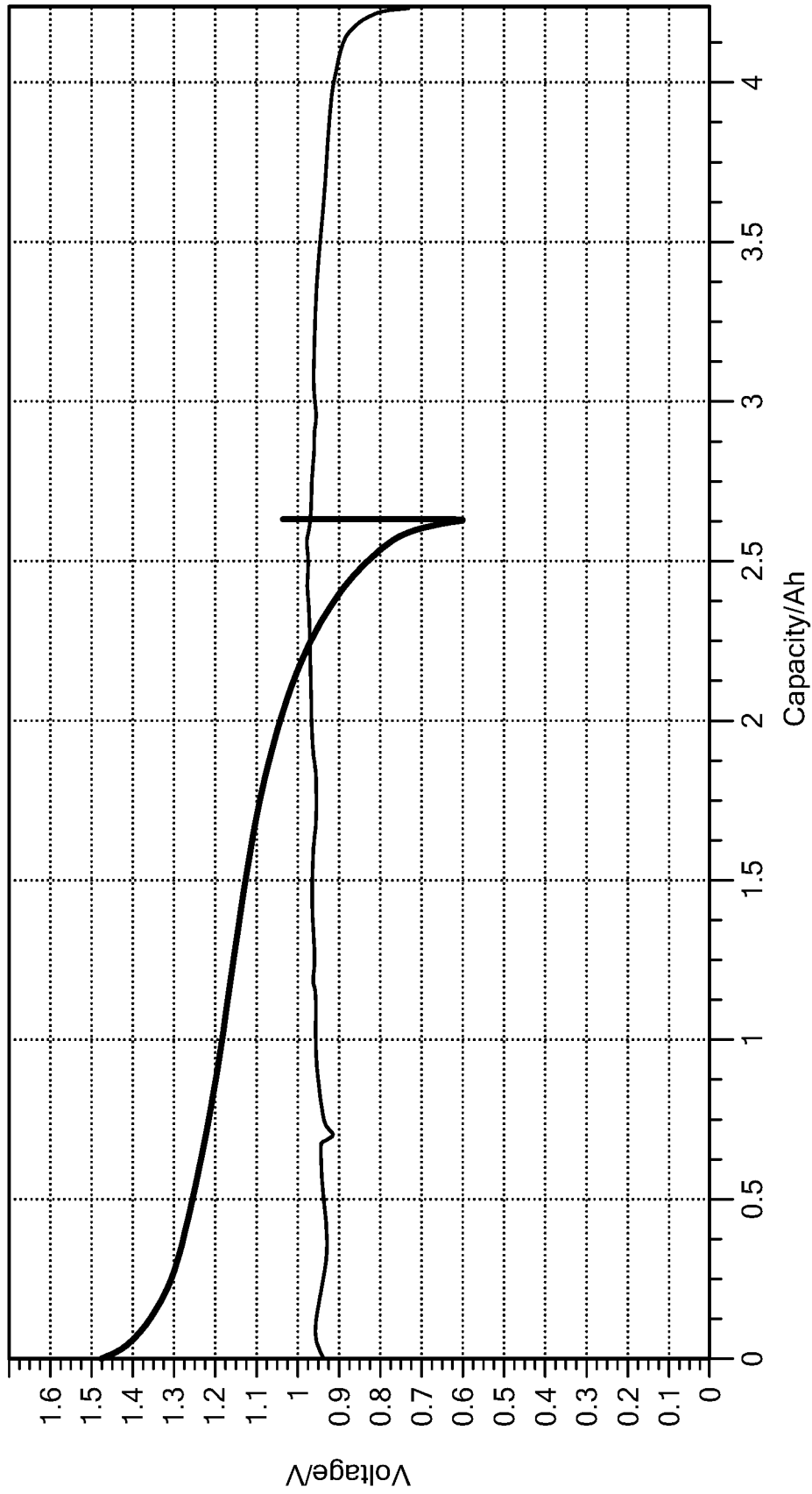


**FIG. 2B**

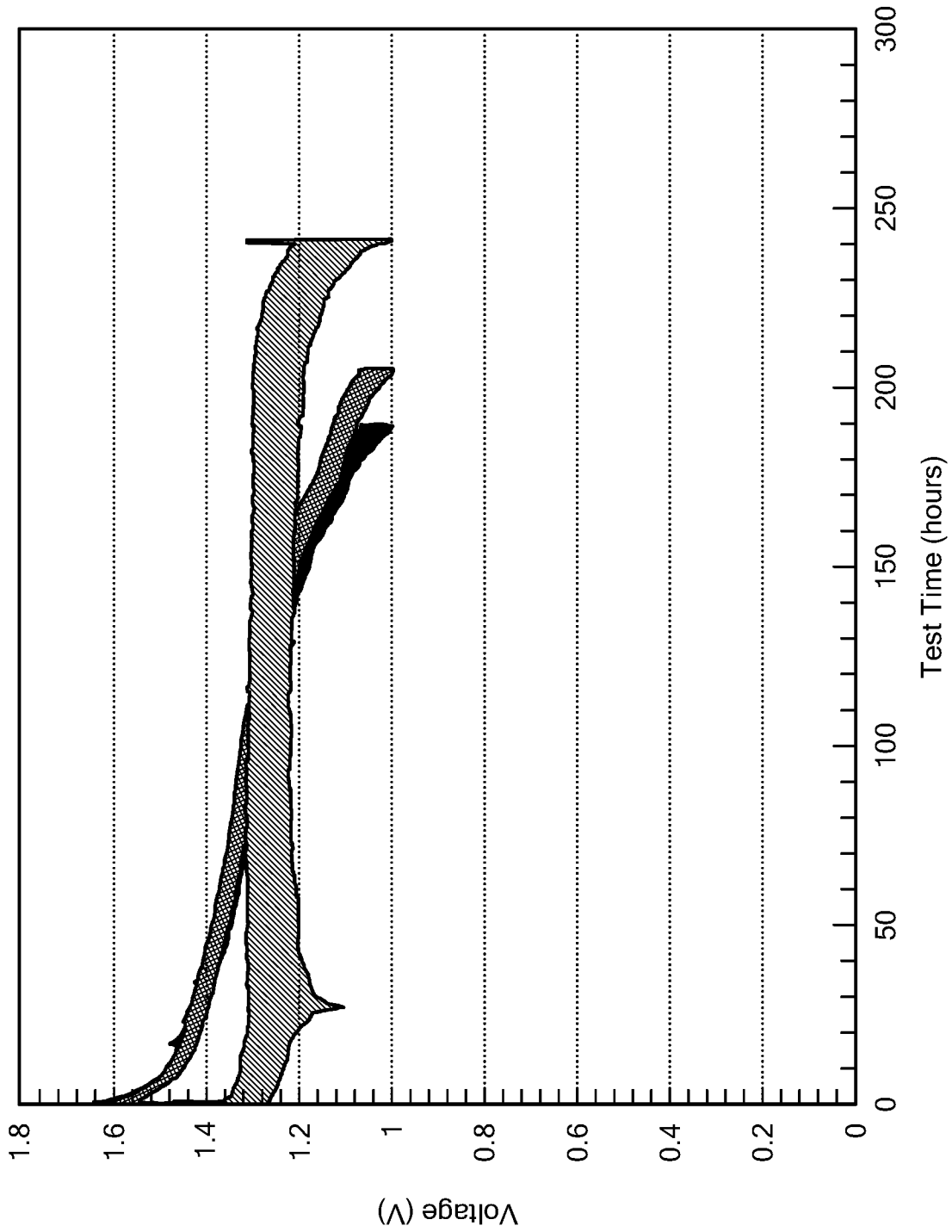
3/7



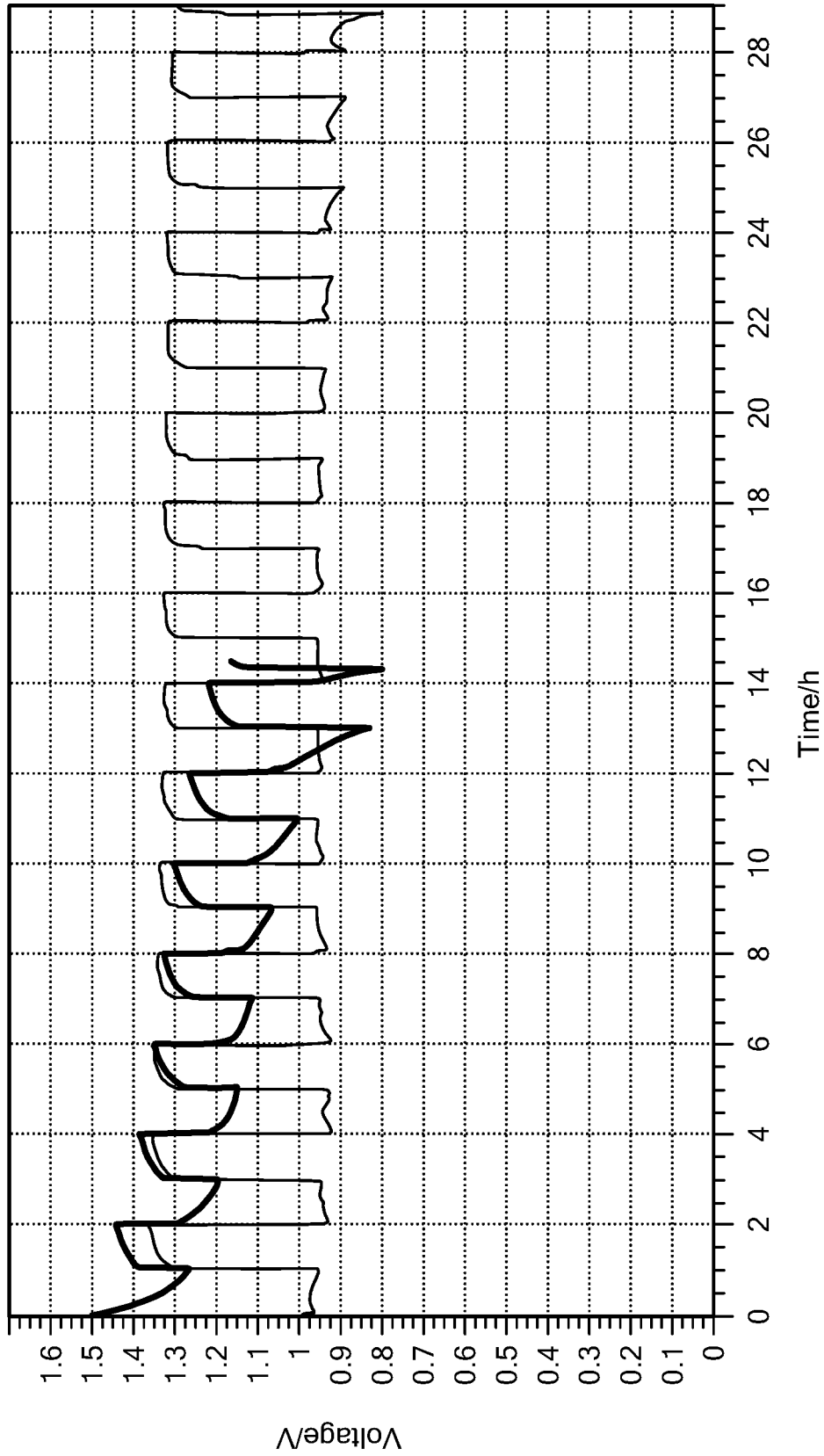
**FIG. 3**



**FIG. 4**



**FIG. 5**



**FIG. 6**

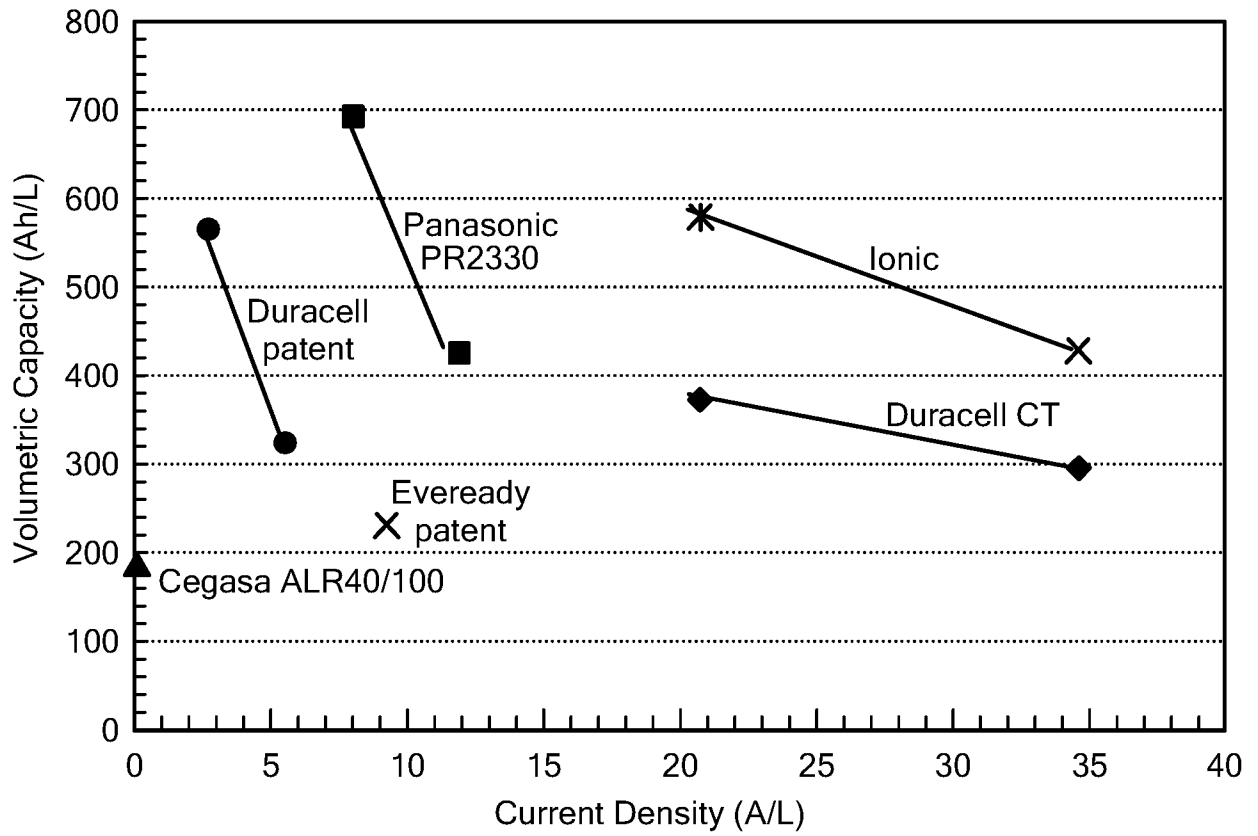


FIG. 7

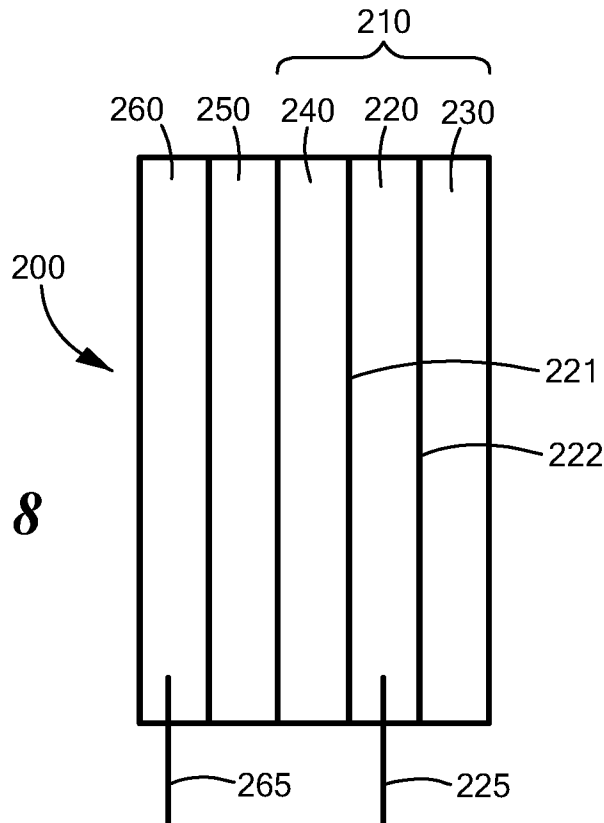


FIG. 8

## INTERNATIONAL SEARCH REPORT

International application No.

PCT/US2016/035040

<b>A. CLASSIFICATION OF SUBJECT MATTER</b> <b>IPC(8) - H01M 4/94; H01M 4/86; H01M 8/10; H01M 8/1025; H01M 8/1044 (2016.01)</b> <b>CPC - H01M 4/94; H01M 4/881; H01M 8/1016; H01M 8/1018; H01M 8/102; H01M 8/1032 (2016.08)</b> According to International Patent Classification (IPC) or to both national classification and IPC		
<b>B. FIELDS SEARCHED</b> Minimum documentation searched (classification system followed by classification symbols) IPC - H01M 2/02; H01M 2/14; H01M 2/16; H01M 4/86; H01M 4/90; H01M 4/94; H01M 8/10; H01M 8/1025; H01M 8/1044 CPC - H01M 2/00; H01M 2/022; H01M 2/14; H01M 2/1673; H01M 4/881; H01M 4/94; H01M 8/1016; H01M 8/1018; H01M 8/102; H01M 8/1032; H01M 8/1041; H01M 8/1044; H01M 8/1051 Documentation searched other than minimum documentation to the extent that such documents are included in the fields searched USPC - 320/127; 320/128; 320/134; 320/135; 320/136; 429/129; 429/164; 429/166; 429/212; 429/245; 429/247; 429/300; 429/304; 429/305; 429/310; 429/314; 429/231.950 (keyword delimited) Electronic data base consulted during the international search (name of data base and, where practicable, search terms used) Orbit, Google Patents, Google Scholar Search terms used: air, battery, electrode, ionically, conducting, polymer, oxygen, gas, load, solid, reduce, thermoplastic, crystallinity, melt, glossy, cationic, anionic, diffusing, charge transfer complex, monomers, backbone, ring, conductivity, diffusivity, transference, heteroatom, sulfur, non-flammable, young's, electron acceptor, conjugated, test, rest, pyrolusite, AA		
<b>C. DOCUMENTS CONSIDERED TO BE RELEVANT</b>		
Category*	Citation of document, with indication, where appropriate, of the relevant passages	Relevant to claim No.
X	US 2014/0227614 A1 (KOREA UNIVERSITY RESEARCH AND BUSINESS FOUNDATION et al) 14 August 2014 (14.08.2014) entire document	1, 13, 14, 22, 25, 47-49, 57-69, 75-79
---		---
Y		2-12, 15-21, 23, 24, 26-46, 50-56, 70-74, 80-95
Y	US 6,461,724 B1 (RADOVANOVIC et al) 08 October 2002 (08.10.2002) entire document	2-4, 7-9, 11, 16-19, 21, 23, 26-28, 30-37, 50
Y	US 2005/0287441 A1 (PASSERINI et al) 29 December 2005 (29.12.2005) entire document	2-4, 9, 11, 15-19, 21, 23, 26-28, 30-37, 50
Y	US 3,336,279 A (SCOTT) 15 August 1967 (15.08.1967) entire document	3, 4, 6-11, 20
Y	US 2009/0162755 A1 (NEUDECKER) 25 June 2009 (25.06.2009) entire document	5-11, 20
Y	US 2014/0141336 A1 (MORIN) 22 May 2014 (22.05.2014) entire document	12
Y	US 2012/0107690 A1 (WAKIZAKA et al) 03 May 2012 (03.05.2012) entire document	17, 18
Y	US 2015/0064575 A1 (HE et al) 05 March 2015 (05.03.2015) entire document	24, 34, 51
Y	US 2012/0115049 A1 (RINZLER et al) 10 May 2012 (10.05.2012) entire document	29, 30, 50
Y	US 2011/0204341 A1 (BROWN et al) 25 August 2011 (25.08.2011) entire document	38-42, 44
<input checked="" type="checkbox"/> Further documents are listed in the continuation of Box C. <input type="checkbox"/> See patent family annex.		
* Special categories of cited documents: "A" document defining the general state of the art which is not considered to be of particular relevance "E" earlier application or patent but published on or after the international filing date "L" document which may throw doubts on priority claim(s) or which is cited to establish the publication date of another citation or other special reason (as specified) "O" document referring to an oral disclosure, use, exhibition or other means "P" document published prior to the international filing date but later than the priority date claimed "T" later document published after the international filing date or priority date and not in conflict with the application but cited to understand the principle or theory underlying the invention "X" document of particular relevance; the claimed invention cannot be considered novel or cannot be considered to involve an inventive step when the document is taken alone "Y" document of particular relevance; the claimed invention cannot be considered to involve an inventive step when the document is combined with one or more other such documents, such combination being obvious to a person skilled in the art "&" document member of the same patent family		
Date of the actual completion of the international search 30 September 2016		Date of mailing of the international search report <b>26 OCT 2016</b>
Name and mailing address of the ISA/ Mail Stop PCT, Attn: ISA/US, Commissioner for Patents P.O. Box 1450, Alexandria, VA 22313-1450 Facsimile No. 571-273-8300		Authorized officer Blaine R. Copenheaver PCT Helpdesk: 571-272-4300 PCT OSP: 571-272-7774

## INTERNATIONAL SEARCH REPORT

International application No.

PCT/US2016/035040

C (Continuation). DOCUMENTS CONSIDERED TO BE RELEVANT		
Category*	Citation of document, with indication, where appropriate, of the relevant passages	Relevant to claim No.
Y	US 5,424,151 A (KOKSBANG et al) 13 June 1995 (13.06.1995) entire document	43
Y	US 2013/0189589 A1 (HASHAIKEH et al) 25 July 2013 (25.07.2013) entire document	45, 52
Y	US 4,465,744 A (SUSMAN et al) 14 August 1984 (14.08.1984) entire document	46
Y	US 2013/0216936 A1 (FUCHS et al) 22 August 2013 (22.08.2013) entire document	53-56
Y	US 2012/0094250 A1 (LLOYD et al) 19 April 2012 (19.04.2012) entire document	70-74
Y	US 2004/0076881 A1 (BOWDEN et al) 22 April 2004 (22.04.2004) entire document	80-94
Y	US 5,160,880 A (PALANISAMY) 03 November 1992 (03.11.1992) entire document	87-94
Y	US 6,074,773 A (WILKINSON et al) 13 June 2000 (13.06.2000) entire document	95
A	US 2008/0199755 A1 (BROTHERSTON et al) 21 August 2008 (21.08.2008) entire document	1-95

## INTERNATIONAL SEARCH REPORT

International application No.

PCT/US2016/035040

**Box No. II Observations where certain claims were found unsearchable (Continuation of item 2 of first sheet)**

This international search report has not been established in respect of certain claims under Article 17(2)(a) for the following reasons:

1.  Claims Nos.:  
because they relate to subject matter not required to be searched by this Authority, namely:
  
2.  Claims Nos.:  
because they relate to parts of the international application that do not comply with the prescribed requirements to such an extent that no meaningful international search can be carried out, specifically:
  
3.  Claims Nos.:  
because they are dependent claims and are not drafted in accordance with the second and third sentences of Rule 6.4(a).

**Box No. III Observations where unity of invention is lacking (Continuation of item 3 of first sheet)**

This International Searching Authority found multiple inventions in this international application, as follows:

See supplemental page

1.  As all required additional search fees were timely paid by the applicant, this international search report covers all searchable claims.
2.  As all searchable claims could be searched without effort justifying additional fees, this Authority did not invite payment of additional fees.
3.  As only some of the required additional search fees were timely paid by the applicant, this international search report covers only those claims for which fees were paid, specifically claims Nos.:
  
4.  No required additional search fees were timely paid by the applicant. Consequently, this international search report is restricted to the invention first mentioned in the claims; it is covered by claims Nos.:  
1-95

**Remark on Protest**

- The additional search fees were accompanied by the applicant's protest and, where applicable, the payment of a protest fee.
- The additional search fees were accompanied by the applicant's protest but the applicable protest fee was not paid within the time limit specified in the invitation.
- No protest accompanied the payment of additional search fees.

## INTERNATIONAL SEARCH REPORT

International application No.

PCT/US2016/035040

Continued from Box No. III Observations where unity of invention is lacking

This application contains the following inventions or groups of inventions which are not so linked as to form a single general inventive concept under PCT Rule 13.1. In order for all inventions to be examined, the appropriate additional examination fees must be paid.

Group I, claims 1-95, drawn to a metal-air battery.

Group II, claims 96-120, drawn to a method of manufacturing an air electrode.

The inventions listed as Groups I-II do not relate to a single general inventive concept under PCT Rule 13.1 because, under PCT Rule 13.2, they lack the same or corresponding special technical features for the following reasons: the special technical feature of the Group I invention: a negative electrode comprising a first electrochemically active metal; and an ionically conducting, dielectric nonelectrochemically active material interposed between the air electrode and the negative electrode and in contact with the air electrode as claimed therein is not present in the invention of Group II. The special technical feature of the Group II invention: mixing a polymer with an ionic compound and an electron acceptor to create a first mixture; heating the first mixture to form the first mixture into a solid ionically conducting polymer material as claimed therein is not present in the invention of Group I.

Groups I and II lack unity of invention because even though the inventions of these groups require the technical feature of an electrically conductive material, and a solid ionically conducting polymer material, this technical feature is not a special technical feature as it does not make a contribution over the prior art.

Specifically, US 2008/0199755 A1 (BROTHERSTON et al) 21 August 2008 (21.08.2008) teaches an electrically conductive material (Paras. 60-62), and a solid ionically conducting polymer material (Paras. 8-10).

Since none of the special technical features of the Group I or II inventions are found in more than one of the inventions, unity of invention is lacking.